

# INSTALLATION INSTRUCTIONS

## CPL10 RF/IR COUPLER

The Model CPL10 extracts or injects IR control signals when used with TV coaxial RF cable systems, employing the patented Xtra Link™ principle.

### SPECIFICATIONS

- 2 - "F"-type threaded coaxial connectors
- 1 - IR signal I/O jack (3.5mm mono mini jack)
- Dimensions: 3" x 1-1/2" x 7/8"

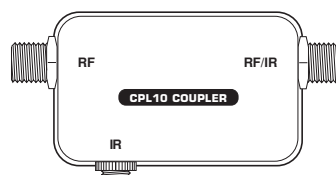

Fig. 1 Model CPL10 RF/IR Coupler

### INSTALLATION

Fig. 2 illustrates a simple installation using CPL10 Couplers in an IR repeater system. Control of a satellite receiver and a VCR from two remote rooms is accomplished over the same coaxial cable that carries the TV signal. When configuring this type of system, keep the following items in mind:

1. CPL10's may be used for both injecting and extracting the IR signal on the coax at the IR receiver and equipment ends, as shown.
2. REMOTE ROOM 1 is an example of how any 3-lead Xantech IR receiver (or keypad) may be used in an Xtra Link type system. A CB12 Connecting Block makes the necessary connections between the three leads of the 480-00 "Dinky Link" IR Receiver, the 781RG Power Supply and the CPL10 Coupler.
3. REMOTE ROOM 2 shows the use of a 291-10 IR Receiver and an INJ94 Injector. Use the INJ94 instead of the CPL10 any time you use a Xantech IR receiver equipped with a quick connect stereo mini plug.

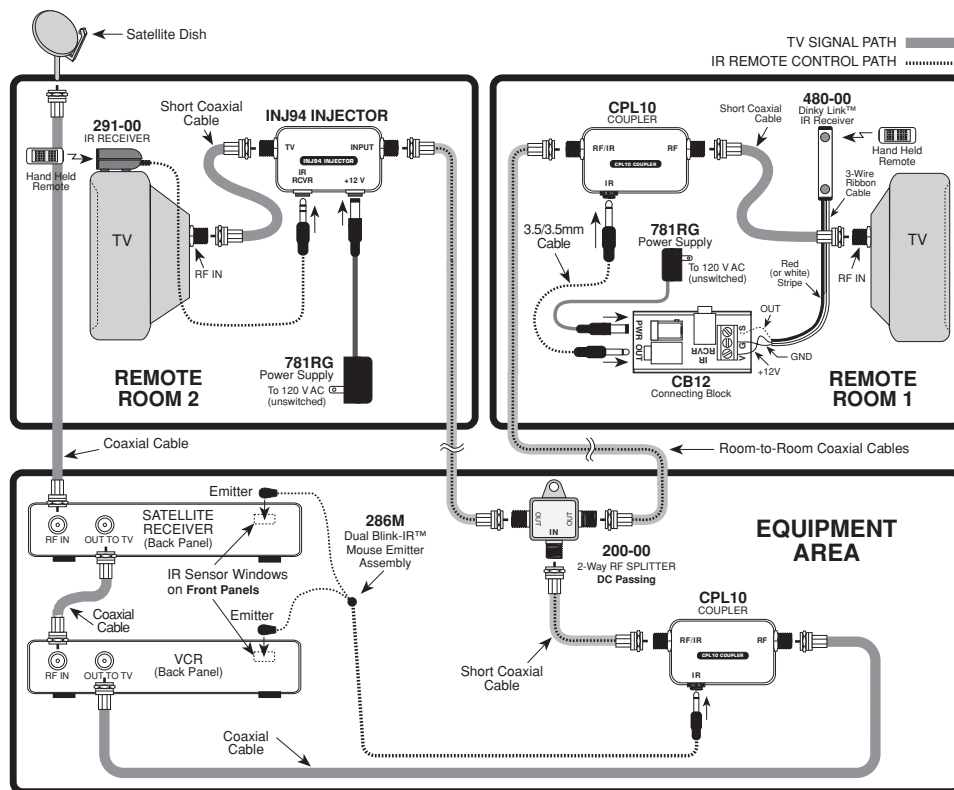

Fig. 2 Using CPL10's in a Basic System

- The 2-way RF splitter used in the equipment area must be a DC Passing type, such as the Xantech Model 200-00, as shown. This ensures that the IR coded pulses are passed through the RF splitter to the CPL10 to drive the 286-00 emitters.
- Be sure the CPL10 is placed between the source equipment (in this example a VCR) and the 2-way RF splitter as shown.
- Room-to-room coaxial cable lengths, exclusive of RF signal considerations, may be up to one mile in length, using RG-6, for successful IR signal transmission.

## ADVANCED MULTIROOM SYSTEMS

**Fig. 3** illustrates an advanced system using a variety of connection and control techniques typical of complex multiroom installations. It is configured as follows:

- Both CPL10 Couplers and INJ94 Injectors are used in the remote rooms with various Xantech IR Receivers.

As a rule of thumb, use the CPL10 with the CB12 Connecting Block when using Xantech 3-terminal IR receivers or keypads, such as the 480-00 Dinky Link, the Smart Pads, etc. Use the INJ94 when using Xantech IR receivers equipped with a 3.5mm quick-connect stereo mini plug, such as the 291-10 Hidden Link, the 490-30 Micro Link, 480-30 Dinky Link, etc.

- When configuring multiple rooms, be sure the RF splitters used are DC passing types, such as Xantech Models 200-00 (2-way) and 202-00 (4-way). Refer to **Figs. 2** and **3**.
- Each IR receiver must be locally powered by a 781RG Power Supply as shown.
- Note that model 203-00 DC Blockers are used on the two coax leads going to the two TV sets in the rooms *not* having IR receivers. This is a **must** to prevent the RF inputs on the two TV sets from "shorting out" the IR control signal.

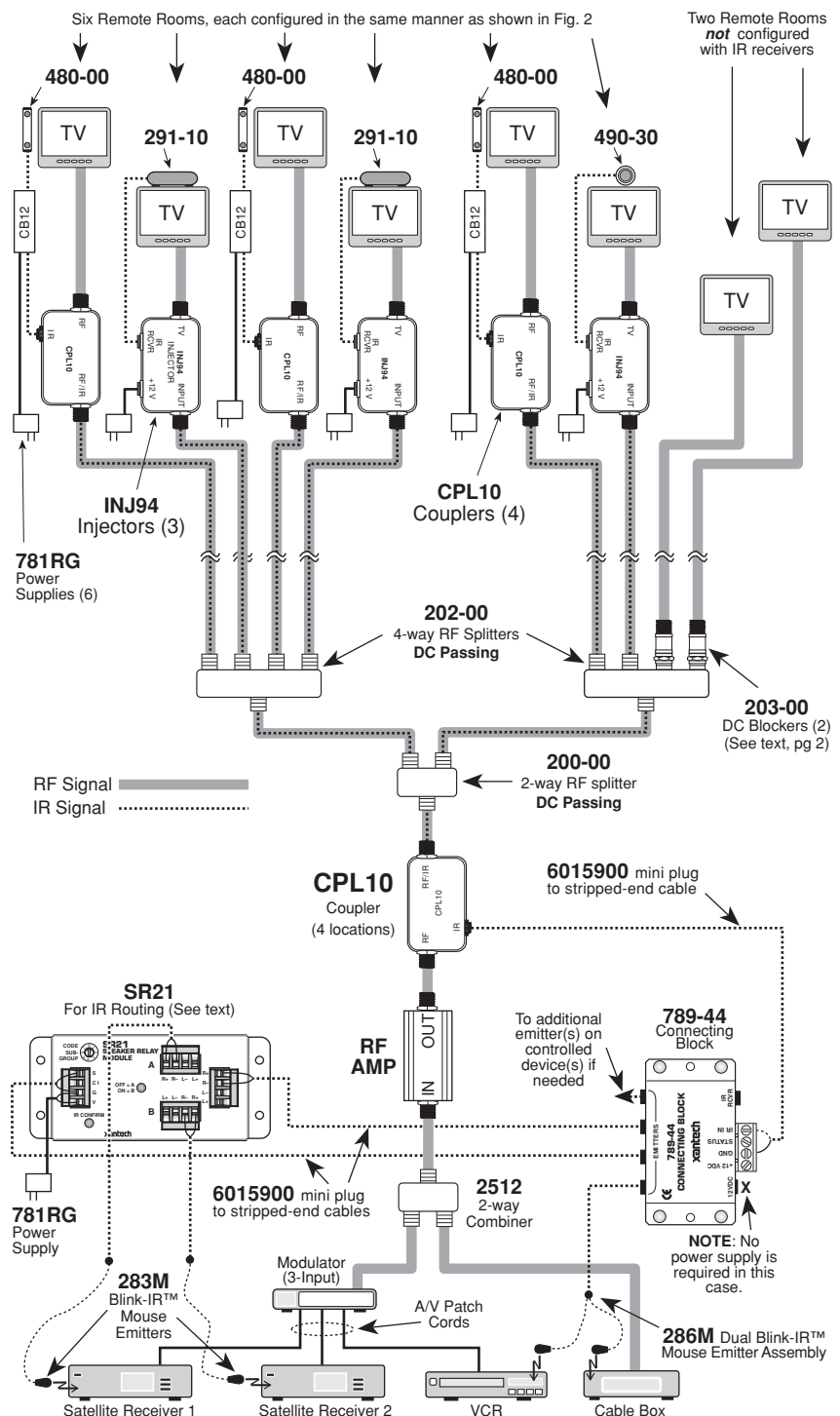

**Fig. 3** Using CPL10's in an Advanced System

5. If an RF amplifier(s) is used anywhere in the line of coaxial cable between the CPL10 Coupler and the INJ94 Injectors (or the CPL10's used as Injectors), you **must** use a Xantech BYPASS94 Kit to route the IR control signals around the amplifier(s) as shown in **Fig. 4**.
6. Where possible, place RF amplifiers ahead of the CPL10 Coupler, as shown in **Fig. 3**, instead of using a bypass kit.
7. To drive the necessary emitters and devices, a 789-44 Connecting Block is connected to the IR jack on the CPL10 to make four emitter jacks available.

**NOTE: NO POWER SUPPLY IS NECESSARY ON THE 789-44 WHEN IT IS USED ONLY AS AN EMITTER EXPANSION BLOCK, AS IN THIS CASE.**

8. **Fig. 3** also shows a Xantech SR21 Speaker Relay Module used as an IR Router so that control of two satellite receivers (or other products having identical IR control codes) can be addressed individually from any remote room location. (Refer to the SR21 Installation Instructions for information on using it for IR routing).

In this type of operation, you may program a learning device, such as the Xantech URC-1 Universal Learning Remote Control or the Smart Pads, with sequence commands (macros). These sequences would issue channel commands to the remote room TV's to switch them to the modulator channel for the desired satellite receiver along with the corresponding IR router command for the SR21 -- all with one button press. You would then program other buttons with the satellite receiver commands.

To program sequences, refer to instructions for the learning device.

9. For information on how to connect and configure modulators and RF amplifiers, refer to Channel Plus® technical information.

## TROUBLE SHOOTING

1. Perhaps the most common problem encountered is stray IR or RF interference preventing proper operation of the controlled equipment.

Examples of such interference are:

- Fluorescent, Compact Fluorescent, Neon or Halogen lights, Neon Art, and light dimmers.
- Direct or reflected sunlight.
- Infrared security sensors (active type).
- RF radiation from TV sets that may be close to IR Receivers.

It may be necessary to move either the interfering source or the IR receiver to achieve proper operation. Sometimes the Xantech Sun Filters will help.

2. Check for shorts or opens anywhere between the IR receivers in the remote rooms and the emitters at the controlled equipment.
  - Remember, you must have DC continuity all the way from the IR (IR RCVR) jacks on the Injectors, through the coax cables to the IR (emitter) jack on the coupler, without shorts to ground.
  - Use a Xantech 179-99 Test-IR plugged into the IR (emitter) jack on the coupler to verify that the IR signal is being received from each room.
  - If necessary, use a multimeter in the low Ohms range to check for continuity, shorts, opens, etc.
  - Check for open emitters by substituting a known good emitter.
3. If a given component does not work, reposition the emitter. It may not be located directly over the component's IR (infrared) sensor receiving "window". Consult the owner's manual of the unit or the manufacturer for the exact location of the IR "window".

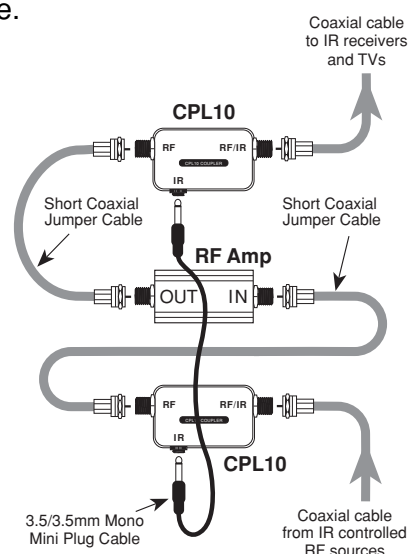

**Fig. 4** Using a Xantech BYPASS94 Kit