

# INSTRUCTION MANUAL

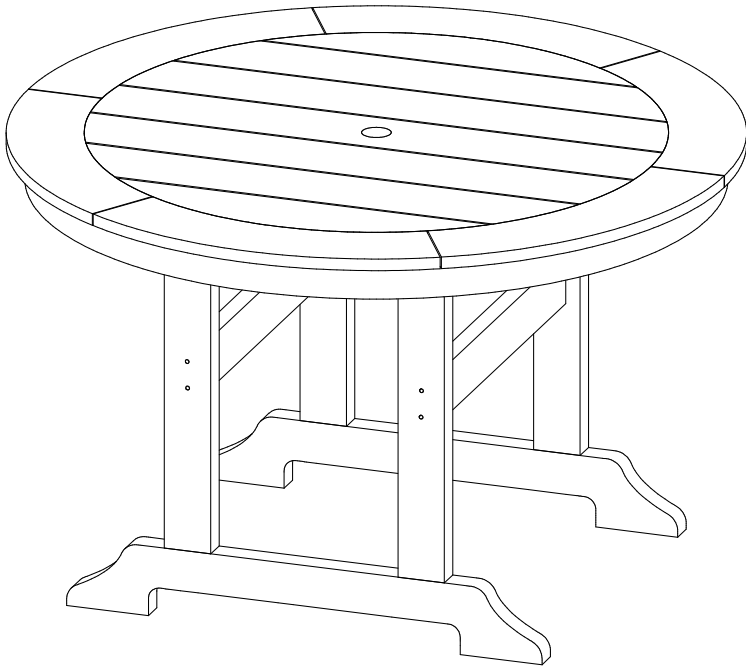

**Laguna 47" Round Dining Table**  
**SKU:OP8004**

**V1.0**

## ! NOTICE

### Do not overtighten screws. (Insert all screws before tighten screws.)

- Please do not exceed the weight limitations of this item.
- Do not stand on or use any part of this item as a step ladder.
- Firmly secure all bolts, screws and nuts before use.
- Reconfirm that all bolts, screws, and nuts are secure every 90 days.
- Do not use or store this item in the proximity of open flame or flammable/combustible chemicals.
- Be aware that some parts are heavy and have sharp edges.
- Please adjust the speed slowly when you use electric drill for assembling to avoid screw slippage.

## TOOLS REQUIRED

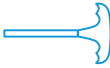

ALLEN WRENCH  
(PROVIDED)



WRENCH  
(PROVIDED)



TABLE  
330 LBS  
CAPACITY



1 PERSON  
ASSEMBLY



UP TO 20 MIN.  
ASSEMBLY

## HARDWARE

1

M6.3 x80mm  
BOLT

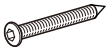

8 PCS

2

M6 x100mm  
BOLT



8 PCS

3

M6 x65mm  
BOLT



8 PCS

4

M6 NUT



8 PCS

5

M6 WASHER



8 PCS

6

ALLEN  
WRENCH



1 PC

7

WRENCH

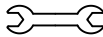

1 PC

8

SCREWDRIVER  
BLADES



1 PC

## PARTS

A

TABLE TOP

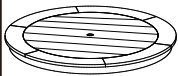

1 PC

B

TABLE BOTTOM  
FEET



2 PCS

C

TABLE LEG

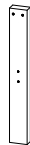

4 PCS

D

SIDE RAIL



2 PCS

E

UMBRELLA  
HOLE COVER



1 PC

## PRODUCT ASSEMBLY-OVERALL VIEW

1

Look at following overall view of this table and exact position of each parts to be assembled

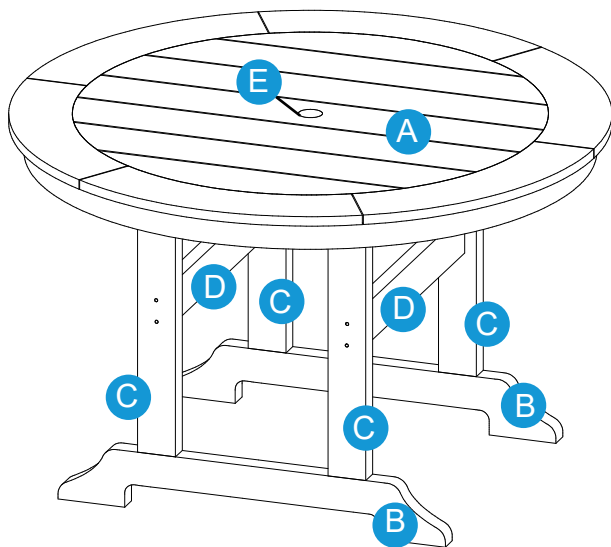

## PRODUCT ASSEMBLY

1

Attach part B Table Bottom Feet to part C Table Leg with 8 pcs of Hardware 1 Bolt.

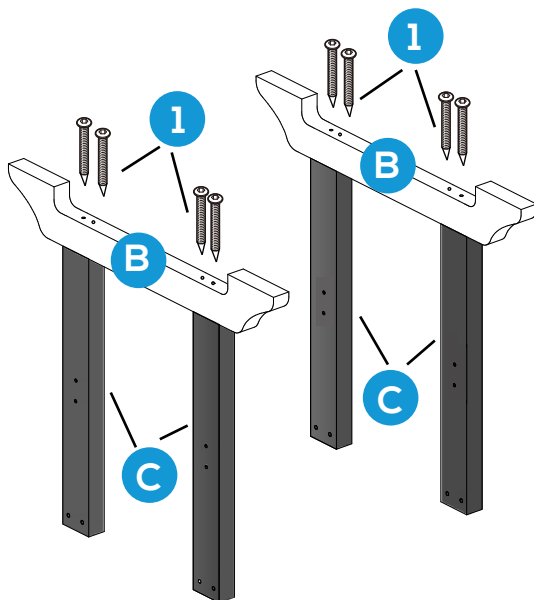

## PRODUCT ASSEMBLY

2

Attach part C Table Leg to part A Table Top with 8 pcs of Hardware 2 Bolt, 4 Nut and 5 Washer

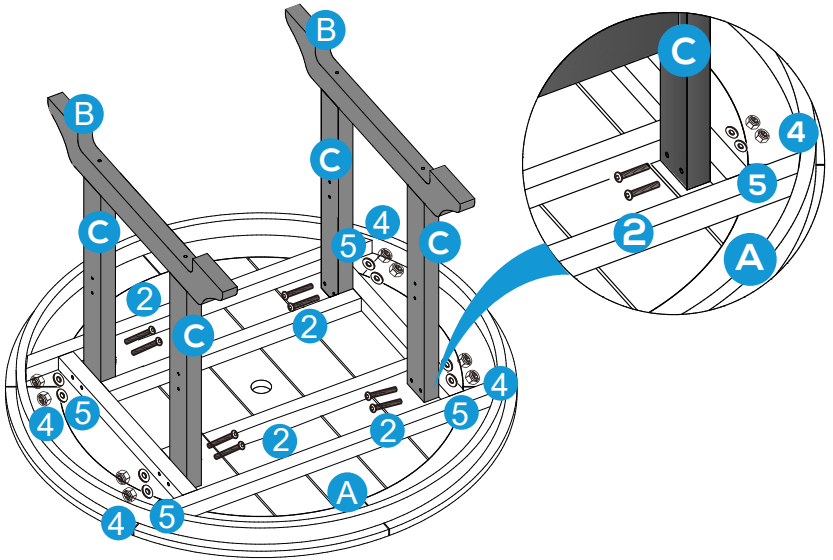

3

Attach part D Side Rail to part C Table Leg with 8 pcs of Hardware 3 Bolt.

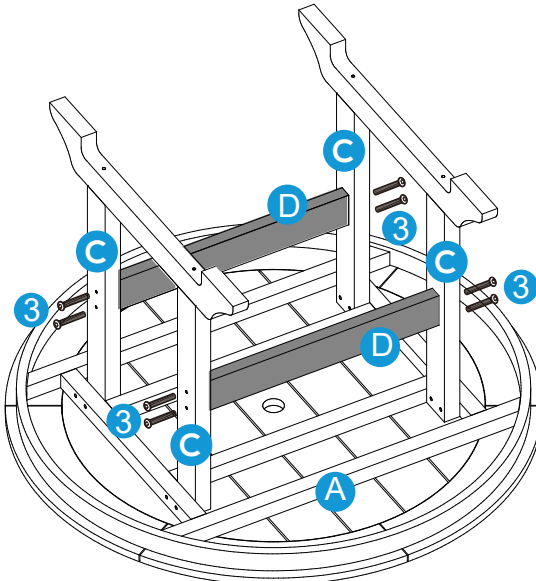

Check and tighten all the bolts and screws again and finish the assembly.

Remark: Please remove the umbrella hole cover when you insert the umbrella!

