

FALMGREN[®]
a CH Hanson brand



25 Ton Manual Hydraulic Press

Model 9661613



**PLEASE READ AND SAVE
THESE INSTRUCTIONS.
READ CAREFULLY
BEFORE ATTEMPTING
TO ASSEMBLE, INSTALL,
OPERATE OR MAINTAIN THE
PRODUCT DESCRIBED.**

**PROTECT YOURSELF AND
OTHERS BY OBSERVING ALL
SAFETY INFORMATION. FAILURE
TO COMPLY WITH INSTRUCTIONS
COULD RESULT IN PERSONAL
INJURY AND/OR PROPERTY
DAMAGE! RETAIN INSTRUCTIONS
FOR FUTURE REFERENCE.**

**PLEASE REFER TO BACK COVER
FOR INFORMATION REGARDING
PALMGREN'S WARRANTY
AND OTHER IMPORTANT
INFORMATION.**

Model #: _____

Serial #: _____

Purch. Date: _____

GETTING STARTED

Save this manual

You will need this manual for the safety warnings and precautions, assembly instructions, operating and maintenance procedures, parts lists and diagrams. Keep your invoice with this manual. Write the invoice number on the inside of the front cover. Keep this manual and invoice in a safe and dry place for future reference.

Structural requirements



Make sure all supporting structures and load attaching devices are strong enough to hold your intended loads. If in doubt, consult a qualified structural engineer.

Electrical requirements

Not applicable for manual presses.

Tools needed

Standard professional mechanic's hand tool set (i.e. hammer, screwdrivers, wrenches, socket wrenches, pliers, etc.).

UNPACKING

When unpacking, check to make sure all parts listed below are included. If any parts are missing or broken, please contact your local retailer.

IMPORTANT: Many unpainted steel surfaces have been coated with a protectant. To ensure proper fit and operation, remove the coating. Coating can be easily removed with mild solvents, such as mineral spirits, and a soft cloth. Avoid getting solution on paint or any of the rubber/plastic parts. Solvents may deteriorate these finishes. Use soap and water on paint, plastic or rubber components. After cleaning, cover all exposed surfaces with a light coating of oil.

CAUTION *Never use highly volatile solvents. Avoid getting cleaning solution on paint as it may tend to deteriorate these finishes. Use soap and water on painted components.*

Contents:

Pipe holder	2
Hydraulic pump assembly	1
Frame with cylinder	1
Bag of replacement rubber o-rings and hardware	1
Manual	1

Unpack



Remove all the over packing materials, but leave unit attached to its pallet. Do not discard packing materials until after the machine has been inspected for damage and completeness. Locate loose parts and set aside.

Inspect



- After unpacking the unit, carefully inspect for any damage that may have occurred during transit. Check for loose, missing or damaged parts. Shipping damage claims must be filed with the carrier.

All tools should be visually inspected before use, in addition to regular periodic maintenance inspections.

SAFETY RULES

▲ WARNING *Completely read and understand this owner's manual before assembly or tool operation. Read and understand the warnings shown on the machine and in this manual. Failure to comply with all of these warnings may cause serious injury or death.*



PROPOSITION 65 WARNING: *Some dust created by using power tools contain chemicals known to the state of California to cause cancer, birth defects or other reproductive harm.*

Some Examples of these chemicals are:

- Lead from lead-based paints
- Crystalline silica from bricks and cement and other masonry products.
- Arsenic and chromium from chemically-treated lumber.

Your risk from these exposures varies, depending on how often you do this type of work. To reduce your exposure to these chemicals: work in a well ventilated area and work with approved safety equipment. Always wear an OSHA/NIOSH approved, properly fitting face mask or respirator when using such tools.

▲ WARNING *Always follow proper operating procedures as defined in this manual even if you are familiar with the use of this or similar tools. Remember that being careless for even a fraction of a second can result in severe personal injury.*

Preparing for your job

- Wear proper apparel. Do not wear loose clothing, neckties, rings, bracelets or other jewelry which may get caught up in moving parts of machine. Do NOT wear gloves.
- Wear protective hair covering to contain long hair.
- Wear safety shoes with non-slip soles.
- Wear safety glasses complying with United States ANSI Z87.1. Everyday glasses have only impact resistant lenses. They are not safety glasses. Use guards and eye shields.
- Wear face mask or dust mask if operation is dusty.
- Wear ANSI approved ear protection for extended operation.
- Some coolants used for machining contain chemicals that may be hazardous to your health if not used properly. Read and understand all information on the coolant container and protect yourself accordingly.
- Be alert and think clearly. Never operate power tools when tired, intoxicated or when taking medications that cause drowsiness.
- Focus your attention completely on your work. Looking around, careless actions and other distractions can result in serious injury.

Preparing the work area for your job

- Do not use this machine in dangerous environments. Do not use it in damp or wet locations. Do not expose it to rain.
- Keep the work area clean. Cluttered work areas and work benches invite accidents. Keep the area around the machine clean of scrap metal, oil and grease.

- Keep visitors at a safe distance from work area.
- Keep children out of workplace. Make workshop childproof. Use padlocks, master switches or remove switch keys to prevent any unintentional use of power tools.
- Provide adequate space around the hydraulic press and light the area properly with non-glare, overhead lighting.
- Make certain the hydraulic press is securely anchored before use.

Maintaining your tool

- Failure to follow the guidelines in this manual can result in serious injury.
- Consult this manual for the proper use, specific maintenance, and adjustment procedures.
- Keep tool lubricated and clean for safest operation.
- Read and understand warnings posted on the machine and in this manual. Replace the warning labels if they become obscured or removed. Failure to comply with all of these warnings can result in serious injury.
- Before using the machine, check for damaged parts. Check for alignment of moving parts, binding, breakage, mounting issues and any other conditions that may affect the tools operation. Replace any guard or damaged part that does not function properly before using the tool.
- Use compressed air or a suitable brush to clear chips or debris — do not use your hands.

Know how to use your tool

▲ WARNING *The operation of any tool can result in foreign objects being thrown into the eyes, which can result in severe eye damage. Always wear safety goggles complying with United States ANSI Z87.1. before commencing power tool operation.*



Think safety! Safety is a combination of operator common sense and alertness at all times when tool is being used.

- The Model 9661613 Hydraulic Press is designed and intended for use by properly trained operators. You must be familiar with the proper and safe operation of a manual hydraulic press. Obtain proper training and knowledge before operating this machine.
- Do not use the Model 9661613 Hydraulic Press for any use other than its intended application. Improper use of this tool revokes and voids any real or implied warranty. The manufacturer is not responsible for any injury that may result from improper use of the machine.
- Do not force an attachment to do a job it was not intended or designed for.
- Never stand on the machine or work in an awkward position. Maintain your balance. Never lean against the machine, over reach or use excessive force when working. You could tip or fall into the machine causing serious injury.
- Know your tool. Learn the tool's operation, application and specific limitations. Never force the machine to do a task it was not designed for.

- Use recommended accessories. Understand and obey all safety instructions supplied with accessories. The use of improper accessories may cause risk of injury to persons.
- Always use guards and eyeshields.

SPECIFICATIONS

Model 9661613 25 Ton Manual Hydraulic Press

Parameter	9661613
Capacity (tons)	25
Stroke travel (inch)	9.5
Ram diameter (inch)	1.5 or 2.25
Table Size (inch)	12x10.5
Max distance ram to table (inch)	27
Head movement	No
Dimension (inch)	35x14x62
Weight (lbs)	441
Working Temperature Range (°F)	50 - 122

ASSEMBLY/INSTALLATION

Lifting and setting up your machine

▲ WARNING *Make certain that slings, cables, chains, forklifts or other load suspending gear or machines used to move this unit are properly rated to handle the weight. The machine is extremely heavy.*

▲ CAUTION *The machine must be properly secured and anchored before use. Make sure that it is supported equally on all four corners. Failure to comply may result in the machine twisting and causing binds in the working table.*

1. Two pairs of bolts, nuts, and washers are installed on the side of the frame. Remove the washers and nuts leaving the bolts in the frame.
2. Unwrap the hydraulic station from packaging. The hose should already be attached to the hydraulic cylinder. If not, reattach it.
3. Position the hydraulic station as shown in the following figure and match the two holes in the mounting frames of the hydraulic station with the hanging bolts. One hole should be near the top, and the other near bottom of the station.



4. Slide the washers back on, and tighten the nuts on the mounting frame of the hydraulic station to secure the station.
5. Insert the handle into either of receivers as shown below. This can be changed at any time, since the bar is not secured.



Machine dimensions

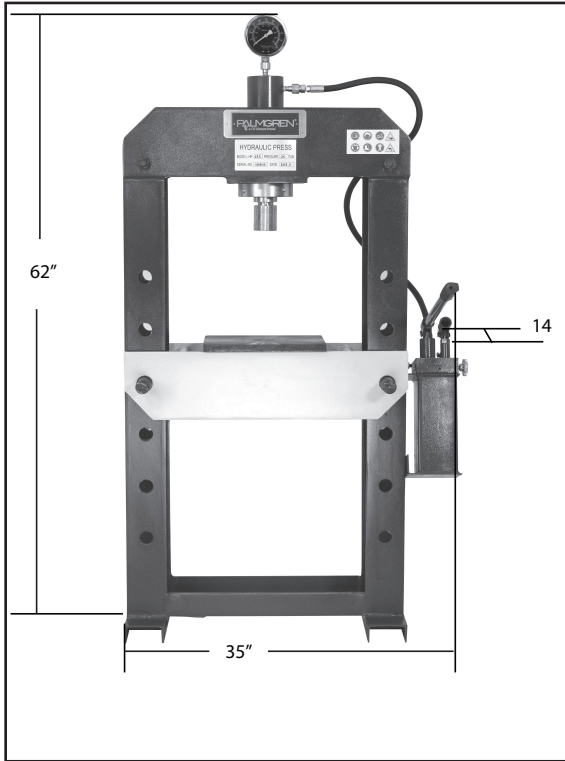

Lubrication

CAUTION Do not operate this machine before lubrication and ensuring proper oil level. Failure to comply may damage the machine.

Fill the pump with 32# or 46# hydraulic oil as shown by the fill indications.

OPERATION

WARNING Always wear safety glasses complying with U.S. ANSI Z87.1 before beginning any power tool operation.

CAUTION Do not operate this machine before properly lubricating the machine. Failure to lubricate the machine before using can cause damage to the machine.

Using the press

WARNING If the press exceeds the maximum temperature (see "SPECIFICATIONS"), wait to use until cool.

WARNING Pieces to be pressed must have a compact, solid structure and must not be subject to crumbling or other structural damage potential.

1. When setting up the piece to be pressed, ensure that it is centered with respect to the piston.
2. Place the handle in the appropriate pump cylinder as shown in the following figure.

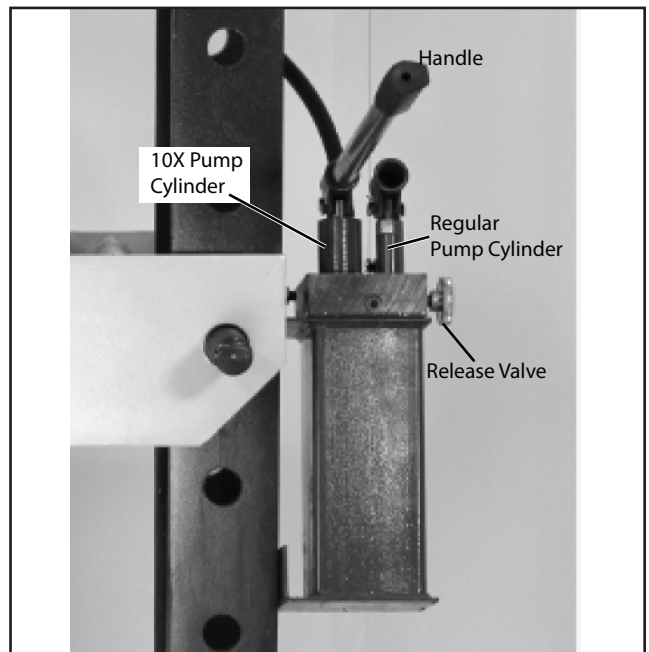

3. Pump the hydraulic station.
4. Check the pressure using the pressure gauge on top of the unit, shown below.

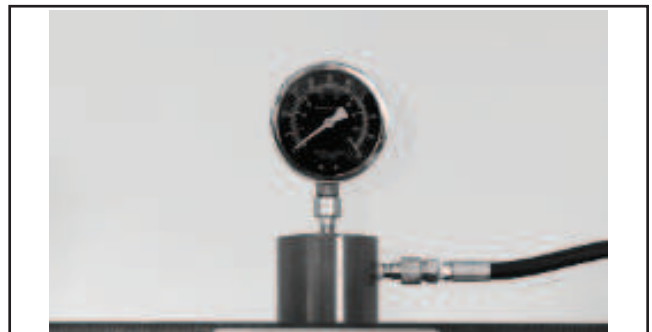

5. To release pressure, turn release valve counter-clockwise. This also returns the plunger to its initial position.

Table Height Adjustment

1. Unload the table of all extra items.
2. Lift the table support beam on one side. We recommend asking for assistance in holding the beam, although it is possible to do so only by oneself.
3. Extract the support pin as shown in



4. Insert the pin into the next adjacent hole, either above or below the original hole. Make sure to insert the pin all the way through both the front and back of the Hydraulic press frame.
5. Then ease the support beam back onto the pin. When done this way, only one person is required.
6. Repeat all previous steps for the opposite side.
7. Repeat until the desired height is achieved.

TROUBLESHOOTING GUIDE

Symptom	Possible Cause(s)	Corrective Action
Ram does not move	Low oil condition	Fill oil
Ram does not press	Cylinder valve not closed	Close cylinder valve

GETTING STARTED

SAFETY / SPECIFICATIONS

ASSEMBLY / INSTALLATION

OPERATION

TROUBLESHOOTING

MAINTENANCE / REPAIR

MAINTENANCE/REPAIR

▲ WARNING Before any maintenance is performed, ensure all pressure has been released, using the release valve on the side of the hydraulic station.

Daily:

- General visual inspection-check for any visible damage or missing parts
- Check that all labels are clearly visible and legible
- Check for hydraulic fluid leaks

Weekly:

- Check oil level
- General cleaning

Monthly:

- Check wear on the hydraulic piston and station
- Check tightness of the bolts

Half Year

- Refill with #32 or #46 Hydraulic oil every 6 months. After refilling, have the piston move up and down to remove the air from the inside the cylinder.

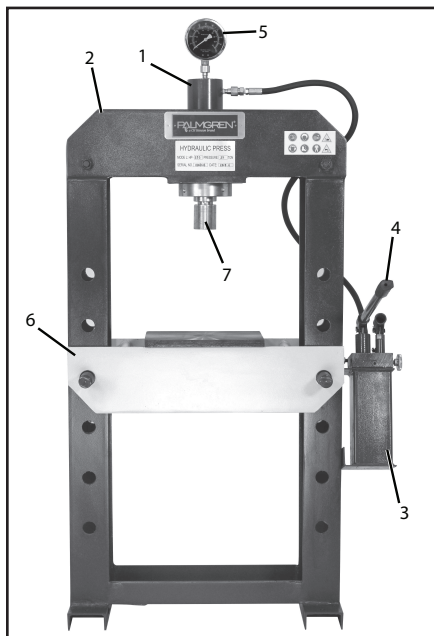

Item No.	Description	Part No.	Qty
1	Cylinder	9643611.01	1
2	Framework	NA	1
3	Hydraulic Station	9643612.01	1
4	Hydraulic Station Handle	9643613.01	1
5	Hydraulic Gauge	9643614.01	1
6	Table Frame	NA	1
7	Ram	964615.01	1

MAINTENANCE/REPAIR

Hydraulic Cylinder Parts

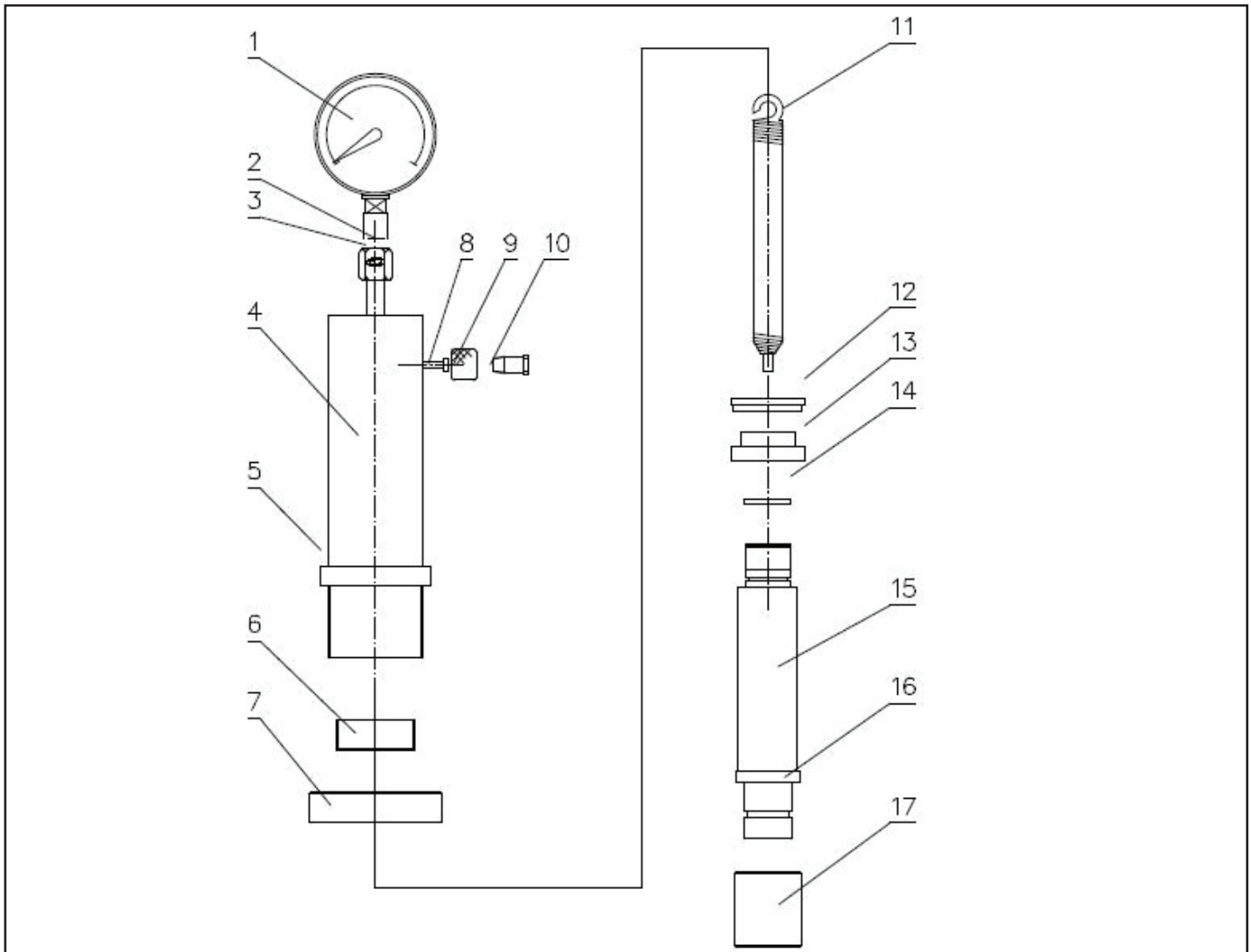

Item No.	Description	Qty	Item No.	Description	Qty
1	Press Gauge	1	10	Coupling	1
2	Nylon Seal	1	11	Spring	1
3	Coupling Bolt	1	12	Y-Ring	1
4	Oil Cylinder	1	13	Piston Head	1
5	Small Screw	1	14	O-Ring	1
6	Retainer	1	15	Piston Rod	1
7	Big Screw	1	16	Protecting Cap	1
8	Hex Nut	1	17	Cap	1
9	Screw	1			

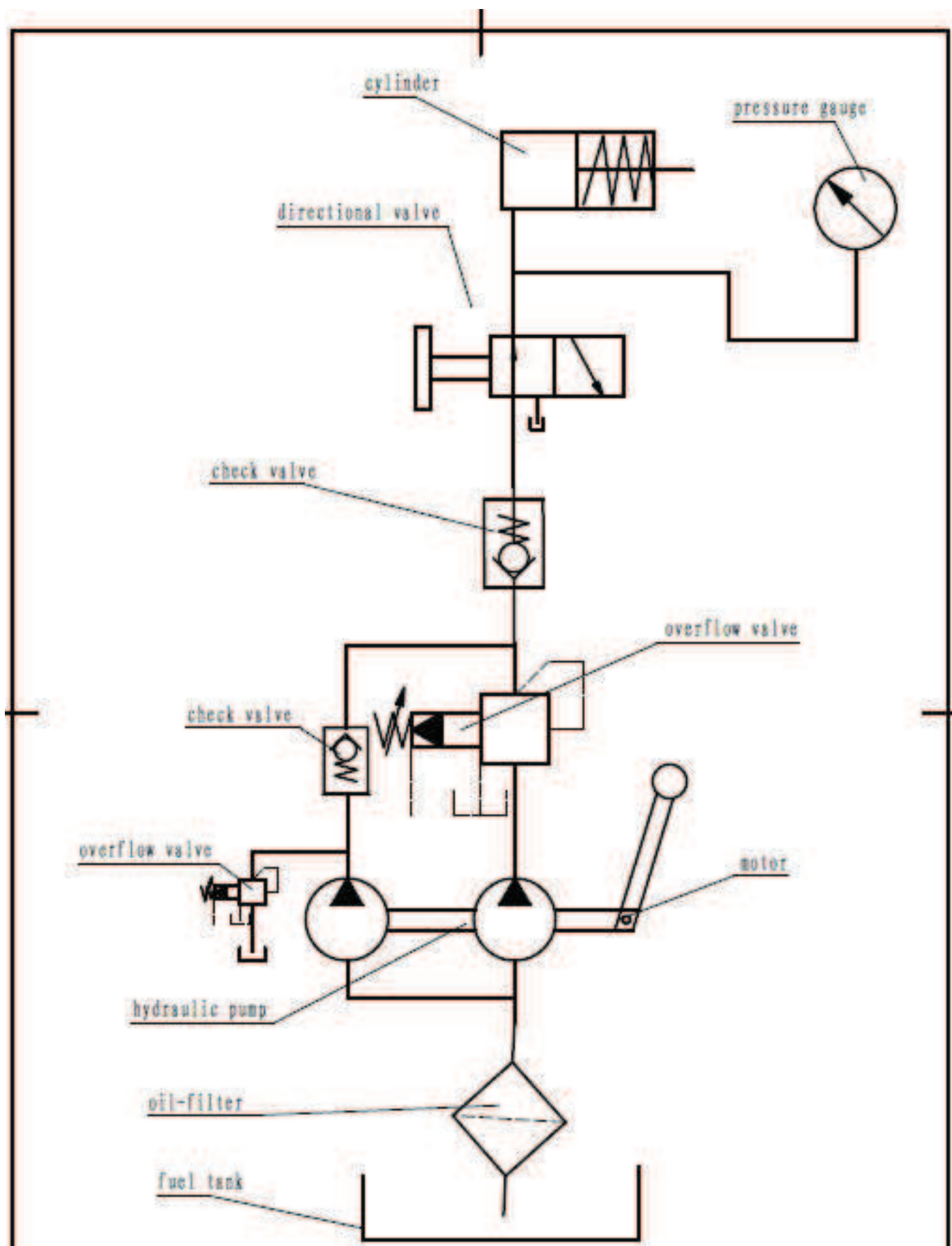

PALMGREN WARRANTY

C.H. Hanson / Palmgren warrants their products to be free of defects in material or workmanship. This warranty does not cover defects due directly or indirectly to misuse, abuse, normal wear and tear, failure to properly maintain the product, heated, ground or otherwise altered, or used for a purpose other than that for which is was intended.

The warranty does not cover expendable and/or wear part (i.e. v-belts, screws, abrasives, jaws), damage to tools arising from alteration, abuse or use other than their intended purpose, packing and freight. The duration of this warranty is expressly limited to the terms noted below beginning from the date of delivery to the original user.

The Palmgren branded items carry the following warranties on parts:

All vises, clamps, positioning tables, tombstones, jack screws and vise accessories - LIFETIME.

All bench grinders, drill presses, tapping machines, band saws, lathes, milling machines, arbor presses, abrasive finishing machines and work stands - 3 YEARS.

The obligation of C.H. Hanson / Palmgren is limited solely to the repair or replacement, at our option, at its factory or authorized repair agent of any part that should prove inoperable. Purchaser must lubricate and maintain the product under normal operating conditions at all times. Prior to operation become familiar with product and the included materials, i.e. warnings, cautions and manuals.

Failure to follow these instructions will void the warranty.

This warranty is the purchaser's exclusive remedy against C.H. Hanson for any inoperable parts in its product. Under no circumstances is C.H. Hanson liable for any direct, indirect, incidental, special or consequential damages including loss of profits in any way elated to the use or inability to use our products. This warranty gives you specific legal rights which may vary from state to state.



Palmgren - a C.H. Hanson Company
2000 N. Aurora Rd., Naperville, IL 60563 U.S.A.
or call **1-800-827-3398**