



FLEXSTEEL®

W1447-034

## Round Cocktail Table

### IMPORTANT NOTE

Carefully remove all the parts from the carton and put them individually on a soft cloth to prevent damage to the parts.

We have taken great care in the design of this product and request that you carefully and strictly follow our assembly instructions to ensure a completed product as it was designed.

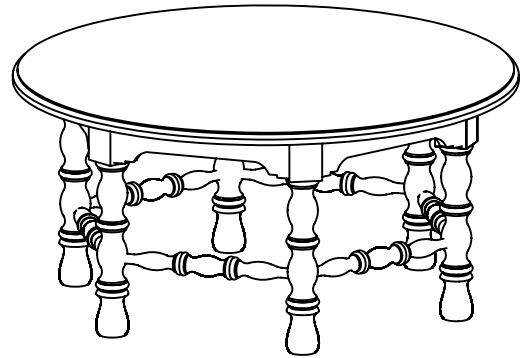

### Part List

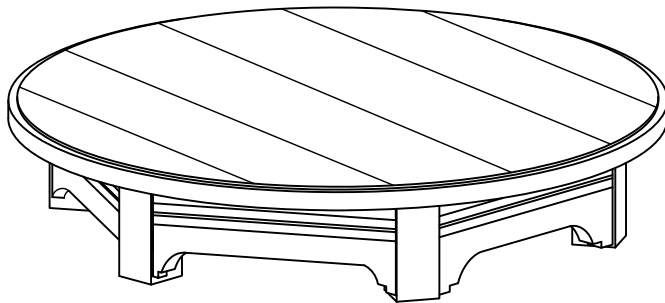

**A. Table Top Section**  
1 piece



**B. Leg**  
6 pieces



**C. Stretcher**  
6 pieces

### Hardware List

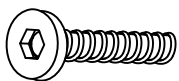

**Short Bolt**  
12 pieces



**Flat Washer**  
12 pieces



**Spring Washer**  
12 pieces



**Hex Key**  
1 piece



**Screw**  
12 pieces

Tool(s) recommended for assembly: Level and Screwdriver



### IMPORTANT

• Use a soft cloth between these parts and the floor.

### STEP 1

Place the Table Top section (A) upside-down on a soft surface. Attach the Legs (B), using Flat Washer, Spring Washer, hand start bolts 2-3 threads and leave legs loose. (See Figure 1).

**Warning:** It is extremely important, at this stage, to keep the bolts only loosely tightened in order to allow the legs to have some lateral movement for the next step on inserting and fixing the stretchers. Over tightening, of the bolts, allowing little, or no movement, could cause damage to the legs by needing the use of force to insert the stretchers.

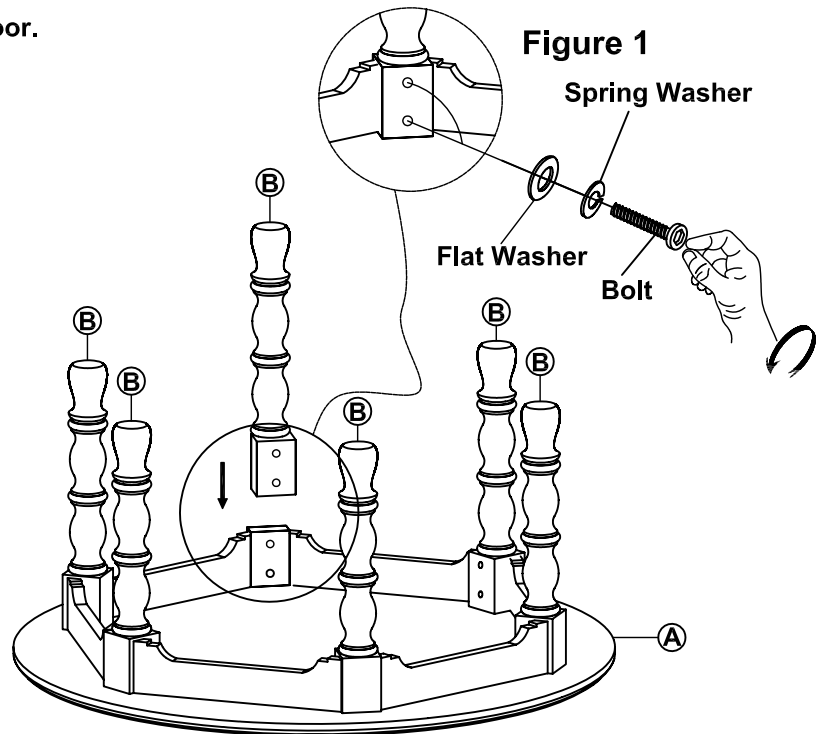

### STEP 2

Attach Stretcher (C) to the Legs (B), and fix securely with screws provided. (See Figure 2).

### STEP 3

Finally, after all stretchers are fixed in place, securely tighten all Bolts with Hex Key. (See Figure 3).

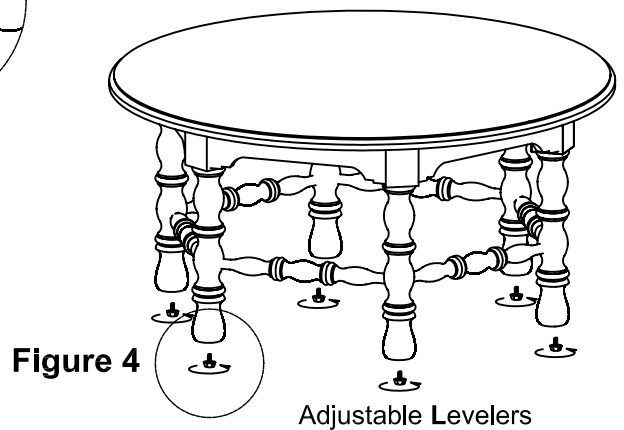
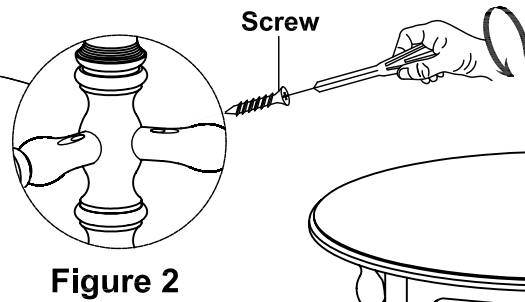
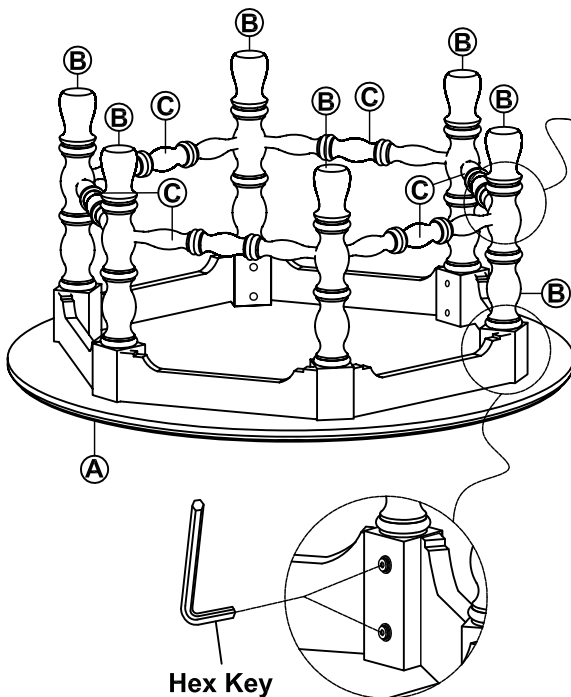

### STEP 4

Taking care not to put any undue pressure on the feet. Carefully place the table in an upright position. Adjust the levelers on the feet until the furniture is level. (See Figure 4.)

First time assembling or have further questions, we recommend you watch the video found by using this QR code

