

FLEXSTEEL®

W1077-826

Sideboard

IMPORTANT NOTE

Carefully remove all the parts from the carton and put them individually on a soft cloth to prevent damage to the parts.

We have taken great care in the design of this product and request that you carefully and strictly follow our assembly instructions to ensure a completed product as it was designed.

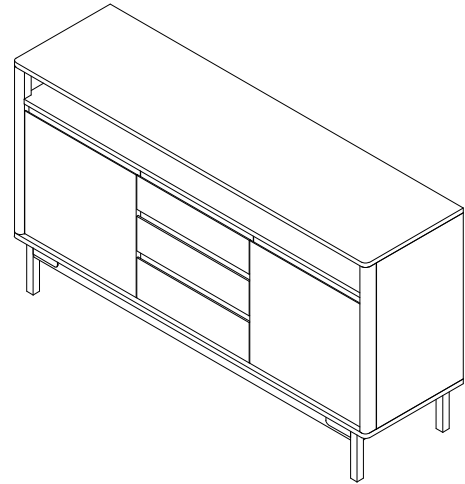

Part List

Assembly Instructions 1/5

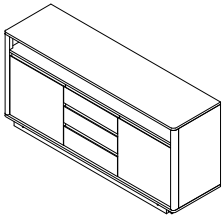

A. Sideboard
1 piece



B. Center Support Leg
1 piece

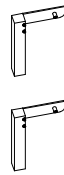

C. Right Legs
2 pieces

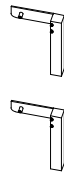

D. Left Legs
2 pieces

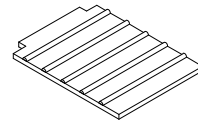

E. Left Shelf
2 pieces

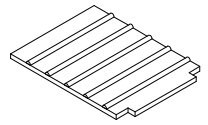

F. Right Shelf
1 piece

Hardware List



1.Flat Washer
 $\Phi 1/4 \times 19 \times 1.5\text{mm}$
12 pieces



2.Spring Washer
 $\Phi 1/4$ "
12 pieces



3.Long Bolt
 $\Phi 1/4$ " - 20 UNC*57mm
8 pieces



4.Short Bolt
 $\Phi 1/4$ " - 20 UNC*20mm
4 pieces

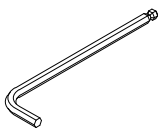

5.Hex Key
110*25*4mm
1 piece



6.Shelf Support
12 pieces

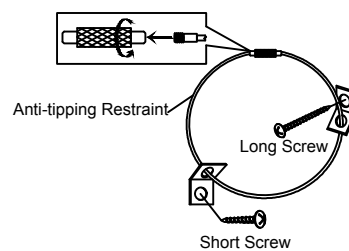

Anti-Tipping Device
1 set

Tool(s) recommended for assembly: Level and Screwdriver

IMPORTANT NOTES

- Do not tighten up all the bolts until each part is properly assembled.
- Keep the Hex Key in a safe place as you may need to tighten up the bolts in the future.
- Use a soft cloth between these parts and the floor.
- We recommend this product be assembled by at least two adults.

STEP 1

To assemble the Sideboard, attach Right Legs (C) and Left Legs (D) to Sideboard (A) with 2 Long Bolt (3), 1 Short Bolt (4), 3 Spring Washer (2) and 3 Flat Washer (1) for each leg. Repeat this step on each leg. (See Figure 1.)

IMPORTANT: Do not fully tighten all the bolts until all pieces are fitted together in the proper location.

Tighten Center Support Leg (B) to Sideboard (A) by rotate the leg to the right. (See Figure 1.)

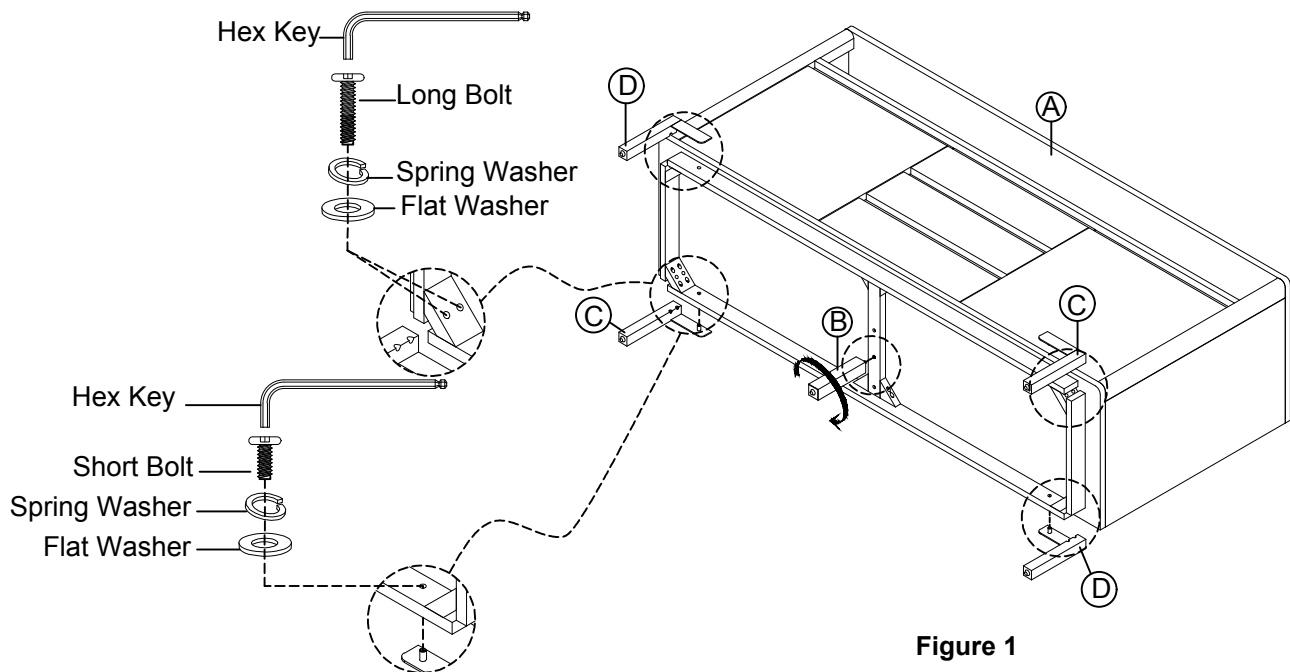

Figure 1

STEP 2

Tilt the Left Shelf (E) and place it inside the Buffet (A). Repeat this step on the other Left Shelf (E). (See Figure 2 & 3.)

Note: Shelves can be used with Flat Face on top or Wine Storage Face on top depending on what is needed.

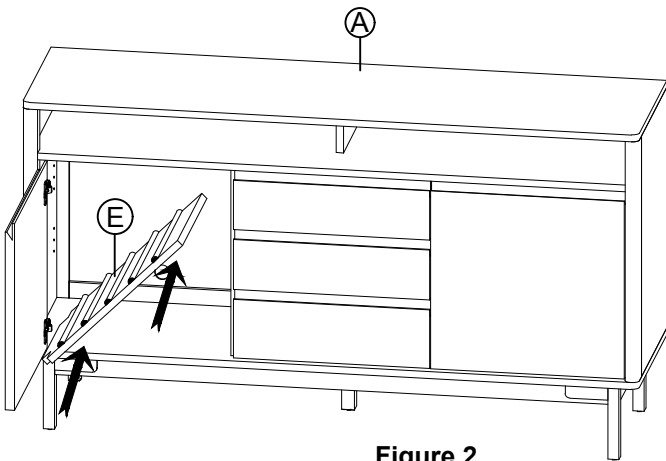

Figure 2

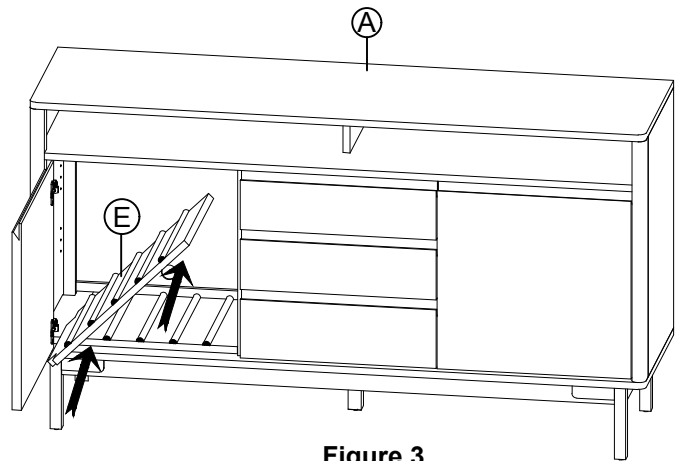

Figure 3

STEP 3

1. Lift the upper Left Shelf (E) up, then attach 4 Shelf Support (6) into the hole
2. Place the upper Left Shelf (E) on the Shelf Support (6). (See Figure 4.)

Repeat this step on lower Left Shelf (E). (See Figure 5.)

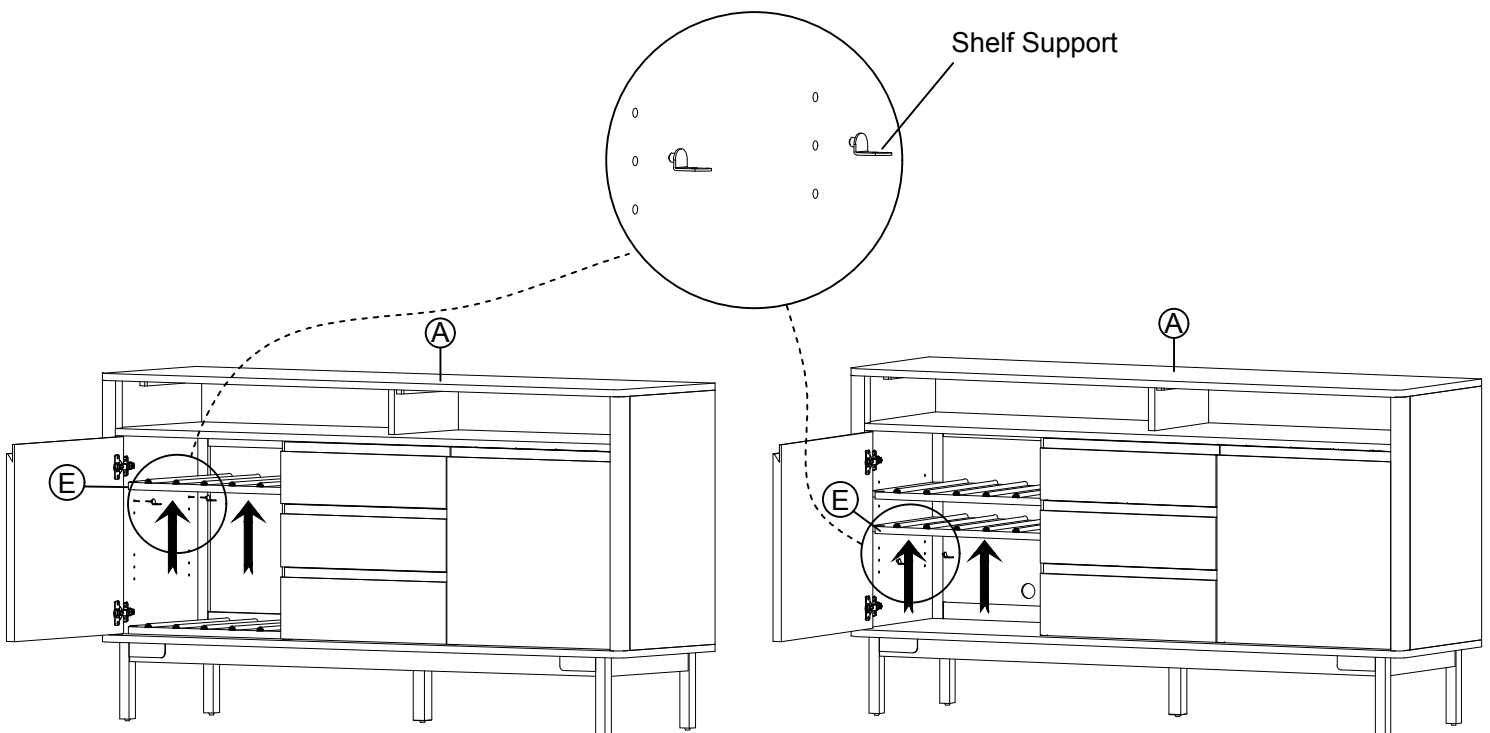
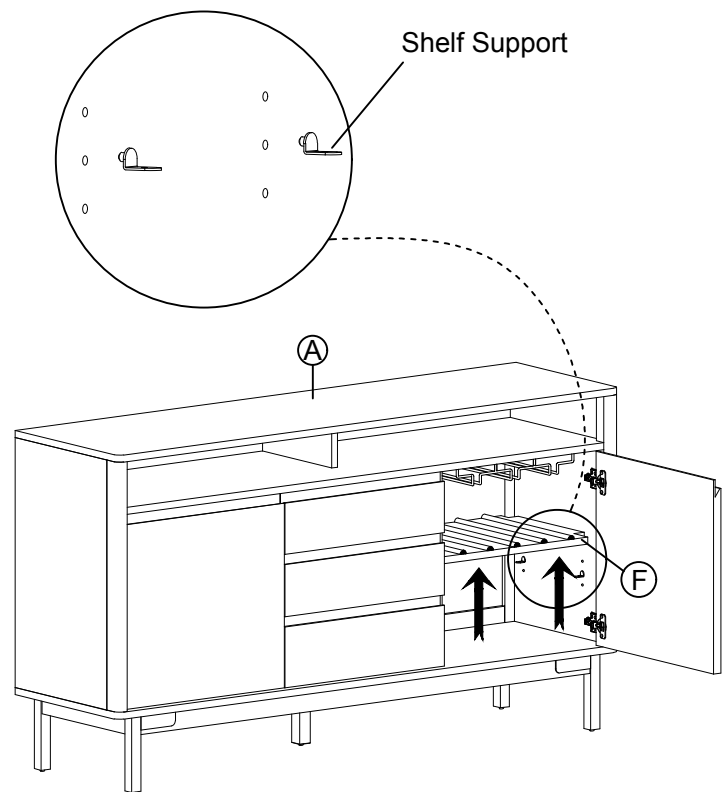
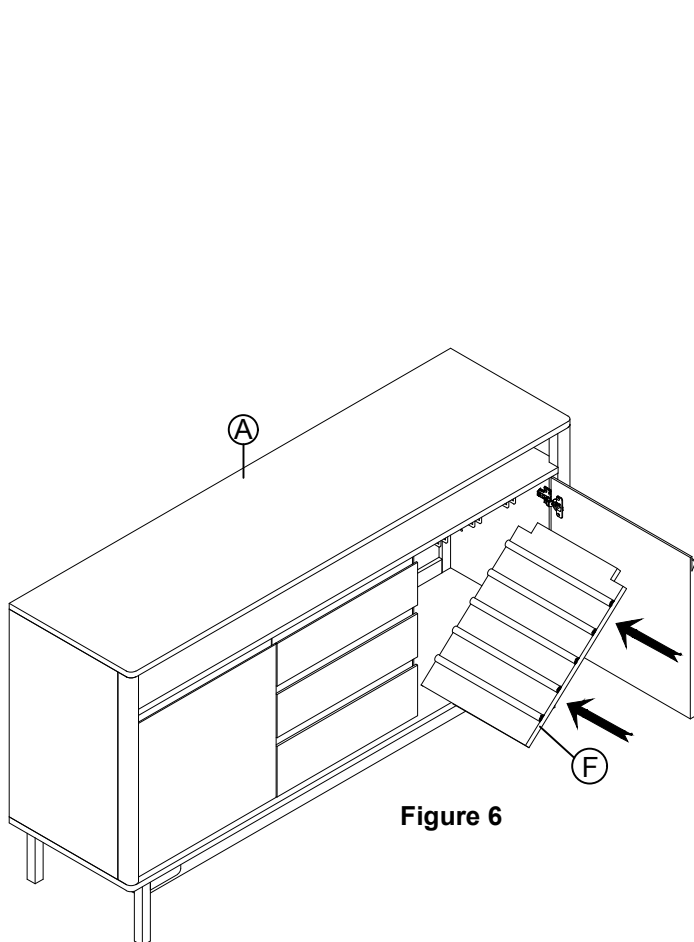

Figure 4

Figure 5

STEP 4

1. Tilt the Right Shelf (F) and place it lightly inside the Buffet (A). (See Figure 6.)
2. Lift the Right Shelf (F) up, then attach 4 Shelf Support (6) into the hole.
3. Place the Right Shelf (F) on the Shelf Support (6). (See Figure 7.)



STEP 5

Adjust the levelers on the legs until the furniture is leveled.

Use with wine storage face shelf

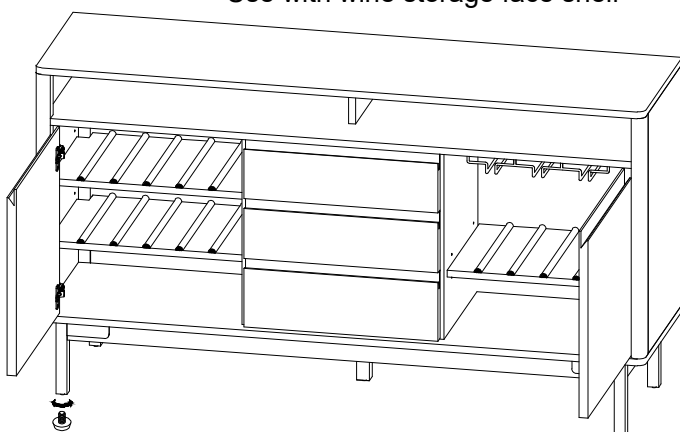

Adjustable Levelers

Use with flat face shelf

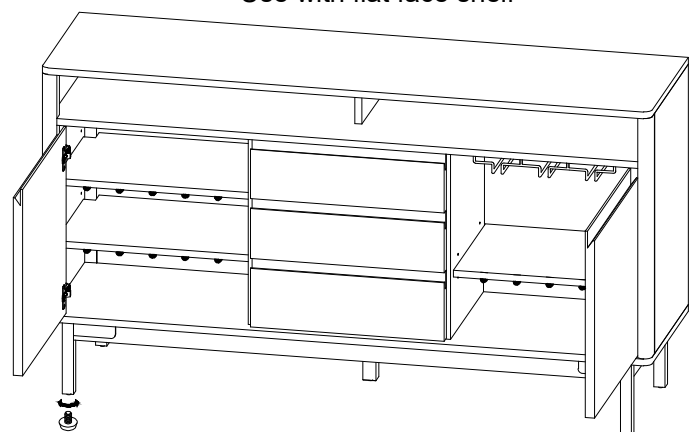

Adjustable Levelers

IMPORTANT NOTES

POSITION THE ANTI-TIPPING RESTRAINT AS CLOSE AS POSSIBLE TO THE TOP CENTER BACK OF THE CASE.

REFER TO TIPPING KIT MANUFACTURER'S INSTRUCTIONS FOR ATTACHMENT

- Phillips screwdriver (not included) is required for assembling anti tipping kit.
- Assembly and installation of tip restraint by two adults is highly recommended.

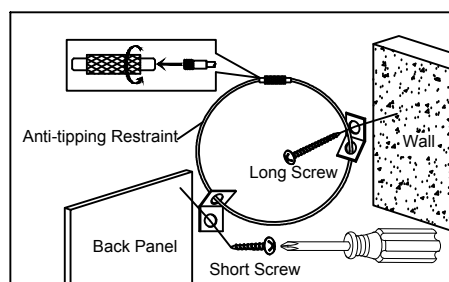

Anti-tipping Hardware is pre-attached at back panel

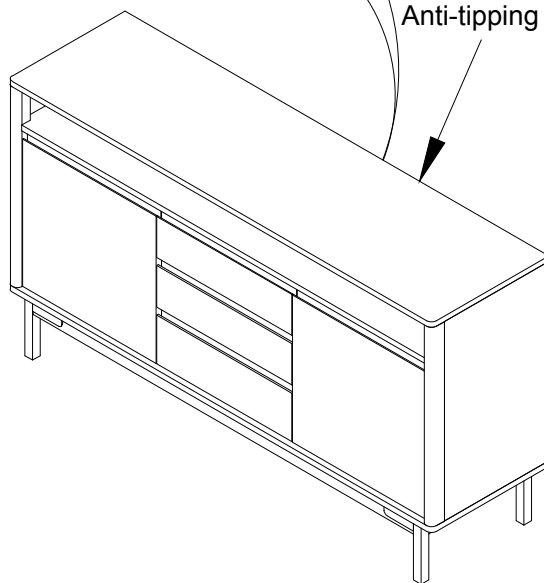

CARE INSTRUCTIONS

- To avoid scratches, do not place sharp or jagged objects directly on the table top.
- Do not place hot items directly on the tabletop.
- Use placemats or trivets under hot items and coasters under beverages to prevent marks and stains.
- Avoid the use of harsh chemicals or abrasive cleaning materials.
- Wipe the table clean with a soft, dry cloth after each use.
- Wipe up spills quickly with a soft, dry cloth.

Flexsteel Industries, Inc.

For Parts or Customer Service call toll-free: 1-888-415-3979

Monday-Friday, 8:00-5:00pm Central Time

Email: customersolutions@flexsteel.com

www.flexsteel.com