

# Model 161-WV24C/ WF24C Wood and Swivel Counter Stool

## Parts Listing

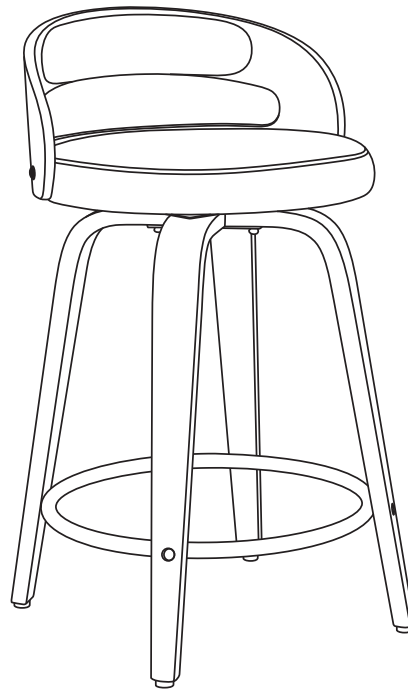

## Assembly Instructions

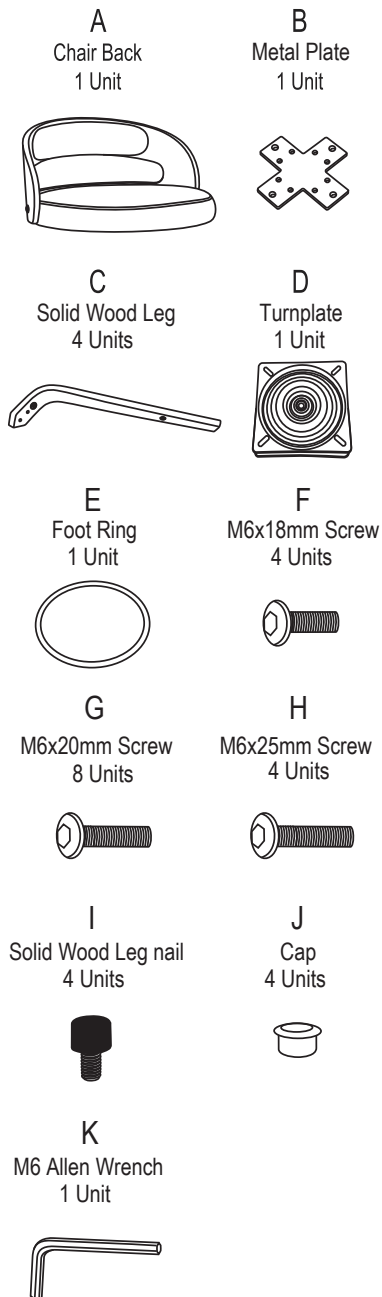

**Tools Needed: Allen Wrench - Provided**

*Please read all instructions before assembly.*

**Step 1:** Attach metal plate(B) to four Solid Wood Legs(C) , using four M6x20mm Screw(G) first as shown.Tighten with M6 Allen Wrench (K). Do not fully tighten screws.

**Step 2:** Attach Foot Ring(E) to four Solid Wood Legs(C) , using four M6x25mm Screws(H) as shown.Tighten with M6 Allen Wrench (K).Do not fully tighten screws.

**Step 3:** Install the nail(I) at the bottom of the Solid Wood Legs(C) .Tighten the screws fully.

**Step 4:** Attach Turnplate(D) to four Solid Wood Legs (C) , using four M6x20mm Screws(G) as shown.Tighten with M6 Allen Wrench (K).

**Step 5:** Attach Turnplate(D) to Chair Back(A),using four M6\*18mm Screws (F) as shown. Tighten with M6 Allen Wrench (K).And then put the four Caps(J) on the Solid Wood Legs(C) as shown.

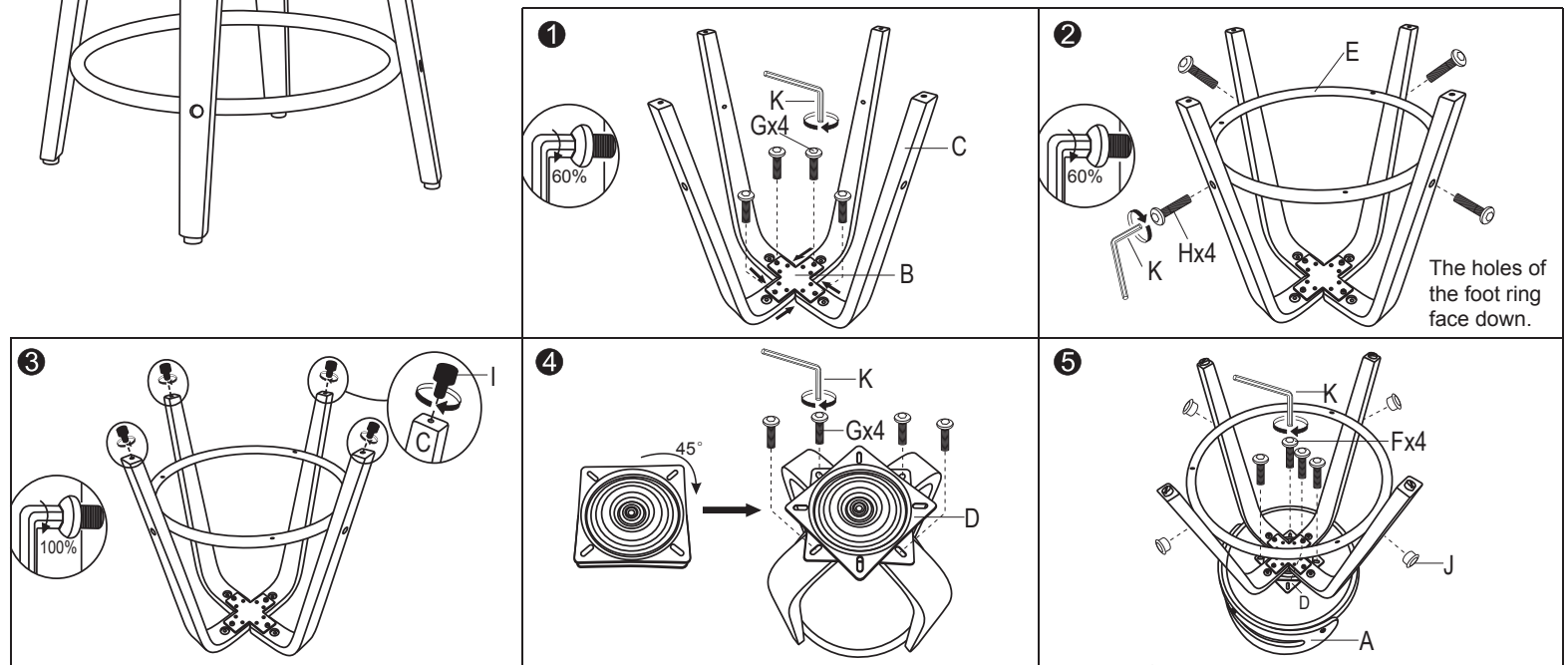

**WEIGHT CAPACITY: 275 lbs.**

### Assembly Notes:

During assembly, hand tighten screw only when all screws are in place, you may then tighten all screws completely.

### CAUTION:

1. Do not use this chair as a step ladder.
2. Check for loose screws and tighten them every 6 months.

161 Tradition Trail Holly Springs, NC, 27540  
800-520-7471 (voice) 919-362-4765 (fax)  
919- 303-6389 (voice) www.ofminc.com  
support@ofminc.com



Essentials  
BY OFM

CONTROL INSTRUCTIONS
INSTRUCCIONES DEL CONTROL
INSTRUCTIONS DE RÉGLAGE

## 161-WV24C/WF24C

