

TRAP PRIMERS

AUTOMATIC TRAP PRIMER - *LEAD FREE

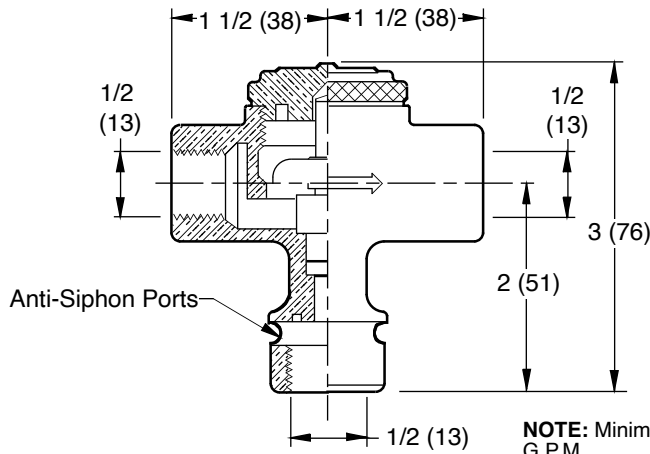

Fig. 2699LF
 1/2" (13) NPT Female

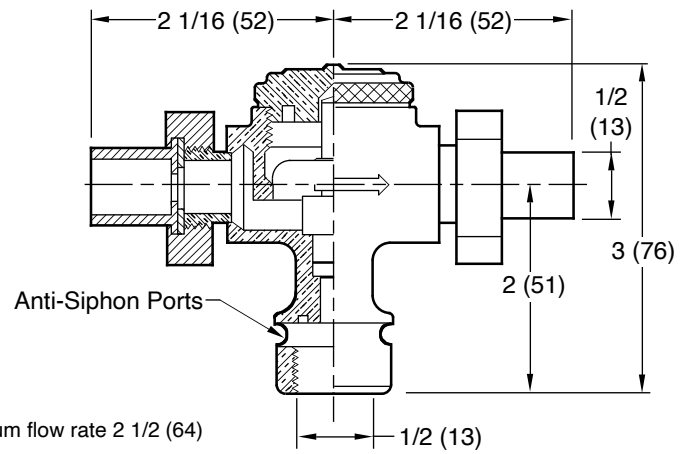

Fig. 2699-1LF
 1/2" (13) Copper Sweat

NOTE: Minimum flow rate 2 1/2 (64) G.P.M.

NOTE: Dimensions shown in parenthesis are in millimeters.

OPTIONAL MATERIALS:
 Satin Finish Chrome Plated -CP

REGULARLY FURNISHED:
 *Lead Free Cast Bronze with 1/2" (13) Connection as indicated by Figure Number Selected.

NOTE: MUST BE LOCATED IN AN ACCESSIBLE LOCATION.

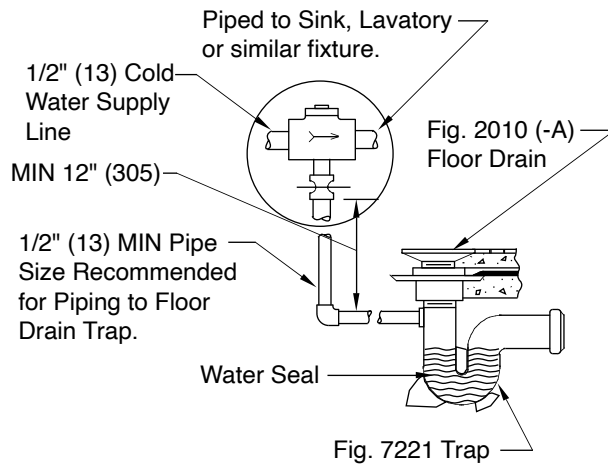

APPLICATION, INSTALLATION AND OPERATING PRINCIPLE

The Smith Trap Seal Primer Valve, when properly installed in a cold water supply line, running to a frequently used fixture and connected to a floor drain trap, provides a constant seal of fresh water in the drain trap.

When water is drawn at the plumbing fixture the resulting flow activates the Trap Primer valve mechanism. A pulse of water is dispensed into the trap at the beginning and end of flow in the fixture supply line.

Air ports in the primer body prevent siphonage of trap water and backflow into the potable water supply line.

If the trap water seal is not constantly maintained, the water will evaporate from the trap, allowing sewer gas to escape into building from the sewer lines.

* **COMPLIES with LEAD PLUMBING LAW**
 "CERTIFIED by IAPMO R & T"
 FILE NO. 8477
 (NSF/ANSI 372)



DRAWING NUMBER: S2699LF
 SIZE: A
 SCALE: NONE
 DATE: 5-17-85
 APPROVED BY: TD
 CHECKED BY: TD
 DRAWN BY: PJ
 FIGURE NUMBER: 2699LF, 2699-1LF
 DIMENSIONS ARE SUBJECT TO MANUFACTURERS TOLERANCE AND CHANGE WITHOUT NOTICE
 WE CAN ASSUME NO RESPONSIBILITY FOR USE OF SUPERSEDED OR VOID DATA

REV.	DATE	DESCRIPTION	BY	CKD. BY	WEIGHT POUNDS	VOLUME CUBIC FEET	FIGURE NUMBER
	6-29-23	Added *Lead Free/LF	HS	CL			2699LF, 2699-1LF
	10-25-13	Added File No. 8477 Note	TBW	JM			
	01/20/11	Updated Logo	JJ	TW			
	04/17/03	Changed Text	JJ	CL			

2699LF INST
 DRAWING NUMBER
 S2699LF INST
 SIZE
 A
 SCALE:
 NONE
 DATE:
 3-27-95
 APPROVED BY:
 BS
 CHECKED BY:
 WMS
 DRAWN BY:
 EMB
 FIGURE NUMBER

DIMENSIONS ARE SUBJECT TO MANUFACTURERS TOLERANCE AND CHANGE WITHOUT NOTICE
 WE CAN ASSUME NO RESPONSIBILITY FOR USE OF SUPERSEDED OR VOID DATA

SMITH® JAY R. SMITH MFG. CO.®
 MEMBER OF MORRIS GROUP INTERNATIONAL
 POST OFFICE BOX 3237
 MONTGOMERY, ALABAMA 36109-0237 (USA)
 TEL: 334-277-8520 FAX: 888-377-7818 www.jrsmith.com

MEMBER OF:



LOCATION
ATTENTION INSTALLER: After Installation, Please Leave This Instruction Sheet For Occupant's Information.

INSTRUCTIONS FOR INSTALLING 2699 WATER SAVING TRAP PRIMER

INSTALLATION

The 2699LF Trap Primer should be connected to the cold line only. For effective priming it should never be connected to a dual hot and cold combination faucet unless the minimum flow on the cold demand exceeds the amount listed on the chart at various operating pressures. See Chart A. Do not install on a cold line serving a drinking fountain only.

These devices should be installed in the horizontal position, as shown, on the supply line leading to a frequently used fixture. Before installing 2699LF, be sure to flush out the line to remove dirt and scale which might lodge on the valve seat and disc. Device should be installed a minimum of 12" (305) above the trap and should be accessible for servicing. Maximum supply pressure 125 psi.

Note: For supply pressures below 20 psi consult factory.

... HOW IT WORKS

Smith Fig. No. 2699LF is a unique design which assures delivery of water to the trap to assure against evaporation of the water seal. Fig. No. 2699LF operates by the water flow acting against the main reaction disc (1), which forces the reaction disc in the upward position and removes the trap disc (2) from the plastic trap seat (3). A spurt of water is then delivered to the trap. However, with increased flow, the main reaction disc continues to lift and seals off the closing ring (4) to stop flow to the trap. When the flow through the valve is stopped, the trap disc (2) is returned to the closed position, and in the process, delivers a spurt of water to the trap before closing off.

The importance of this design is that a complete flow cycle through the valve from open to close will actuate the primer twice with two definite pulses; once on opening and once on closing, thus providing a tremendous water savings over competitive modes.

Fig. No. 2699LF is furnished with 1/2" (13) NPT female inlet and outlet connections. Fig. No. 2699-1LF is furnished with 1/2" (13) union sweat connections.

LIMITED WARRANTY: The Company warrants each product against defects in material and workmanship for a period of one year from the date of original shipment. In the event of such defects within the warranty period, the Company will, at its option, replace or recondition the product without charge. This shall constitute the exclusive remedy for breach of warranty, and the installation, damages or other costs resulting from labor charges, delays, vandalism, negligence, fouling caused by foreign material, damage from adverse air conditions, chemicals, or any other circumstances over which the Company has no control. This warranty shall be invalidated by and abuse, misuse, misapplication of improper installation of the product. THE COMPANY MAKES NO OTHER WARRANTIES EXPRESS OF IMPLIED EXCEPT AS PROVIDED IN THIS LIMITED WARRANTY.

CHART A

Inlet Pressure	25	50	75	100	125
*GPM	1.1	1.6	2.0	2.3	2.4

*Minimum cold flow required for proper trap priming.

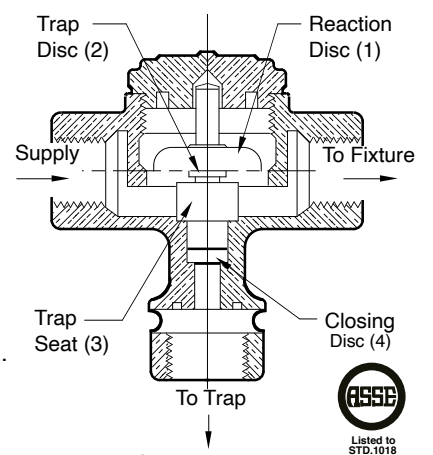

Annual inspection of all water system safety and control valves is required and necessary. Regular inspection, testing and cleaning assures maximum life and proper product function.

TYPICAL INSTALLATIONS

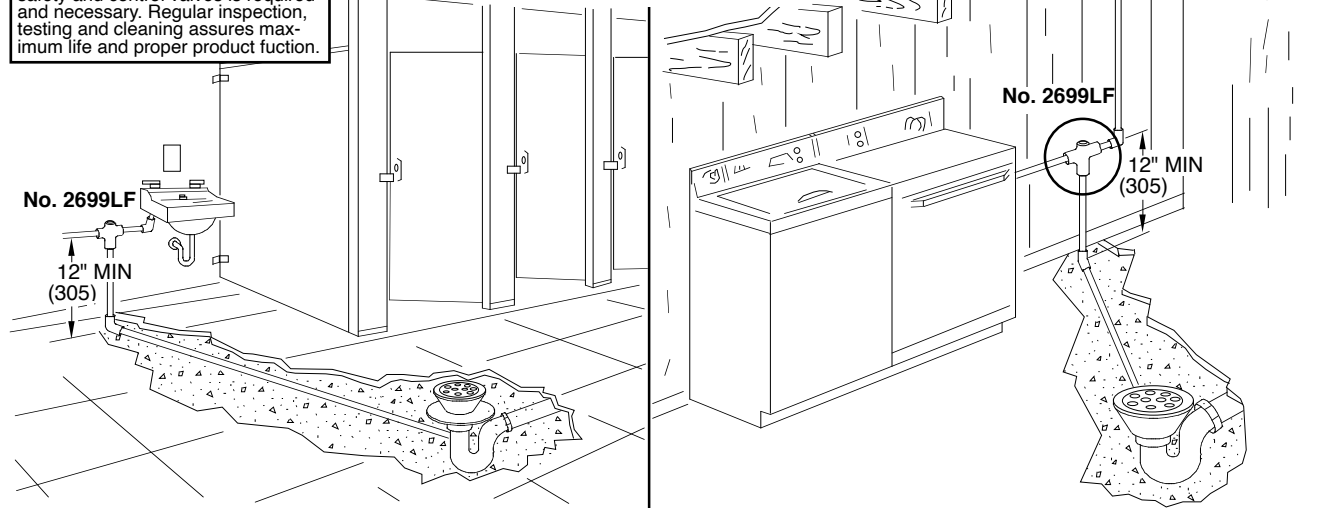

F	6/29/23	Added LF	HS	CL	WEIGHT POUNDS	VOLUME CUBIC FEET	FIGURE NUMBER 2699LF INST
E	01/20/11	Updated Logo	JJ	TW			
D	04-17-03	Modified Text	JJ	CL			
C	07-19-01	Added Notes & Dimension	RN	SJM			
REV.	DATE	DESCRIPTION	BY	CKD. BY			