

PARTS DIAGRAM 468301321, 468302321, 468301321UK

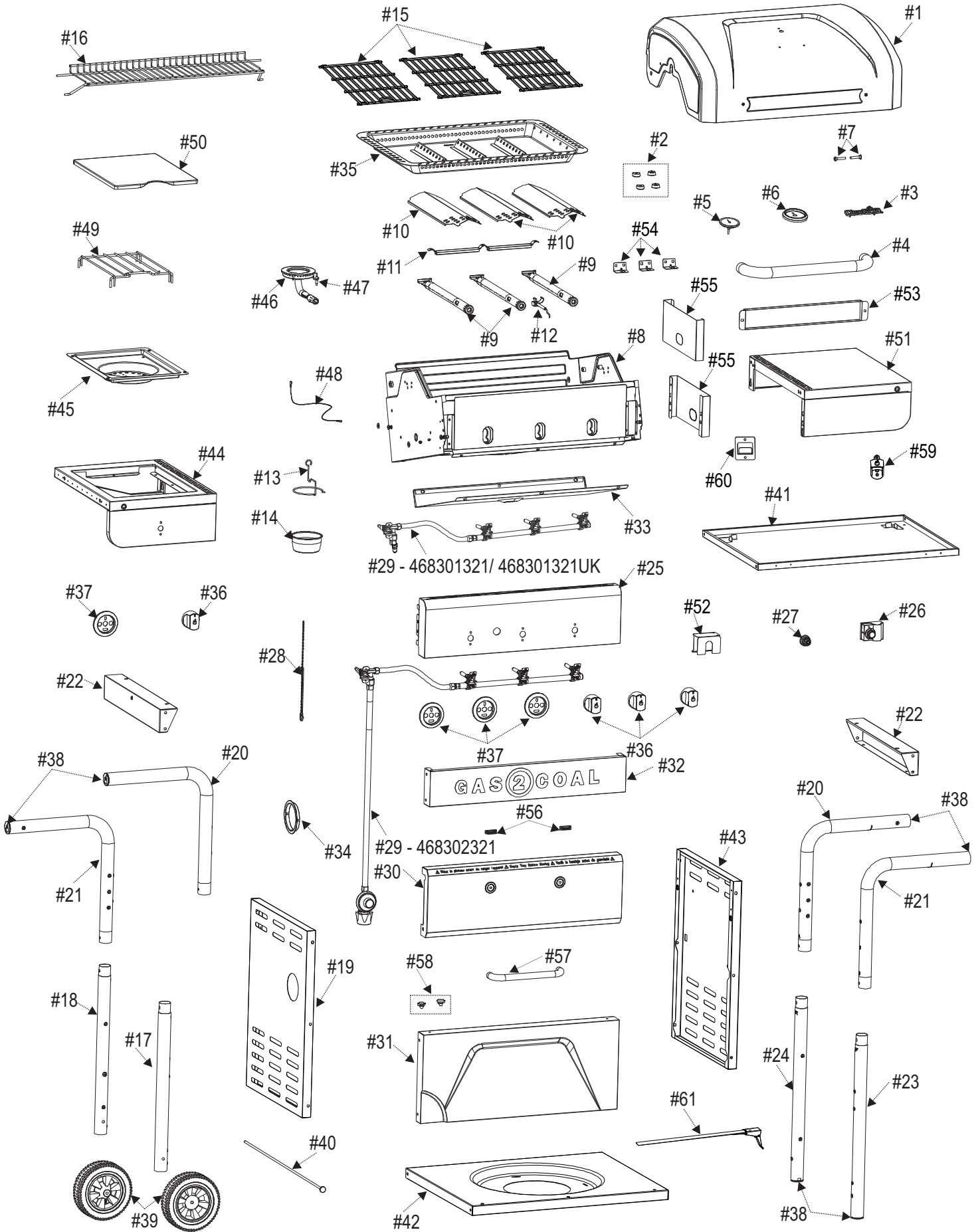

PARTS LIST 468301321, 468302321, 468301321UK









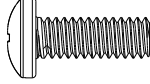
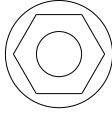
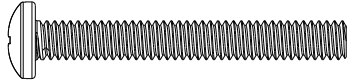
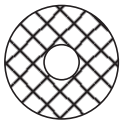

Key	Qty	Description
1	1	TOP LID
2	4	LID BUMPER
3	1	LOGO PLATE
4	1	HANDLE
5	1	TEMPERATURE GAUGE
6	1	BEZEL, TEMPERATURE GAUGE
7	1	HARDWARE F/ TOP LID
8	1	FIREBOX
9	3	BURNER
10	3	HEAT TENT
11	2	FLAME CARRYOVER TUBE
12	1	ELECTRODE
13	1	GREASE CUP CLIP
14	1	GREASE CUP
15	3	COOKING GRATE
16	1	SWINGAWAY RACK
17	1	LEG, LEFT LOWER FRONT
18	1	LEG, LEFT LOWER REAR
19	1	LEFT SIDE PANEL, F/ CART
20	2	UPPER CART FRAME A
21	2	UPPER CART FRAME B
22	2	UPPER CART BRACE
23	1	LEG, RIGHT LOWER FRONT
24	1	LEG, RIGHT LOWER REAR
25	1	CONTROL PANEL
26	1	ELECTRONIC IGNITION MODULE
27	1	BUTTON, F/ EI MODULE
28	1	MATCH HOLDER
29	1	VALVE ASSEMBLY
30	1	FRONT PANEL, DOOR, NO HANDLE
31	1	FRONT PANEL, LOWER
32	1	FRONT PANEL, UPPER
33	1	HEAT SHIELD, TANK
34	1	GROMMET, F/ REGULATOR HOLE
35	1	CHARCOAL TRAY
36	4	CONTROL KNOB
37	4	BEZEL, F/ CONTROL KNOB
38	6	END CAP, F/ LEG
39	2	WHEEL

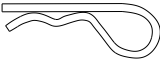
Key	Qty	Description
40	1	AXLE
41	1	STORAGE TRAY
42	1	BOTTOM SHELF
43	1	RIGHT SIDE PANEL, F/ CART
44	1	HOT PLATE SHELF
45	1	DRIP PAN, F/ HOT PLATE
46	1	HOT PLATE
47	1	ELECTRODE, F/ HOT PLATE
48	1	IGNITOR WIRE, F/ HOT PLATE
49	1	HOT PLATE GRATE
50	1	HOT PLATE LID
51	1	RIGHT SHELF ASSEMBLY
52	1	HEAT SHIELD, F/ EI MODULE
53	1	HEAT SHIELD, F/ HANDLE
54	3	BURNER BRACE
55	2	HEAT SHIELD, F/ FIREBOX
56	1	MAGNET, F/ DOOR
57	1	HANDLE, F/ DOOR
58	2	BUMPER, F/ DOOR
59	1	BOTTLE OPENER
60	1	GRATE TOOL HOLDER
61	1	TANK STRAP

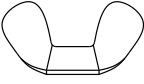
NOT Pictured

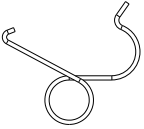
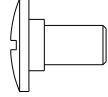
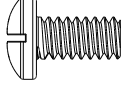
...	1	HARDWARE PACK
...	1	PRODUCT GUIDE, EUROPE
...	1	RETAINER CLIP, F/ HOT PLATE
...	1	GRATE TOOL

HARDWARE LIST

Key	Description	Picture	Qty
A	1/4-20x3/4" Machine Screw		48
B	1/4-20 Flange Nut		8
C	1/4-20x2" Machine Screw		4
D	7x15 Fiber Washer		4
E	Bushing		1
F	Hitch Pin Clip		1
G	#8-32x3/8" Machine Screw		2
H	Wing Nut		1
J	5mm Fiber Washer		1
K	Venturi Clip		1
L	Shoulder Screw		2
M	#10-24x3/8" Machine Screw		2
N	5mm Lock Washer		2
P	5mm Flat Washer		2
Q	#10-24x3/8" Screw		2
R	#10-24 Flange Nut		2