

SIDES	BOTTOM
4 1/2" KNOCKOUTS	2 1/2" KNOCKOUTS
2 3/4" KNOCKOUTS	2 3/4" MOON KNOCKOUTS
2 PCS #8-32×1/2" Screws Installed	
2 PCS #6-202×1 7/8" Screws Installed	
Material: Steel-0.0625"-G60 Galvanized	

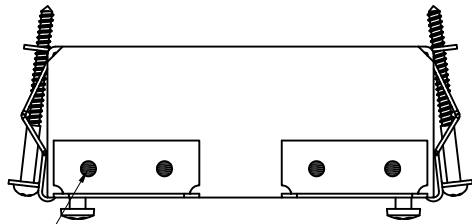

8 PLACES SPOT WELDING

#8-32, ×2

#6-20, ×2

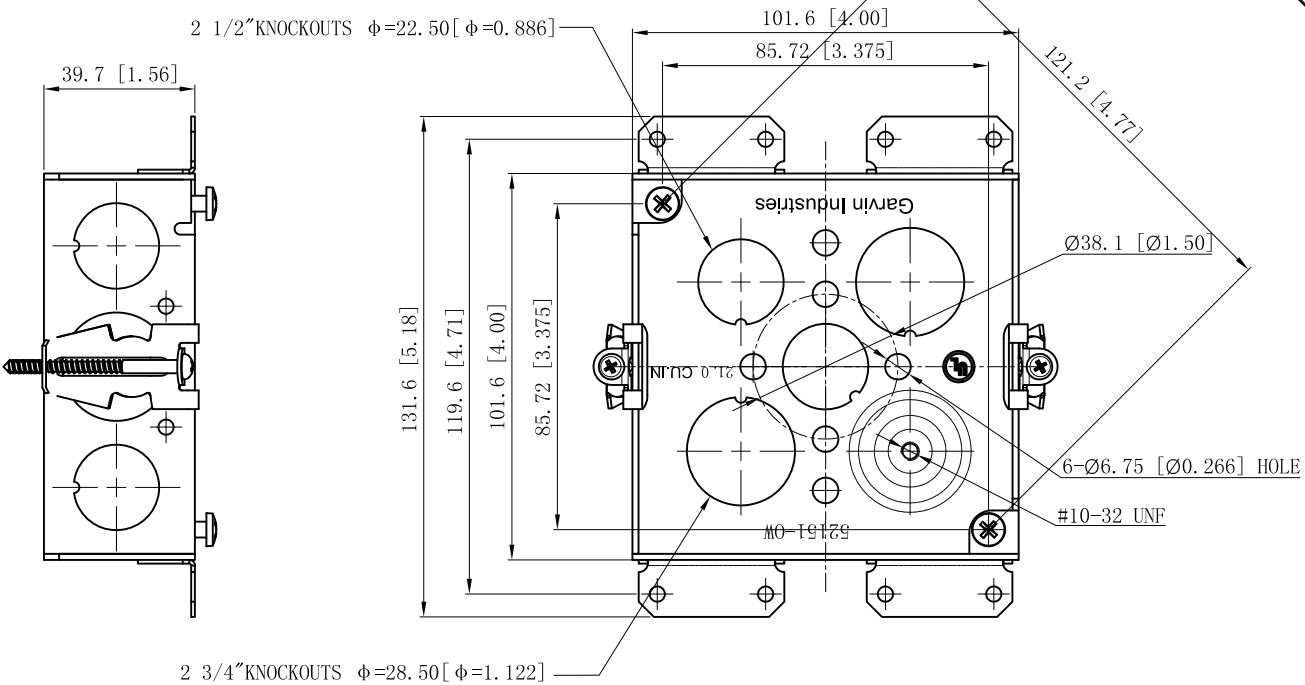
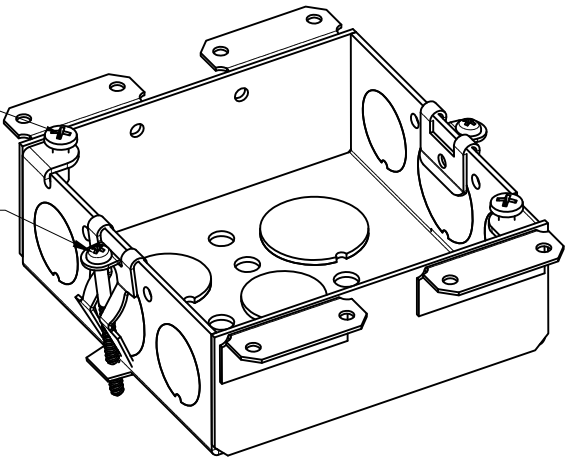

DESCRIPTION
TRADE REFERENCE TERMS

This data sheet is for reference only. GARVIN INDUSTRIES reserves the right to make changes to the design without prior notice.

STANDARD PACKING	<h1 style="text-align: center;">GARVIN INDUSTRIES</h1> <h2 style="text-align: center;">4" SQUARE BOXES 1-1/2" DEEP</h2>		
TITLE			
SIZE	DWG NO.	52151-OW	REV
A4		DATA SHEET	