

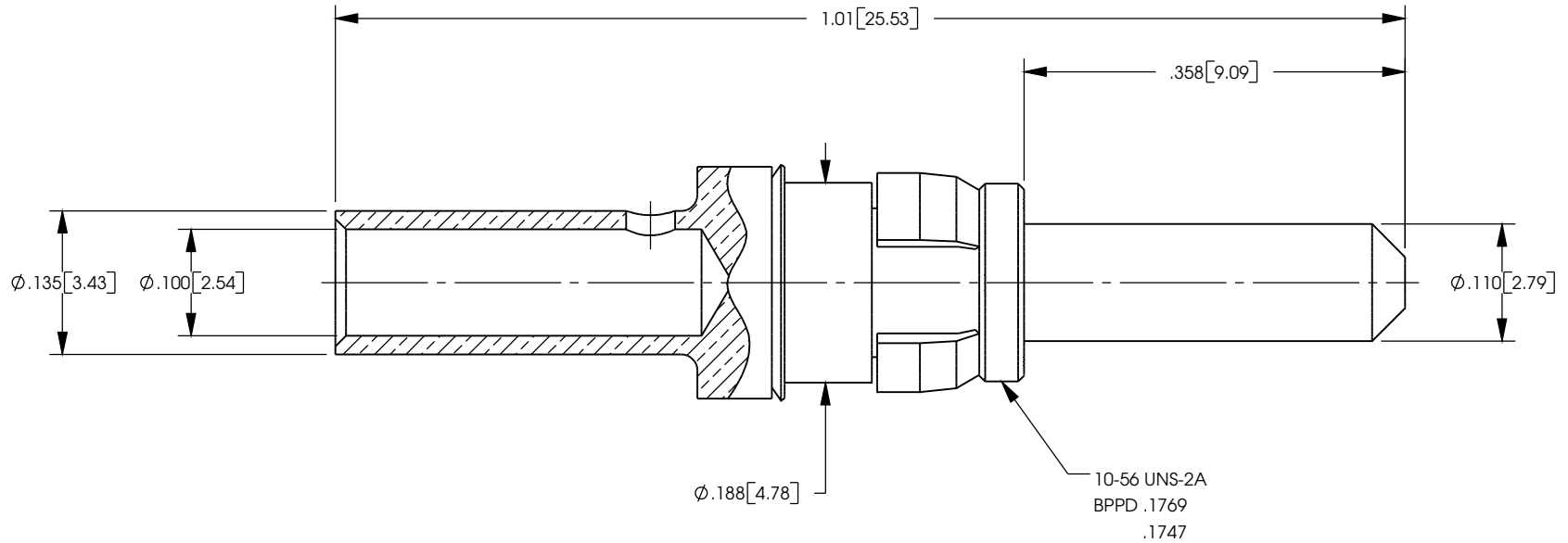

NOTES: UNLESS OTHERWISE SPECIFIED

1. MATERIALS:  
 BODY: BRASS PER ASTM 316  
 CLIP RING: BERYLLIUM COPPER PER ASTM B194  
 SPRING WASHER: PHOSPHOR BRONZE PER ASTM B103
2. FINISH:  
 BODY: .000030 MIN. GOLD PER MIL-G-45204 OVER  
 .000050 MIN. NICKEL PER QQ-2-290  
 CLIP RING: .000100 MIN. NICKEL PER QQ-N-290  
 OVER COPPER FLASH  
 SPRING WASHER: .000005 MIN. GOLD PER MIL-G-45204 OVER  
 .000005 MIN. NICKEL PER QQ-N-290
3. ELECTRICAL:  
 CURRENT RATING: 20 AMPS
4. FOR USE WITH 12 AWG WIRE OR EQUIVALENT

REV	DESCRIPTION	BY DATE	APPD
01	ER347	RDG 02/15/06	XXX



CATALOG P/N: 220-910-0008G

PER ASME Y14.5M-1994 UNLESS OTHERWISE SPECIFIED: DIMENSIONS ARE IN INCHES (MM) TOLERANCES: DECIMAL: XX ± .01 (0.3) .XXX ± .005 (0.13) .XXXX ± .XXXX ANGLES: ± 2°      SCALE: 6:1		<b>NORTHROP GRUMMAN</b>  <b>Winchester Electronics</b> 62 Barnes Industrial Road North Wallingford, CT 06492	
<b>CUSTOMER DRAWING</b>		 RDM HIGH POWER PLUG 10/20 AMP	
DRAWN	DATE	APPROVED	DATE
RDG	02/15/06	XXX	XX/XX/XX
APPROVED	DATE	APPROVED	DATE
XXX	XX/XX/XX	XXX	XX/XX/XX
<b>A</b> SD220-910-0008		SHT 1 of 1	REV 01