

# PALMGREN®

## 6" x 10" & 6" x 14" BELT & DISC SANDERS



Model 9681109  
6"x10" Belt & Disc Sander



Model 9681108  
6"x14" Belt & Disc Sander

***Read carefully and follow all safety rules and operating instructions before first use of this product.***

## DESCRIPTION

Palmgren Model 9681109 6" x 10" Belt Disc Sander with stand and Model 9681108 6" x 14" Belt Disc Sander with cabinet are constructed of rugged cast iron and heavy gauge steel providing stability and vibration-free operation. The belt disc sanders are used to sand, deburr, bevel and grind large workpieces of wood, plastic and metal.

The belt housing can be pivoted from vertical to horizontal for sanding large, straight workpieces. The belt assembly includes a tilting cast iron table that tilts out 45°, miter gauge and 4" dust collection chute.

The 10" or 14" disc can be used to sand or bevel surfaces with the use of a cast iron table that tilts out 45° and in 20°, miter gauge slot and 4" dust collection chute.

The 3" diameter idler drum permits the sanding of contoured shapes and finishes by positioning the adjustable platen from a horizontal to vertical position.

The collection chutes accept the standard 4" dust collection hose for quick removal of dust. The adjustable miter gauge can be used on both the belt and disc tables for guiding the workpiece at a desired angle while sanding.

## UNPACKING

Refer to Figure 1.

Check for shipping damage. If damage has occurred, a claim must be filed with carrier. Check for completeness. Immediately report missing parts to dealer.

The sander comes assembled as one unit. Additional parts which need to be fastened to sander, should be located and accounted for before assembling.

- A Abrasive Disc 100X
- C Miter Gauge Assembly
- D Workstop
- F Intake Port Cap
- Parts Bag

Parts bag includes: one 8mm flat washer, four foot rest assemblies, 6mm hex wrench and 4mm long hex wrench.

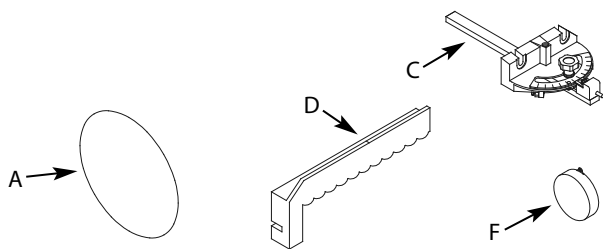

**Figure 1 – Unpacking sander.**

## SPECIFICATIONS

	<b>9681109, 6"x10"</b>	<b>9681108, 6"x14"</b>
Belt Platen Area (W x L)	6-3/4" x 14-1/2"	6-3/4" x 14-1/2"
Belt Table Dim. (W x D)	8-5/8" x 6.0"	8-5/8" x 6.0"
Belt Table Tilts	45 degree	45 degree
Dust Chute Size	4"	4"
Belt Speed (SFPM-60 Hz)	2258 FPM	2258 FPM
Disc Diameter	10" (PSA)	14" (PSA)
Disc Table Dim (W x D)	11-1/4" x 7-1/4"	15-5/8" x 7-1/4"
Disc Table Tilt	45 degree	45 degree
Disc Speed (RPM)	1720	1720
Stand Dim (L x W x H)	24¾" x 19" x 21¼"	N/A
Cabinet Dim (L x W x H)	N/A	17½" x 20" x 28"
HP	1.0 HP	1.5 HP
Voltage	115/230	115/230
RPM	1720	1720
Phase	1	1
Amps	9.5/4.75	12.5/6.25
Assembled Wt.	141 lbs.	180 lbs.
Assembled Dim (L x W x H)	29.3"x18.3"x51.8"	30.7"x20"x51"
Shipping Weight	178.5 lbs.	236 lbs.
Shipping Dim (L x W x H)	30"x19"x34.8"	31.5"x22"x56.3"

## SAFETY RULES

**WARNING:** For your own safety, read all of the instructions and precautions before operating tool.

**CAUTION:** Always follow proper operating procedures as defined in this manual even if you are familiar with use of this or similar tools. Remember that being careless for even a fraction of a second can result in severe personal injury.

**WARNING:** Some dust created by power sanding, sawing, grinding, drilling and other construction activities contains chemicals known to the state of California to cause cancer, birth defects or other reproductive harm.

Some examples of these chemicals are:

- Lead from lead-based paints.
- Crystalline silica from bricks and cement and other masonry products.
- Arsenic and chromium from chemically-treated lumber.

Your risk from these exposures vary, depending on how often you do this type of work. To reduce your exposure to these chemicals: work in a well ventilated area and work with approved safety equipment. Always wear **OSHA/NIOSH** approved, properly fitting face mask or respirator when using such tools.

### BE PREPARED FOR JOB

- Wear proper apparel. Do not wear loose clothing, gloves, neckties, rings, bracelets or other jewelry which may get caught in moving parts of machine.
- Wear protective hair covering to contain long hair.
- Wear safety shoes with non-slip soles.
- Wear safety glasses complying with United States ANSI Z87.1. Everyday glasses have only impact resistant lenses. They are **NOT** safety glasses.
- Wear face mask or dust mask if operation is dusty.
- Be alert and think clearly. Never operate power tools when tired, intoxicated or when taking medications that cause drowsiness.

**SAFETY RULES (CONTINUED)****PREPARE WORK AREA FOR JOB**

- Keep work area clean. Cluttered work areas and work benches invite accidents.
- Do not use power tools in dangerous environments. Do not use power tools in damp or wet locations. Do not expose power tools to rain.
- Work area should be properly lighted.
- Proper electrical receptacle should be available for tool. Three-prong plug should be plugged directly into properly grounded, three-prong receptacle.
- Extension cords should have a grounding prong and the three wires of the extension cord should be of the correct gauge.
- Keep visitors at a safe distance from work area.
- Keep children out of the workplace. Make workshop childproof. Use padlocks, master switches or remove switch keys to prevent any unauthorized use of power tools.

**TOOL SHOULD BE MAINTAINED**

- Always unplug tool prior to inspection.
- Consult manual for specific maintaining and adjusting procedures.
- Keep tool lubricated and clean for safest operation.
- Remove adjusting tools. Form habit of checking to see that adjusting tools are removed before switching machine on.
- Keep all parts in working order. Check to determine that the guard or other parts will operate properly and perform their intended function.
- Check for damaged parts. Check for alignment of moving parts, binding, breakage, mounting and any other condition that may affect a tool's operation.
- A guard or other part that is damaged should be properly repaired or replaced. Do not perform makeshift repairs. (Use the parts list to order replacement parts.)

**KNOW HOW TO USE TOOL**

- Use right tool for job. Do not force tool or attachment to do a job for which it was not designed.
- Disconnect tool from power when changing abrasive belt or disc.
- Avoid accidental start-up. Make sure that the switch is in the OFF position before plugging in.
- Do not force tool. It will work most efficiently at the rate for which it was designed.
- Keep hands away from moving parts and sanding surfaces.
- Never leave tool running unattended. Turn the power off and do not leave tool until it comes to a complete stop.
- Do not overreach. Keep proper footing and balance.
- Never stand on tool. Serious injury could occur if tool is tipped or if belt or disc are unintentionally contacted.
- Know your tool. Learn the tool's operation, application and specific limitations.

- Handle workpiece correctly. Protect hands from possible injury.
- Turn machine off if it jams. Belt jams when it digs to deeply into workpiece. (Motor force keeps it stuck in the work).
- Support workpiece with miter gauge, belt platen or work table.
- Maintain 1/16" maximum clearance between table and sanding belt or disc.

**CAUTION:** Think safety! Safety is a combination of operator common sense and alertness at all times when tool is being used.

**ASSEMBLY**

**CAUTION:** Do not attempt assembly if parts are missing. Use this manual to order replacement parts.

Before sander is assembled, a suitable location should be chosen. The sander with cabinet weighs approximately 200 lbs when completely assembled. They should be assembled on location.

- Sander needs to be set on a flat, level surface.
- Make sure there is ample room for moving the workpiece through the entire cut. There must be enough room that neither the operator nor the bystanders will have to stand in line while using the tool.
- Good lighting and correct power supply are also required for a proper work area.

**ADJUST BELT HOUSING TO VERTICAL POSITION**

1. Move to the front of the sander; loosen and remove four knobs.
2. Remove dust hoods.
3. Loosen both hex nuts on the belt housing casting. Do not take out hex nut.
4. Move to the rear of the sander and gently lift the belt housing up supporting the housing from both sides.
5. Lift belt housing until it is adjusted to the vertical position.
6. Tighten both hex nuts from the rear of the sander.
7. Replace dust hood and tighten knobs.

**ATTACH FOOT RESTS**

Required parts and hardware: Four foot rest assemblies.

**CAUTION:** Sander with cabinet weighs approximately 200 lbs. At least two people are required to attach foot rests.

1. Carefully tip the sander to raise cabinet from the floor just enough so that one foot rest with bolt can be positioned under the cabinet corner so that the bolt slides through the hole on the cabinet base. Slowly set the sander back to the floor. Repeat three more times to position one foot rest with bolt under each of the cabinet corner.
2. Loosen knob and open cabinet door.
3. Using the cabinet door opening, secure foot rests to cabinet using four flat washers and four hex nuts.
4. Make sure all the hex nuts are tight.
5. Close cabinet door and secure it with knob.

**ASSEMBLY (CONTINUED)****ATTACH BELT TABLE**

Refer to Figure 2.

Required parts and hardware: Belt table with trunnion, handle, and 8mm flat washer.

1. Position belt table on the belt housing so that the trunnion travels on the slide.
2. Set the belt table position so that the 0° mark on the trunnion is aligned with the pointer.
3. Secure belt table position using the handle and flat washer. Tighten handle into the threaded hole on the belt housing.

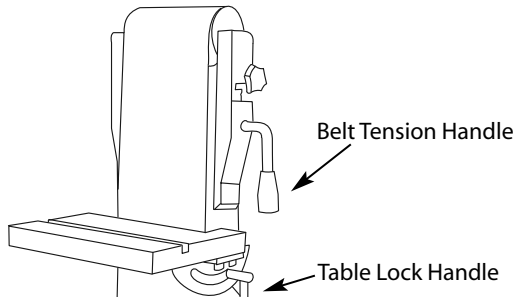

**Figure 2 – Attach belt table.**

Sander is shipped with the belt tension handle at the released position. Pull down the handle toward the belt table to tension the belt.

- Make sure that the clearance between the belt and belt table does not exceed 1/16".
- Wear protective glove and manually push the belt to verify that belt travels smoothly and without interference.

**POSITION DISC TABLE**

Required part: Handle

1. Sander is shipped with the disc table attached to the disc guard using a handle with flat washer one side and a hex head bolt with flat washer on the other side.
2. Loosen and remove hex head bolt and flat washer from the disc table.
3. Replace hex head bolt with the handle provided. Secure disc table to disc guard using the handle and flat washer.

**ATTACH ABRASIVE DISC TO CAST IRON DISC**

Refer to Figures 3 and 4.

Sander is shipped with the abrasive not applied to the cast iron disc.

1. Clean the cast iron disc if necessary prior to applying the abrasive.
2. Remove the adhesive cover from the back of the abrasive disc.
3. Slide the abrasive between the disc table and cast iron disc and center abrasive on the cast iron disc.

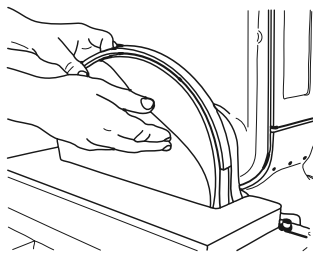

**Figure 3 – Attach abrasive disc.**

4. Apply pressure on abrasive to paste.
5. Make sure abrasive is pasted evenly on the cast iron disc.

6. Make sure that the clearance between disc table and abrasive disc does not exceed 1/16".
7. Use a straight edge or square to check if the disc table is at right angle to the disc.

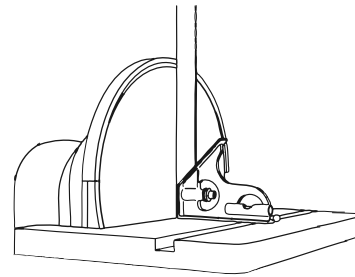

**Figure 4 - Check disc table.**

8. Wear a protective glove and manually turn the disc to verify that the disc turns freely and without interference.

**ATTACH MITER GAUGE**

Required part: Miter gauge assembly

Miter gauge is shipped completely assembled and can be used with the belt or disc tables.

- Slide miter gauge bar into the slot on belt or disc table.

**INSTALLATION**

Refer to Figures 5, 6 and 7.

**WARNING:** All electrical connections must be performed by a qualified electrician.

**POWER SOURCE**

The motor is designed for operation on the voltage and frequency specified. Normal loads will be handled safely on voltages not more than 10% above or below the specified voltage.

Running the unit on voltages which are not within the range may cause overheating and motor burnout. Heavy loads require that voltage at motor terminals be no less than the voltage specified on nameplate. Power supply to the motor is controlled by a single pole locking rocker switch. Remove the key to prevent unauthorized use.

**GROUNDING INSTRUCTIONS**

**WARNING:** Improper connection of equipment grounding conductor can result in the risk of electrical shock. Equipment should be grounded while in use to protect operator from electrical shock.

- Check with a qualified electrician if grounding instructions are not understood or if in doubt as to whether the tool is properly grounded.
- This tool is equipped with an approved 3-conductor cord rated at 300V and a 3-prong grounding type plug (See Figure 5) for your protection against shock hazards.
- Grounding plug should be plugged directly into a properly installed and grounded 3-prong grounding-type receptacle, as shown (Figure 5).

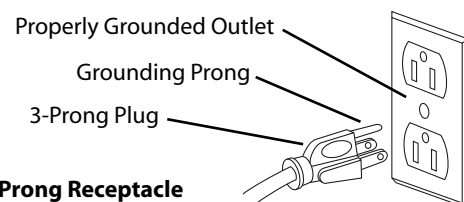

**Figure 5 – 3-Prong Receptacle**

**INSTALLATION (CONTINUED)**

- Do not remove or alter grounding prong in any manner. In the event of a malfunction or breakdown, grounding provides a path of least resistance for electrical shock.

**WARNING:** Do not permit fingers to touch the terminals of plug when installing or removing from outlet.

- Plug must be plugged into matching outlet that is properly installed and grounded in accordance with all local codes and ordinances. Do not modify plug provided. If it will not fit in outlet, have proper outlet installed by a qualified electrician.
- Inspect tool cords periodically, and if damaged, have repaired by an authorized service facility.
- Green (or green and yellow) conductor in cord is the grounding wire. If repair or replacement of the electric cord or plug is necessary, do not connect the green (or green and yellow) wire to a live terminal.
- Where a 2-prong wall receptacle is encountered, it must be replaced with a properly grounded 3-prong receptacle installed in accordance with National Electric Code and local codes and ordinances.

**WARNING:** This work should be performed by a qualified electrician.

- A temporary 3-prong to 2-prong grounding adapter (See Figure 6) is available for connecting plugs to a two pole outlet if it is properly grounded.

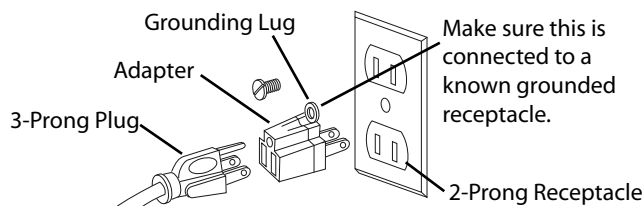

**Figure 6 – 2-prong receptacle with adapter.**

- Do not use a 3-prong to 2-prong grounding adapter unless permitted by local and national codes and ordinances. (A 3-prong to 2-prong grounding adapter is not permitted in Canada.) Where permitted, the rigid green tab or terminal on the side of the adapter must be securely connected to a permanent electrical ground such as a properly grounded water pipe, a properly grounded outlet box or a properly grounded wire system.
- Many cover plate screws, water pipes and outlet boxes are not properly grounded. To ensure proper ground, grounding means must be tested by a qualified electrician.

**EXTENSION CORDS**

- The use of any extension cord will cause some drop in voltage and loss of power.
- Wires of the extension cord must be of sufficient size to carry the current and maintain adequate voltage.
- Running the unit on voltages which are not within  $\pm 10\%$  of the specified voltage may cause overheating and motor burn-out.
- Use the table to determine the minimum wire size (A.W.G.) extension cord.
- Use only 3-wire extension cords having 3-prong grounding type plugs and 3-pole receptacles which accept the tool plug.
- If the extension cord is worn, cut or damaged in any way, replace it immediately.

Extension Cord Table						
		Volts	Total Length of Cord in Feet			
Ampere Rating		120	25	50	100	150
More Than	Not More Than	240	50	100	150	300
		Minimum Gage for Cord				
0	6		18	16	16	14
6	10		18	16	14	12
10	12		16	16	14	12
12	16		14	12	Not Recommended	

**ELECTRICAL CONNECTIONS**

**WARNING:** All electrical connections must be performed by a qualified electrician. Make sure tool is off and disconnected from power source while motor is mounted, connected, reconnected or anytime wiring is inspected.

- Motor and wires are installed as shown in wiring diagram (See Figure 7). Motor is assembled with approved, 3-conductor cord to be used at 120/240 volts. Motor is prewired at the factory for 120 volts.

Sander has a locking rocker switch with removable key for safe and easy operation

- Remove the key from the locking rocker to prevent unauthorized use of the tool. To replace the key, press key into the slot on the locking rocker.
- To use the sander with a 240V power supply, have a qualified electrician rewire motor and attach a 240 volt three-prong plug onto sander line cord.

Sander also has a thermal overload protector to prevent damage to motor and other electrical components. The thermal overload protector will get activated when high temperature conditions are observed while operating the tool. This will turn the tool off to prevent temperature buildup. If that occurs, give adequate time for the sander to cool down and depress the reset button once. The tool will be ready to operate.

**OPERATION**

Refer to Figure 7.

**WARNING:** Operation of any power tool can result in foreign objects being thrown into eyes which can result in severe eye damage. Always wear safety goggles complying with United States ANSI Z87.1 (shown on package) before commencing power tool operation.

**CAUTION:** Always observe the following safety precautions:

- Whenever adjusting or replacing any parts on the tool, turn switch OFF and remove the plug from power source.
- Recheck table handles. They must be tightened securely.
- Make sure all guards are properly attached and securely fastened.
- Make sure all moving parts are free and clear of any interference.
- Make sure all fasteners are tight and have not vibrated loose.
- With power disconnected, test operation by hand to verify clearance and adjust if necessary.
- Always wear eye protection or face shield.
- Make sure abrasive belt tracks properly. Correct tracking gives optimum performance.
- After turning switch ON, always allow belt to come up to full speed before sanding or grinding.
- Be sure motor runs clockwise on disc side. Abrasive belt must travel down.
- Keep your hands clear of abrasive belt, disc and all moving parts.

**OPERATION (CONTINUED)**

- For optimum performance, do not stall motor or reduce speed. Do not force the work into the abrasive.
- Support workpiece with belt table when sanding with belt, with disc table when sanding with disc.
- Never push a sharp corner of workpiece rapidly against belt or disc. Abrasive backing may tear.
- Replace abrasives when they become loaded (glazed) or frayed.
- When grinding metal, move workpiece across abrasive to prevent heat build-up.
- Never attempt wet sanding. If workpiece becomes too hot to handle, cool it in water.

**POSITION BELT TABLE**

Refer to Figure 7.

The belt table can be tilted from 0° (at right angle to the table) to 45°. To adjust belt table position:

1. Unlock the handle on the right side of table.
2. Set the belt table to any angle between 0° and 45° using the scale.
2. Lock the handle to secure belt table position.

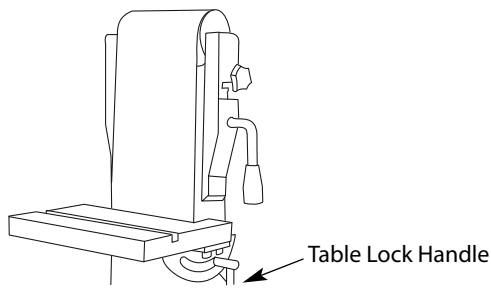

**Figure 7 - Attach belt table.**

**WORK STOP**

The work stop can be used instead of the belt table.

1. Remove belt table from the belt housing by loosening and removing handle.
2. Mount workstop using bolt and washer which are located on belt housing.

**ADJUSTING BELT HOUSING**

The belt housing can be positioned at a full vertical position, a full horizontal position, or at any angle in between which is convenient for the sanding operation.

To adjust belt housing position:

1. Loosen and remove four knobs.
2. Remove dust hoods.
3. Loosen hex nuts.
4. Move to the rear of the sander.
5. Gently push belt housing to move to the desired angle.
- A positive stop bolt is provided to stop the belt housing at the full horizontal position.
6. Tighten both hex nuts to secure belt housing position.
7. Replace dust hoods using the knobs.

**HORIZONTAL BELT SANDING**

Refer to Figure 8.

1. Adjust the belt housing to full horizontal position as described in the above section, "Adjusting Belt Housing".
  2. Remove the belt table by removing handle.
  3. Install work stop as described in "Work Stop".
- Idler drum can be used as a contact drum to sand curved surfaces. (Removing belt guard will be required.)

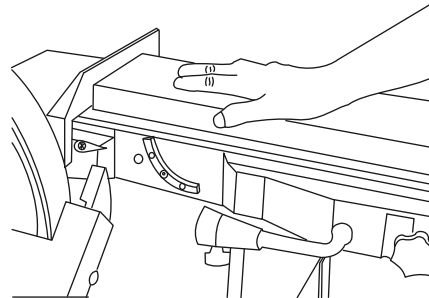

**Figure 8 - Horizontal belt sanding.**

**ABRASIVE BELT FINISHING**

- Finishing flat surfaces: Hold workpiece firmly with both hands; keep fingers away from abrasive belt.
- Use work stop. Work stop is used to position and secure work being sanded. Keep end butted against work stop and move work evenly across abrasive belt. Use extra caution when finishing very thin pieces.
- Finishing long pieces: remove work stop. Apply only enough pressure to allow abrasive belt to remove material.
- Finishing curved edges: Finish outside curves on flat portion of abrasive belt. Finish inside curves on idler drum portion of abrasive belt.
- Finishing end grain: It is more convenient to finish ends of long workpieces with the abrasive belt in a vertical position.
- Move work evenly across the belt.
- For accuracy use miter gauge.
- Adjust belt table angle for beveled work.

**USING MITER GAUGE**

- The miter gauge is used on either the disc or belt table. Use the miter gauge for securing the work and holding the proper angle while sanding.
- Adjust angle by repositioning the miter gauge. Loosen the knob to reposition miter gauge.
- Tighten the knob to secure miter gauge position.
- Miter gauge assembly has a positive stop set-up for 90° and 45° on either side.
- To use the positive stop, loosen the knob, retract the indexing pin, turn the miter gauge slightly, slide in indexing pin and turn the miter gauge until the edge of the screw is stopped by the indexing pin.
- Check accuracy of miter gauge scale.
- Use a combination square to adjust miter gauge square to disc. Scale should be at zero. Loosen screw and reposition scale if necessary.

**OPERATION (CONTINUED)****BELT TRACKING**

Belt should ride centered on drive and idler drums. The sander is shipped with the tracking mechanism properly adjusted. However, if adjustment is necessary:

1. Loosen knob on either side of belt housing.
2. Turn the unit on.
3. Insert a 1/8" or 5/32" hex wrench into the hole on adjusting nut on either side.
4. Turn the adjusting nut to the right to move belt toward you or turn the adjusting nut to the left to move belt away from you.
5. Make sure belt rides on the center of drive and idler drums.
6. Turn the unit off.
7. Tighten knobs on both sides of belt housing to secure tracking adjustment.

**REPLACING BELT**

Sanding belt must be replaced when worn, torn, or glazed.

1. Push up the belt tension handle to release belt tension.
  2. Loosen knob securing belt guard.
  3. Loosen and remove four knobs from the rear of the sander.
  4. Remove belt cover.
  5. Remove knob and bracket.
  6. Slide old belt off the drive and idler drums.
- NOTE:** There may be an arrow on the inside of the belt. The arrow should point down toward the belt table to ensure that the splice in the belt will not come apart.
7. Slide new belt over the drive and idler drums; center belt on drums.
  8. Push the belt tension handle toward the drive drum to tension belt.
  9. Replace belt cover using knobs.
  10. Replace belt guard and bracket.
  11. Wear a protective glove and manually rotate the belt by hand to check tracking. If tracking needs to be adjusted, follow steps described in "Belt Tracking".
  12. Make sure belt rides centered on drive and idler drums.

**POSITION DISC TABLE**

Disc table is adjustable from 0° to 45° outward and 0° to 20° inward.

1. To adjust the disc table position, loosen the two handles from either side of the disc table.
5. Use the scale on disc table trunnions to set table at the desired angle.
3. Secure disc table position by tightening the two handles.

**ABRASIVE DISC FINISHING**

- Abrasive disc sanding is well suited for finishing small flat surfaces and convex edges.
- Move workpiece across down side (left) of abrasive disc.
- Abrasive disc moves fastest and removes more material at outer edge.
- For accuracy, use miter gauge.

**REPLACING ABRASIVE DISC**

1. Loosen and remove four bolts from disc cover plate.
  2. Loosen two top bolts from dust collection port.
  3. Remove disc cover plate.
  4. Remove old abrasive by peeling it from the cast iron disc. Removing cast iron disc is not necessary.
  5. Clean cast iron disc if necessary. Select the proper abrasive disc and apply to cast iron disc.
- Additional abrasive discs are available.
6. Replace disc cover plate.
  7. Tighten bolts on dust collection port.
  8. Replace four bolts to secure disc cover plate.

**MAINTENANCE**

**WARNING:** Make certain that the unit is disconnected from power source before attempting to service or remove any component.

**CLEANING**

Keep machine and workshop clean. Do not allow sawdust to accumulate on the tool. Keep the drums clean. Dirt on drums will cause poor tracking and belt slippage. Operate tool with dust collector to keep dust from accumulating.

**WARNING:** After sanding wood or nonmetallic material, always clean dust collector and guards of sawdust before grinding metal. Sparks could ignite debris and cause a fire.

- Be certain motor is kept clean and is frequently vacuumed free of dust.
- Use soap and water to clean painted parts, rubber parts and plastic guards.

**LUBRICATION**

The shielded ball bearings in this tool are permanently lubricated at the factory. They require no further lubrication.

- When operation seems stiff, a light coat of paste wax applied to the belt and disc tables will make it easier to feed the work while finishing.
- Do not apply wax to the belt platen. Belt could pick up wax and deposit it on the drums causing belt to slip.

**KEEP TOOL IN REPAIR**

- If power cord is worn, cut, or damaged in any way, have it replaced immediately.
- Replace worn abrasives when needed.
- Replace any damaged or missing parts. Use parts list to order parts.

Any attempt to repair motor may create a hazard unless repair is done by a qualified service technician.

**ELECTRICAL DIAGRAMS**

**9681109  
Single Phase 115 V**

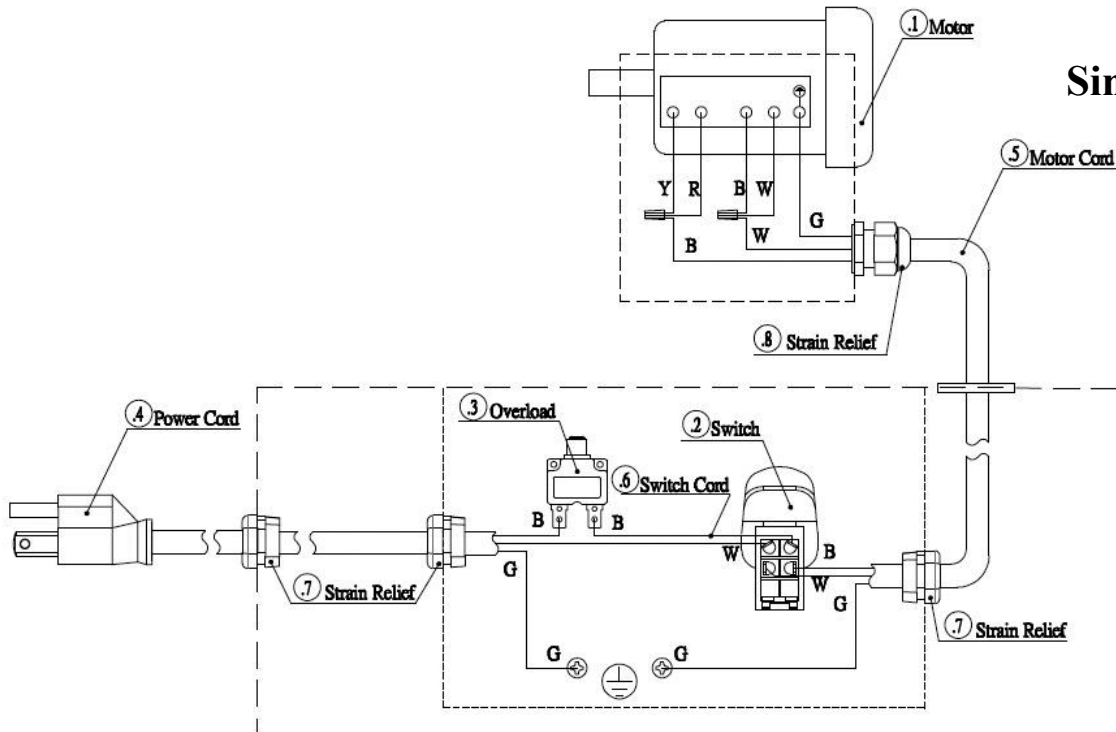

Figure 9 - 9681109 single phase 115 V electrical diagram.

**9681109  
Single Phase 230 V**

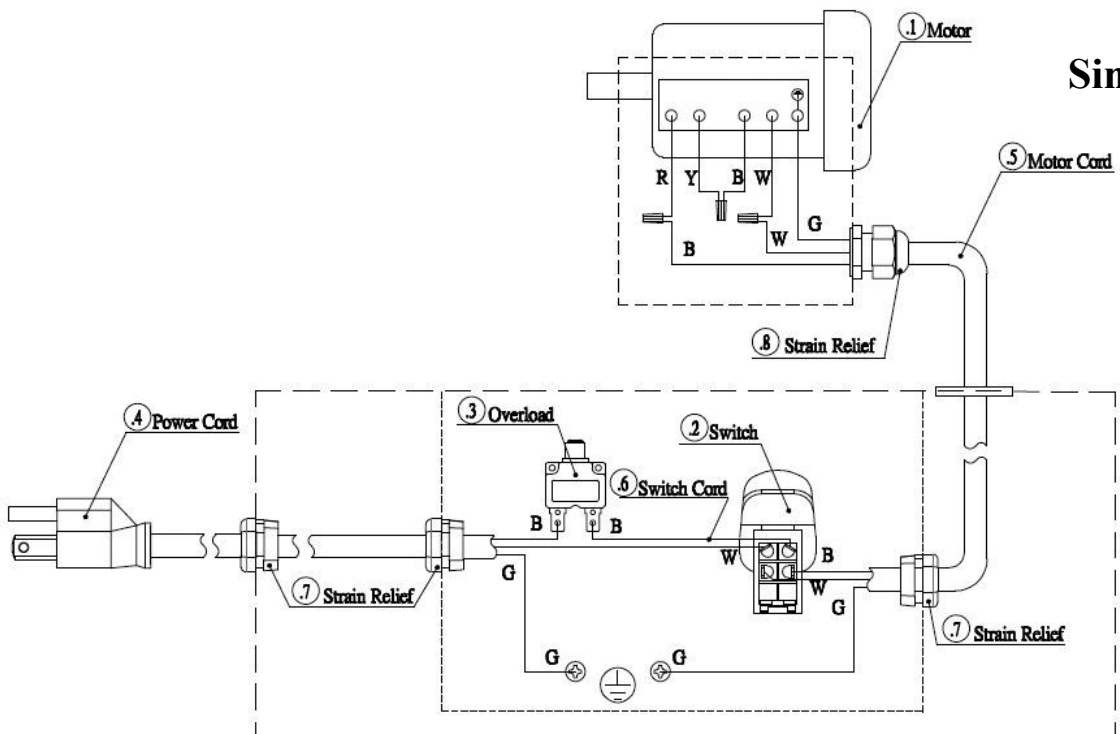
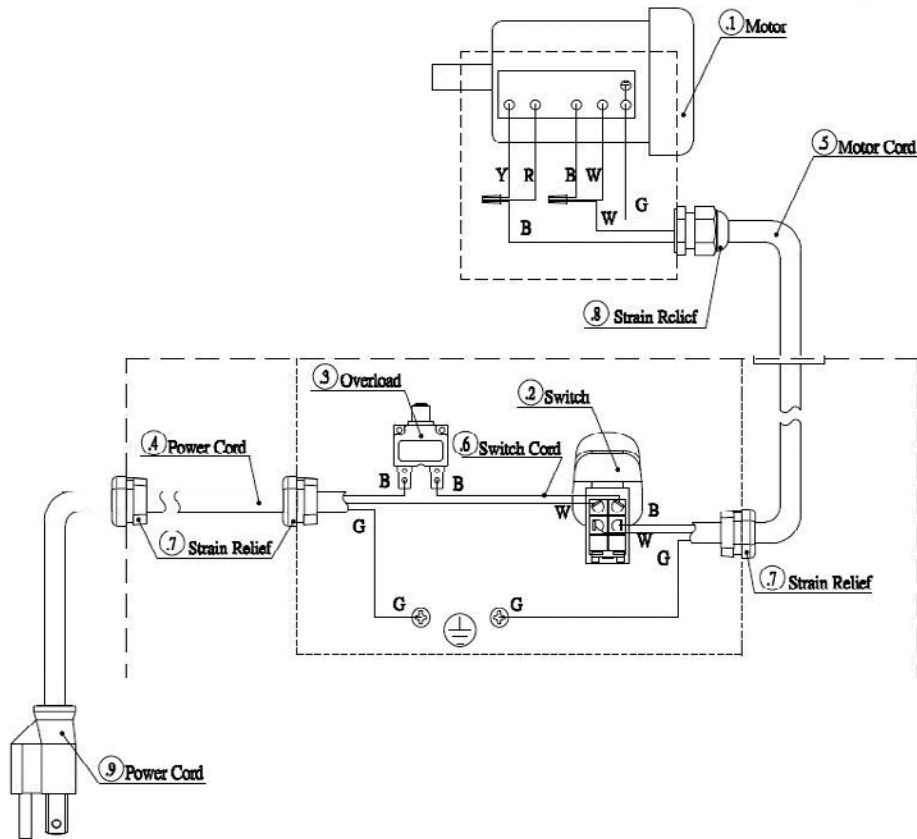

Figure 10 - 9681109 single phase 230 V electrical diagram.



**ELECTRICAL DIAGRAMS (CONTINUED)**

**9681108  
Single Phase 115V**



B = Black  
W = White  
G = Green  
R = Red  
Y = Yellow

Figure 11 - 9681108 single phase 115V electrical diagram.

**9681108  
Single Phase 230V**

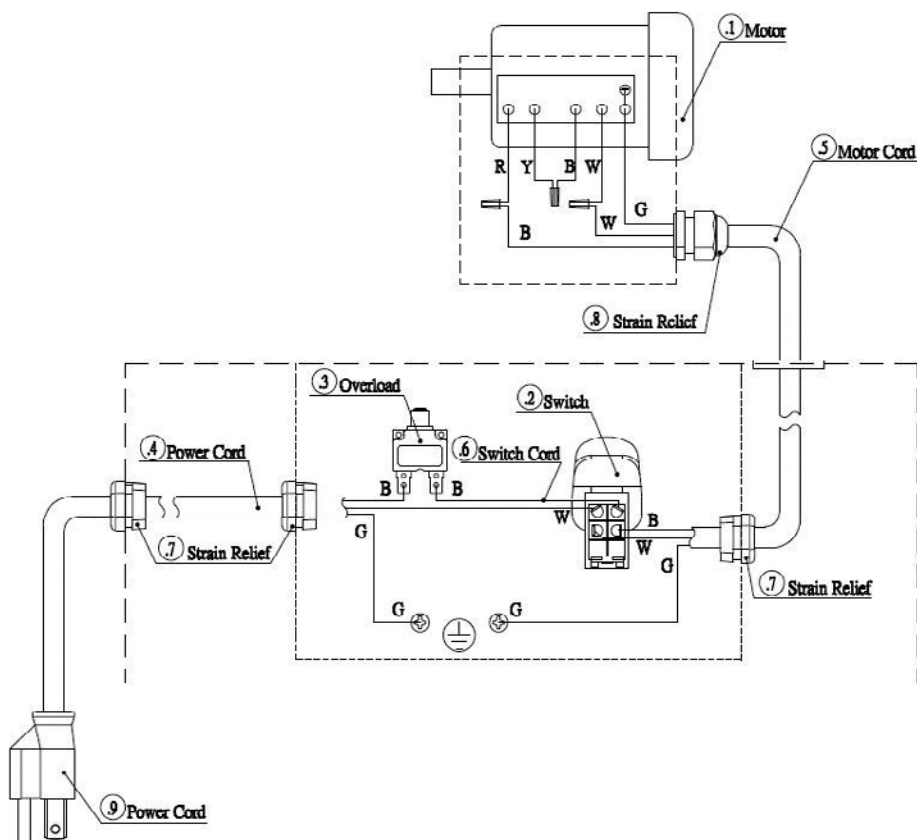

B = Black  
W = White  
G = Green  
R = Red  
Y = Yellow

Figure 12 - 9681108 single phase 230V electrical diagram.

## TROUBLESHOOTING

SYMPTOM	POSSIBLE CAUSE(S)	CORRECTIVE ACTION
Motor will not start	<ol style="list-style-type: none"> <li>1. Low voltage</li> <li>2. Open circuit in motor or loose connections</li> </ol>	<ol style="list-style-type: none"> <li>1. Check power line for proper voltage</li> <li>2. Inspect all lead connections on motor for loose or open connection</li> </ol>
Motor will not start; fuses blown or circuit breakers tripped	<ol style="list-style-type: none"> <li>1. Short circuit in line cord or plug</li> <li>2. Short circuit in motor or loose connections</li> <li>3. Incorrect fuses or circuit breakers in power line</li> </ol>	<ol style="list-style-type: none"> <li>1. Inspect line cord or plug for damaged insulation and shorted wires</li> <li>2. Inspect all lead connections on motor for loose or shorted terminals or worn insulation on wires.</li> <li>3. Install correct fuses or circuit breakers</li> </ol>
Motor fails to develop full power (power output of motor decreases rapidly with decrease in voltage at motor terminals)	<ol style="list-style-type: none"> <li>1. Power line overloaded with lights, appliances and other motors</li> <li>2. Undersized wires or circuits too long</li> <li>3. General overloading of power company's facilities</li> </ol>	<ol style="list-style-type: none"> <li>1. Reduce load on power line</li> <li>2. Increase wire sizes, or reduce length of wiring</li> <li>3. Request a voltage check from power company</li> </ol>
Motor overheats	Motor overloaded	Reduce load on motor.
Motor stalls (resulting in blown fuses or tripped circuit breakers)	<ol style="list-style-type: none"> <li>1. Short circuit in motor or loose connections</li> <li>2. Low voltage</li> <li>3. Incorrect fuses or circuit breakers in power line</li> <li>4. Motor overloaded</li> </ol>	<ol style="list-style-type: none"> <li>1. Inspect connections in motor for loose or shorted terminals or worn insulation on lead wires</li> <li>2. Correct the low line voltage conditions</li> <li>3. Install correct fuses or circuit breakers</li> <li>4. Reduce load on motor</li> </ol>
Machine slows down while operating	Applying too much pressure to workpiece	Ease up on pressure
Abrasive belt runs off top wheel	Not tracking properly	See operation "Belt Tracking"



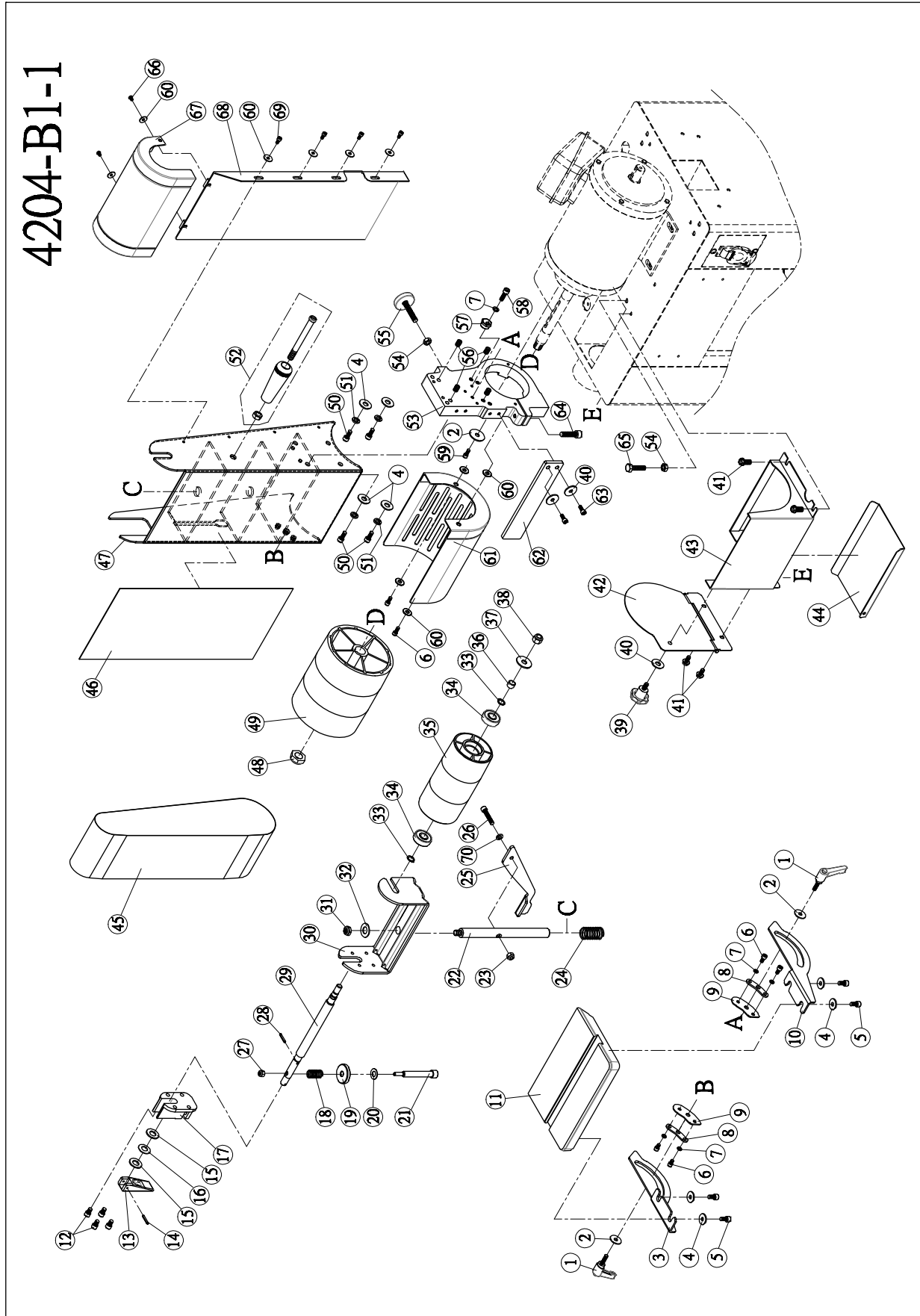

Figure 13 – Repair Parts Illustration for 9681109 Belt

**REPAIR PARTS LIST FOR 9681109 BELT**

Ref. No.	Description	Part No.	Qty	Ref. No.	Description	Part No.	Qty.
1	Universal Handle M6*1.0P*20L	50114028	2	36	Bushing	42011048	1
2	Flat Washer 1/4"*25*2t	*	3	37	Flat Washer 10*22*2t	*	1
3	Belt Table Support - Left	42031017	1	38	Nylon Nut 3/8"-16UNC (7t)	*	1
4	Flat Washer 8.5*20*1.5t	*	8	39	Knub M6*1.0P*15L	50111025	1
5	Cap Screw M8*1.25P*12L	*	4	40	Flat Washer 6.5*19*2t	*	3
6	Cap Screw M5*0.8P*12L	*	6	41	Hex. Screw M6*1.0P*12L	*	4
7	Spring Washer M5	*	5	42	Drive Drum Cover	42031022	1
8	Trunnion	42031020	2	43	Dust Chute	42031021	1
9	Trunnion Plate	42031005	2	44	Air Controller	42031018	1
10	Belt Table Support - Right	42031016	1	45	Sanding Belt TR332#100	9600511.00	1
11	Belt Table	42031015	1	46	Graphite Pad	42011057	1
12	Cap Screw 1/4"-20UNC*3/8"L	*	4	47	Belt Support	42031028	1
13	Lock Handle	42011044	1	48	Nylon Nut	*	1
14	Roll Pin 3*20L	*	1	49	Drive Drum	42011027	1
15	Flat Washer 12*23*2t	*	2	50	Cap Screw M8*1.25P*16L	*	4
16	Disc Spring	42011043	1	51	Spring Washer M8	*	4
17	Micro-Adjusting Seat	42011039	1	52	Handwheel Handle	34013101	1
18	Spring	42011041	1	53	Bracket	42031023	1
19	Adjusting Knob	42011042	1	54	Hex. Nut M8*1.25P	*	2
20	Flat Washer 3/8"*19*1t	50351073	1	55	Leveling Pad	31041023	1
21	Screw	*	1	56	Set Screw M8*1.25P*10L	*	4
22	Shaft of Support Bracket	42011073	1	57	Eccentric Bottom Bracket	42031004	1
23	Nylon Nut 1/4"-20UNC	50252023	1	58	Cap Screw M5*0.8P*18L	*	1
24	Spring	42011037	1	59	Cap Screw M6*1.0P*12L	*	1
25	Eccentric Handle	42011038	1	60	Flat Washer 5.2*16*1t	*	10
26	Cap Screw 1/4"-20UNC*1 1/4"L	*	1	61	Safety Guard	42031007	1
27	Nylon Nut M6*1.0P	*	1	62	Stop Plate	42031019	1
28	Roll Pin 4*20L	*	1	63	Cap Screw M6*1.0P*16L	*	2
29	Shaft	42011046	1	64	Cap Screw M8*1.25P*30L	*	1
30	Support Bracket	42011036	1	65	Hex. Screw M8*1.25P*45L	*	1
31	Nylon Nut 3/8"-24UNF (7t)	*	1	66	Round Head Screw M5*0.8P*8L	*	2
32	Flat Washer 10.5*16*1.5	*	1	67	Upper Cover	42031006	1
33	C-Ring STW-11	*	2	68	Back Cover	42031025	1
34	Ball Bearing G201-2RS-	*	2	69	Cap Screw M5*0.8P*8L	*	4
35	Follow Roller	42011045	1	70	Spring Washer 1/4"	*	1

(Δ) Not shown.

(N/A) Not available as repair part.

(\*) Standard hardware item, available locally.

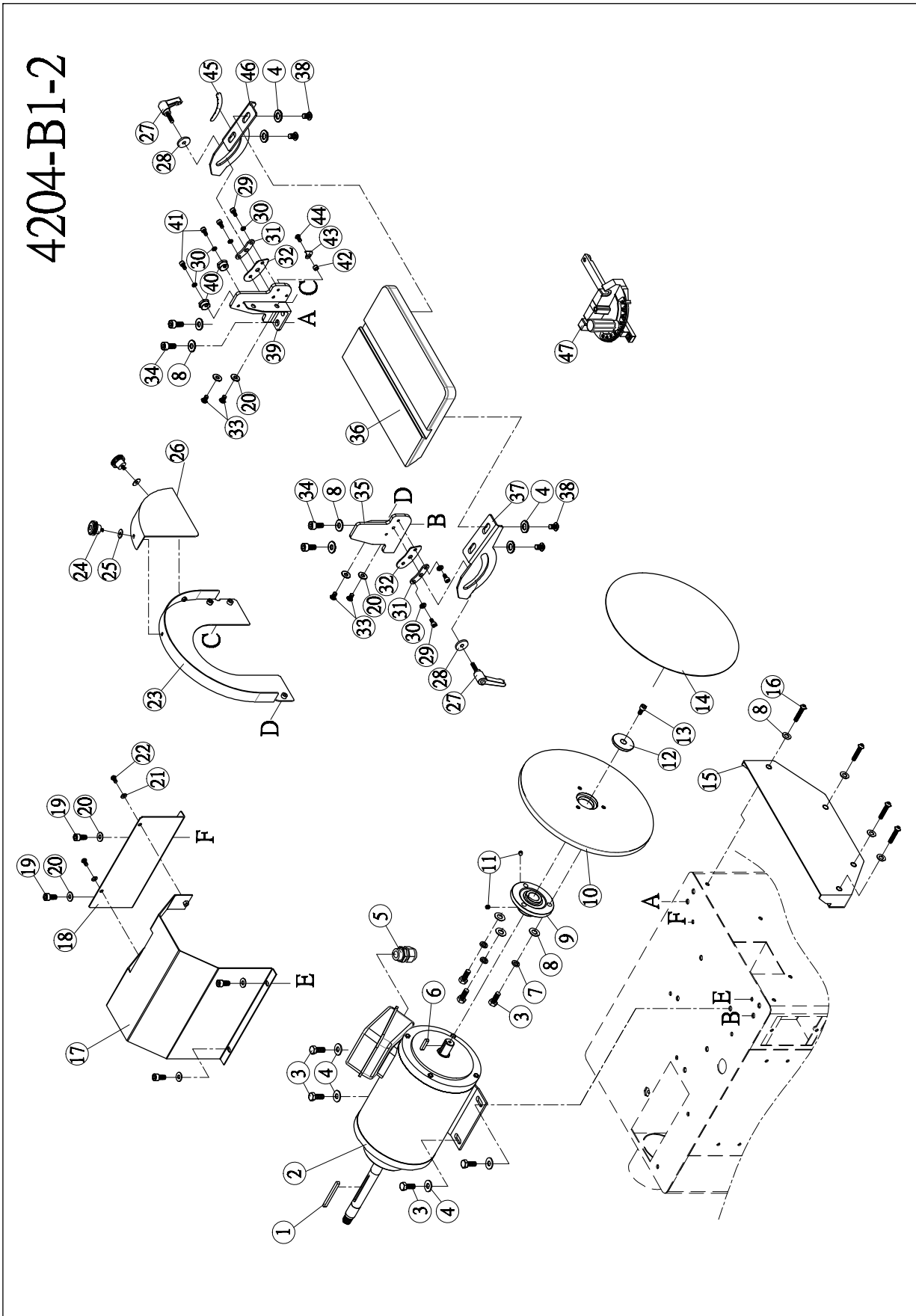

Figure 14 – Repair Parts Illustration for 9681109 Disc

**REPAIR PARTS LIST FOR 9681109 DISC**

Ref. No.	Description	Part No.	Qty	Ref. No.	Description	Part No.	Qty.
1	Key 5*5*70L	50604026	1	25	Flat Washer 5.2*16*1t	*	2
2	Motor	42031501	1	26	Front Disc Guard	42031036	1
3	Hex. Screw M8*1.25P*20L	*	7	27	Universal handle M6*1.0P*20L	50114028	2
4	Flat Washer 8.5*20*1.5t	50301091	8	28	Flat Washer 1/4"*25*2t	*	2
5	Strain Relief PG 13.5	51104008	1	29	Cap Screw M5*0.8P*12L	*	4
6	Key 5*5*25L	50604010	1	30	Spring Washer M5	*	6
7	Spring Washer M8	*	3	31	Trunnion	42031020	2
8	Flat Washer 8.5*16*1.5t	*	9	32	Trunnion Plate	42031005	2
9	Flange	42031011	1	33	Round Head Hex Screw M6*1.0P*12L	*	8
10	10" Disc	42031010	1	34	Cap Screw M8*1.25P*16L	*	4
11	Set Screw M8*1.25P*6L	*	2	35	Guard Fixed Seat - Left	42031026	1
12	Clamp Block	42031030	1	36	Disc Table	42031001	1
13	Cap Screw M6*1.0P*14L	*	1	37	Disc Table Support - Left	42031003	1
14	10" Sanding Disc TJ32#80	9636134.00	1	38	Round Head Screw M8*1.25P*12L	*	4
15	End Cover	42031009	1	39	Guard Fixed Seat - Right	42031027	1
16	Round Head Hex Screw M8*1.25P*45L	*	2	40	Eccentric Bottom Bracket	42031004	2
17	Front Motor Guard	42031033	1	41	Cap Screw M5*0.8P*18L	*	2
18	Rear Motor Guard	42031034	1	42	Bushing	42031032	1
19	Cap Screw M6*1.0P*12L	*	4	43	Point	42031012	1
20	Flat Washer 6*12*1t	*	8	44	Round Head Screw M5*0.8P*12L	*	1
21	Flat Washer 5.1*12*1t	*	2	45	Angle Label	42031013	1
22	Round Head Screw M5*0.8P*10L	*	2	46	Disc Table Support - Right	42031002	1
23	Disc Guard	42031014	1	47	Miter Gauge	42011201	1
24	Lock Knob M5*0.8P*7L	50111019	2				

(Δ) Not shown.

(N/A) Not available as repair part.

(\*) Standard hardware item, available locally.

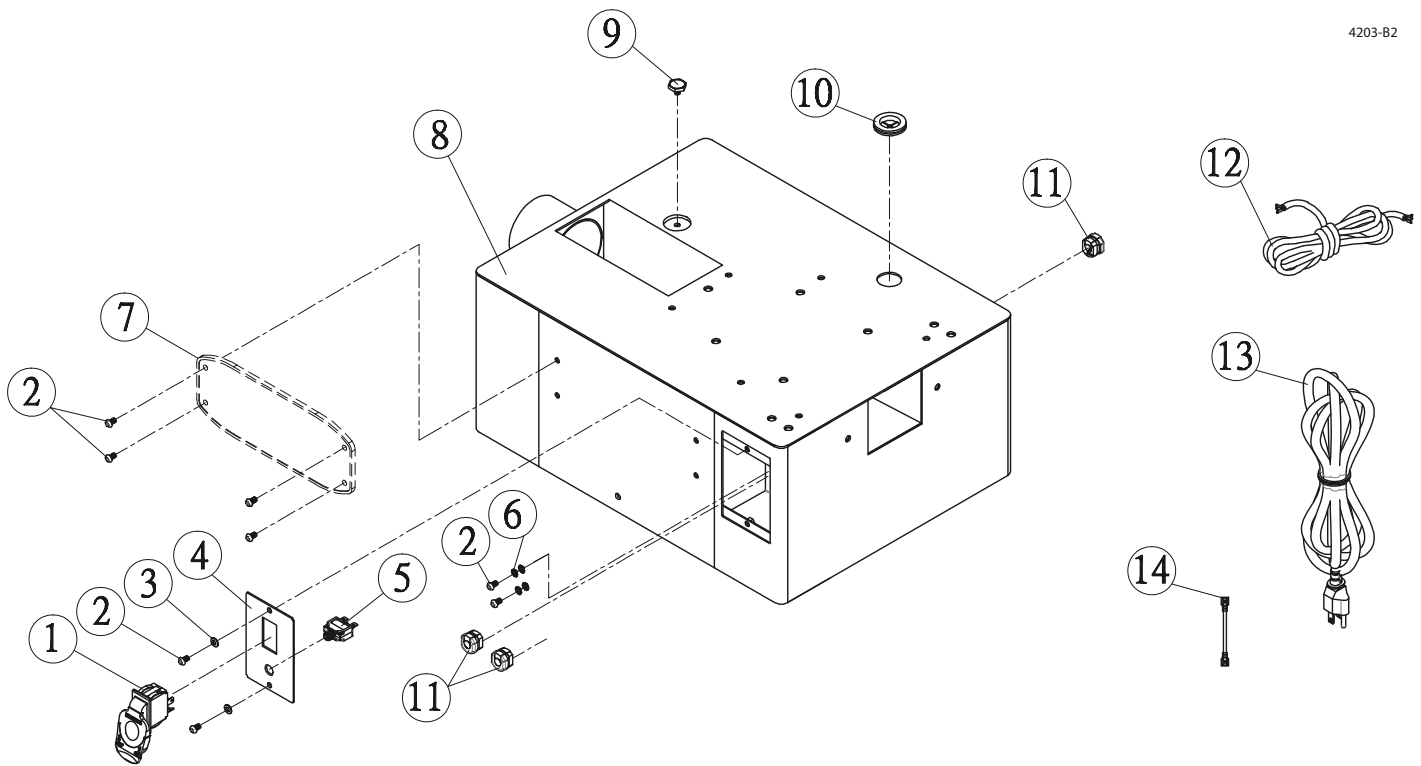

Figure 15 – Replacement Parts Illustration for 9681109 Base

## REPLACEMENT PARTS LIST FOR 9681109 BASE

Ref. No.	Description	Part Number	Qty.
1	Switch	42011601	1
2	Round Head Screw M5*0.8P*10L	*	8
3	Flat Washer 5.1*12*1t	*	2
4	Switch Plate	42031024	1
5	Overload 125V/250V 12A	42031601	1
6	Tooth Washer M5	*	4
7	ID Label	38100305	1
8	Base	42031008	1
9	Magnet	18061018	1
10	Rubber Plug	34011029	1
11	Strain Relief	51101003	3
12	Motor Cord	42031701	1
13	Power Cord	42031801	1
14	Switch Cord	37071901	1

(Δ) Not shown.

(N/A) Not available as repair part.

(\*) Standard hardware item, available locally.



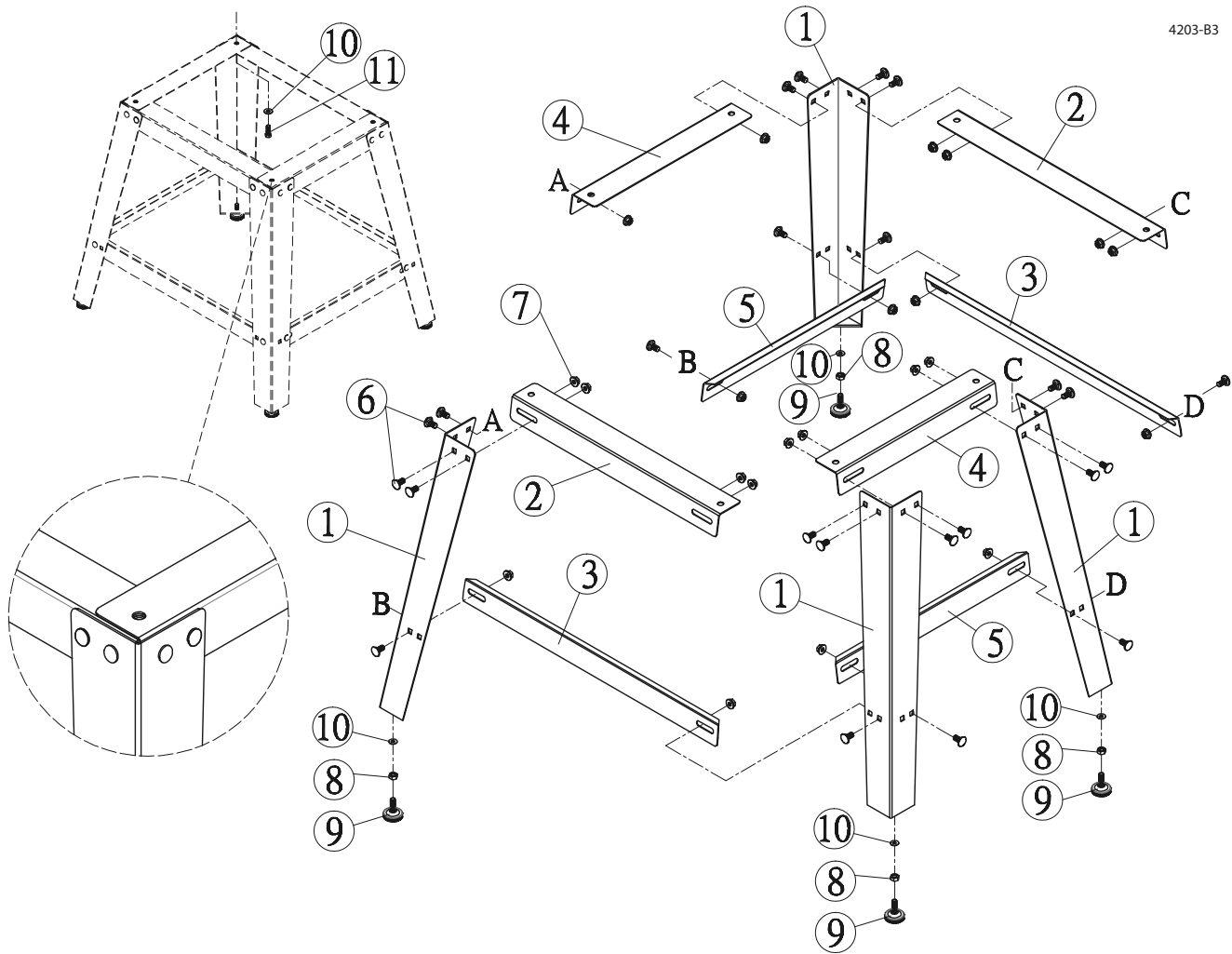

Figure 16 – Replacement Parts Illustration for 9681109 Stand

**REPLACEMENT PARTS LIST FOR 9681109 STAND**

Ref. No.	Description	Part Number	Qty.
1	Stand Leg	42033001	4
2	Stand Top - Long	42033002	2
3	Long Rail	42033005	2
4	Stand Top - Short	42033003	2
5	Short Rail	42033004	2
6	Carriage Bolt 5/16"-18UNC*1/2"L(7.9*1.7)	*	24
7	Lock Nut w/Flange 5/16"-18UNC	*	24
8	Hex. Nut M8*1.25P	*	4
9	Leveling Pad	31041023	4
10	Flat Washer 8.5*20*1.5t	*	8
11	Hex. Screw M8*1.25P*16L	*	4

(Δ) Not shown.  
 (N/A) Not available as repair part.  
 (\*) Standard hardware item, available locally.

# 4203-B1-1

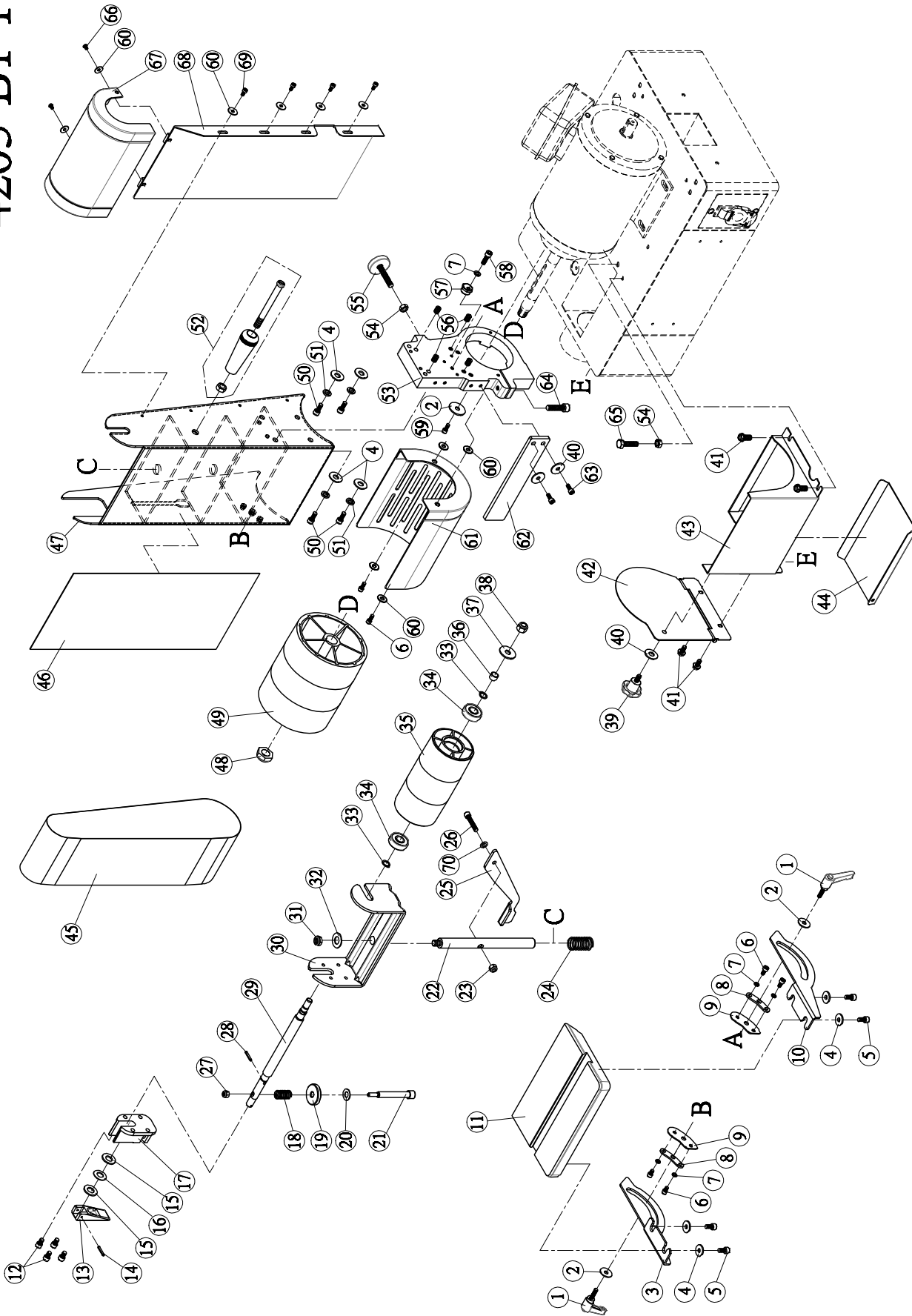

Figure 17 – Repair Parts Illustration for 9681108 Belt

**REPAIR PARTS LIST FOR 9681108 BELT**

Ref. No.	Description	Part No.	Qty	Ref. No.	Description	Part No.	Qty.
1	Universal Handle M6*1.0P*20L	50114028	2	36	Bushing	42011048	1
2	Flat Washer 1/4"*25*2t	*	3	37	Flat Washer 10*22*2t	*	1
3	Belt Table Support - Left	42031017	1	38	Nylon Nut 3/8"-16UNC (7t)	*	1
4	Flat Washer 8.5*20*1.5t	*	8	39	Knub M6*1.0P*15L	50111025	1
5	Cap Screw M8*1.25P*12L	*	4	40	Flat Washer 6.5*19*2t	*	3
6	Cap Screw M5*0.8P*12L	*	6	41	Hex. Screw M6*1.0P*12L	*	4
7	Spring Washer M5	*	5	42	Drive Drum Cover	42031022	1
8	Trunnion	42031020	2	43	Dust Chute	42031021	1
9	Trunnion Plate	42031005	2	44	Air Controller	42031018	1
10	Belt Table Support - Right	42031016	1	45	Sanding Belt TR332#100	42031031	1
11	Belt Table	42031015	1	46	Graphite Pad	42011057	1
12	Cap Screw 1/4"-20UNC*3/8"L	*	4	47	Belt Support	42031028	1
13	Lock Handle	42011044	1	48	Nylon Nut	*	1
14	Roll Pin 3*20L	*	1	49	Drive Drum	42011027	1
15	Flat Washer 12*23*2t	*	2	50	Cap Screw M8*1.25P*16L	*	4
16	Disc Spring	42011043	1	51	Spring Washer M8	*	4
17	Micro-Adjusting Seat	42011039	1	52	Handwheel Handle	34013101	1
18	Spring	42011041	1	53	Bracket	42031023	1
19	Adjusting Knob	42011042	1	54	Hex. Nut M8*1.25P	*	2
20	Flat Washer 3/8"*19*1t	*	1	55	Leveling Pad	31041023	1
21	Screw	*	1	56	Set Screw M8*1.25P*10L	*	4
22	Shaft of Support Bracket	42011073	1	57	Eccentric Bottom Bracket	42031004	1
23	Nylon Nut 1/4"-20UNC	*	1	58	Cap Screw M5*0.8P*18L	*	1
24	Spring	42011037	1	59	Cap Screw M6*1.0P*12L	*	1
25	Eccentric Handle	42011038	1	60	Flat Washer 5.2*16*1t	*	10
26	Cap Screw 1/4"-20UNC*1 1/4"L	*	1	61	Safety Guard	42031007	1
27	Nylon Nut M6*1.0P	*	1	62	Stop Plate	42031019	1
28	Roll Pin 4*20L	*	1	63	Cap Screw M6*1.0P*16L	*	2
29	Shaft	42011046	1	64	Cap Screw M8*1.25P*30L	*	1
30	Support Bracket	42011036	1	65	Hex. Screw M8*1.25P*45L	*	1
31	Nylon Nut 3/8"-24UNF (7t)	*	1	66	Round Head Screw M5*0.8P*8L	*	2
32	Flat Washer 10.5*16*1.5	*	1	67	Upper Cover	42031006	1
33	C-Ring STW-11	*	2	68	Back Cover	42031025	1
34	Ball Bearing G201-2RS	50501009	2	69	Cap Screw M5*0.8P*8L	*	4
35	Follow Roller	42011045	1	70	Spring Washer 1/4"	*	1

(Δ) Not shown.

(N/A) Not available as repair part.

(\*) Standard hardware item, available locally.

# 4203-B1-2

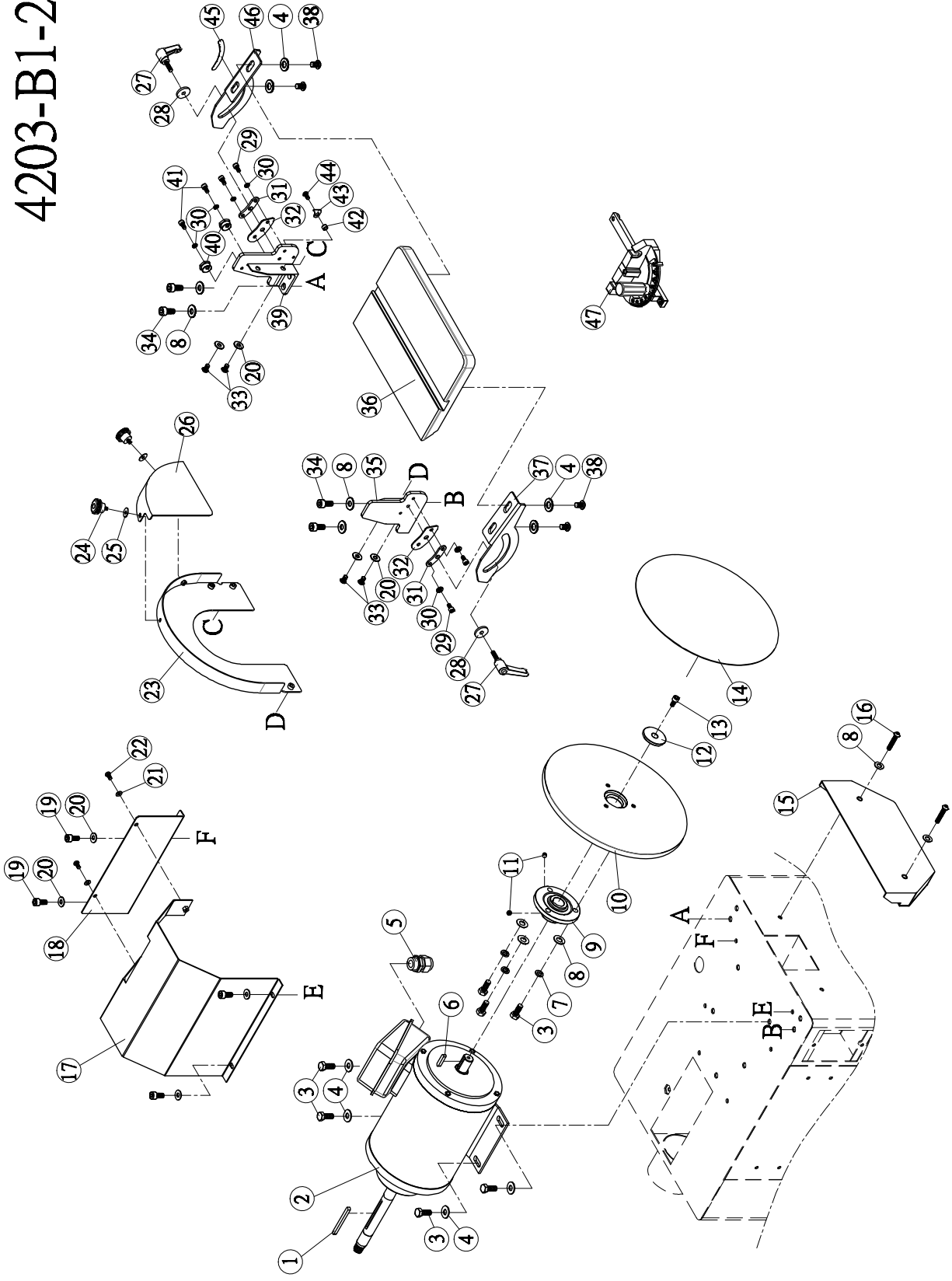

Figure 18 – Repair Parts Illustration for 9681108 Disc

**REPAIR PARTS LIST FOR 9681108 DISC**

Ref. No.	Description	Part No.	Qty	Ref. No.	Description	Part No.	Qty.
1	Key 5*5*70L	50604026	1	25	Flat Washer 5.2*16*1t	*	2
2	Motor	42041501	1	26	Front Disc Guard	42041011	1
3	Hex. Screw M8*1.25P*20L	*	7	27	Universal handle M6*1.0P*20L	50114028	2
4	Flat Washer 8.5*20*1.5t	50301091	4	28	Flat Washer 1/4"*25*2t	*	2
5	Strain Relief PG 13.5	51104008	1	29	Cap Screw M5*0.8P*12L	*	4
6	Key 5*5*25L	50604010	1	30	Spring Washer M5	*	6
7	Spring Washer M8	*	3	31	Trunnion	42031020	2
8	Flat Washer 8.5*16*1.5t	*	11	32	Trunnion Plate	42031005	2
9	Flange	42031011	1	33	Round Head Hex Screw M6*1.0P*12L	*	8
10	14" Disc	42041009	1	34	Cap Screw M8*1.25P*16L	*	4
11	Set Screw M8*1.25P*6L	*	2	35	Guard Fixed Seat - Left	42031026	1
12	Clamp Block	42031030	1	36	Disc Table 14"	42041001	1
13	Cap Screw M6*1.0P*14L	*	1	37	Disc Table Support - Left	42031003	1
14	14" Sanding Disc TJ-32 # 80	42041005	1	38	Flat Washer 6.5*19*2t	*	4
15	End Cover	42041003	1	39	Guard Fixed Seat - Right	42031027	1
16	Round Head Hex Screw M8*1.25P*45L	*	4	40	Eccentric Bottom Bracket	42031004	2
17	Front Motor Guard	42041006	1	41	Cap Screw M5*0.8P*18L	*	2
18	Rear Motor Guard	42041007	1	42	Bushing	42031032	1
19	Cap Screw M6*1.0P*12L	*	4	43	Point	42031012	1
20	Flat Washer 6*12*1t	*	8	44	Round Head Screw M5*0.8P*12L	*	1
21	Flat Washer 5.1*12*1t	*	2	45	Angle Label	42031013	1
22	Round Head Screw M5*0.8P*10L	*	2	46	Disc Table Support - Right	42031002	1
23	Disc Guard	42041010	1	47	Miter Gauge	42011201	1
24	Lock Knob M5*0.8P*7L	50111019	2				

(Δ) Not shown.

(N/A) Not available as repair part.

(\*) Standard hardware item, available locally.

4204-B2

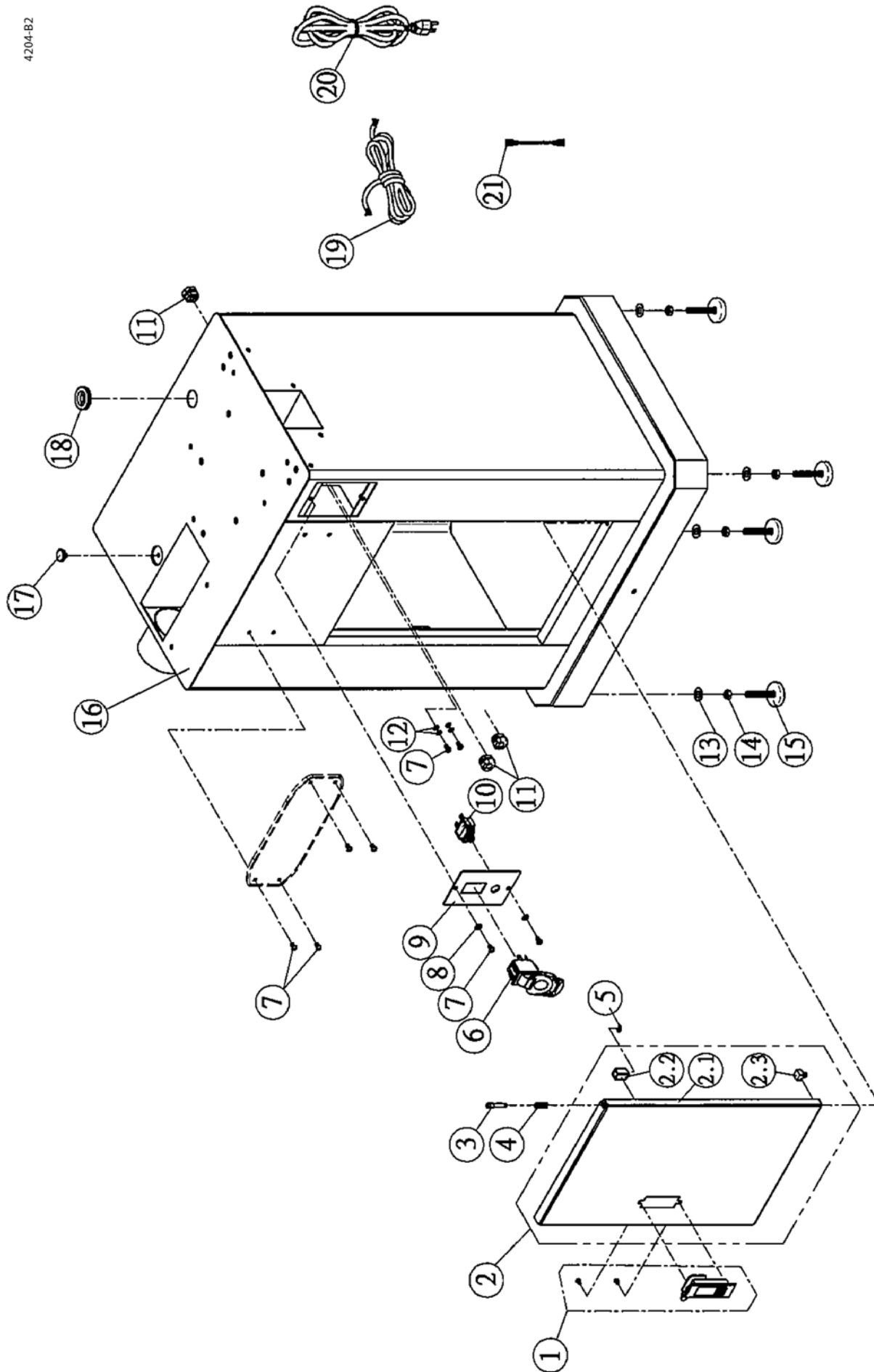

Figure 19 – Repair Parts Illustration for 9681108 Base

**REPAIR PARTS LIST FOR 9681108 BASE**

Ref. No.	Description	Part No.	Qty	Ref. No.	Description	Part No.	Qty.
1	Latch	42041004	1	14	Hex. Nut M8*1.25P	*	4
2	Door	42041101	1	15	Leveling Pad	31041023	4
3	Door Pivot	35022022	1	16	Base	42041008	1
4	Spring	35022028	1	17	Magnet	18061018	1
5	E-Clip ETW-4	*	1	18	Rubber Plug	34011029	1
6	Switch	42011601	1	19	Junction Box	81031020	1
7	Round Head Screw M5*0.8P*12L	*	8	20	Round Head Screw M5*0.8P*10L	50104014	4
8	Flat Washer 5.1*12*1t	*	2	21	Strain Relief PG 13.5	51104008	1
9	Switch Plate	42031024	1	22	Motor Cord	42041701	1
10	Overload 125V/250V 18A	42041601	1	23	Wire Cord Switch to Junction Box	42041702	1
11	Strain Relief	51101007	3	24	Switch Cord	42041901	1
12	Tooth Washer M5	*	4	25	Screw-on Wire Connector SW-P4H	51119002	2
13	Flat Washer 8.5*20*1.5t	*	4	26	ID Label	38100305	1

(Δ) Not shown.  
 (N/A) Not available as repair part.  
 (\*) Standard hardware item, available locally.

## PALMGREN WARRANTY

C.H. Hanson / Palmgren warrants their products to be free of defects in material or workmanship. This warranty does not cover defects due directly or indirectly to misuse, abuse, normal wear and tear, failure to properly maintain the product, heated, ground or otherwise altered, or used for a purpose other than that for which it was intended.

The warranty does not cover expendable and/or wear part (i.e. v-belts, screws, abrasives, jaws), damage to tools arising from alteration, abuse or use other than their intended purpose, packing and freight. The duration of this warranty is expressly limited to the terms noted below beginning from the date of delivery to the original user.

**The Palmgren branded items carry the following warranties on parts:**

**All vises, clamps, positioning tables, tombstones, jack screws and vise accessories - LIFETIME.**

**All bench grinders, drill presses, tapping machines, band saws, lathes, milling machines, arbor presses, abrasive finishing machines and work stands - 3 YEARS.**

The obligation of C.H. Hanson / Palmgren is limited solely to the repair or replacement, at our option, at its factory or authorized repair agent of any part that should prove inoperable. Purchaser must lubricate and maintain the product under normal operating conditions at all times. Prior to operation become familiar with product and the included materials, i.e. warnings, cautions and manuals.

**Failure to follow these instructions will void the warranty.**

This warranty is the purchaser's exclusive remedy against C.H. Hanson for any inoperable parts in its product. Under no circumstances is C.H. Hanson liable for any direct, indirect, incidental, special or consequential damages including loss of profits in any way related to the use or inability to use our products. This warranty gives you specific legal rights which may vary from state to state.

**PALMGREN**<sup>®</sup>

**Palmgren - a C.H. Hanson Company**  
**2000 N. Aurora Rd., Naperville, IL 60563 U.S.A.**  
**or call 1-800-827-3398**