

Installation and Care Guide  
Guide d'installation et d'entretien  
Guía de instalación y cuidado

Grab Bars  
Barres d'appui  
Agarraderas

K-11870, K-11871, K-11872,  
K-11873, K-11874, K-11875,  
K-11876, K-11877, K-11880,  
K-11881, K-11882, K-11883,  
K-11884, K-11885, K-11886,  
K-11887, K-11890, K-11891,  
K-11892, K-11893, K-11894,  
K-11895, K-11896, K-11897

M product numbers are for Mexico (i.e. K-12345M)  
Los números de productos seguidos de M  
corresponden a México (Ej. K-12345M)

USA/Canada: 1-800-4KOHLER

México: 001-800-456-4537

[kohler.com](http://kohler.com)

THE BOLD LOOK  
OF **KOHLER**®

1097577-2-C

©2013 Kohler Co.

## Tools/Outils/Herramientas

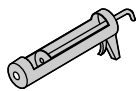

Caulk Gun  
Pistolet à mastic  
Pistola para calafatear

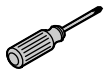

Phillips Screwdriver  
Tournevis cruciforme  
Destornillador Phillips

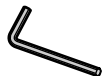

Hex Wrench  
Clé hexagonale  
Llave hexagonal

### Plus/Plus/Más:

- Silicone Sealant  
Joint silicone  
Sellador de silicona
- Stud Finder  
Repéreur de montant  
Localizador de postes de madera
- Bracing  
Renfort  
Refuerzo

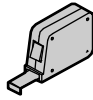
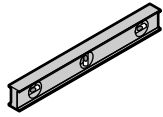

## Important Information



**CAUTION: Risk of personal injury.** The wall plates on the grab bar must be mounted to a brace between the wall studs. Doing so will ensure that the weight of the user is adequately supported.



**CAUTION: Risk of property damage.** For installation to ceramic tile: Apply silicone sealant into the drilled holes before securing the wall plates to the finished surface. This will reduce the risk of water damage behind the finished surface.



**CAUTION: Risk of property damage.** For installation to ceramic tile: Apply light, even pressure to avoid cracking the tile. Use a 3/16" or #12 drill bit to drill through the tile. Do not drill into the bracing.

- Observe all local plumbing codes and building codes.
- Before installing finished wall material, install bracing between the wall studs where the wall plates will be mounted.
- The appearance of your product may differ from the illustration. The installation instructions still apply.
- For all except K-1187 series:** this product is considered ADA compliant when located and mounted into a structural support per the ADA 2010 Standards for Accessible Design. Refer to the ADA Standards before installing this product.

## Informations importantes



**ATTENTION: Risque de blessures.** Les plaques murales sur la barre d'appui doivent être montées sur une entretoise entre les poteaux muraux afin d'assurer un support adéquat du poids de l'utilisateur.



**ATTENTION: Risque de dommages matériels.** Pour une installation sur du carrelage: Appliquer du mastic d'étanchéité à la silicone dans les trous percés avant de sécuriser les plaques murales à la surface finie. Ceci réduit le risque de dégâts d'eau derrière la surface finie.



**ATTENTION: Risque de dommages matériels.** Pour une installation sur du carrelage: Appliquer une pression légère pour éviter de fissurer le carreau. Utiliser une mèche de 3/16" ou n° 12 pour percer le carreau. Ne pas percer dans le renfort.

- Respecter tous les codes de plomberie et de bâtiment locaux.

# Roughing-In/Plan de raccordement/Diagrama de instalación

**K-11880** = 11-9/16" (294 mm)  
**K-11881** = 14-9/16" (370 mm)  
**K-11882** = 20-9/16" (522 mm)  
**K-11883** = 26-9/16" (675 mm)  
**K-11884** = 34-9/16" (878 mm)  
**K-11885** = 38-9/16" (979 mm)  
**K-11886** = 44-9/16" (1132 mm)  
**K-11887** = 50-9/16" (1284 mm)

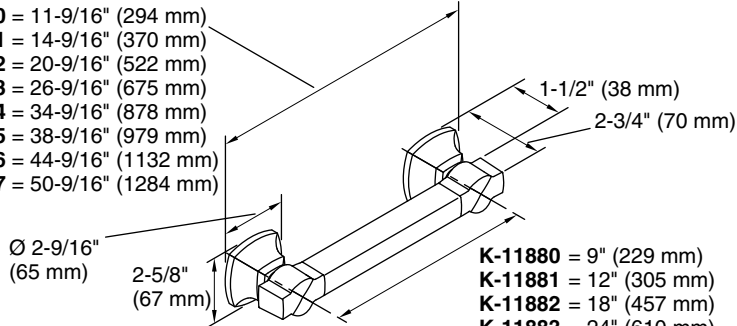

**K-11870** = 11-9/16" (294 mm)  
**K-11871** = 14-9/16" (370 mm)  
**K-11872** = 20-9/16" (522 mm)  
**K-11873** = 26-9/16" (675 mm)  
**K-11874** = 34-9/16" (878 mm)  
**K-11875** = 38-9/16" (979 mm)  
**K-11876** = 44-9/16" (1132 mm)  
**K-11877** = 50-9/16" (1284 mm)

**K-11880** = 9" (229 mm)  
**K-11881** = 12" (305 mm)  
**K-11882** = 18" (457 mm)  
**K-11883** = 24" (610 mm)  
**K-11884** = 32" (813 mm)  
**K-11885** = 36" (914 mm)  
**K-11886** = 42" (1067 mm)  
**K-11887** = 48" (1219 mm)

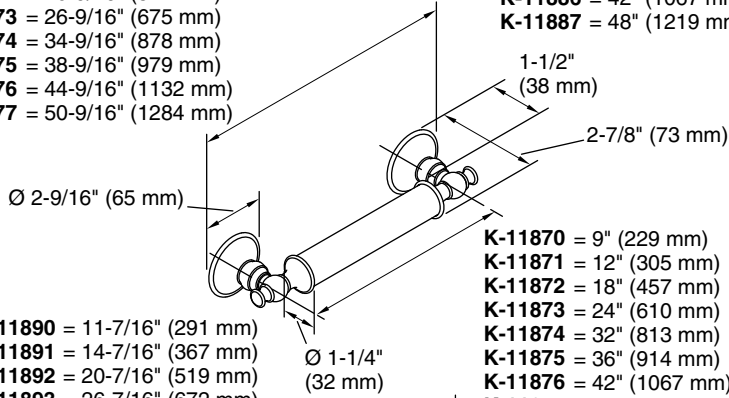

**K-11870** = 9" (229 mm)  
**K-11871** = 12" (305 mm)  
**K-11872** = 18" (457 mm)  
**K-11873** = 24" (610 mm)  
**K-11874** = 32" (813 mm)  
**K-11875** = 36" (914 mm)  
**K-11876** = 42" (1067 mm)  
**K-11877** = 48" (1219 mm)

**K-11890** = 11-7/16" (291 mm)  
**K-11891** = 14-7/16" (367 mm)  
**K-11892** = 20-7/16" (519 mm)  
**K-11893** = 26-7/16" (672 mm)  
**K-11894** = 34-7/16" (875 mm)  
**K-11895** = 38-7/16" (976 mm)  
**K-11896** = 44-7/16" (1129 mm)  
**K-11897** = 50-7/16" (1281 mm)

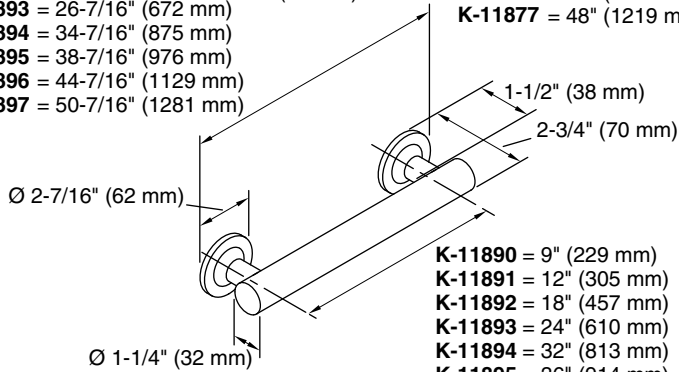

**K-11890** = 9" (229 mm)  
**K-11891** = 12" (305 mm)  
**K-11892** = 18" (457 mm)  
**K-11893** = 24" (610 mm)  
**K-11894** = 32" (813 mm)  
**K-11895** = 36" (914 mm)  
**K-11896** = 42" (1067 mm)  
**K-11897** = 48" (1219 mm)

## Installation/Installation/Instalación

- 1** Place grab bar or template in desired position. Level, if desired.  
Placer la barre d'appui ou le gabarit en position désirée. Nivelier si désiré.  
Coloque la agarradera o plantilla en la posición deseada. Nivele, si desea.

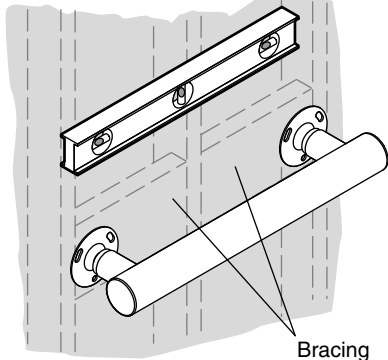

Bracing  
Renfort  
Refuerzo

- 2** Mark three holes on each wall plate.  
Marquer trois orifices sur chaque plaque murale.  
Marque tres orificios en cada placa mural.

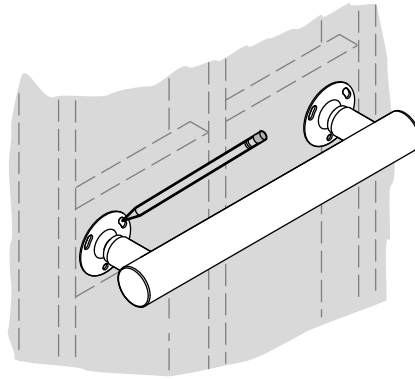

**Note:** Proceed to step 4 if installing to drywall.

**Remarque:** Procéder à l'étape 4 dans le cas d'installation à une cloison-sèche.

**Nota:** Prosiga al paso 4 si va a instalar en panel de yeso.

- 3** Ceramic Tile  
Carrelage en céramique  
Azulejo de cerámica

Drill through ceramic tile only using 3/16" or #12 bit. Apply silicone sealant into six drilled holes.

Percer le carreau en utilisant uniquement une mèche de 3/16" ou n°12. Appliquer un boudin de mastic à la silicone dans les six orifices percés.

Taladre sólo a través del azulejo de cerámica utilizando una broca de 3/16" o #12. Aplique sellador de silicona en los seis orificios taladrados.

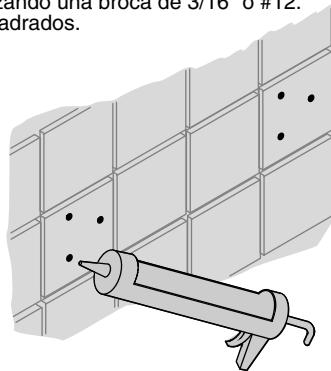
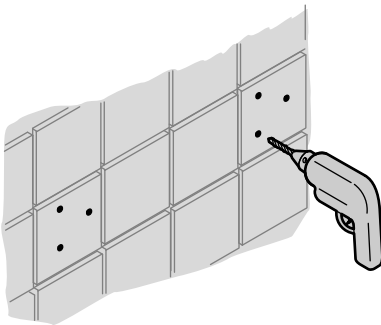

## Installation/Installation/Instalación

- 4** Loosen the setscrew and remove the wallplate.  
Desserrer la vis de retenue et retirer la plaque murale.  
Afloje el tornillo de fijación y retire la placa mural.

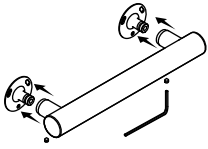

- 5** Secure each wall plate with three screws provided.  
Sécuriser chaque plaque murale avec trois vis fournies.  
Fije cada placa mural con los tres tornillos provistos.

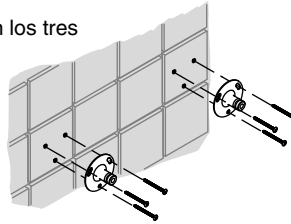

- 6** Slide the escutcheons onto the grab bar.  
Glisser l'applique sur la barre d'appui.  
Deslice los chapetones en la agarradera.

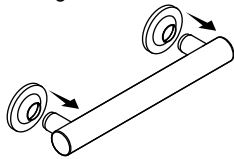

- 7** Slide escutcheons over wall plates. Secure the grab bar in place with the setscrews provided.  
Glisser les appliques sur les plaques murales. Sécuriser la barre d'appui avec les vis de retenue fournies.  
Deslice los chapetones sobre las placas murales. Fije la agarradera en su lugar con los tornillos de fijación provistos.

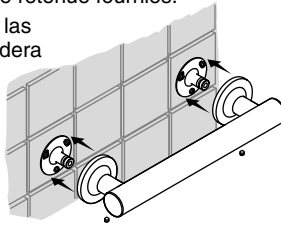

## Care and Cleaning

For best results, keep the following in mind when caring for your KOHLER product:

- Always test your cleaning solution on an inconspicuous area before applying to the entire surface.
- Wipe surfaces clean and rinse completely with water immediately after applying cleaner. Rinse and dry any overspray that lands on nearby surfaces.
- Do not allow cleaners to soak on surfaces.
- Use a soft, dampened sponge or cloth. Never use an abrasive material such as a brush or scouring pad to clean surfaces.
- The ideal cleaning technique is to rinse thoroughly and blot dry any water from the surface after each use.

For detailed cleaning information and products to consider, visit [www.kohler.com/clean](http://www.kohler.com/clean). To order Care & Cleaning information, call 1-800-456-4537.

## Entretien et nettoyage

Pour obtenir les meilleurs résultats possibles, prendre ce qui suit en considération lors de l'entretien de votre produit KOHLER:

- Toujours tester la solution de nettoyage sur une surface non visible avant de l'appliquer sur l'ensemble de la surface.
- Essuyer les surfaces et rincer complètement avec de l'eau immédiatement après l'application du nettoyant. Rincer et sécher tout éclaboussement sur les surfaces avoisinantes.