

1	2	3	4	5	6	7
NO	P/N	Tooling	Working process Description			
1	SQZ-75					

REVISIONS		
SYM.	BY.	DATE
A.		

F
D
C
B
A

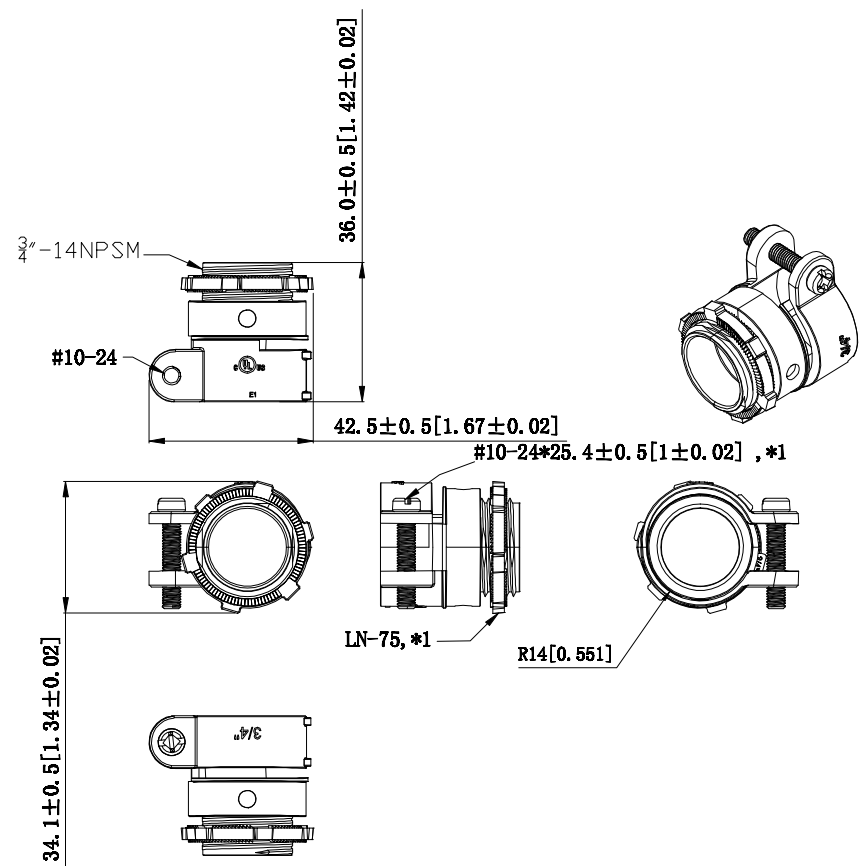

NOTES:
 1. All dimensions in millimeters and [inches];
 2. Free of sharp edge and burrs. max burr 0.5 [0.0196].
 3. Material: #3 ZAMAK

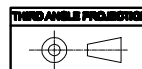

TOLERANCE SPECIFIED UNLESS NOTED OTHERWISE X.X ±0.05[±0.002] X.XX ±0.01[±0.0004] X.XXX ±0.005[±0.0002]	NAME DRAWN CHECKED APPROVED (F) APPROVED (Customer)	DATE 2014.01.08
MATERIAL #3 ZAMAK	TITLE ELECTRICAL TRADE WASHERS	
FINISH DO NOT OILS FINISHS SHEET METAL FABRY/MAM-4884	SIZE AA	DWG NO. SQZ-75
THIS DRAWING IS THE PROPERTY OF GARVIN INDUSTRIES AND IS LOANED TO YOU FOR YOUR INFORMATION ONLY. IT IS NOT TO BE REPRODUCED OR TRANSMITTED IN ANY FORM OR BY ANY MEANS, ELECTRONIC OR MECHANICAL, INCLUDING PHOTOCOPYING, RECORDING, OR BY ANY INFORMATION STORAGE AND RETRIEVAL SYSTEM, WITHOUT THE WRITTEN PERMISSION OF GARVIN INDUSTRIES. ALL RIGHTS ARE RESERVED. THIS DRAWING IS THE PROPERTY OF GARVIN INDUSTRIES.	SCALE: 1:1	PART DATE REVISIONS

GARVIN INDUSTRIES		
TITLE ELECTRICAL TRADE WASHERS		
SIZE AA	DWG NO. SQZ-75	REV
SCALE: 1:1	PART DATE	REVISIONS
		SHEET 1 OF 1