

# INSTALLATION | WOOD INSTALL KIT 4x4 / 6x6

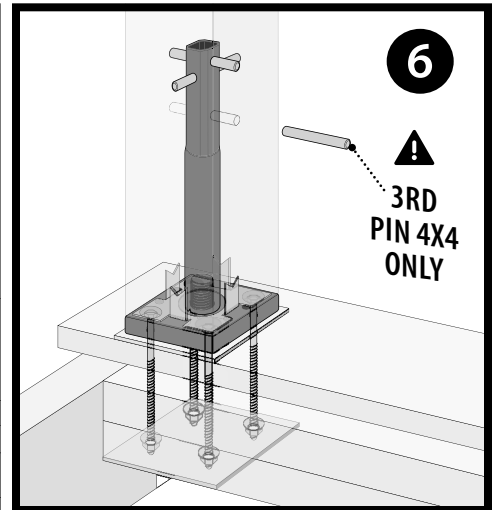
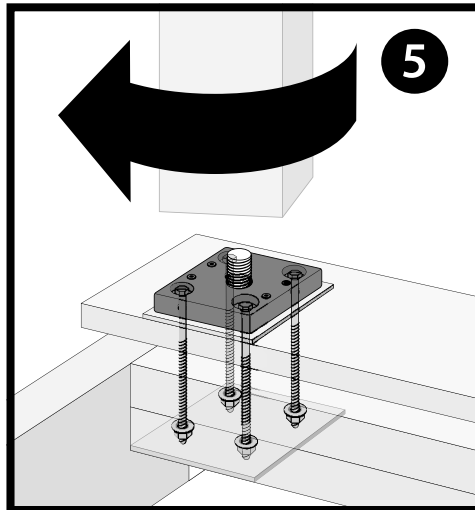
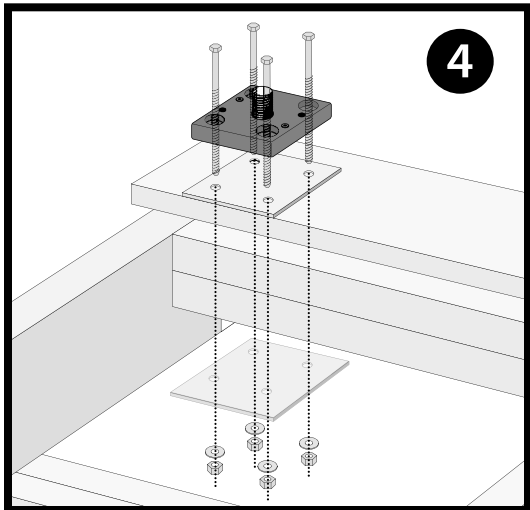
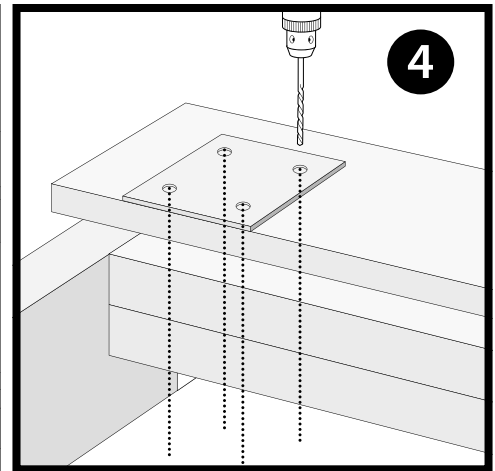
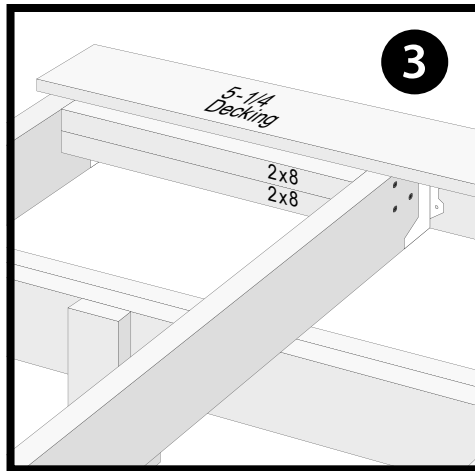
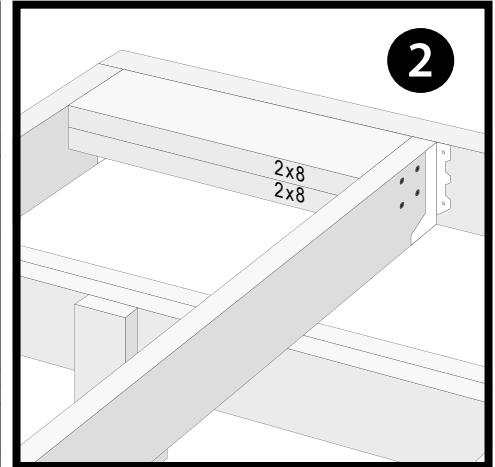
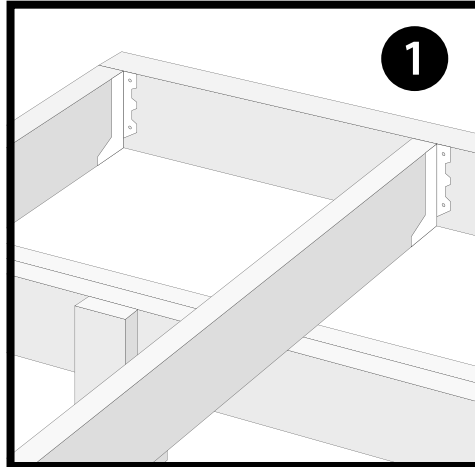
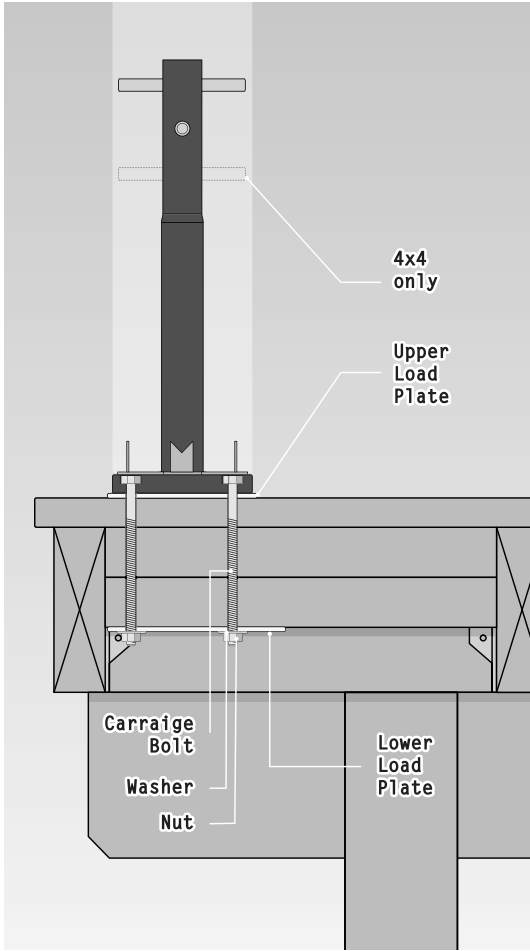

WOOD INSTALL KIT / WK35 / WK55 FOR TITAN STRUCTURAL POST ANCHOR

PATENT NO

PENDING

IN NO EVENT SHALL TITAN BUILDING PRODUCTS BE LIABLE FOR ANY LOSS OR DAMAGE, DIRECT OR OTHERWISE, WHICH RESULTS FROM THE IMPROPER INSTALLATION OR USE OF THIS PRODUCT. IF FOR ANY REASON TITAN BUILDING PRODUCTS BECOMES LIABLE FOR LOSS OR DAMAGE, DIRECT OR OTHERWISE, THE AGGREGATE LIABILITY OF TITAN BUILDING PRODUCTS SHALL BE LIMITED TO THE RETAIL PURCHASE PRICE OF THE PRODUCTS.

QUESTIONS? CONTACT US TOLL FREE

1-866-577-8868



titanbuildingproducts.com

