











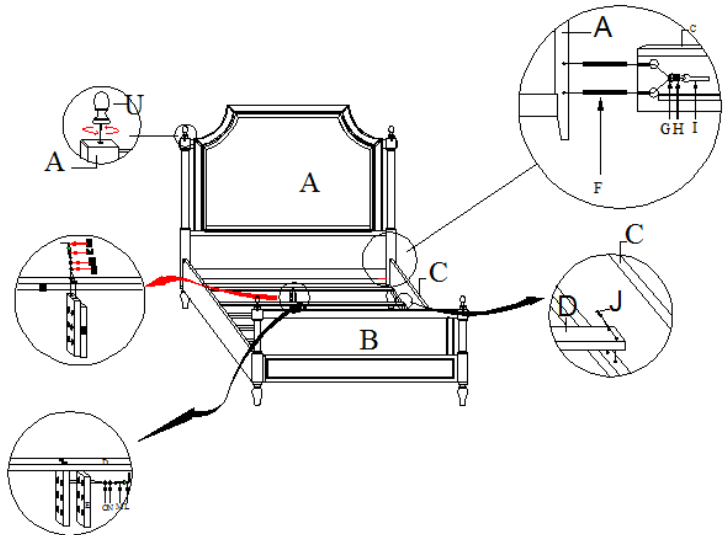


# ASSEMBLY INSTRUCTION

ITEM# 5701-90667 6/0-6/6 Uph Poster Headboard-Fabric  
 5701-90668 6/0-6/6 Wood Poster Footboard  
 5701-90653 5/0-6/6 Wood Poster Rails  
 5701-90170 6/6 Canopy

**Caution: Please make sure you have all parts indicated below prior to assembly.  
 This bed is heavy and can best be assembled with the help of two or more persons.**

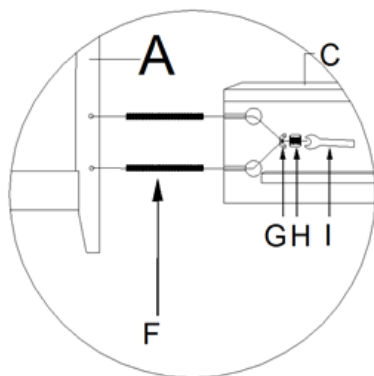
NO.	HARDWARE LIST		Q'TY
F		FULL THREADED BOLT	8
G		CURVED WASHER	8
H		NUT	8
I		SPANNER WRENCH	1
J		SCREW	20
L		4MM ALLEN WRENCH	1
M		35MM* 1/4" BOLT	10
N		1/4" LOCK WASHER	10
O		1/4" FLAT WASHER	10
P		5MM ALLEN WRENCH	1
T		15MM* 5/16" BOLT	12
R		5/16" LOCK WASHER	12



**Please note the hardware bag to assemble side rails to HB&FB is in the box of side rails.**

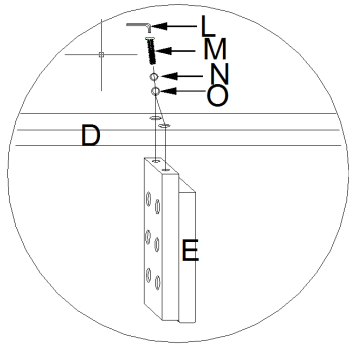
## Assembly steps:

1. Insert 2 bolts (F) into holes of each side post on Headboard (A) and Footboard (B), attach the end of side rails (C) to bolts (F) on posts by using 2 curved washers (G) and 2 nuts (H), tighten nuts (H) securely with spanner wrench (I). (See diagram 1)



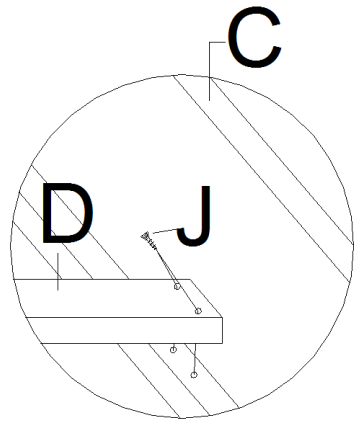
**Diagram 1**

2. Take out center supports (E) from the rail box, attach center supports (E) to slats by using 2 bolts (M), 2 lock washers (N) and 2 flat washers (O). Secure bolts (M) by using allen wrench (L). (See diagram 2)



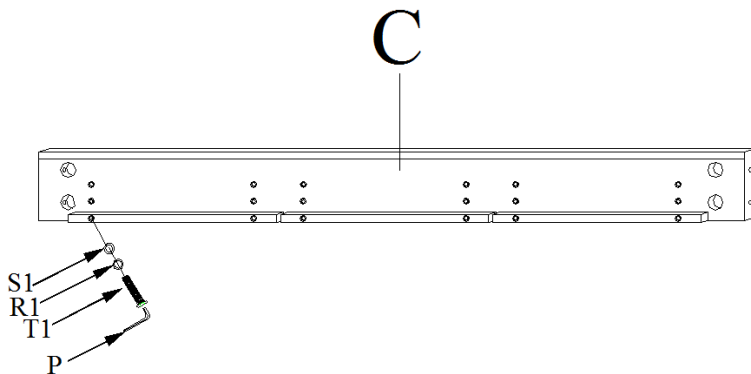
**Diagram 2**

3 Attach slats (D) to side rails (C), align pre-drilled holes on the slat to holes on the cleat of side rail (C), using screws (J) to tighten both. (See diagram 3)



**Diagram 3**

Note: You can change the height of slat by adjusting the height of cleat on side rail as shown in diagram 4. Remove bolt (T1), lock washer (R1) and flat washer (S1) from the cleat by turning the bolt (T1) with allen wrench (P) in anti-clockwise direction. Adjust the cleat to a desired position, and then secure lock washer, flat washer, bolt in a clockwise direction by turning with allen wrench.



**Diagram 4**

You can adjust the height of center supports (E) as shown in Diagram 5 to meet your need by the following steps.

1. Unscrew bolts on center supports (E) with allen wrench (L).

- Adjust the height of center supports, align the holes on 2pcs of woods and tighten them together with 2 bolts (M), 2 lock washers (N) and 2 flat washers (O) by turning with allen wrench (L) in a clockwise direction.

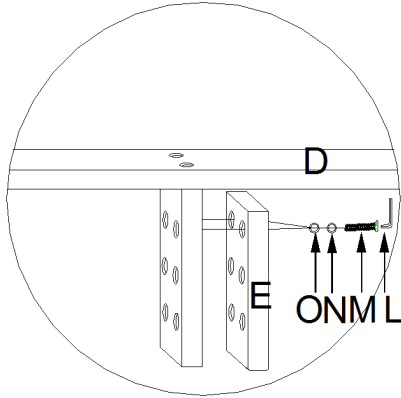
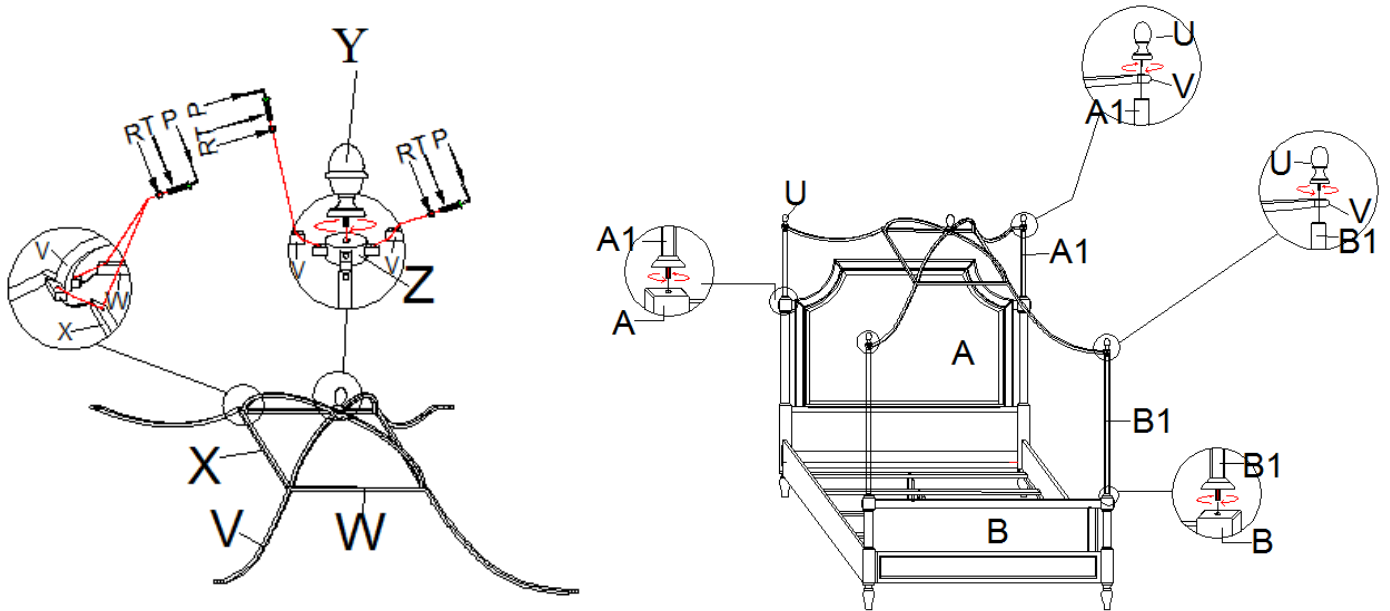
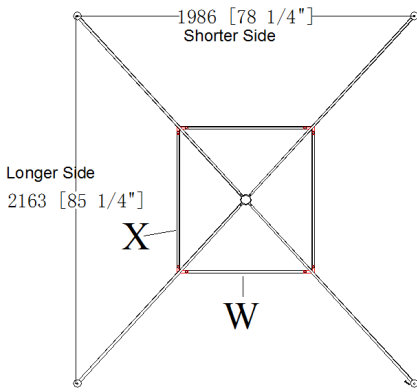


Diagram 5

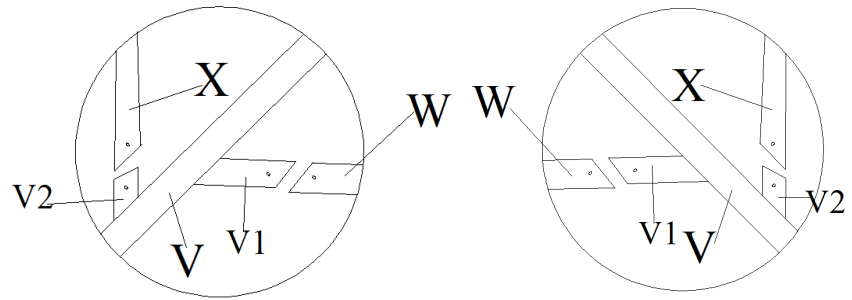
**Assembly steps for HB/FB posts and metal canopy.**



- The shorter side is for headboard or footboard which size is 78 1/4", the longer side is for side rail which size is 85 1/4" (See diagram 6). Rail(X) is located on the longer side, and rail(W) is located on the shorter side, rail(X) is connected to the shorter end(V1), rail(W) is connected to the longer end(V2) (See diagram 7 & diagram 8) please do not mix up.



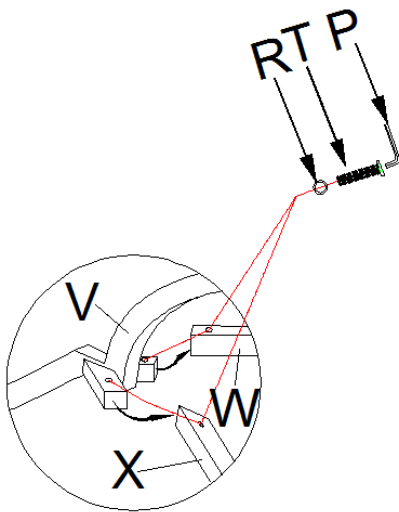
**Diagram 6**



**Diagram 7**

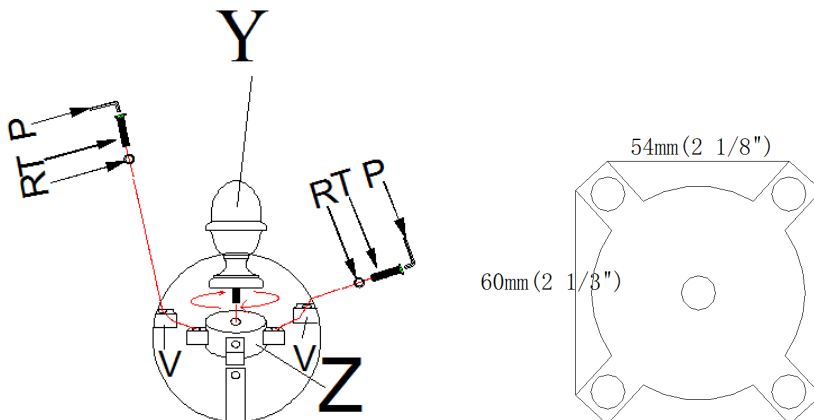
**Diagram 8**

2. Assemble stretchers(V) to rails(X&W), align pre-drilled holes on rails to holes on the stretchers, using bolts(T), lock washers(R), secure all bolts with allen wrench(P) in a clockwise direction(See Diagram 9).



**Diagram 9**

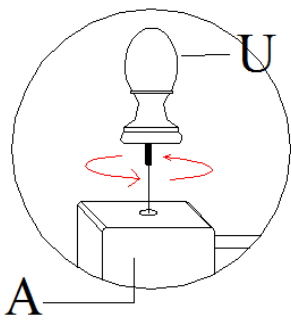
3. Align holes(V) on top side of stretchers to holes on center connector(Z), secure bolts(T), lock washers(R) by using allen wrench(P) in a clockwise direction(See Diagram 10), Screw finial(Y) through center connector(Z) in a clockwise direction by hand. The longer side of the center connector is 2 1/3", this side is paralleled to rail(X), the shorter side of the center connector is 2 1/8", and it is paralleled to rail(W).



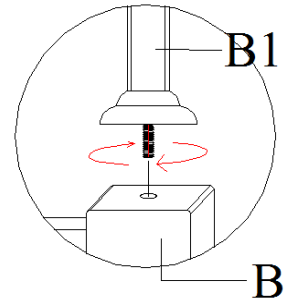
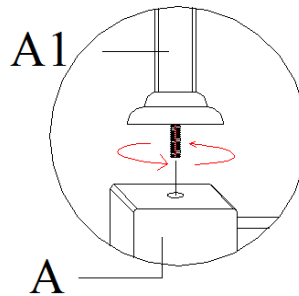
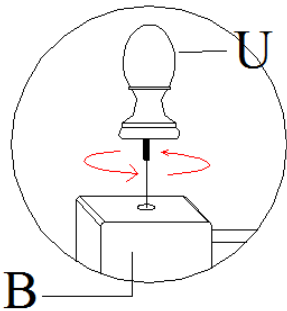
**Diagram 10**

4. Unscrew finials(U) on HB/FB by turning it in an anticlockwise direction(See Diagram 11), Then tighten posts(A1&B1) to HB(A)&FB(B) by turning in a clockwise direction(See Diagram 12).

**Note: A1 is shorter than B1.**

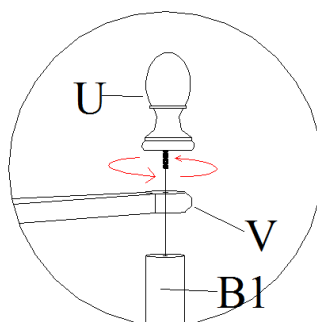
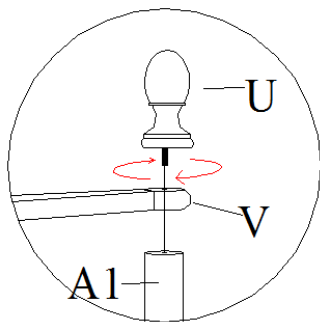


**Diagram 11**



**Diagram 12**

5. Well place assembled canopy on HB&FB posts by aligning holes and tighten by turning the finials in a clockwise direction.(See diagram 13)



**Diagram 13**

Note: The shorter side of assembled canopy towards headboard/footboard, longer side towards side rail.

**Cleaning Instruction: Clean finished parts with a mild dishwashing liquid and water solution on a damp cloth. Polish the finish with soft cloth and an industry recognized furniture polish.**