

Springdale 2-Way Adjustable Entry Door Handle Oil Rubbed Bronze

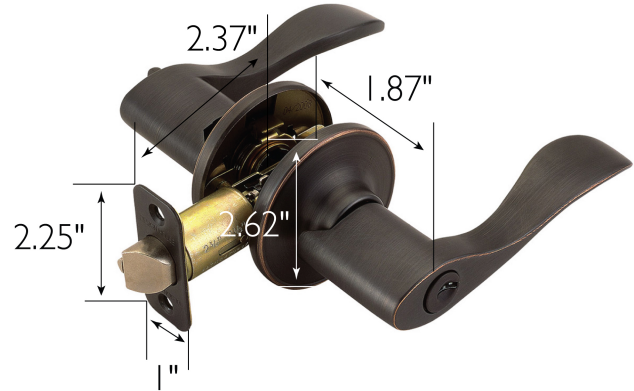

SPECIFICATIONS

MATERIAL CONSTRUCTION:	Brass	KEYWAY:	KW
LOCK FUNCTION:	Entry Knob/Lever	REMOVABLE CORE:	No
DEADBOLT FUNCTION:	N/A	LATCH FACEPLATE I:	Round Corner
EXTERIOR MAX PROJECTION:	2.94"	LATCH BACKSET:	Adj; 2-3/8" - 2-3/4"
INTERIOR MAX PROJECTION:	2.94"	LATCH TYPE:	2 Way (fixed faceplate)
KOB VS. LEVER:	Lever	LATCHBOLT THROW DISTANCE:	0.5"
KNOB DIMENSIONS:	N/A	# PINS IN CYLINDER:	5
LEVER LENGTH:	3.67"	ANTI-BUMP PIN INSTALLED:	Yes
ROSE DIMENSIONS:	2.63" H x 2.63" W x 2.63" D	# KEYS INCLUDED:	2
ROSETTE / ESCUTCHEON SHAPE:	Round	SPINDLE TYPE:	Half-Moon
CROSS BORE:	2.13"	MOUNTING HARDWARE INCLUDED:	Yes
EDGE BORE:	1"	TOOLS NEEDED FOR INSTALLATION:	Phillips Screwdriver
HANDING:	Reversible	ASSEMBLED WEIGHT:	2 lbs.
REKEYABLE?:	Yes		

WARRANTY:	5-Year limited warranty
ANSI CERTIFICATION:	Grade 3
BHMA GRADE:	3
FIRE RATED:	No
ADA COMPLIANT:	No



TYPE: JOB: ORDER CODE: APPROVALS:
--