

Seat shall be Comfort™ Seats

Model Number C106CEZ-00

Commercial Plastic Toilet Seat

Elongated Open Front Less Cover

Category

COMMERCIAL & HOSPITALITY

Features

- Injection molded durable polypropylene plastic with UV protection
- Patented Comfort™ Seats EZ Close™ damper system minimizes risk of cracked toilet bowls from slamming seats
- Hinge functions as both a standard check and self-sustaining check model
- Chrome finish metal hinge for ease of cleaning and hygienic requirements
- Hinges are completely hidden under the seat to minimize risk of pinching
- No pinching of fingers - Safer for children in schools, nurseries, and day cares
- 304 stainless steel non-corrosive hardware
- Perfect for Health Care/Assisted Living/Hospitality environments
- Anti-skid rubberized bushing/washer prevents movement and loosening of seat

Seat Color/Finish

Specify white

Hinge Color/Finish

Specify white

Product Specifications

Hinge Design: External EZ Close™ hinge with 304 stainless steel mounting hardware

Ring Thickness: 7/8"

Ring Thickness with Bumper: 1"

Height of Seat with Cover: N/A

Size: ANSI Standard Toilet - Meets Z124.5 Section 5.1.2

Additional Information

All seats feature UV protection.

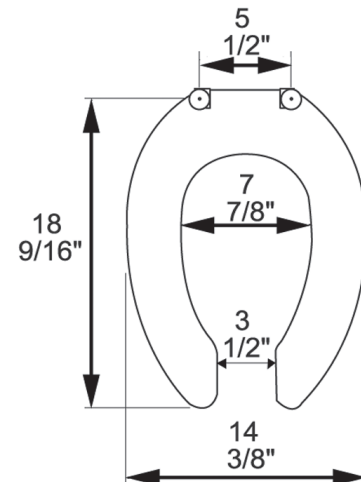

304 stainless steel non-corrosive hardware

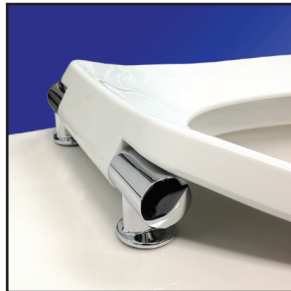

Chrome finish metal EZ Close™ hinges

