



P12-DGC-USA

12 [305] Wide Domestic Grate

Dimensional data (Imperial and [Metric]) are subject to manufacturing tolerances and change without notice. Linear (in[mm]), area (in²[cm²], and weight (lbs[kg])

[Back to Index](#)

Please Check ✓	Item No.	Part Number	Item I.D.
	11	84225	P12-DGC-USA

Supersedes
65913

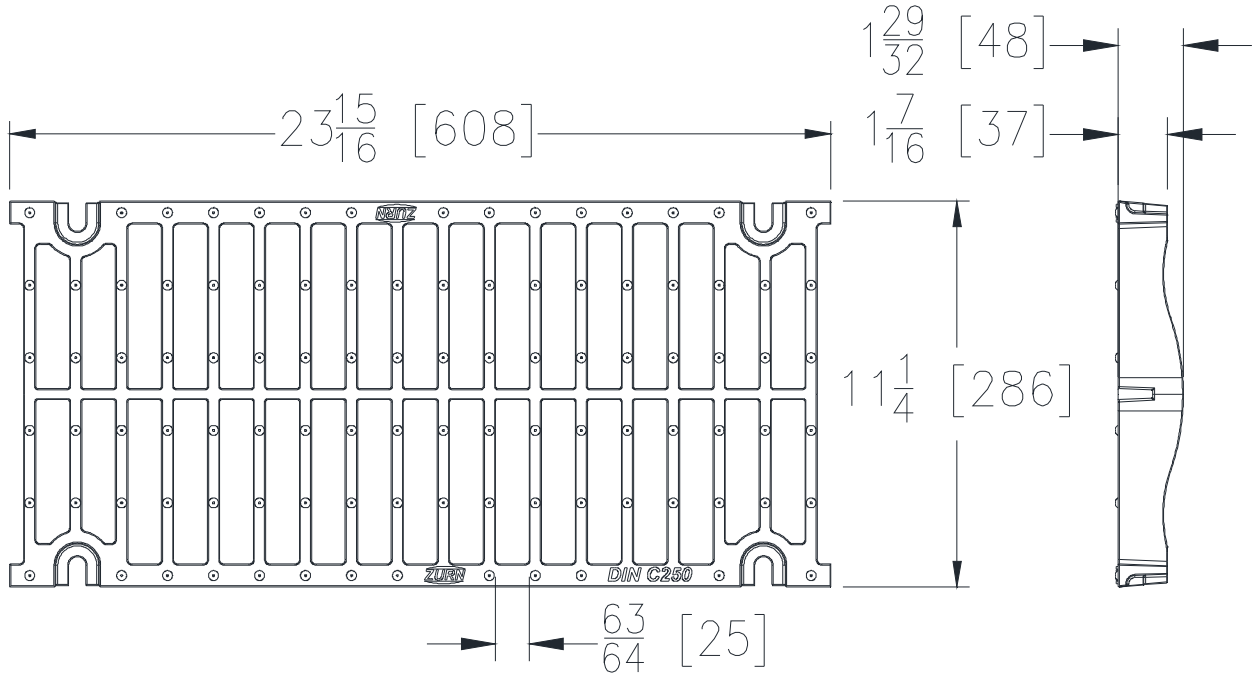

DGC-USA GRATE ENGINEERING SPECIFICATION: The Zurn P12-DGC-USA Ductile Iron Slotted Grate, is 11-1/4" [286mm] wide X 23-15/16" [608 mm] long, weighing 14.7 lbs per linear foot [22 kg/m]. The grate has an open area of 86.7 in² per linear foot [1835 cm²/m], DIN Rating of C, ANSI Rating of Heavy-Duty, and H-20 Load Rated. Ductile Iron conforms to ASTM A536 Grade 80-55-06.

DGC-USA -Ductile Iron	
Material:	Ductile Iron
DIN Rating:	Class C
Weight:	14.7 lbs/ft. [22 kg/m]
Open Area:	86.7 in ² /ft. [1835 cm ² /m]
ANSI Rating:	Heavy-Duty
Application:	Vehicle & Truck
Slot Width/Hole Size:	63/64 [25]
ADA:	No
H-20:	Yes
FAA:	No

