

**BATTERY SAFETY INFORMATION:** Batteries are small objects. Replacement of batteries must be done by adults. Follow the polarity (+/-) diagram in the battery compartment. Promptly remove dead batteries from the toy. Dispose of used batteries properly. Remove batteries for prolonged storage. Only batteries of the same or equivalent type as recommended are to be used. DO NOT incinerate used batteries. DO NOT dispose of batteries in fire, as batteries may explode or leak. DO NOT mix old and new batteries or types of batteries (i.e. alkaline/standard/rechargeable). Using rechargeable batteries is not recommended due to possible reduced performance. Rechargeable batteries are only to be charged under adult supervision. Replaceable-rechargeable batteries are to be removed from the toy before being charged. DO NOT recharge non-rechargeable batteries. DO NOT short-circuit the supply terminals.

**SPECIAL LiFe BATTERY INSTRUCTIONS:** Never charge battery unattended. - Charge battery in an isolated area. Keep away from flammable materials. - Do not expose to direct sunlight. There is a risk of the batteries exploding, overheating, or igniting. - Do not disassemble, modify, heat, or short-circuit the batteries. Do not place them in fires or leave them in hot places. - Do not drop or subject to strong impacts. - Do not allow the batteries to get wet. - Only charge the batteries with the specified Spin Master™ battery charger. - Only use the batteries in the device specified by Spin Master™. - Carefully read the instruction guide and use the batteries correctly. - In the unlikely event of leakage or explosion use sand or a chemical fire extinguisher for the battery. - Batteries must be recycled or disposed of properly.

**PRODUCT BATTERY REMOVAL INSTRUCTIONS:** Internal battery is factory installed and non-replaceable. Product disassembly and battery removal must be performed by an adult. Do not puncture, cut, tear, compress or deform product during disassembly. Ensure product is turned off, then use a screw driver to remove all screws. Separate product body halves to expose internal electronics. When battery is visible in its entirety, use scissors to cut a single battery wire, immediately wrap the cut wire end with tape to isolate it, repeat until all battery wires are cut and isolated, and the battery is free from the rest of the product. Dispose of battery in accordance with your local battery recycling or disposal laws.

**FCC STATEMENT:** This device complies with Part 15 of the FCC rules. Operation is subject to the following two conditions: (1) This device may not cause harmful interference, and (2) This device must accept any interference received, including interference that may cause undesired operation. This equipment has been tested and found to comply with the limits for Class B digital devices pursuant to Part 15 of the FCC rules. These limits are designed to provide reasonable protection against harmful interference to radio communications. This equipment generates, uses and can radiate radio frequency energy and, if not installed and used in accordance with the instruction, may cause harmful interference to radio communication. However, there is no guarantee that interference will not occur in a particular installation. If this toy does cause interference to radio or television reception (you can check this by turning the toy off and on while listening for the interference), one or more of the following measures may be useful:

- Reorient or relocate the receiving antenna.
- Increase the separation between the toy and the radio or the TV.
- Consult the dealer or an experienced TV-radio technician for help.

**NOTE:** Changes, adjustments or modifications to this unit, including but not limited to, replacement of any transmitter component (crystal, semiconductor, etc.) could result in a violation of FCC rules under part 15 and/or 95 and must be expressly approved by Spin Master Ltd or they could void the user's authority to operate the equipment. Spin Master Inc., PMB #10053, 300 International Drive, Suite 100, Williamsville, NY 14221. To contact the responsible party please visit [fcc.spinmaster.com](http://fcc.spinmaster.com).

This toy is only to be connected to equipment bearing either of the following symbols:

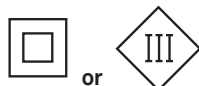

Do not change or modify anything on the toy.

**BEFORE FIRST USE:** Read the user's information together with your child.

**WARNING:** Do not aim at eyes or face.

Spin Master Ltd., 225 King Street West, Toronto ON M5V 3M2 Canada  
 Spin Master Inc., PMB #10053, 300 International Drive, Suite 100, Williamsville, NY 14221  
 Spin Master International B.V., Kingsfordweg 151, 1043 GR Amsterdam, NL  
 Spin Master Australia Pty Ltd, Suite 101, Level 1, 18-24 Chandos Street, St Leonards, NSW 2065; ☎1800 316 982  
 Spin Master Toys UK Ltd, Secure Trust House, Boston Drive, Bourne End, Buckinghamshire, SL8 5YS, UK

Spin Master logo & © Spin Master Ltd. All rights reserved. Retain this information, addresses and phone numbers for future reference. Content may vary from pictures. Keep away from obstacles and electrical hazards. Spin Master Ltd. reserves the right to discontinue the [www.AIRHOGS.com/JUMPFURY](http://www.AIRHOGS.com/JUMPFURY) website at any time.

MADE IN CHINA

For in-depth video instructions go to  
**AIRHOGS.COM/JUMPFURY**

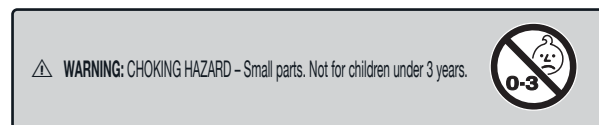

Frequency Band(s): 2.422 – 2.467 GHz  
 Maximum radio frequency power transmitted: < 10dBm

**CE** Spin Master International BV hereby declares that the radio equipment type **JUMP FURY™** is in compliance with Directive 2014/53/EU. The full text of the EU declaration of conformity is available at the following internet address: <http://doc.spinmaster.com>

T44648\_0001\_20130279\_GEN\_IS\_R3

**?** NORTH AMERICA – 1-800-622-8339  
 customercare@spinmaster.com  
 UK – 0800 206 1191, serviceuk@spinmaster.com  
 IRELAND – 1800 992 249  
 AUSTRALIA – 1800 316 982, customercare@spinmaster.com

**WWW.SPINMASTER.COM**



**4+ YRS**

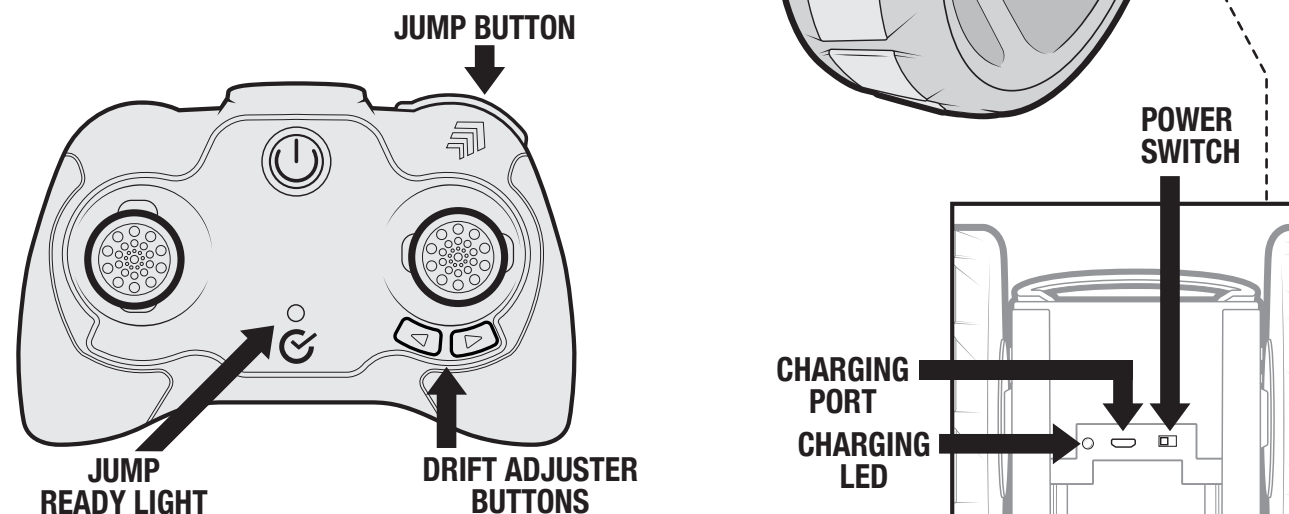
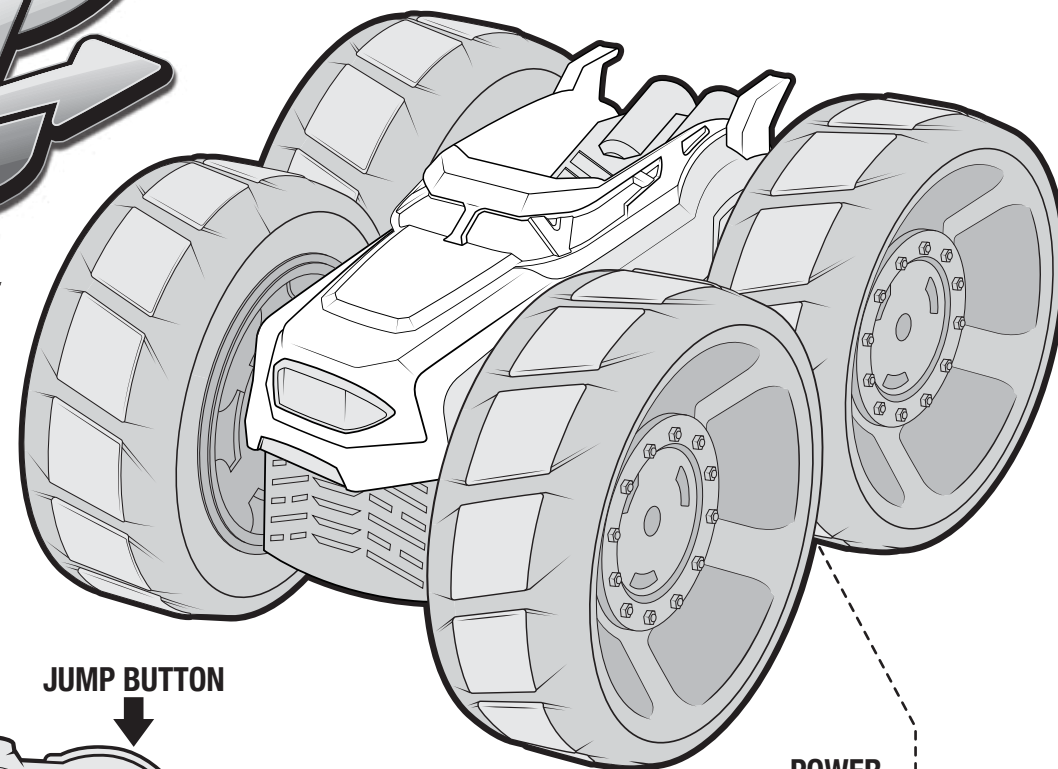

For in-depth video instructions go to  
**AIRHOGS.COM/JUMPFURY**

**CONTENTS**

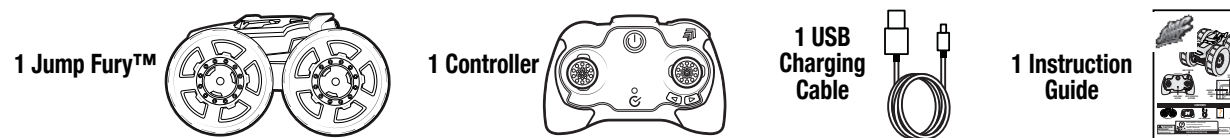

**CAUTION:**  
**HAIR ENTANGLEMENT –**  
 Tie back and cover hair and secure loose clothing prior to play.

**?** NORTH AMERICA – 1-800-622-8339  
 customercare@spinmaster.com  
 UK – 0800 206 1191, serviceuk@spinmaster.com  
 IRELAND – 1800 992 249  
 AUSTRALIA – 1800 316 982, customercare@spinmaster.com

**WWW.SPINMASTER.COM**

**BC**  
**2xAAA (LR03) 1.5V**  
**Not Included**

## HOW TO INSTALL BATTERIES

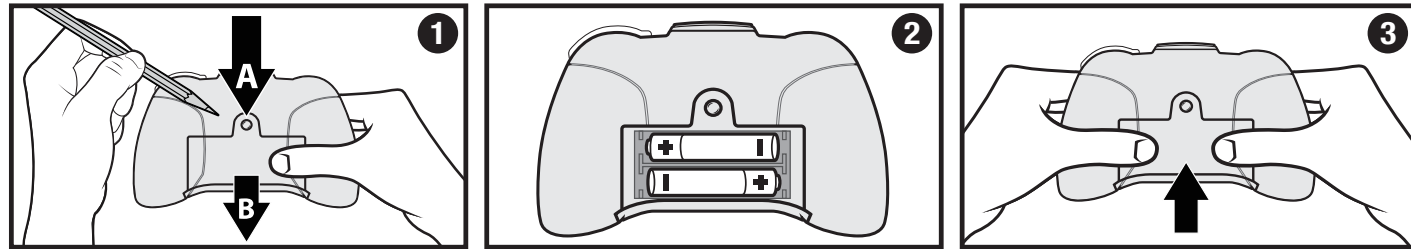

1. Press down on release button (A) to slide down battery cover (B).

2. Install new batteries as shown in the polarity diagram (+/-) inside the battery compartment.

3. Replace battery door securely. Check your local laws and regulations for correct recycling and/or battery disposal.

## HOW TO CHARGE

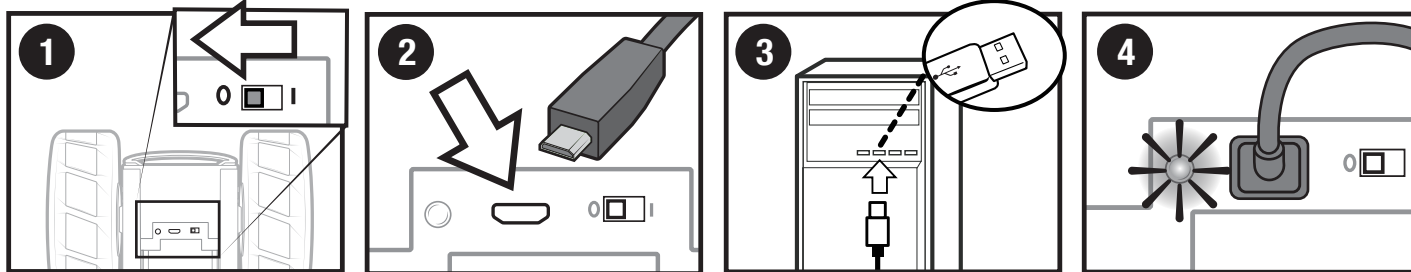

1. Turn the vehicle off.

2. Plug the small end of the charging cable into the charging port.

3. Plug the charging cable into a 5V DC computer outlet.

4. Blinking LED indicates battery is charging, solid ON for fully charged.

## HOW TO CONNECT THE CONTROLLER

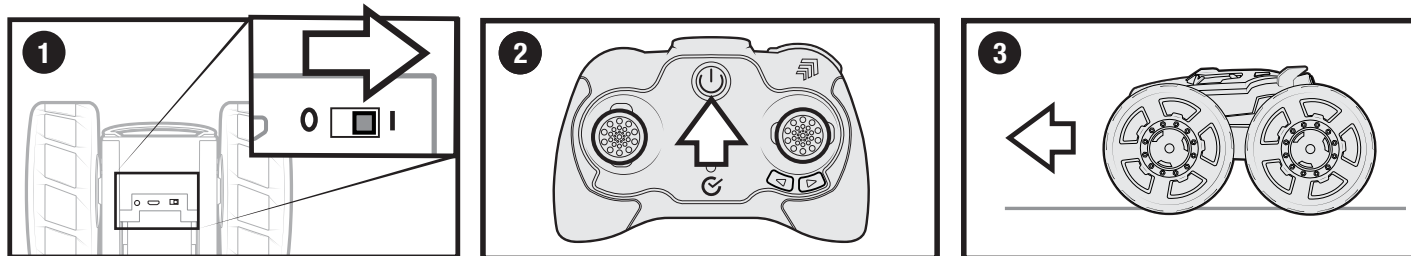

1. Turn on the vehicle and place it on a flat surface.

2. Hold the controller near your Jump Fury™, press the power button and wait until the power light stops flashing.

3. You are ready to drive.  
4. Use the remote control to drive.

## CONTROLLER NOT CONNECTING

If your vehicle does not connect to the controller the first time, turn the vehicle off, remove batteries from the controller, put the batteries back in and repeat the HOW TO CONNECT THE CONTROLLER instructions.

## HOW TO JUMP

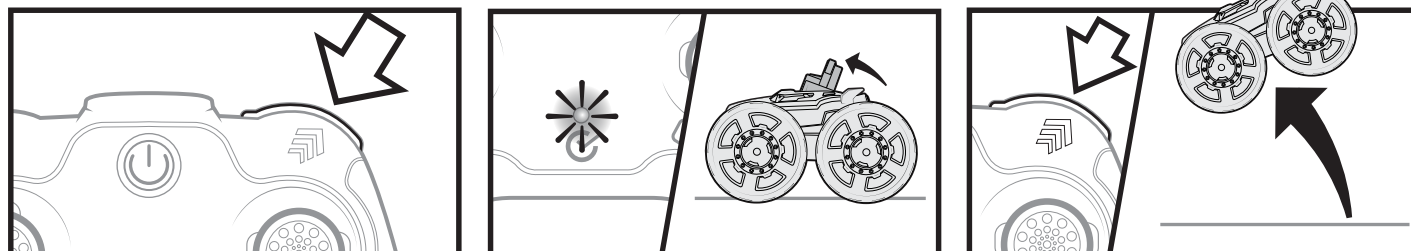

1. Press the JUMP BUTTON once to load a jump. The JUMP FURY™ will begin loading a jump. (Loading take approximately 7 - 10 seconds).

2. When the JUMP READY LIGHT is solid ON the JUMP FURY™ is ready to jump.

**NOTE: If the Jump Ready Light is blinking and the mechanism is fully loaded but not jumping, move the vehicle to a flatter surface.**

3. Press the JUMP BUTTON on the controller to launch the JUMP FURY™.

## HOW TO DRIVE

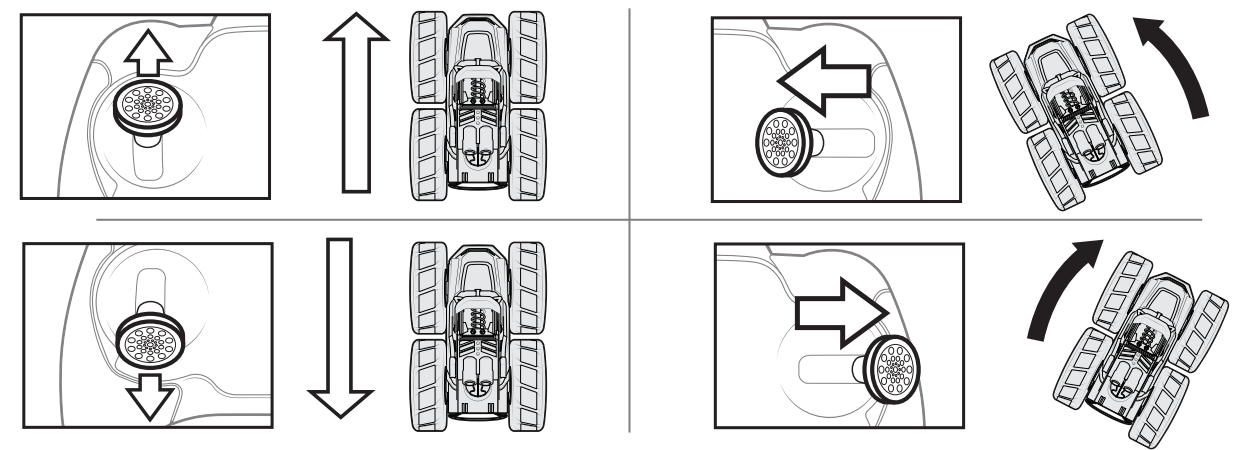

## HOW TO CORRECT WHEEL ALIGNMENT

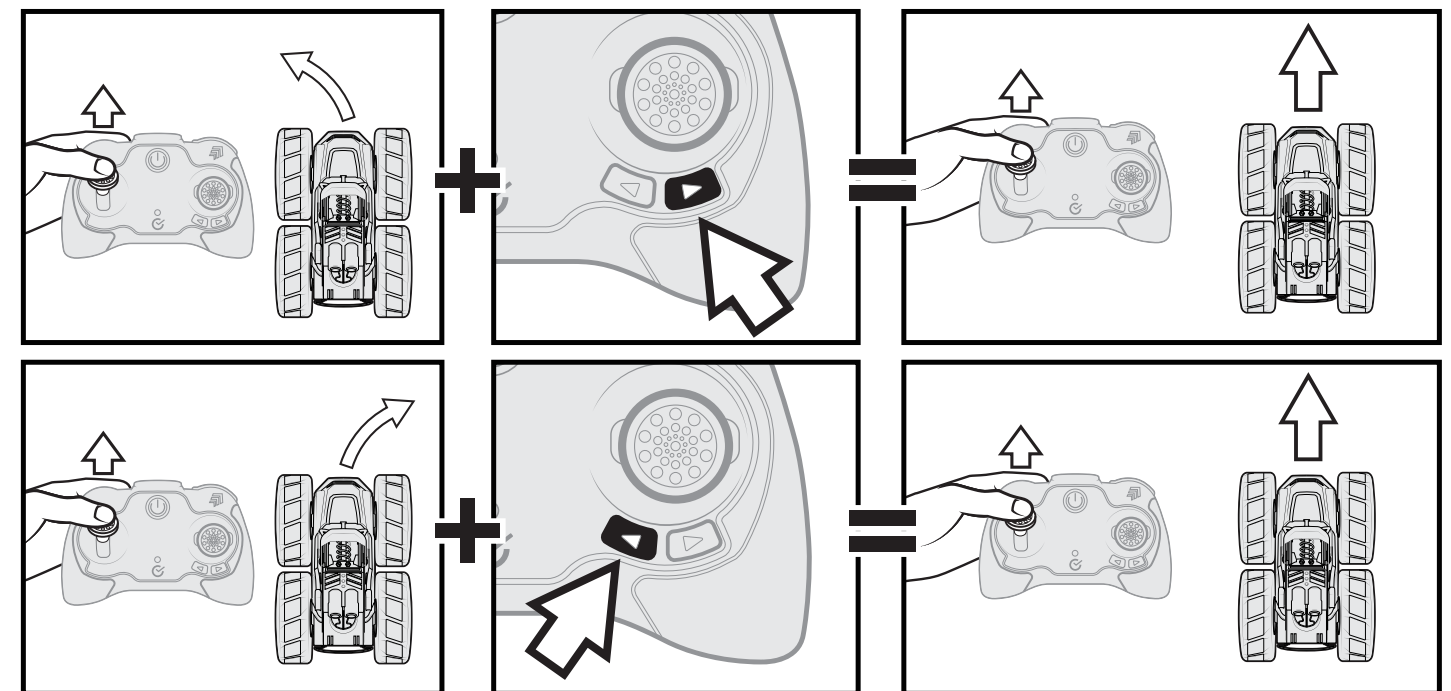

For TROUBLESHOOTING questions and solutions, please visit our website:  
[AIRHOGS.COM/JUMPFURY](http://AIRHOGS.COM/JUMPFURY)

**NOTE:** If normal function of the product is disturbed or interrupted, strong electromagnetic interference may be causing the issue. To reset product, turn it completely off, then turn it back on. If normal operation does not resume, move the product to another location and try again. To ensure normal performance, change the batteries, as low batteries may not allow full function.

**Safety Precautions:** - Keep hands, hair and loose clothing away from the motor / wheels when power switch is turned ON. - Remove batteries when not in use. - Parental guidance is recommended for the play. - Keep your toy in your sight so that you can supervise it all the time. - New alkaline batteries are recommended to obtain maximum performance. - Users should keep strict accordance with the instruction manual while operating the product.

**Note:** Parental guidance is recommended when installing or replacing batteries. Under the environment with electrostatic discharge, the toy may malfunction and require user to reset the toy.

**CARE AND MAINTENANCE:** Always remove batteries from the controller when it is not being used for a long period of time. Wipe the toy gently with a clean damp cloth. Keep the toy away from direct heat. Do not submerge the toy in water. This can damage the electronic assemblies.

**CONTAINS 1 X 3.2V LiFe 500mAh BATTERY PACK AND REQUIRES 2 x 1.5V AAA (LR03) ALKALINE BATTERIES (not included).** Batteries or battery packs must be recycled or disposed of properly. When this product has reached the end of its useful life, it should not be disposed of with other household waste. The Waste Electrical and Electronic Equipment Regulations require it to be separately collected so that it can be treated using the best available recovery and recycling techniques. This will minimize the impact on the environment and human health from soil and water contamination by any hazardous substances, decrease the resources required to make new products and avoid using up landfill space. Please do your part by keeping this product out of the municipal waste stream! The "wheelie bin" symbol means that it should be collected as "waste electrical and electronic equipment". You can return an old product to your retailer when you buy a similar new one. For other options, please contact your local council.