

SILVERBACK

BALL HOLDER

MODEL NO.
B5455

ESCALADE[®] SPORTS

PRE-ASSEMBLY TIPS

1. **Read this manual carefully before starting assembly.** Read each step completely before beginning each step.
2. **Do not tighten until instructed to do so.** If parts are tightened too soon, parts may not easily fit together.
3. **Save these instructions and your proof of purchase (receipt) in the event that the manufacturer has to be contacted for replacement parts.**

TOOLS NEEDED FOR ASSEMBLY:

Phillips Screw driver
Cordless Drill
5/6" Socket driver bit

Please Do Not Return This Product To The Store!

Contact Escalade[®] Sports customer service department at:

Phone: 1-800-USA-GOAL Toll - Free !

Fax: 1-866-873-3536 Toll - Free !

E-mail: basketball@escaladesports.com

Escalade Sports

Physical Location: **Mailing Address: (Correspondence Only)**

817 Maxwell Ave.

PO Box 889

Evansville, IN 47711

Evansville, IN 47706

PARTS LIST (NOT ACTUAL SIZE)

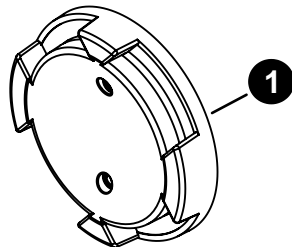

BASE
3M-9137-00
QTY. 1

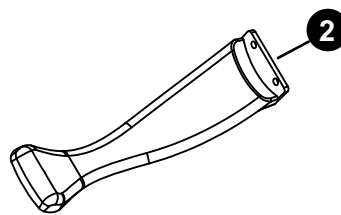

GRIPPER FINGER
3M-9138-00
QTY. 4

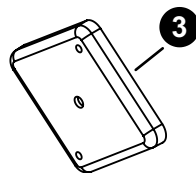

MOUNTING BRACKET
3M-9139-00
(QTY. 1)

HARDWARE NEEDED (ACTUAL SIZE)

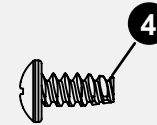

#8 X .375 Phillips Head
Trilobular Screw
1B-7225-00
QTY. 10

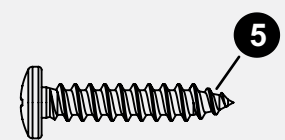

#10 X 1.0 Phillips screw
1B-7226-00
QTY. 1

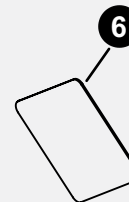

TAPE PATCH
1M-6289-00
QTY. 1

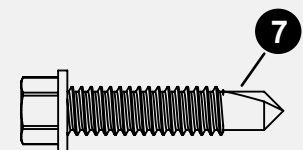

#10 X 1.125 Self Drilling Screw
1B-6821-00
QTY. 1

1. Assemble four Gripper Fingers (#2) to Base (#1) as shown in **Figure 1 & Back View**.

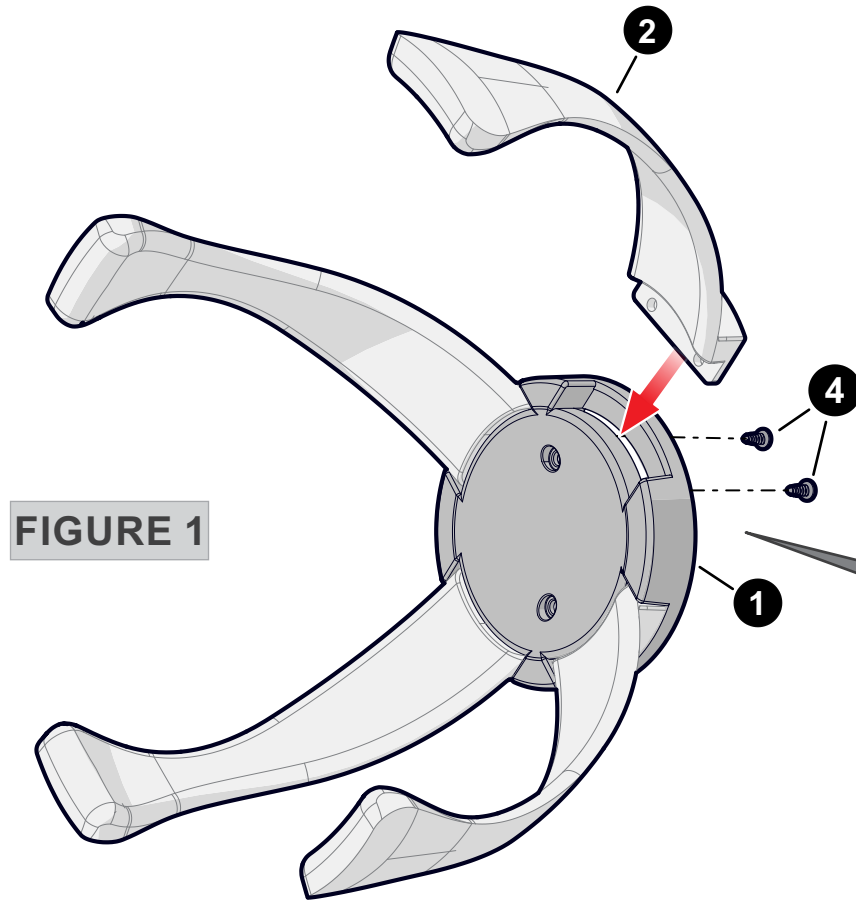
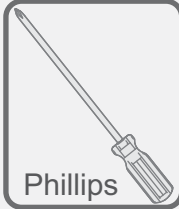
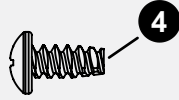
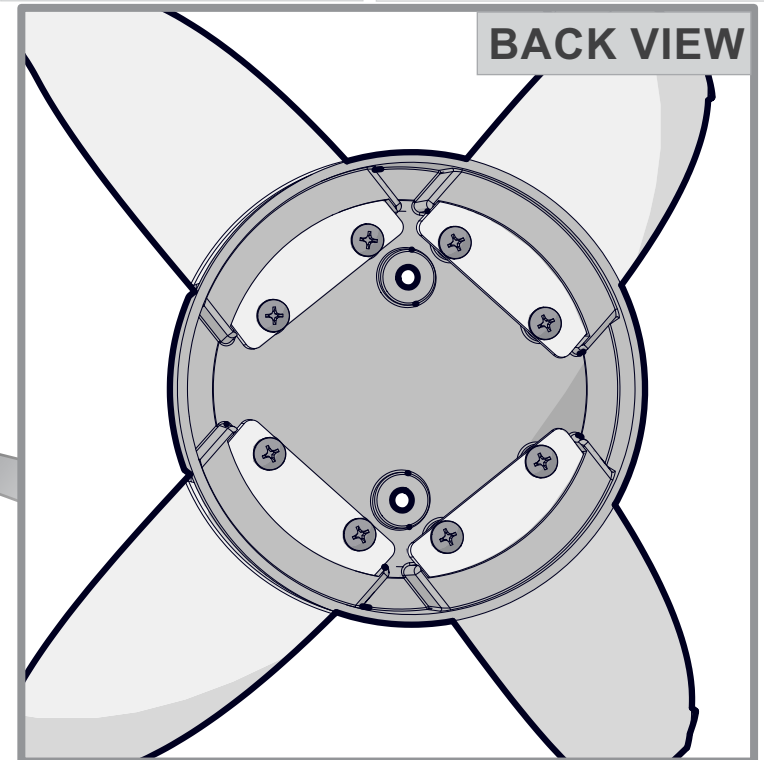
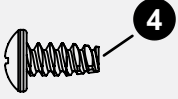
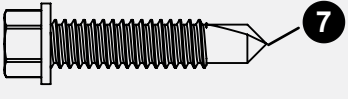





FIGURE 1

TOOL NEEDED	HARDWARE NEEDED
 <p>Phillips</p>	 <p>#8 X .375 Phillips Head Trilobular Screw 1B-7225-00 QTY. 8</p>



NOTE: Prepare hardware and tools below to be used for **page 3** assembly steps.

HARDWARE NEEDED		TOOLS REQUIRED		
 <p>#8 X .375 Phillips Head Trilobular Screw 1B-7225-00 QTY. 2</p>	 <p>#10 X 1.125 Self Drilling Screw 1B-6821-00 QTY. 1</p>	 <p>Cordless Drill</p>	 <p>5/6" Socket driver bit</p>	 <p>Phillips</p>



If installing to the back of a **basketball pole** continue onto **Step 2 on this page**. If mounting to a **Wall** skip this page and continue on **page 4**.

2. Clean the flat side of the mounting bracket surface with alcohol. Peel one side of the mounting **Tape (#6)** and adhere the to the **Flat** part of the **Mounting Bracket (#2)** as shown in **Detail A**.
3. Clean mounting location surface with alcohol. Peel the other side of the mounting tape and adhere mounting location. See **Detail B**.

NOTE: Holes in the Mounting Bracket (**#3**) must be in the **Vertical** position as shown in **Detail B** before adhering Mounting Bracket to the pole.

4. Install self-drilling screw using 5/16" Hex Socket Driver and cordless drill. When 5/16" Hex Driver makes contact with Mounting Bracket finish tightening screw with Philips Screwdriver. Do not over tighten. See **Detail C**.
5. If self-drilling screw is not used Mounting Bracket must be clamped in place for 24 hours before attaching Ball Holder.
6. When the Mounting Bracket is completely adhered to the pole, attach the Ball holder assembly with two Screws (**#4**). See **Figure 2**.

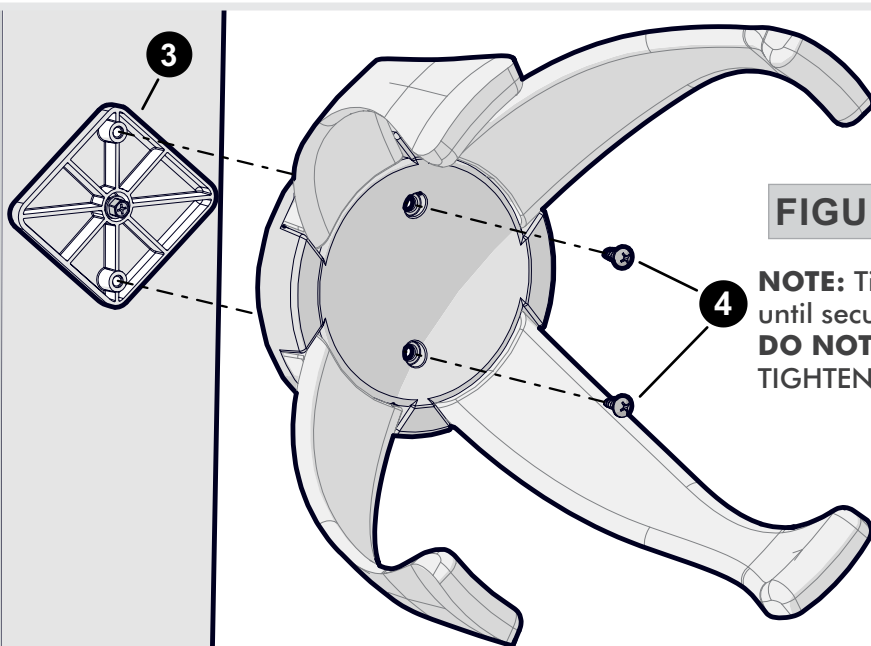
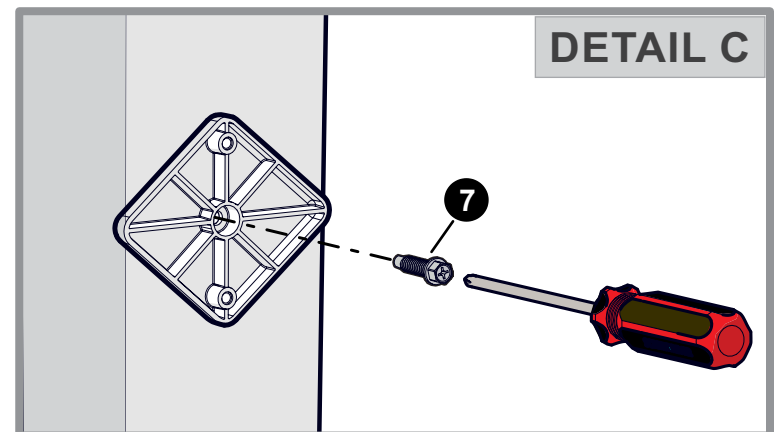
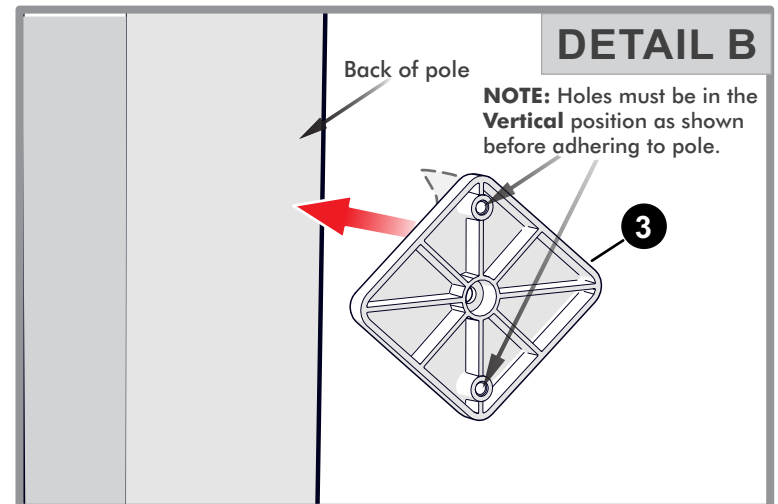
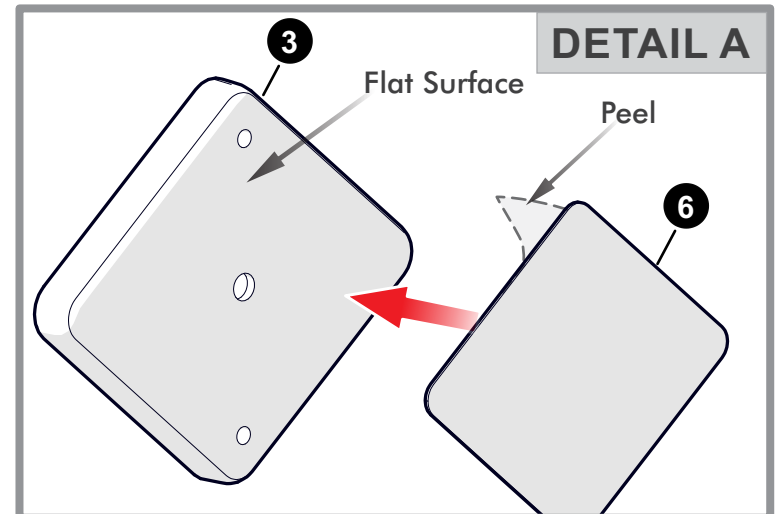

FIGURE 2

NOTE: Tighten until secure, but **DO NOT OVER-TIGHTEN**.





If installing to the back of a **basketball pole** go back to **Step 2 on page 3**. If mounting to a **Wall** continue on this page.

NOTE:

If you are mounting the Ball holder to a wall you will need to purchase either a drywall **or** masonry wall mounting kit depending on the wall you have. The kit will need an anchor for a #10 phillips head screw.

2. Follow the manufacturer's instructions on installing the anchor and then proceed to **step 3**.
3. Attach Mounting Bracket (**#3**) to the wall using Screw (**#5**) as shown in **Detail A**. The **flat surface** of the bracket must be facing the wall.

NOTE: Holes in the Mounting Bracket (**#3**) must be in the **Vertical** position as shown in **Detail A** before attaching Mounting Bracket to the wall.

4. Attach the Ball holder assembly to the Mounting Bracket with two Screws (**#4**). See **Figure 3**.

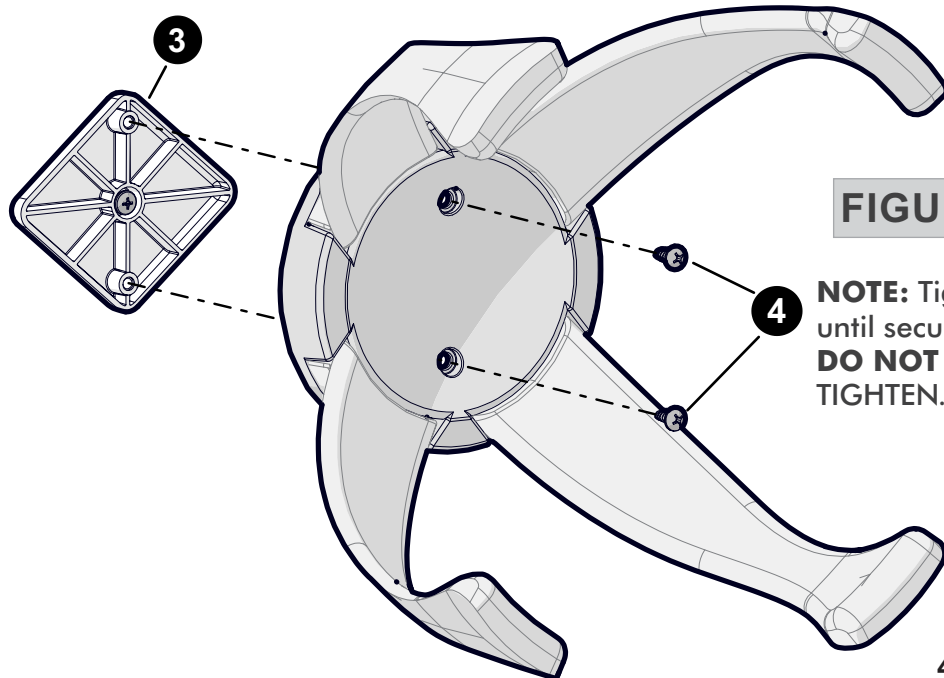

FIGURE 3

NOTE: Tighten until secure, but **DO NOT OVER-TIGHTEN**.

HARDWARE NEEDED



#8 X .375 Phillips Head
Trilobular Screw
1B-7225-00
QTY. 2

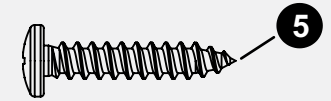

#10 X 1.0 Phillips screw
1B-7226-00
QTY. 1

TOOL NEEDED



Phillips

DETAIL A

