



Pro Grade Flashing Tape Instructions



Window Flashing Application_Method A

For windows with perimeter mounting flanges (nail fins) when the water-resistive barrier (WRB) is installed after the window installation.

Please see General Installation Notes on the Technical Data Sheet for more information on the handling of FrogTape™ Pro Grade Flashing Tape. The following illustrations detail installation procedures according to Method A from ASTM E2112-19 Standard Practice for Installation of Exterior Windows, Doors and Skylights using FrogTape Pro Grade Flashing Tapes. Method A is recommended when the water-resistive barrier (WRB) is to be applied after the window installation. Method A is jamb flashing applied over the window frame using WRB. Please reference ASTM E2112-19 Standard Practice for Installation of Exterior Windows, Doors and Skylights for additional details and installation methods applicable to the specific construction of the structure. Figure 1 shows the flashing sequence.

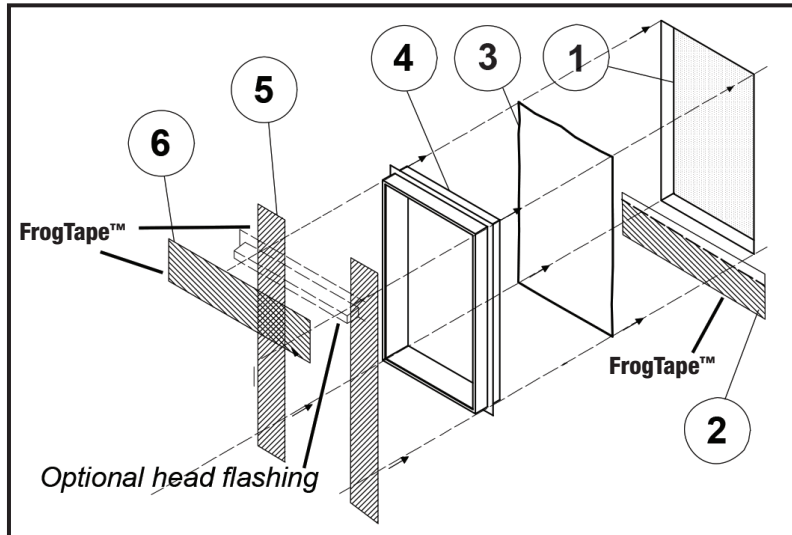

Figure 1 Flashing sequence steps.

Step 1. Prepare rough opening and surrounding wall surface. Surfaces should be clean, dry and smooth. The rough opening should not have any gaps, sharp edges or protrusions. There should be no voids, damaged or unsupported areas. Any damage should be repaired prior to installation. (see Figure 2).

Figure 2 Prepare rough opening.

Step 2. Precut a length of FrogTape™ Pro Grade Flashing Tape for the windowsill to extend a minimum of 6 in beyond the prepared rough opening at both jambs. It is recommended that the 6 in, 9 in and 12 in widths of FrogTape Pro Grade Flashing Tape be used for flashing windowsills. These widths are made with a scored release liner so that a partial piece of release liner can be removed. Remove the top portion of the release liner. Keep lower portion of release liner on the FrogTape™ Pro Grade Flashing Tape to be removed later.

Apply the adhesive exposed portion of the FrogTape™ Pro Grade Flashing Tape across the rough opening of the sill leaving the remaining release liner in place (see Figure 3). Use a roller to apply sufficient pressure along the entire surface of the tape to ensure adhesion and a continuous seal, eliminating any wrinkles, creases or trapped air beneath the tape.

Figure 3 Apply sill flashing.

Step 3. Apply sealant around perimeter of the prepared rough opening or to backside of window fin at top, sides and bottom (see Figure 4).

Figure 4 Apply perimeter sealant.

Step 4. Install window in prepared rough opening (see Figure 5).

Figure 5 Install window into flashing opening.

Step 5. Precut FrogTape Pro Grade Flashing Tape for the jambs to extend a minimum of 6 in above and below the prepared rough opening. Peel off release liner and adhere FrogTape Pro Grade Flashing Tape over the jamb fins and over top of FrogTape Pro Grade Flashing Tape (see Figure 6). Use a roller to apply sufficient pressure along the entire surface of the tape to ensure adhesion and a continuous seal, eliminating any wrinkles, creases or trapped air beneath the tape.

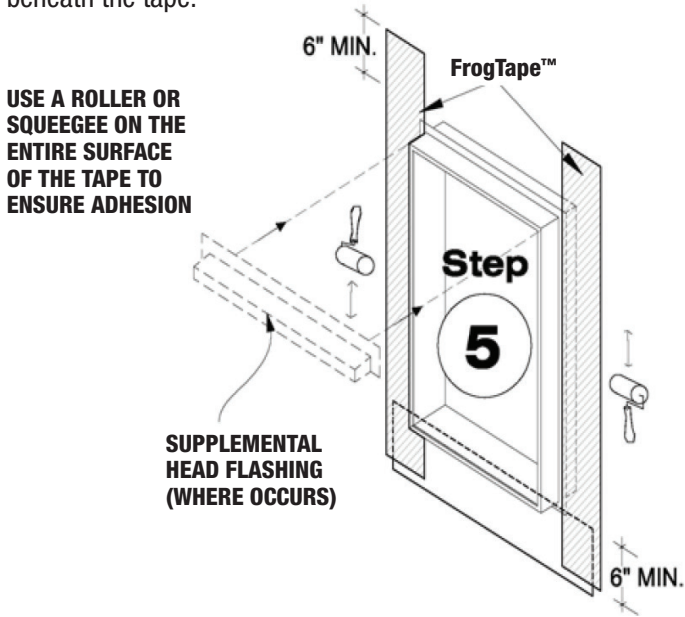

Figure 6 Apply jamb flashing.

Step 6. Precut FrogTape Pro Grade Flashing Tape for the window header to extend a minimum of 6 in beyond the jambs of the prepared rough opening. Peel off release liner and adhere FrogTape Pro Grade Flashing Tape over window fin and wall surface. Install supplemental head flashing (where applicable) with a strip of FrogTape Pro Grade Flashing Tape over the top leg (see Figure 7). Use a roller to apply sufficient pressure along the entire surface of the tape to ensure adhesion and a continuous seal, eliminating any wrinkles, creases or trapped air beneath the tape.

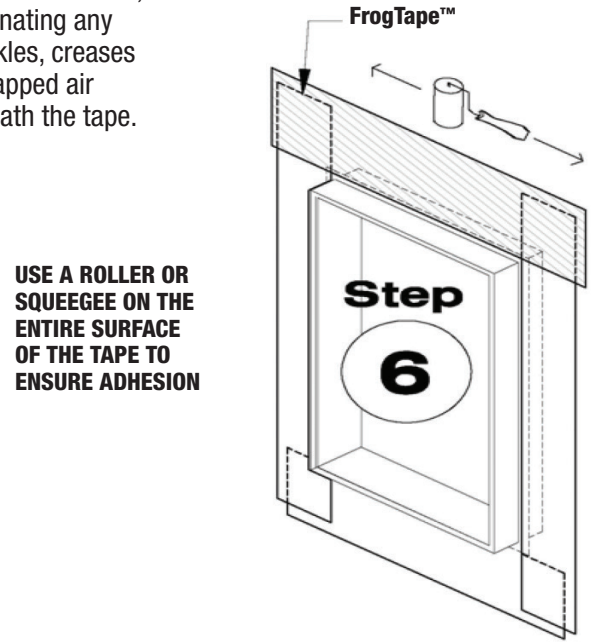

Figure 7 Apply head flashing.

Step 7. Install WRB shingle fashion from bottom of wall to top. Insert WRB under the strip of FrogTape Pro Grade Flashing Tape applied to the windowsill. Peel off remaining release liner from FrogTape Pro Grade Flashing Tape and adhere to WRB. Seal edges of WRB to FrogTape Pro Grade Flashing Tape along the window jambs and head (see Figure 8).

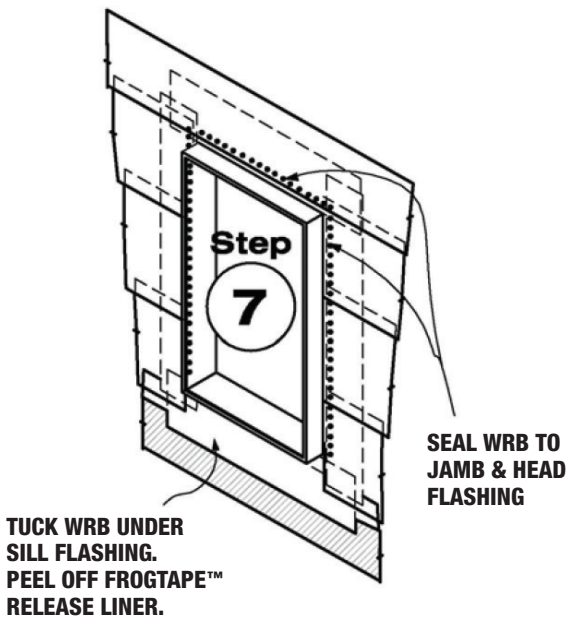

Figure 8 Install WRB and seal around perimeter.

Step 8. Install trim and/or exterior wall cladding around perimeter of window. Seal perimeter joints per the recommendations of the cladding and window manufacturers (see Figure 9).

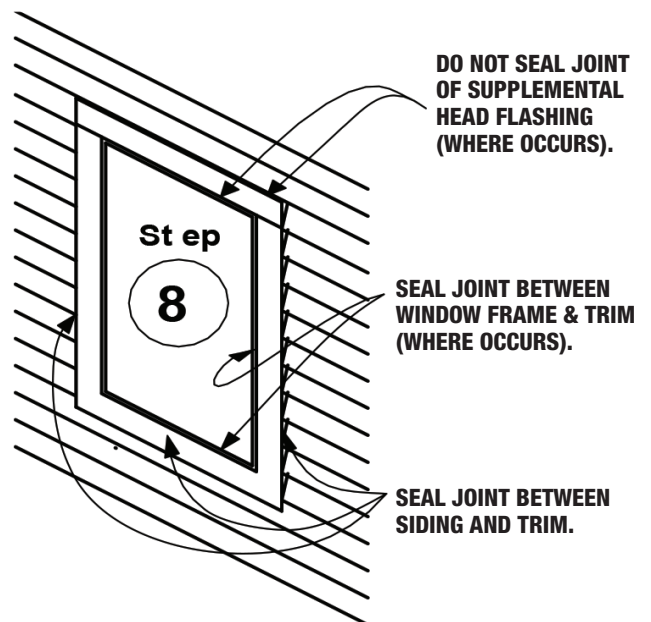

Figure 9 Install cladding.



Window Flashing Application Method A1

For windows with perimeter mounting flanges (nail fins) when the water-resistive barrier (WRB) is applied prior to window installation.

Please see General Installation Notes on the Technical Data Sheet for more information on the handling of FrogTape™ Pro Grade Flashing Tape. The following illustrations detail installation procedures according to Method A1 from ASTM E2112-19 Standard Practice for Installation of Exterior Windows, Doors and Skylights using FrogTape Pro Grade Flashing Tapes. Method A1 is for recommended when the water-resistive barrier (WRB) is installed prior to the window installation. Please reference ASTM E2112-19 Standard Practice for Installation of Exterior Windows, Doors and Skylights for additional details and installation methods applicable to the specific construction of the structure. Figure 1 shows the flashing sequence.

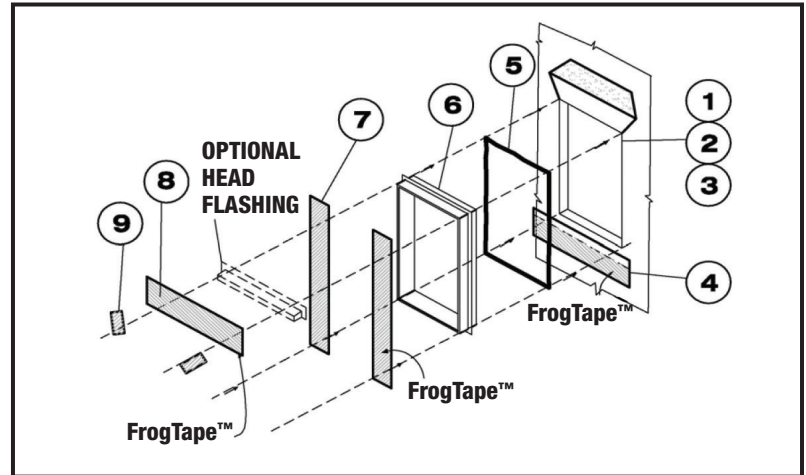

Figure 1 Flashing sequence steps.

Step 1. Prepare rough opening and surrounding wall surface. Surfaces should be clean, dry and smooth. The rough opening should not have any gaps, sharp edges or protrusions. There should be no voids, damaged or unsupported areas. Any damage should be repaired prior to installation. (see Figure 2).

Figure 2 Prepare rough opening.

Step 2. Apply the continuous WRB across prepared rough opening. Cut WRB at prepared rough opening in modified T-pattern. Fold WRB into prepared rough opening at sides and bottom (see Figure 3).

Figure 3 Install WRB and cut at opening.

Step 3. Cut slits in the WRB diagonally from the top of opening corners to a distance equal to just more than the width of jamb/head flashing tape used. Fold flap of WRB above opening head and temporarily tape in place (see Figure 4).

Figure 4 Cut head flap of WRB and fold up.

Step 4. Precut a length of FrogTape Pro Grade Flashing Tape for the windowsill to extend a minimum of 6 in beyond the prepared rough opening at both jambs. It is recommended that the 6 in, 9 in and 12 in widths of FrogTape Pro Grade Flashing Tape be used for flashing windowsills. These widths are made with a scored release liner so that a partial piece of release liner can be removed. Remove the top portion of the release liner. Keep lower portion of release liner on the FrogTape Pro Grade Flashing Tape – to be removed later. Apply the adhesive exposed portion of the Pro Grade Flashing Tape across the prepared rough opening of the sill leaving the remaining release liner in place (see Figure 5). Use a roller to apply sufficient pressure along the entire surface of the tape to ensure adhesion and a continuous seal, eliminating any wrinkles, creases or trapped air beneath the tape.

USE A ROLLER OR SQUEEGEE ON THE ENTIRE SURFACE OF THE TAPE TO ENSURE ADHESION

Figure 5 Apply sill flashing.

Step 5. Apply sealant around perimeter of the prepared rough opening or to backside of window fin at top, sides and bottom (see Figure 6).



Figure 6 Apply perimeter sealant.

Step 6. Install Window in prepared rough opening (see Figure 7).

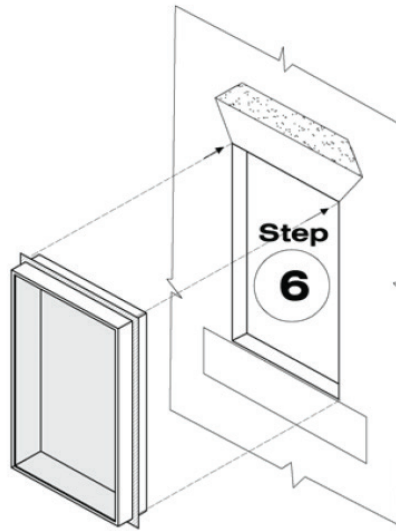

Figure 7 Install window into flashed opening.

Step 7. Precut FrogTape Pro Grade Flashing Tape for the jambs to extend a minimum of 6 in above and below the prepared rough opening. Peel off release liner and adhere FrogTape Pro Grade Flashing Tape over the jamb mounting flanges (aka nail fins) and over the top of sill flashing (see Figure 8). Use a roller to apply sufficient pressure along the entire surface of the tape to ensure adhesion and a continuous seal, eliminating any wrinkles, creases or trapped air beneath the tape.

USE A ROLLER OR SQUEEGEE ON THE ENTIRE SURFACE OF THE TAPE TO ENSURE ADHESION

SUPPLEMENTAL PREFORMED HEAD FLASHING (WHERE OCCURS)

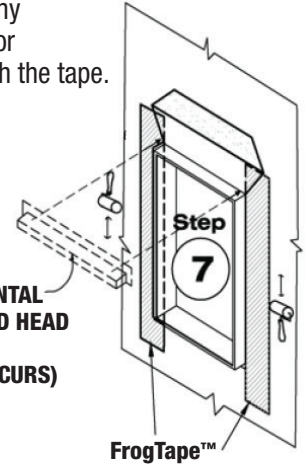

Figure 8 Apply jamb flashing.

Step 8. Precut FrogTape Pro Grade Flashing Tape for the window header to extend a minimum of 6 in beyond the jambs of the prepared rough opening. Peel off release liner and adhere FrogTape Pro Grade Flashing Tape over window mounting flange (nailing fin) and wall surface substrate. Install supplemental head flashing (where applicable) with a strip of FrogTape Pro Grade Flashing Tape over the top leg (see Figure 9). Use a roller to apply sufficient pressure along the entire surface of the tape to ensure adhesion and a continuous seal, eliminating any wrinkles, creases or trapped air beneath the tape.

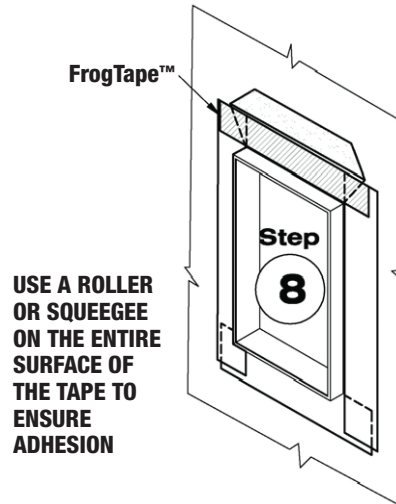

Figure 9 Apply perimeter sealant.

Step 9. Fold down flap of WRB at head over FrogTape Pro Grade Flashing Tape. Seal bottom of WRB flap with flashing tape along full length of window head. Install WRB sheathing tape or FrogTape Pro Grade Flashing Tape over diagonal cuts of the WRB (see Figure 10).

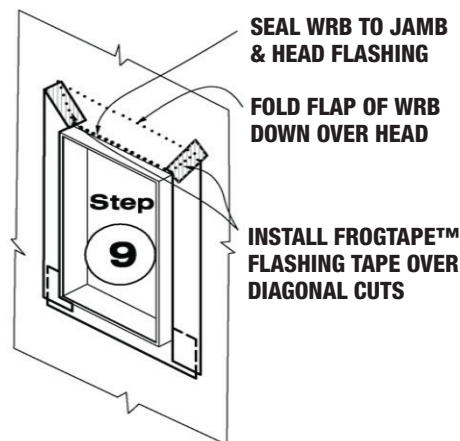

Figure 10 Unfold head flap, seal, and tape in place.

Step 10. Install trim and/or exterior wall cladding around perimeter of window. Seal perimeter joints per the recommendations of the cladding and window manufacturers (see Figure 11).

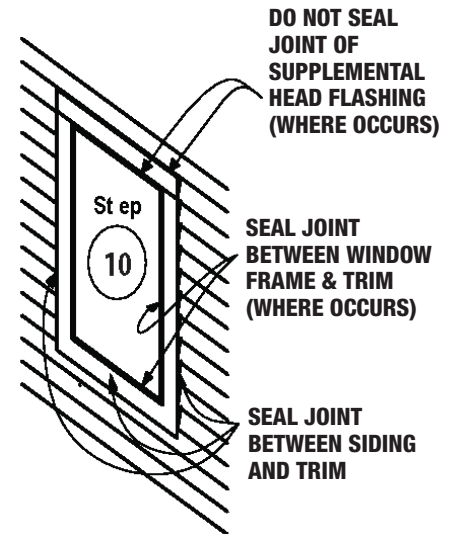

Figure 11 Install cladding.



Window Flashing Application_Method SAF

For windows with perimeter mounting flanges (nail fins) when the water resistive barrier will be applied after the window installation. This method applies the self-adhering flashing (SAF) under and over the nail fins providing an additional layer of waterproofing protection.

Please see General Installation Notes on the Technical Data Sheet for more information on the handling of FrogTape™ Pro Grade Flashing Tape. The following illustrations detail installation procedures that modify the methods described in ASTM E2112-19 Standard Practice for Installation of Exterior Windows and Skylights. This method combines features of ASTM Method A and Method B flashing under and over the fin of the frame. A strip of FrogTape™ Pro Grade Flashing Tape is substituted for the bead of perimeter sealant applied under the window fins in the ASTM methods. Please reference ASTM E2112-19 Standard Practice for Installation of Exterior Windows, Doors and Skylights for additional details and installation methods applicable to the specific construction of the structure.

Figure 1 shows the flashing sequence.

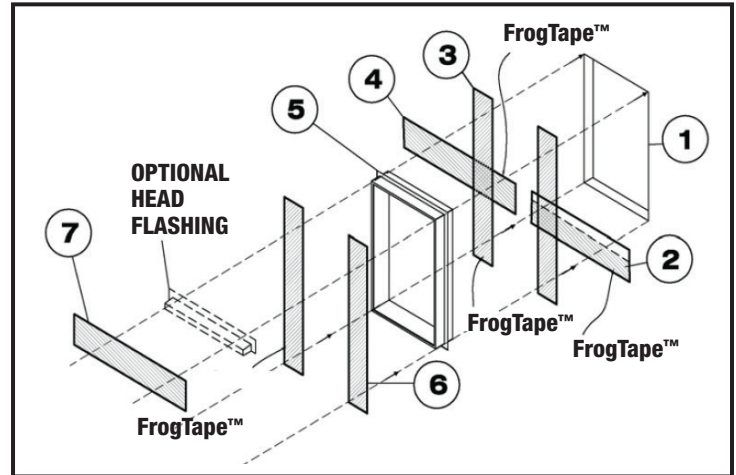

Figure 1 Flashing sequence steps.

Step 1. Prepare rough opening and surrounding wall surface. Surfaces should be clean, dry and smooth. The rough opening should not have any gaps, sharp edges or protrusions. There should be no voids, damaged or unsupported areas. Any damage should be repaired prior to installation (see Figure 2).

Figure 2 Prepare rough opening.

Step 2. Precut a length of FrogTape Pro Grade Flashing Tape for the windowsill to extend a minimum of 6 in beyond the prepared rough opening at both jamb. It is recommended that the 6 in, 9 in and 12 in widths of FrogTape Pro Grade Flashing Tape be used for flashing windowsills. These widths are made with a scored release liner so that a partial piece of release liner can be removed. Remove the top portion of the release liner. Keep lower portion of release liner on the FrogTape Pro Grade Flashing Tape – to be removed later. Apply the adhesive exposed portion of the FrogTape Pro Grade Flashing Tape across the prepared rough opening of the sill leaving the remaining release liner in place (see Figure 3). Use a roller to apply sufficient pressure along the entire surface of the tape to ensure adhesion and a continuous seal, eliminating any wrinkles, creases or trapped air beneath the tape.

Figure 3 Apply sill flashing.

Step 3. Precut FrogTape Pro Grade Flashing Tape for the jamba to extend a minimum of 6 in above and below the prepared rough opening. Peel off release liner and adhere FrogTape Pro Grade Flashing Tape over the jamb fins and over the top of FrogTape Pro Grade Flashing Tape (see Figure 4). Use a roller on the entire surface of the tape to ensure adhesion.

Figure 4 Apply jamb flashing.

Step 4. Precut FrogTape Pro Grade Flashing Tape for the window header to extend a minimum of 6 in beyond the jamb of the prepared rough opening. Peel off release liner and adhere FrogTape Pro Grade Flashing Tape over head opening and jamb flashings (see Figure 5). Use a roller to apply sufficient pressure along the entire surface of the tape to ensure adhesion and a continuous seal, eliminating any wrinkles, creases or trapped air beneath the tape.

Figure 5 Apply head flashing.

Step 5. Install window in opening (see Figure 6).

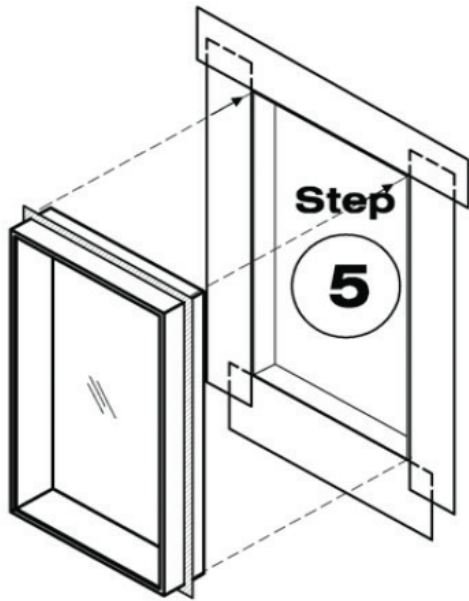

Figure 6 Install window into flashed opening.

Step 6. Precut FrogTape Pro Grade Flashing Tape for the jambs to extend a minimum of 6 in above and below the prepared rough opening (see Figure 7).

USE A ROLLER OR SQUEEGEE ON THE ENTIRE SURFACE OF THE TAPE TO ENSURE ADHESION

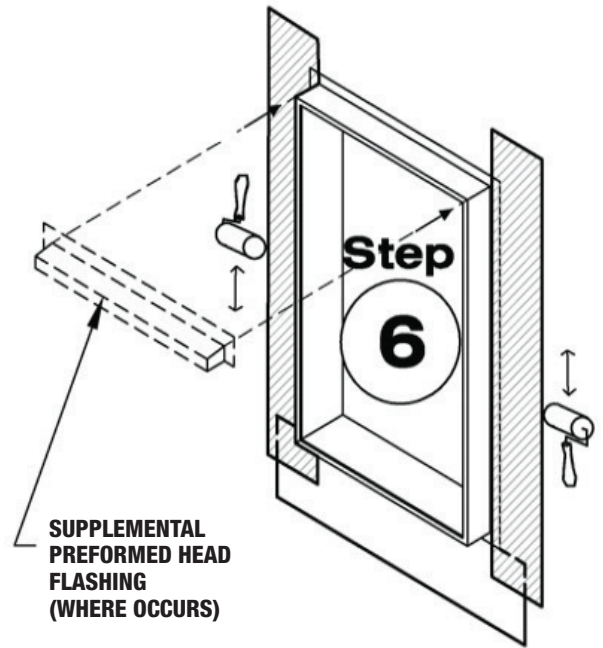

Figure 7 Apply jamb flashing.

Step 7. Precut FrogTape Pro Grade Flashing Tape for the window header to extend a minimum of 6 in beyond the jambs of the prepared rough opening. Peel off release liner and adhere over window fin (see Figure 8). Use a roller to apply sufficient pressure along the entire surface of the tape to ensure adhesion and a continuous seal, eliminating any wrinkles, creases or trapped air beneath the tape.

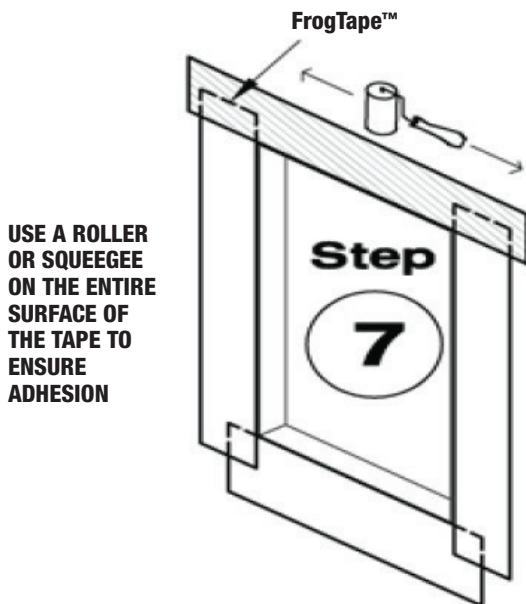

Figure 8 Apply head flashing.

Step 8. Install water-resistant barrier (WRB) shingle fashion from bottom of wall to top. Integrate sill flashing by inserting WRB under sill flashing. Peel off remaining release liner from FrogTape Pro Grade Flashing Tape and adhere to WRB. Seal edges of WRB to window jamb and head (see Figure 9).

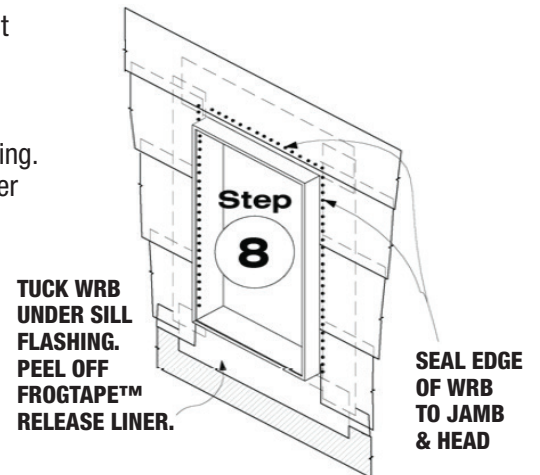

Figure 9 Install WRB and seal around perimeter.

Step 9. Install trim and/or exterior wall cladding around perimeter of window. Seal perimeter joints per the recommendations of the cladding and window manufacturers (see Figure 9).

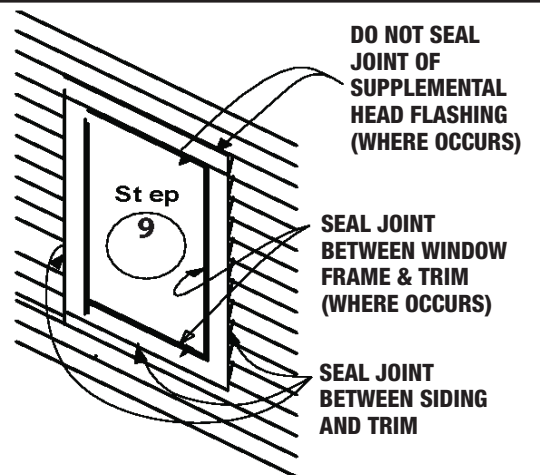

Figure 10 Install cladding.

