

**User's Manual**  
**10-INCH DUAL VOICE COIL**  
**SUBWOOFER**  
**CW105DVC**

**CHAOS WIRE**  
SERIES

**CW105DVC**  
10-INCH DUAL VOICE COIL  
SUBWOOFER

03.2010



tech support: [www.bossaudio.com/support](http://www.bossaudio.com/support)

BOSS Audio Systems  
3451 Lunar Court • Oxnard, CA 93030

[www.bossaudio.com](http://www.bossaudio.com)

800.999.1236

**BOSS**<sup>®</sup>  
**AUDIO SYSTEMS**

# Recommended Enclosures

Please note : Our recommended box volumes are given for internal air requirements.

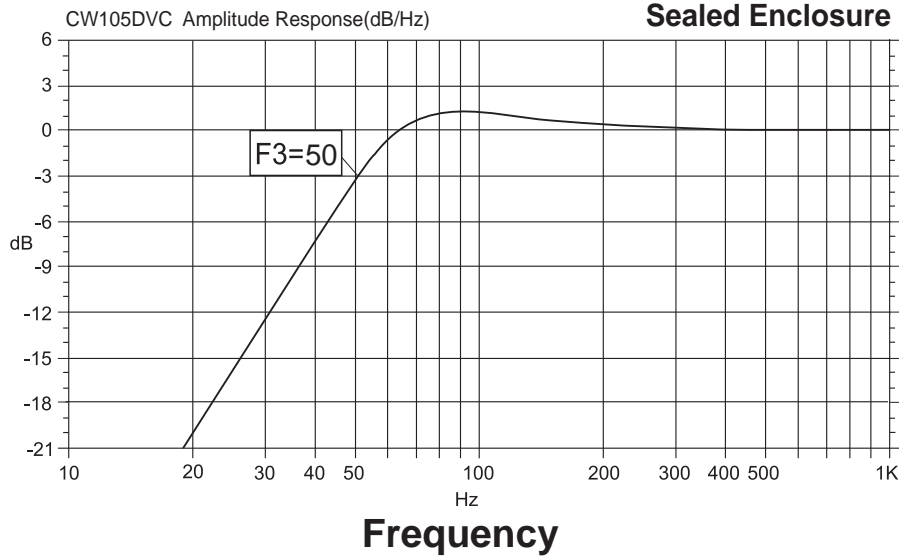

**Sealed Enclosure**

**Box Volume : 0.5 Cu Ft**

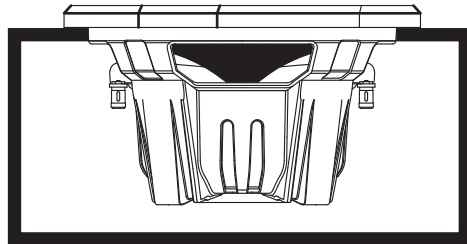

Box is given as internal air volume including driver displacement

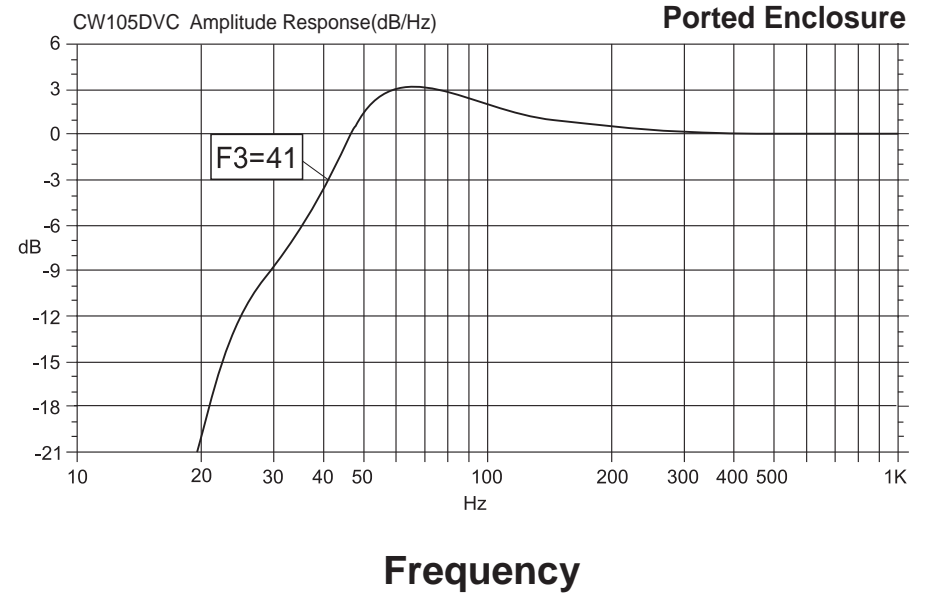

**Ported Enclosure**

**Box Volume : 0.8 Cu Ft**

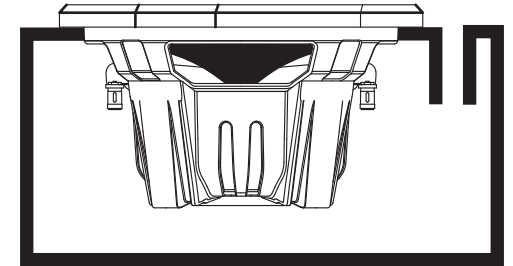

Box is given as internal air volume including driver displacement

Port Frequency : 39 Hz  
 Port Diameter : 3 Inches  
 Port Length : 10 Inches

# Product Specifications

Speaker Impedance	table	2ohms	4 ohms	8 ohms
Free Air Resonance	(Fs)	35	35	35
Total Q Driver @ FS including all resistance's	(Qts)	0.558	0.871	0.554
Q of the Driver @ FS including non electrical resistance only	(Qms)	5.984	5.284	6.279
Q of the Driver @ FS including electrical resistance only	(Qes)	0.616	1.043	0.607
The Driver's compliance expressed as an equivalent	(Vas)	1.098	1.082	1.236
Volume of all (cubic Ft.)				
The Driver's linear displacement (inches)	(Xmax)	0.246	0.246	0.246
The DC resistance of the driver's twin voice coils(ohms)	(Re)	1.8	3.6	7.2
Thermal Power rating of Driver (R.M.S./Peak)	(Pe)	900W/1800W	900W/1800W	900W/1800W
The Driver's sensitivity (dB)	(Sens)	94	94	94

# Calculating Enclosures

It is difficult to give exact box dimensions that are universal for all cars and trucks. It is for this reason that you must be able to calculate the space in which you have available in order to achieve the proper air volume required.

It is recommended to build your enclosure from 3/4" thick MDF (medium density fiberboard). Make sure the enclosure is sealed air tight.

## Calculating External Volume

- 1) To calculate box volume, measure the outside Width x Height x Depth of the enclosure. Example 12" x 14" x 9" = 1512"
- 2) Next you must convert cubic inches into cubic feet. To do this, You must divide the cubic inch total by 1728". Example 1512 ÷ 1728= .875 Cubic feet

## Calculating Internal Volume

- 1) To calculate the internal (net) volume of the above box you must first multiply the thickness of the wood you are using by Two (2) Example; 3/4" x 2"=1.5"
- 2) Next Subtract 1.5 from each of the outside measurements of the box.  
Width 12-1.5=10.5 Height 14-1.5=12.5 Depth 9-1.5=7.5
- 3) Multiply the new totals (H x W x D) Example : 10.5 x 12.5 x 7.5=984.375
- 4) Next you must convert cubic inches into cubic feet.To do this,you must divide the cubic inch total by 1728" Example 984.375 ÷ 1728= .5696 Cubic feet

# Wiring

Please take every precaution to wire your DVC woofers for the correct impedance

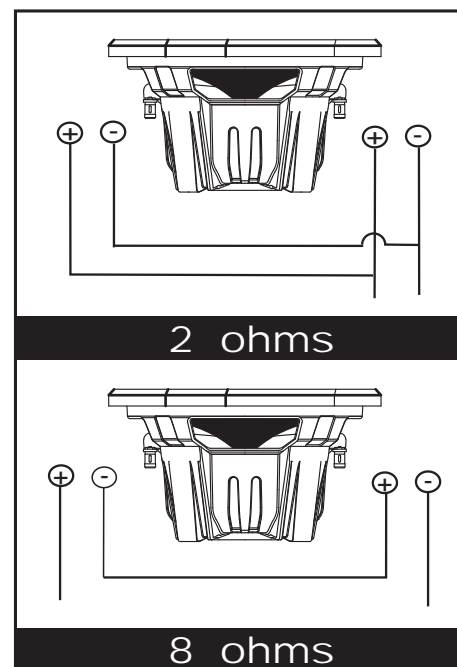

# 10" (254mm) Subwoofer

(900 Watts RMS Sealed Enclosure)

- 10" (254mm) CUSTOM TOOLED HIGH EFFICIENCY POLY INJECTION CONE
- BUTYL RUBBER SURROUND
- DUAL 2.5" (64mm) HIGH TEMPERATURE KAPTON VOICE COIL
- 1800 WATTS PEAK/900 WATTS RMS
- FREQUENCY RESPONSE: 35 Hz-2.2 KHz
- SENSITIVITY: 94dB (1 WATT/1 METER)
- IMPEDANCE: DUAL 4 OHMS
- MOUNTING DEPTH: 5-5/8" (143mm)
- MOUNTING DIAMETER: 9-5/16" (236mm)