

# ONE COLL. SIDE TABLE ASSEMBLY INSTRUCTIONS

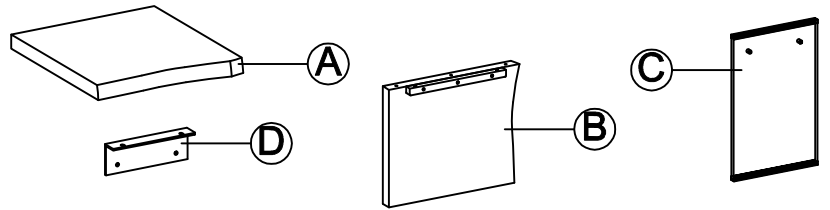

## PARTS PACKING CONFIGURATIONS

- A.TOP 1PC
- B.WOOD SIDE PANEL 1PC
- C.GLASS SIDE PANEL 1PC
- D.L-BRACKET 2PCS



### HARDWARE KIT PACKED IN BOX

NO.	DESCRIPTION	IMAGE	Q'TY
1	ALLEN BOLT (5/16"x1-1/2")		2 PCS
2	ALLEN BOLT (5/16"x1")		4 PCS
3	LOCK WASHER (5/16")		6 PCS
4	FLAT WASHER (5/16")		6 PCS
5	ALLEN KEY (5mm)		2 PCS
6	CONNECTOR CAP		2 PCS
7	CONNECTOR BOLT (M8x15mm)		2 PCS
8	PLASTIC WASHER (25x2mm)		4 PCS
9	WOOD DOWEL(8x30mm)		3 PCS

### FULLY ASSEMBLED

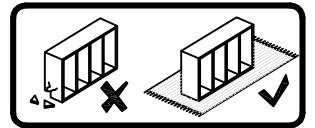
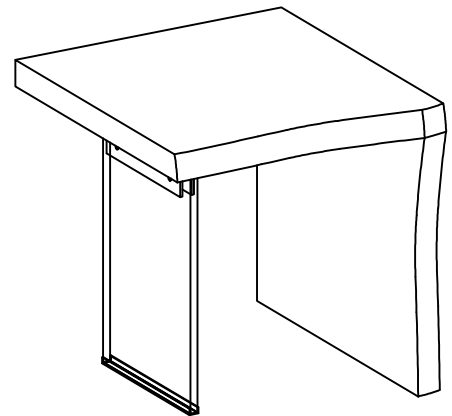

### Step 1:

- #5 (2)
- #6 (2)
- #7 (2)
- #8 (4)

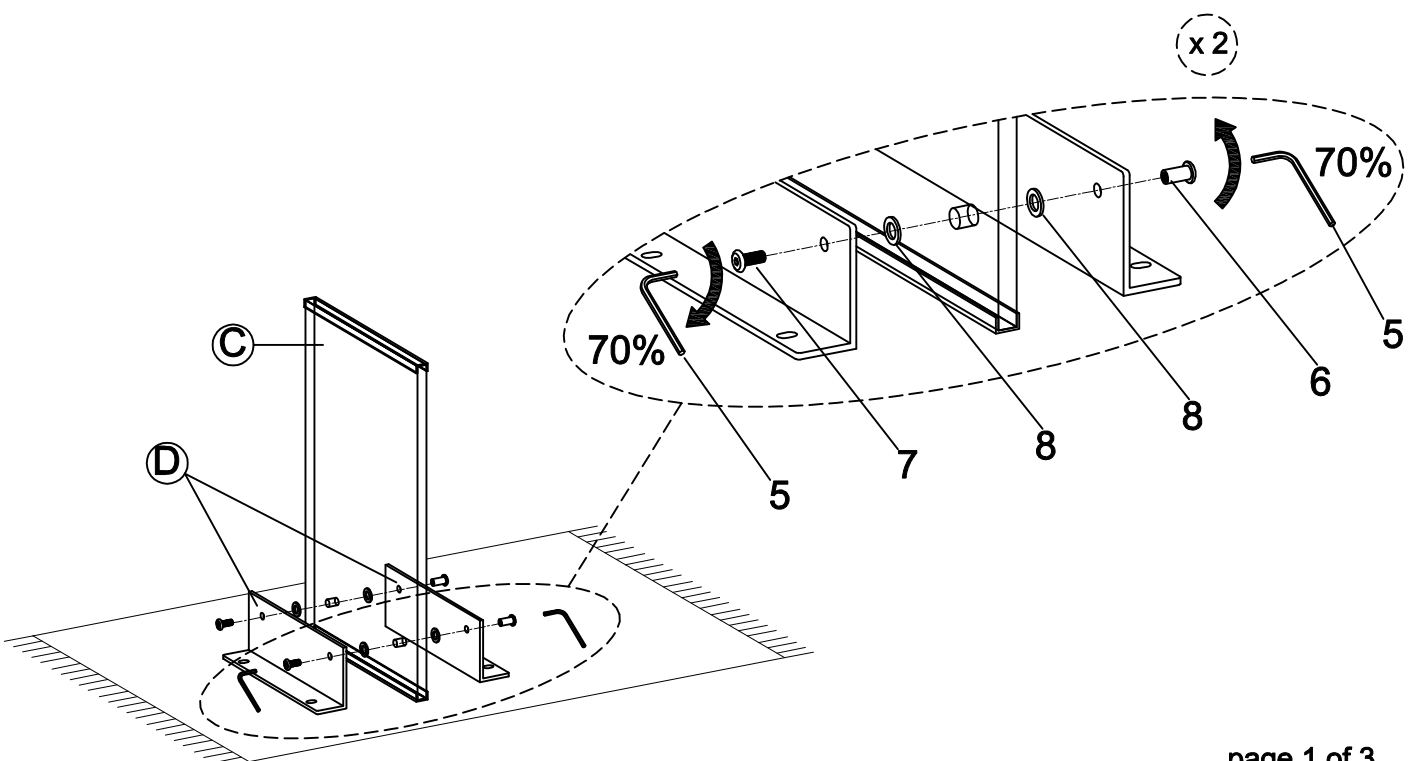

# ONE COLL. SIDE TABLE ASSEMBLY INSTRUCTIONS



## Step 2:

#1 (2)	#2 (4)	#3 (6)
#4 (6)	#5 (1)	#9 (3)

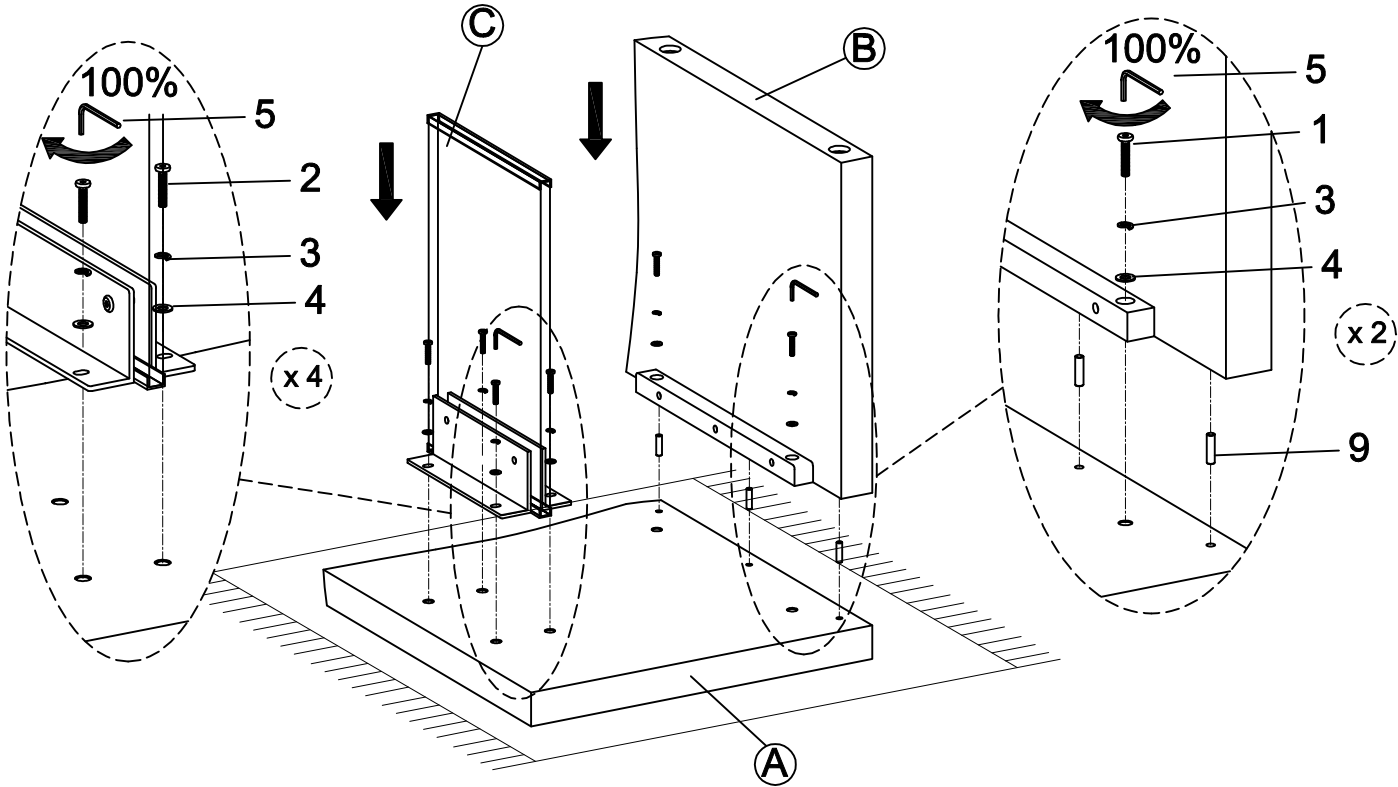

## Step 3:

#5 (2)
--------

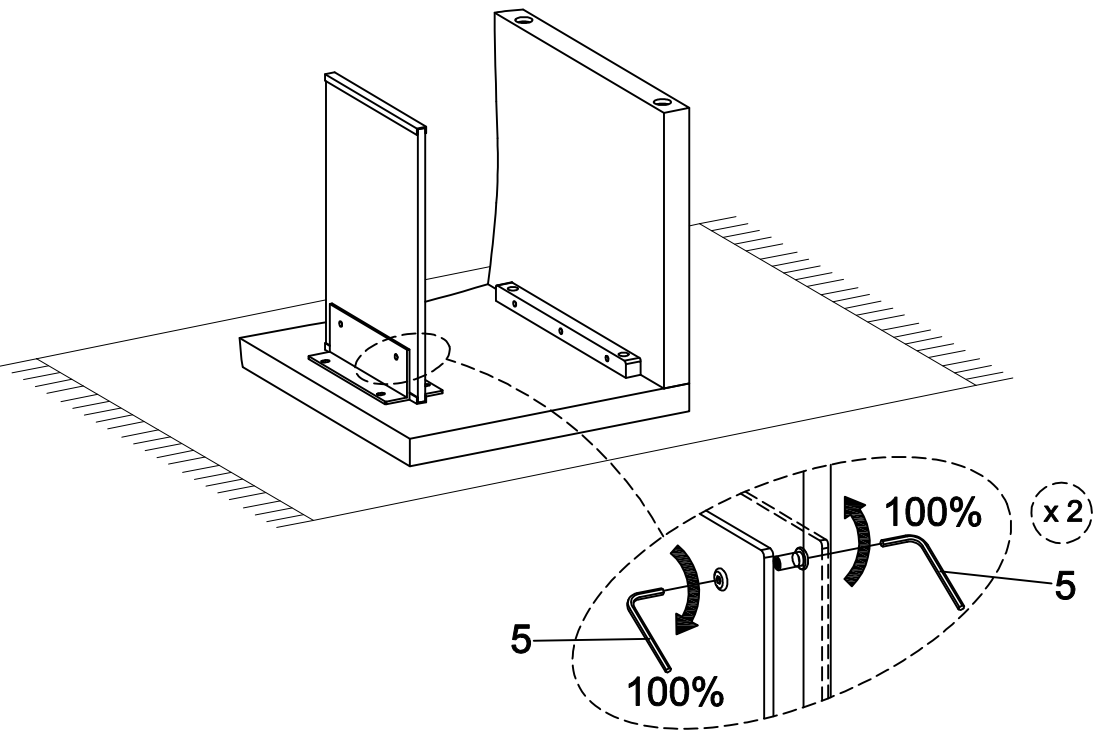

# ONE COLL. SIDE TABLE ASSEMBLY INSTRUCTIONS



Step 4:

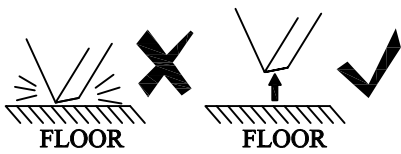
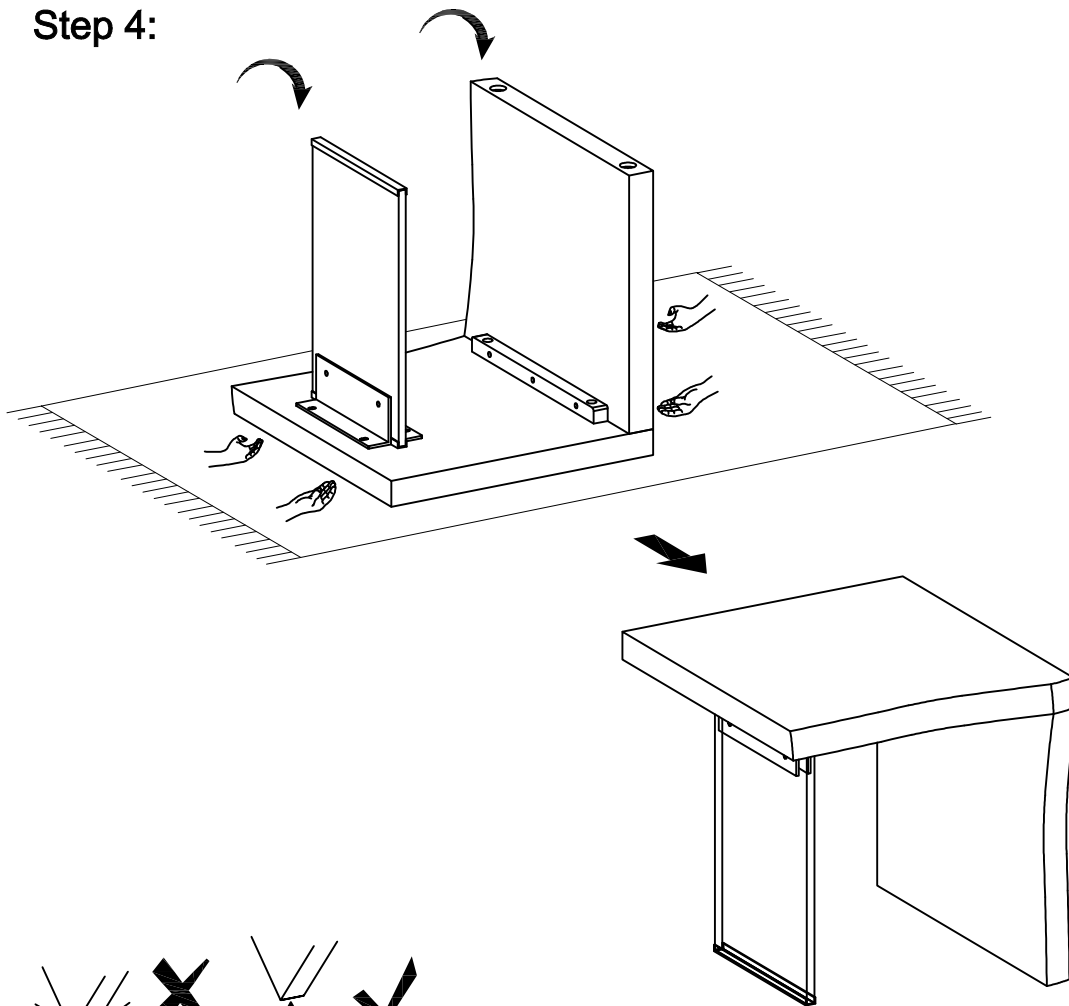

ASSEMBLY COMPLETE

