



TEST REPORT

TEST OF A NON-CATALYTIC WOOD HEATER FOR EMISSIONS AND EFFICIENCY  
PER EPA METHODS ALT-125, ASTM E2515, ASTM E3053 and CSA B415.1,

Client:

**Wolf Steel Ltd.**

24 Napoleon Road, Barrie,  
Ont. L4M 0G8  
Model Name: EPI3

Attention: Rafael Sanchez

TESTED BY:

Services Polytests inc.  
695-B Gaudette  
St-jean-sur-Richelieu, QC, J3B 7S7

TEST DATES: April 1<sup>st</sup> and 3<sup>rd</sup> 2019

REPORT DATE: April 15<sup>th</sup> 2019

Revision 1: June 17<sup>th</sup> 2019

Revision 2: November 25<sup>th</sup> 2020

Revision 3: December 8<sup>th</sup> 2020

Project number: PI-20190

All services undertaken are subject to the following general policy: Reports are submitted for exclusive use of the clients to whom they are addressed. Their significance is subject to the adequacy and representative character of the samples and to the comprehensiveness of the tests, examinations or surveys made. This document may not be reproduced except in its entirety without the written permission from Services Polytests. Services Polytests have not been involved in any R&D design consulting regarding this unit as requested by the NSPS.

Handwritten signatures of Sebastien Boulais and Maxime Martin in black ink.

Tested:  
Sebastien Boulais, Maxime Martin

Handwritten signature of Danick Power in black ink.

written by:  
Danick Power, P. Eng

Verified by third party certifier (CSA):

## SUMMARY

1	Introduction .....	4
1.1	General.....	4
1.2	Test unit information .....	4
1.3	Results.....	4
1.4	Pretest information.....	5
2	Summary of test results .....	5
2.1	Model identification.....	5
2.2	Laboratory information.....	5
2.3	Test condition Summary .....	6
2.4	Test run results summary .....	7
2.5	Weighted average summary .....	8
2.6	Weighted average Final results.....	8
2.7	Test facility conditions .....	8
2.8	Dilution tunnel flow rate measurements and sampling data (ASTM E2515).....	9
2.9	Dilution tunnel dual train precision .....	9
3	Process description .....	10
3.1	Discussion .....	10
3.2	Unit dimensions .....	10
3.3	Air supply system .....	11
3.4	operation during test .....	12
3.5	Start-up operation .....	12
3.6	Sampling locations .....	12
3.7	Drawings .....	12
3.8	Emissions efficiency testing equipment list .....	12
4	Sampling methods .....	13
4.1	Particulate sampling .....	13
5	Quality assurance .....	13
5.1	Instrument calibration .....	13
5.1.1	Gas meters.....	13
5.1.2	SCALES .....	13
5.1.3	Gas analyzers .....	13
5.2	Test method procedures.....	13
5.2.1	Leak check procedures .....	13

5.2.2	Tunnel velocity flow measurement .....	13
5.2.3	Pm sampling proportionality (ASTM E2515) .....	13

## List of revision

Revision 1: June 17<sup>th</sup> 2019, Adding Appendix 13 to the Non-CBI Report, updated Wood heater Application

Revision 2: update report to comply with ADEC requirements, mainly N-CBI report additional appendix, update comments p.12, 3.4 operation during testing.

Revision 3: Names update p.4 and molecular weight appendix 1

## List of appendixes

- APPENDIX 1: Raw data, forms and results
- APPENDIX 2: Proportionality results
- APPENDIX 3: Calibration data
- APPENDIX 4: Unit pre-burn
- APPENDIX 5: Participants
- APPENDIX 6: Drawings and specifications
- APPENDIX 7: Manual & Label
- APPENDIX 8: Photographs of test set up
- APPENDIX 9: Test load photographs
- APPENDIX 10: Laboratory Operating Procedures
- APPENDIX 11: Sample calculations
- APPENDIX 12: Volume calculations
- APPENDIX 13: Operating instruction
- APPENDIX 14: Drawing Air flow pattern
- APPENDIX 15: Application for wood stove program

# 1 INTRODUCTION

## 1.1 GENERAL

### Laboratory

- Location: Services Polytests Inc., 695-B Gaudette St-jean-sur-Richelieu QC, Canada J3B 7S7
- Elevation: 100 feet above sea level

### Test program

- Purpose: unit qualification NSPS 2020 cord wood
- Test dates: April 1<sup>st</sup> and 3<sup>rd</sup> 2019
- Test methods used:
  - Particulate emissions: ASTM E3053-17; ASTM E2515-11 methods ALT-125 as referred into 40 CFR Part 60 Subpart AAA
  - Efficiency: CSA B415.1-10

## 1.2 TEST UNIT INFORMATION

### General EPI3

- Manufacturer: Wolf Steel ltd
- Product type: wood heater
- Combustion system: non-catalytic
- Unit tested: EPI3

### Particularities

- Napoleon EPI3C-1 - Contemporary Fireplace Insert, Cast Iron Surround, Black
- Napoleon EPI3T-1 - Traditional Fireplace Insert, Cast Iron Surround, Black
- Napoleon EPI3TN-1 - Traditional Fireplace Insert, Cast Iron Surround, Porcelain Majolica Brown
- Timberwolf TI3C-1 - Identical to EPI3C-1, just Timberwolf brand
- Timberwolf TI3T-1 - Identical to EPI3T-1, just Timberwolf brand
- Timberwolf TI3TN-1 - Identical to EPI3TN-1, just Timberwolf brand

### In Summary:

All 3 models are built from the same firebox configuration. All primary and secondary airflows are exactly the same at that point where they enter the unit. The viewing area and latching mechanism is the same for all door configurations. The EPI3 is offered with 3 different cast iron surrounds (Contemporary, Traditional black or Traditional majolica brown).

## 1.3 RESULTS

### Emission results obtained

- Weighted Average Emissions Rate: 1.21 g/hr
- Weighted Average Overall Efficiency: 71.6 %

Conformity: NSPS Phase 2020 cord wood.

## 1.4 PRETEST INFORMATION

Unit condition: The unit was received by carrier in January 2019 in good condition. The 50hrs of aging was done by Polytests Services.

Set up

- Venting system type: diameter 6-inch steel pipe and insulated chimney
- System height from floor: 15 feet
- Particularities: Optional convection fan can be provided with the heater

## 2 SUMMARY OF TEST RESULTS

### 2.1 MODEL IDENTIFICATION

Model name number	EPI3
Manufacturer	Wolf Steel ltd
address	24 Napoleon Road, Barrie, Ont. L4M 0G8
appliance category	wood stove
Usable Firebox Volume - ft3	1,79
Catalytic/Non-Cat	Non-Cat
convection air fan (no, standard, Optional)	optional

### 2.2 LABORATORY INFORMATION

Testing laboratory	Polytests Services
address	695-B Gaudette, St-jean-sur-richelieu
ISO/ Accreditation info	17025
Dates tested	April1st and 3 <sup>rd</sup> 2019
Test Methods / Standard	ALT-125
Dilution Tunnel Inside diameter - in	8
Filter diameter	47
Filter material	PTFE Pall

## 2.3 TEST CONDITION SUMMARY

Model Name(s) / number(s)	EPI3		
Usable firebox Volume-ft3	1.79		
Convection Air Fan (No, Standard, Optional)	OPTION		
Test runs #	1,1	1,1	2,1
Date tested	April 1 <sup>st</sup> 2019	April 1 <sup>st</sup> 2019	April 3 <sup>rd</sup> 2019
test run category (L,M,H)	H	L	M
average barometric pressure - in Hg	30,11	30,11	29,81
Max observe Ambient temp. °F	72,25	77,30	77,82
Min observe Ambient Temp °F	68,16	71,55	73,18
Max observe Filter temp °F	87,69	87,15	86,49
Run air settings			
Primary (measured up from minimum)	maximum setting	minimum setting	medium setting
Secondary (measured up from minimum)	fix	fix	fix
Convection air setting	on	off	off
Test fuel load			
Cordwood fuel species	Oak	Oak	Oak
specific Gravity (from Table 1)	0,66	0,66	0,66
Higher heating value - Btu/lb (from Annex A1)	8690	8690	8690
Nom. Test fuel piece length - in	16	16	16
Number of test fuel pieces			5
Test fuel Weight			
Kindling - as fired lb.	3,50	NA	NA
Kindling Wt. - as % of test fuel load	19,5%	NA	NA
Kindling Moisture % Db	9,0	NA	NA
Kindling Kg DB	1,46	NA	NA
SU Fuel Wt- as fired lb	5,00	NA	NA
SU Fuel wt. - as % of test fuel load	27,8%	NA	NA
SU Fuel moisture - % DB	20,0	NA	NA
SU fuel- Kg DB	1,89	NA	NA
Test Fuel Load - As Fired lb	17,95	21,42	21,58
Ave. Test Fuel Load MC % DB	20,40	20,46	23,24
Test Fuel Load - kg DB	6,76	8,07	7,94
Test fuel Loading density lb./ft3	10,03	11,97	12,06
Residual SU fuel wt. - as fired lb.	2,7	NA	NA
Residual SU fuel wt.- as % of test fuel load	15,0%	NA	NA
Test run duration - minutes	127	472	327
Test run duration - h	2,12	7,87	5,45
Test fuel load wt at the end of the test - as fired lb	1,64	0	0
total fuel burned kg Db	8,14	8,07	7,94
% test fuel load wt at end of the test	9,1%	0,0%	0,0%

## 2.4 TEST RUN RESULTS SUMMARY

Model name / number	EPI3		
Usable Firebox volume	1.79		
Convection air Fan (no, Standard, option)	OPTION		
Test runs nu.	1,1	1,2	2,2
Date tested	April 1 <sup>st</sup> 2019	April 1 <sup>st</sup> 2019	April 3 <sup>rd</sup> 2019
Test run category	H	L	M
Burn rate - Kg/hr DB	3,72	1,03	1,46
Burn rate as % of low to high Midpoint	NA	27,5%	39%
Burn duration - h	2,12	7,87	5
Heat output btu/hr	47 887	14 492	20 108
Average Dilution Tunnel Flow Rate - dscfm	304,6	318,1	337,0
Average Sample Flow Rates - dscfm			
Train 1	0,1949	0,1943	0,1940
train 2	0,1864	0,1850	0,1856
Total PM Emissions - g			
Train 1 g	6,88	5,80	3,55
train 2 g	7,52	5,25	3,17
Average	7,20	5,52	3,36
PM emission train precision %	4,45%	5,00%	5,54%
PM emission g/kg	0,88	0,68	0,42
PM emission rate g/h	3,40	0,70	0,62
Total Co Emission g	103,3	583,3	458,2
Co emission Rate g/h	63,9	74,1	84,1
1 <sup>st</sup> hour emission rate g/h	6,1	3,8	1,6
Overall Efficiency - CSA B415,1			
% HHV Basis	66,81%	73,72%	71,95%
% LHV Basis	71,89%	79,32%	77,42%



## 2.5 WEIGHTED AVERAGE SUMMARY

Model name / number	EPI3		
Usable Firebox volume	1.79		
Convection air Fan ( no, Standard, option)	OPTION		
average for each test run category	L	M	H
burn rate kg/h DB	1,03	1,46	3,72
PM Emission rate - g/h	0,70	0,62	3,40
Co emission rate - g/h	74,15	84,08	63,93
Overall Efficiency - CSA B 415,1			
% HHV Basis	73,7%	71,9%	66,8%
% LHV Basis	79,3%	77,4%	71,9%
Heat output - Btu/hr	14492	20108	47887
Category weighting	0,4	0,4	0,2

## 2.6 WEIGHTED AVERAGE FINAL RESULTS

ASTM E 3053 Weighted averages			
PM Emission Rate - g/h	1,21		
CO Emission Rate g/h	76,1		
Overall Efficiency - CSA B415,1			
% HHV Basis	71,63%		
% LHV Basis	77,07%		
Heat output range - Btu/h	14 492	to	47887
Co Arithmetic average g/min	1,23		

## 2.7 TEST FACILITY CONDITIONS

Run Number	Room Temperature		Barometric pressure		Relative humidity		Air Velocity	
	Before	After	Before	After	Before	After	Before	After
	(F)	(F)	(in.Hg)	(in.Hg)	(%)	(%)	(ft/min)	(ft/min)
1	70	69	30,06	30,15	20,6	22,6	0	0
2	69	80	29,94	29,68	24,3	26,6	0	0

## 2.8 DILUTION TUNNEL FLOW RATE MEASUREMENTS AND SAMPLING DATA (ASTM E2515)

Average dilution tunnel measurements				Sample Data			
Run Number/ test category	Burn Rate (Min)	Volumetric Flow Rate (dscf/min)	Total Temperatures (°R)	Volume sampled (DSCF)		Particulate catch (mg)	
				1	2	1	2
high Fire test	127	304,63	579,92	24,755	23,674	4,40	4,60
Low fire test	472	318,12	555,52	91,728	87,298	3,70	3,20
medium fire test	327	337,04	558,80	63,441	60,700	2,20	1,90

## 2.9 DILUTION TUNNEL DUAL TRAIN PRECISION

Run Number/ test category	Sample Ratio		Total Emission (g)		
	Train 1	Train 2	Train 1	Train 2	% Deviation
high Fire test	1562,83	1634,14	6,88	7,52	4,45%
Low fire test	1636,92	1719,98	5,80	5,25	5,00%
medium fire test	1737,22	1815,69	3,55	3,17	5,54%

## 3 PROCESS DESCRIPTION

### 3.1 DISCUSSION

The heater was received in a good shape by a carrier in January 2019. Pre-burn at medium heat draw were done as preliminary burns with cord wood at Polytests facility. The side walls of the combustion chamber are lined with Firebricks. The secondary air inlet is fixed and the primary air damper is located at the underneath the firebox. Post combustion is ensured by the secondary tubes located at the top of the firebox. Above the tubes a is a deflector made of Ceramic fiber.

### 3.2 UNIT DIMENSIONS

#### Baffle

- Location: between top of combustion chamber and hearth
- Restriction: 1 3/8 X 24 inches at the front of unit
- Dimensions: covers the hearth area minus the restriction at front
- Material: 1-inch thick vermiculite

#### Bricks

- Refractory cement 1 ¼ thick lining bottom, back and side of the firebox.

#### Flue gas exhaust

- Location: top
- Dimensions: 6 in. diameter
- Material: Steel

#### Gasket

- Door gasket - Outer: 0.5" DIA black woven fiberglass rope
- Glass gasket: 0.75" x 0.062" black woven fiberglass
- Front Seating on Firebox: 0.25" Dia. Black Woven Fiberglass Rope
- Flue Collar: 0.25" Dia. Black Woven Fiberglass Rope

#### Overall unit dimension

- Firebox dimensions: W23 ½ to 18, D= 14 ¼ H Max=12 1/8
- Usable volume: 1.79 cuft
- Overall dimension: W: 42 7/16, D= 22 ¾, H Max= 28 5/8

#### Convection fan

- The blower drawing containing its specifications is included in SUBASSEMBLIES drawings.

#### Catalyst

- none

### 3.3 AIR SUPPLY SYSTEM

#### Description

- Primary air: Bottom front of the heater
- Secondary air: sides of the heater Refer appendix 6 for drawing details

#### Characterization

The following table shows the inlet and outlet sections of each system. The air introduction system number is referred to on a set of drawings in Appendix 6.

AIR INTRODUCTION SYSTEM		INLET (1) sq. in.			OUTLET (sq. in.)
Identification	Type	Imin	Imax	Controlled	
A *	Primary	0.11	2.773	Yes	7.779
B *	Secondary	2.699	2.699	Fix	2.242
C *	Pilot	0.774	0.774	Fix	0.0769

\* This section would be filled by measuring and comparing with the manufacturer’s drawings included in the test report.

#### Legend

Identification: Tag name referred to on drawings in Appendix 14, section airflow pattern

Type: Characterization of air intake

Imin: Minimum air intake of a particular air channel

Imax: Maximum air intake of a particular air channel

Controlled: Determines if a provision for air control is present

Outlet: Total air outlet of a particular air channel

### 3.4 OPERATION DURING TEST

All runs have been found appropriate, no anomalies happened and all runs below have been validate and found compliant. All load logs have been positioned east-west direction into the firebox. No logs have been debarked, all logs were split to meet individual and total load weight range for the firebox. None of them have been squared. Negatives weight found on filters stick on gaskets and it were handled property, no negative weight on gaskets or probe.

#### Run #1.1

This run was performed on April 1<sup>st</sup> 2019. It lasted 127 minutes and a maximum burn rate was obtained at 3.72 kg/hr & emission at 3.4 gr/hr. The air inlet damper was at the maximum opening.

#### Run #1.2

This run was performed on April 1<sup>st</sup> 2019 as a continuation of the maximum burn rate (run1.1). It lasted 472 minutes and a Minimum burn rate was obtained at 1.03 kg/hr & emission at 0.70 gr/hr. The air inlet damper was at the minimum setting.

#### Run #21

This run was performed on April 3<sup>rd</sup> 2019. It lasted 327 minutes and a medium burn rate was obtained at 1.45 kg/hr & emission at 0.62 gr/hr. The air inlet damper was at the medium setting.

- Details: Refer to the front page of each test run data sheets found in appendix for the detailed test sequence showing air supply settings and adjustments, fuel bed adjustments and operational specifics of the test unit.

#### Test fuel

- Type of wood: Cord wood Red Oak, 18 to 28% dry basis moisture content
- Description: for each test, description of the fuel is found on the front page of each test run data sheet together with photograph in appendix.

### 3.5 START-UP OPERATION

The complete manufacturer's firing procedure of each burn rate category is fully described in appendix 13.

### 3.6 SAMPLING LOCATIONS

Particulate samples are collected from the dilution tunnel at a point 15 feet from the tunnel entrance. The tunnel has two elbows in the system ahead of the sampling section. The sampling section is a continuous 20-foot section of 8-inch diameter pipe straight over its entire length. Tunnel velocity pressure is determined by a standard pitot tube located 48 inches from the beginning of the sampling section. Thermocouple is installed on the pitot tube to measure the dry bulb temperature. MC is assumed, as allowed, to be 4%. Tunnel samplers are located 56 inches downstream of the pitot tube and 24 inches upstream from the end of this section.

### 3.7 DRAWINGS

Various drawings of the stack gas sampling train and of dilution tunnel system are found in Appendix 6.

### 3.8 EMISSIONS EFFICIENCY TESTING EQUIPMENT LIST

The complete test equipment list together with all corresponding calibration data can be found in Appendix 3.

## 4 SAMPLING METHODS

### 4.1 PARTICULATE SAMPLING

Particulates were sampled in strict accordance with ASTM E2515. This method uses two identical sampling systems with Gelman A/E 61631 binder free (or equivalent), 47 mm diameter EMFAB TX40H 120-WW Pall filters. The dryers used in the sample systems are filled with "Drierite" before each test run.

## 5 QUALITY ASSURANCE

### 5.1 INSTRUMENT CALIBRATION

#### 5.1.1 GAS METERS

At the conclusion of each test program the gas meters are verified using the reference dry gas meter. This process involves sampling the train operation for 1 cubic foot of volume. With readings made to .01 fr', the resolution is 1 %, giving an accuracy higher than the 2% required by the standard.

#### 5.1.2 SCALES

Before each test program, the different scales used are checked with traceable calibration weights to ensure their accuracy.

#### 5.1.3 GAS ANALYZERS

The continuous analyzers are zeroed and spanned before each test with NBS traceable gases. A mid-scale multi-component calibration gas is then analyzed (values are recorded). At the conclusion of a test, the instruments are checked again with zero, span and calibration gases (values are recorded only). The drift in each meter is then calculated and must not exceed 5% of the scale used for the test.

### 5.2 TEST METHOD PROCEDURES

#### 5.2.1 LEAK CHECK PROCEDURES

Before and after each test, each sample train is tested for leaks. Leakage rates are measured and must not exceed 0.02 CFM or 4% of the sampling rate. Leak checks are performed checking the entire sampling train. Pre-test and post-test leak checks are conducted with a vacuum of 5 inches of mercury. Vacuum is monitored during each test and the highest vacuum reached is then used for the post-test vacuum value. If leakage limits are not met, the test run is rejected. During these tests, the vacuum is typically less than 2 inches of mercury. Thus, leakage rates reported are expected to be much higher than actual leakage during the tests.

#### 5.2.2 TUNNEL VELOCITY FLOW MEASUREMENT

The tunnel velocity is calculated from a center point pitot tube signal multiplied by an adjustment factor. This factor is determined by a traverse of the tunnel as prescribed in EPA Method 1. Final tunnel velocities and flow rates are calculated from EPA Method 2, Equation 6.9 and 6.10. (Tunnel cross sectional area is the average from both lines of traverse.)

Pitot tubes are cleaned before each test and leak checks are conducted after each test.

#### 5.2.3 PM SAMPLING PROPORTIONALITY (ASTM E2515)

Proportionalities were calculated in accordance with ASTM E2515. The data and results are found in appendix.

## APPENDIX 1: Raw data, forms and results

## Paramètres

Tous les facteurs de corrections et autres paramètres qui peuvent être modifiés par l'utilisateur du fichier sont regroupés ici.

Code verrouillage: WOL

### Description du test

Test standard	EPA
Run #	1
Date	01-04-2019
Technicien	S.B.
Project #	PI-20190

### Description de l'unité

Manufacturier	WOLFSTEEL	
Modèle	EPI3	
Combustion system	Non-Cat	
Appliance type	INSERT	
Firebox volume	1,79	cu ft.
Appliance weight empty	n.a	lbs
Fan (no, Standard, Option)	OPT.	

### Paramètres du test

Logging time	1	min
Manufacturer's rated heat output	n.a	BTU/h Donnée fournie par le manufacturier
Targeted category	1	
Targeted output	n.a	BTU/h
Cp steel	n.a	BTU/lb-°F

### Échantillonnage

Blank sampling rate	0,20	cuft/min
Internal probe diameter	0,18	in.
Calibration Factor (DGM #1):	1,010	Dimensionless
Equipment number (DGM #1):	EM 178	
Calibration Factor (DGM #2):	0,987	Dimensionless
Equipment number (DGM #2):	EM 179	
Calibration Factor (DGM #3):	0,996	Dimensionless
Equipment number (DGM #3):	EM 070	Dimensionless

### Tunnel

Targeted tunnel flow rate	300	scfm
Tunnel diameter	8	in.
Molecular weight	29	29 ASTM E 2515
Pitot tube type	Standard	
Pitot tube coefficient	0,99	Dimensionless

Project nu.	PI-20190
Date	01-04-2019
Technicien	S.B.

### Fuel data

Fuel type	Cord
Fuel specie	Oak
HHV	20207,0 kJ/kg
%C	49,5
%H	6,6
%O	43,7
%Ash	0,2
HHV	8689,9 Btu/lb
LHV	7600,4 Btu/lb

Default Fuel Values		
	D. Fir	Oak/Maple
HHV	19 810	20 207
%C	48,73	49,5
%H	6,87	6,62
%O	43,9	43,7
%Ash	0,5	0,2
HHV (Btu/lb)	8519	8690
LHV (Btu/lb)	7451	7600



Adjunct to ASTM E XXXX Wood Heater Cordwood Test Method - May 10, 2017 Version  
 Cordwood Fuel Load Calculators - 10 lb/ft<sup>3</sup> Nominal Load Density  
 Core 45-65% of Total Load Weight, Remainder 35-55% of Total Load Weight  
 Values to be input manually

For All Usable Firebox Volumes - High Fire Test Only						
Nominal Required Load Density (wet basis)	10	lb/ft <sup>3</sup>				
Usable Firebox Volume	1,79	ft <sup>3</sup>				
Total Nom. Load Wt. Target	17,90	lb				
Total Load Wt. Allowable Range	17,00	to	18,80	lb		
Core Target Wt. Allowable Range	8,10	to	11,60	lb		
Remainder Load Wt. Allowable Range	6,30	to	9,80	lb		
					Mid-Point	
Core Load Pc. Wt. Allowable Range	2,70	to	4,50	lb	3,60	
Remainder Load Pc. Wt. Allowable Range	1,80	to	9,80	lb	5,80	
		Pc. #				
Core Load Piece Wt. Actual	1	3,75	lb	In Range		
	2	3,58	lb	In Range		
	3	3,40	lb	In Range		
Core Load Total. Wt. Actual		10,72	lb	In Range		
		Pc. #				
Remainder Load Piece Wt.	1	2,06	lb	In Range		
(1 to 3 Pcs.)	2	5,17	lb	In Range		
	3		lb	NA		
Remainder Load Tot. Wt. Act		7,23	lb	In Range		
Total Load Wt. Actual		17,95	lb	In Range		
Core % of Total Wt.		60%		In Range	45-65%	
Remainder % of Total Wt.		40%		In Range	35-55%	
Actual Load % of Nominal Target		100%		In Range	95-105%	
Actual Fuel Load Density		10,0	lb/ft <sup>3</sup>			
<b>Kindling and Start-up Fuel</b>						
Maximum Kindling Wt. (20% of Tot. Load Wt.)		3,59	lb			
Actual Kindling Wt.		3,50	lb	In Range	19,5%	
Maximum Start-up Fuel Wt. (30% of Tot. Load Wt.)		5,39	lb			
Actual Start-up Fuel Wt.		5,00	lb	In Range	27,8%	
Allowable Residual Start-up Fuel Wt. Range	1,8	to	3,6	lb	Mid-Point	
Actual Residual Start-up Fuel Wt.		2,7	lb	In Range	2,7	
Total Wt. All Fuel Added (wet basis)		26,45	lb			
<b>High Fire Test Run End Point Range</b>						
	Low		High		Mid-Point	
Based on Fuel Load Wt. (w/tares)	1,6	to	2,0	lb	1,8	
Actual Fuel Load Ending Wt.		1,6	lb	In Range		

Fuel Piece Moisture Reading (%-dry basis)							
	1	2	3	Ave.		Pc. Wt. Dry Basis	
	18,6	18,9	21,7	19,7	In Range	3,13	1,42
	19,6	25,3	23,4	22,8	In Range	2,91	1,32
	20,2	18,3	21,4	20,0	In Range	2,84	1,29
	22,2	18,9	19,8	20,3	In Range	1,72	0,78
	19,6	20,8	18,4	19,6	In Range	4,32	1,96
				NA	NA	NA	NA
Total Load Ave. MC (%-dry basis)				20,4	In Range		
Total Load Ave. MC % (wet basis)				16,9			
Total Test Load Weight (dry basis)						14,91	6,76
<b>Kindling Moisture (%-dry basis)</b>							
	9	9	9	9,0	In Range	3,21	1,46
<b>Start-up Fuel Moisture Readings (%-dry basis)</b>							
	20	20	20	20,0	In Range	4,17	1,89
Total Wt. All Fuel Added (dry basis)						22,29	10,11
Total Wt. All Fuel Burned (dry basis)						18,0	8,1

Load pieces Length in. 16 in.

Adjunct to ASTM E XXXX Wood Heater Cordwood Test Method - May 10, 2017 Version

Cordwood Fuel Load Calculators - 12 lb/ft<sup>3</sup> Nominal Load Density  
 Core 45-65% of Total Load Weight, Remainder 35-55% of Total Load Weight

Values to be input manually

THIS DOCUMENT IS NOT AN ASTM STANDARD; IT IS UNDER CONSIDERATION WITHIN AN ASTM TECHNICAL COMMITTEE BUT HAS NOT RECEIVED ALL APPROVALS REQUIRED TO BECOME AN ASTM STANDARD. IT SHALL NOT BE REPRODUCED OR CIRCULATED OR QUOTED, IN WHOLE OR IN PART, OUTSIDE OF ASTM COMMITTEE ACTIVITIES EXCEPT WITH THE APPROVAL OF THE CHAIRMAN OF THE COMMITTEE HAVING JURISDICTION AND THE PRESIDENT OF THE SOCIETY. COPYRIGHT ASTM, 100 BARR HARBOR DRIVE, WEST CONSHOHOCKEN, PA 19380. ALL RIGHTS RESERVED.

For Usable Firebox Volumes up to 3.0 ft <sup>3</sup> - Low and Medium Fire				
Nominal Required Load Density (wet basis)	12	lb/ft <sup>3</sup>		
Usable Firebox Volume	1.79	ft <sup>3</sup>		
Total Nom. Load Wt. Target	21.48	lb		
Total Load Wt. Allowable Range	20.41	to	22.55	lb
Core Target Wt. Allowable Range	9.666	to	13.96	lb
Remainder Load Wt. Allowable Range	7.52	to	11.81	lb
			Mid-Point	
Core Load Fuel Pc. Wt. Allowable Range	3.22	to	5.37	lb
Remainder Load Pc. Wt. Allowable Range	2.15	to	6.44	lb
			4.30	
	Pc. #			
Core Load Piece Wt. Actual	1	4.36	lb	In Range
	2	4.39	lb	In Range
	3	4.58	lb	In Range
Core Load Total. Wt. Actual		13.33	lb	In Range
	Pc. #			
Remainder Load Piece Wt.	1	2.77	lb	In Range
(2 or 3 Pcs.)	2	5.32	lb	In Range
	3		lb	NA
Remainder Load Piece Weight Ratio - Small/Large		52%		In Range ≤ 67%
Remainder Load Tot. Wt. Act		8.09	lb	In Range
Total Load Wt. Actual		21.42	lb	In Range
Core % of Total Wt.		62%		In Range 45-65%
Remainder % of Total Wt.		38%		In Range 35-55%
Actual Load % of Nominal Target		100%		In Range 95-105%
Actual Fuel Load Density		12.0	lb/ft <sup>3</sup>	
Allowable Charcoal Bed Wt. Range (lb)	2.2	to	4.2	lb
Actual Charcoal Bed Wt.		3.8	lb	In Range
Actual Fuel Load Ending Wt.		0.0	lb	Valid Test ≥ 90%
Total Wt. of Fuel Burned During Test Run lb.		21.4	lb	
Load pieces Length in.		16	in.	

Fuel Piece Moisture Reading (%-dry basis)									
1	2	3	Ave.			Pc. Wt. Dry Basis			
18.1	18.2	26.2	20.8	In Range	3.61	lb	1.64	kg	
19.3	26.2	18.3	21.3	In Range	3.62	lb	1.64	kg	
18.3	18.9	18.4	18.5	In Range	3.86	lb	1.75	kg	
20.2	22.3	18.6	20.4	In Range	2.30	lb	1.04	kg	
25.2	18.8	19.7	21.2	In Range	4.39	lb	1.99	kg	
			NA	NA	NA	lb	NA	kg	
Total Load Ave. MC % (dry basis)				20.5	In Range				
Total Load Ave. MC % (wet basis)				17.0					
Total Test Load Weight (dry basis)						17.78	lb	8.07	kg
Total Fuel Weight Burned During Test Run (dry basis)						17.8	lb	8.07	kg

For Usable Firebox Volumes above 3.0 ft <sup>3</sup> - Low and Medium Fire				
Nominal Required Load Density (wet basis)	12	lb/ft <sup>3</sup>		
Usable Firebox Volume		ft <sup>3</sup>		
Total Nom. Load Wt. Target	0	lb		
Total Load Wt. Allowable Range	0.00	to	0.00	lb
Core Target Wt. Allowable Range	0.00	to	0.00	lb
Remainder Load Wt. Allowable Range	0.00	to	0.00	lb
			Mid-Point	
Core Load Fuel Pc. Wt. Allowable Range	0.00	to	0.00	lb
Remainder Load Pc. Wt. Allowable Range	0.00	to	0.00	lb
	Pc. #			
Core Load Piece Wt. Actual	1		lb	In Range
	2		lb	In Range
	3		lb	In Range
Core Load Total. Wt. Actual		0.00	lb	In Range
	Pc. #			
Remainder Load Piece Wt.	1		lb	In Range
(3 or 4 Pcs.)	2		lb	In Range
	3		lb	In Range
	4		lb	NA
Remainder Load Piece Weight Ratio - Small/Large		#NOMBRE!		≤ 67%
Remainder Load Tot. Wt. Act		0.00	lb	In Range
Total Load Wt. Actual		0.00	lb	In Range
Core % of Total Wt.		#DIV/0!		#DIV/0! 45-65%
Remainder % of Total Wt.		#DIV/0!		#DIV/0! 35-55%
Actual Load % of Nominal Target		#DIV/0!		#DIV/0! 95-105%
Actual Fuel Load Density		#DIV/0!	lb/ft <sup>3</sup>	
Allowable Charcoal Bed Wt. Range (lb)	0.1	to	-0.1	lb
Actual Charcoal Bed Wt.			lb	Out of Range 0.0
Actual Fuel Load Ending Wt.			lb	Valid Test ≥ 90%
Total Wt. of Fuel Burned During Test Run lb.		0.0	lb	

Fuel Piece Moisture Reading (%-dry basis)									
1	2	3	Ave.			Pc. Wt. Dry Basis			
			#DIV/0!	#DIV/0!	#DIV/0!	lb	#DIV/0!	kg	
			#DIV/0!	#DIV/0!	#DIV/0!	lb	#DIV/0!	kg	
			#DIV/0!	#DIV/0!	#DIV/0!	lb	#DIV/0!	kg	
			NA	NA	NA	lb	NA	kg	
Total Load Ave. MC % (dry basis)				#DIV/0!	#DIV/0!				
Total Load Ave. MC % (wet basis)				#DIV/0!					
Total Test Load Weight (dry basis)						#DIV/0!	lb	#DIV/0!	kg
Total Fuel Weight Burned During Test Run (dry basis)						#DIV/0!	lb	#DIV/0!	kg

	Start	End
Barometer (kPa):	101,8	102,1
Barometer (in.Hg):	30,061529	30,15011865
Dry Bulb (F):	70,16	68,5
Humidity (%):	20,6	22,6
Air velocity (ft/min)	0	0

High fire test				
DGM #1	Final:	31195,524 cuft	Final:	883358,850 Liter
	Initial:	31170,076 cuft	Initial:	882638,250 Liter
DGM #2	Final:	29424,910 cuft	Final:	833220,650 Liter
	Initial:	29399,943 cuft	Initial:	832513,660 Liter
DGM room			Final:	826,480 cuft
			Initial:	704,700 cuft

min or med burnrate				
DGM #1	Final:	31291,115 cuft	Final:	886065,690 Liter
	Initial:	31195,616 cuft	Initial:	883361,440 Liter
DGM #2	Final:	29518,322 cuft	Final:	835865,790 Liter
	Initial:	29425,005 cuft	Initial:	833223,330 Liter
DGM room			Final:	944,900 cuft
			Initial:	826,480 cuft

Numéro de la ligne dans "Raw data" à partir duquel les données du test commence	42
Numéro de la ligne dans "Raw data" à partir duquel les données du highfire test commence	72
Numéro de la ligne dans "Raw data" à partir duquel les données du min ou medium fire test commence	182

Autres données à rentrer: dans preload data, load data, traverse et filter set weight

<b>Project nu.</b>	PI-20190
<b>Date</b>	01-04-2019
<b>Technicien</b>	S.B.

### Tunnel Traverse Worksheet (for velocity calculations)

Static Pressure:  in. H2O  
 Barometer: 30,062 in. Hg

**Pour un tunnel de 12" et plus, prendre 6 lectures**

	TUNNEL VELOCITY	TUNNEL TEMP	SQUARE ROOT
	In. wc	°F	
A center			0,0000
B center			0,0000
A1			0,0000
A2			0,0000
A3			0,0000
A4			0,0000
A5			0,0000
A6			0,0000
B1			0,0000
B2			0,0000
B3			0,0000
B4			0,0000
B5			0,0000
B6			0,0000
AVERAGE	#DIV/0!	#DIV/0!	0,0000

PITOT CONSTANT=  
0,989

**Pour un tunnel moins de 12", prendre 4 lectures**

	TUNNEL VELOCITY	TUNNEL TEMP	SQUARE ROOT
	In. wc	°F	
A center	0,058	76,84	0,2408
B center	0,057	75,63	0,2387
A1	0,058	76,71	0,2408
A2	0,064	76,55	0,2530
A3	0,069	76,17	0,2627
A4	0,063	75,96	0,2510
B1	0,050	75,090	0,2236
B2	0,048	74,970	0,2191
B3	0,048	74,580	0,2191
B4	0,050	74,030	0,2236
AVERAGE	0,0565	75,6530	0,2372

<b>Project nu.</b>	PI-20190
<b>Date</b>	01-04-2019
<b>Technicien</b>	S.B.

**Filter set weight highfire**

	System 1 (g) 1st hour				System 1 (g)				System 2 (g)				Ambient blank (g)	Date	Heure
	probe	front	back	gasket	probe	front	back	gasket	probe	front	back	gasket	Filter		
Number	20	5	6	18	21	7	8	28	40	9	10	29	11		
Before (1)															
Before (2)															
Before (3)															
Before (4)															
Before (5)	108,8426	0,0824	0,0878	34,1360	108,7396	0,0899	0,0893	35,3686	110,1100	0,0855	0,0859	34,3245	0,0863	2019-03-29	10H00
Before (6)	108,8426	0,0824	0,0878	34,1360	108,7396	0,0899	0,0893	35,3686	110,1100	0,0855	0,0859	34,3245	0,0863	2019-04-01	7H00
After (1)	108,8427	0,0851	0,0878	34,1383	108,7397	0,0904	0,0893	35,3707	110,1102	0,0886	0,0860	34,3266	0,0863	2019-04-01	15H00
After (2)	108,8427	0,0850	0,0878	34,1371	108,7396	0,0903	0,0890	35,3705	110,1102	0,0886	0,0860	34,3258	0,0863	2019-04-10	11h00
After (3)	108,8427	0,0850	0,0878	34,1372	108,7396	0,0903	0,0890	35,3690	110,1102	0,0886	0,0860	34,3257	0,0863	2019-04-15	8H00
After (4)															
After (5)															
After (6)	108,8427	0,0850	0,0878	34,1372	108,7396	0,0903	0,0890	35,3690	110,1102	0,0886	0,0860	34,3257	0,0863	2019-04-15	8H00
Difference	0,0001	0,0026	0,0000	0,0012	0,0000	0,0004	-0,0003	0,0004	0,0002	0,0031	0,0001	0,0012	0,0000		
Total (mg)		3,9				4,4				4,6				0	
Total ajusté (mg)		<b>3,90</b>				<b>4,40</b>				<b>4,60</b>					

<b>Project nu.</b>	PI-20190
<b>Date</b>	01-04-2019
<b>Technicien</b>	S.B.

**Filter set weight Low/ medium fire**

	System 1 (g) 1st hour				System 1 (g)				System 2 (g)				Ambient blank (g)	Date	Heure
	probe	front	back	gasket	probe	front	back	gasket	probe	front	back	gasket	Filter		
Number	30	12	13	9	32	14	15	42	42	16	17	45	19		
Before (1)															
Before (2)															
Before (3)															
Before (4)															
Before (5)	110,2223	0,0880	0,0867	34,9900	110,1775	0,0886	0,0829	35,5181	110,3104	0,0856	0,0898	34,2475	0,0865	2019-03-29	10H00
Before (6)	110,2223	0,0880	0,0867	34,9900	110,1775	0,0886	0,0829	35,5181	110,3104	0,0856	0,0898	34,2475	0,0865	2019-04-01	7H00
After (1)	110,224	0,0887	0,0848	34,9923	110,1775	0,0892	0,081	35,5213	110,3104	0,0868	0,0904	34,2494	0,0867	2019-04-02	8H00
After (2)	110,2240	0,0885	0,0848	34,9920	110,1775	0,0892	0,0810	35,5208	110,3105	0,0868	0,0902	34,2490	0,0867	2019-04-10	15h00
After (3)	110,2240	0,0885	0,0848	34,9920	110,1775	0,0892	0,0810	35,5208	110,3105	0,0868	0,0902	34,2490	0,0867	2019-04-15	8H00
After (4)															
After (5)															
After (6)	110,2240	0,0885	0,0848	34,9920	110,1775	0,0892	0,0810	35,5208	110,3105	0,0868	0,0902	34,2490	0,0867	2019-04-15	8H00
Difference	0,0017	0,0005	-0,0019	0,0020	0,0000	0,0006	-0,0019	0,0027	0,0001	0,0012	0,0004	0,0015	0,0002		
Total (mg)		2,3				3,7				3,2			0,2		
Total ajusté (mg)		<b>2,10</b>				<b>3,50</b>				<b>3,00</b>					

<b>Project nu.</b>	PI-20190
<b>Date</b>	01-04-2019
<b>Technicien</b>	S.B.

SFBA EPA EMISSION RESULTS

RESULTS

**Average emission rate:** 3,4 g/hr

Burn Rate : 3,724 Dry kg/hr

**Test Duration:** 127 min

PRESSURE FACTOR: DGM 1 0,97845  
 DGM 2 0,97617  
 DGM 3 1,00621

BAROMETRIC PRESSURE  
 Average: 30,10582367 in Hg  
 Start: 30,06152868 in Hg  
 End: 30,15011865 in Hg

TEMPERATURE FACTORS DGM 1 0,98428  
 DGM 2 0,98387  
 DGM 3 0,99532

DGM CONTROLLER VALUES

DGM 1 Final: 31195,524 Cuft  
 Initial: 31170,076 Cuft

VOLUMES SAMPLED DGM 1 24,755 SCft  
 DGM 2 23,674 SCft  
 DGM 3 121,447 SCft

DGM 2 Final: 29424,910 Cuft  
 Initial: 29399,943 Cuft

DGM #3 Final: 826,480 Cuft  
 Initial: 704,700 Cuft

TOTAL TUNNEL VOLUME : 38687

TEMPERATURES

SAMPLE RATIOS  
 Sample Train 1: 1562,826  
 Sample Train 2: 1634,145

DGM 1 536,433 °R  
 DGM 2 536,658 °R

Paticulate concentration  
 Sample Train 1 **0,000178** g/dscf  
 Sample Train 2 **0,000194** g/dscf  
 Room **0,000000** g/dscf

CALIBRATION FACTORS

DGM 1 1,0101  
 DGM 2 0,9873  
 DGM #3 0,9958

TUNNEL FLOW RATE: 304,626 Dscfm

TOTAL EMISSIONS  
 Sample Train 1 **6,88** g  
 Sample Train 2 **7,52** g

PARTICULATE CATCH  
 Total Sample Train 1: 4,40 mg  
 Total Sample Train 2: 4,60 mg  
 Total Sample Train 1 1st hour: 3,90 mg

EMISSION RATES  
 Sample Train 1 **3,25** g/hr  
 Sample Train 2 **3,55** g/hr

1st hour emission rate **6,10** g/hr

DEVIATION: 4,45%

Cs Train 1 Train 2  
 0,0001777 0,0001943

* Elapsed Time min	* Raw data row	* Weight				*1 Flue		*2 Room		*3 Tunnel		*4 Unit		*5 Unit		*6 Unit		*7 Unit		*8 Unit		Mass flow 1	DGM 1	DGM 1	Filter 1	Mass flow 2	DGM 2	DGM 2	Filter 2
		Remaining	CO	CO <sub>2</sub>		Gas	Temp	Dry Bulb	Top	Back	R.Side	L.Side	Bottom	Reading	Inlet T	Outlet T	Temp	Reading	Inlet T	Outlet T	Temp	cuft/min	oF	oF	oF	cuft/min	oF	oF	oF
		lbs	%	%	%	°F	°F	°F	°F	°F	°F	°F	°F	°F	°F	°F	°F	°F	°F	°F	°F	°F	°F	°F	°F	°F	°F	°F	°F
0,00	42,00	8,5	0,0	0,0	69,4	68,6	73,4	69,0	67,8	68,2	68,1	69,4	0,18	71,81	71,74	85,79	0,16	72,15	71,89	83,31	83,31								
1,0	43,0	8,4	0,0	0,1	117,8	68,6	77,6	76,7	67,8	68,2	68,1	69,6	0,19	72,05	71,86	85,07	0,19	72,44	71,96	82,24	82,24								
2,0	44,0	8,3	0,0	5,4	216,4	68,5	78,4	76,7	67,8	68,3	68,2	69,6	0,19	72,13	71,89	84,42	0,19	72,55	71,97	81,64	81,64								
3,0	45,0	8,1	0,1	5,4	345,9	68,7	84,4	162,4	67,9	68,8	68,3	69,6	0,19	72,11	71,93	83,72	0,19	72,60	71,98	81,15	81,15								
4,0	46,0	7,9	0,1	7,7	528,3	68,7	95,7	265,8	68,0	69,9	69,0	69,7	0,19	72,07	71,95	83,09	0,19	72,65	71,97	80,77	80,77								
5,0	47,0	7,6	0,5	11,2	615,4	68,8	103,5	356,2	68,1	72,1	70,8	69,8	0,19	72,15	72,01	84,92	0,19	72,71	72,00	83,37	83,37								
6,0	48,0	7,4	0,6	12,2	660,6	68,8	110,1	441,4	68,5	75,8	73,9	70,0	0,19	72,33	72,07	84,79	0,19	72,82	72,02	84,83	84,83								
7,0	49,0	7,1	0,5	12,6	759,5	68,9	119,1	525,7	69,1	81,1	78,1	70,3	0,19	72,46	72,12	84,17	0,19	72,93	72,07	86,60	86,60								
8,0	50,0	6,8	0,4	15,0	785,6	68,9	124,1	599,1	70,1	88,5	83,5	70,6	0,19	72,60	72,17	83,59	0,19	73,04	72,11	86,91	86,91								
9,0	51,0	6,5	0,5	14,6	735,6	68,8	125,3	666,0	71,6	97,5	89,8	70,9	0,19	72,76	72,26	83,17	0,19	73,20	72,19	86,64	86,64								
10,0	52,0	6,3	0,6	12,5	668,3	68,8	121,4	793,2	73,1	107,1	96,1	71,2	0,19	72,96	72,36	82,81	0,19	73,40	72,30	86,18	86,18								
11,0	53,0	6,1	0,3	10,0	634,7	69,0	118,7	802,5	74,1	115,0	102,6	71,3	0,19	73,08	72,42	82,43	0,19	73,52	72,37	85,72	85,72								
12,0	54,0	5,9	0,2	8,9	643,5	69,1	118,6	808,2	76,1	121,4	109,0	71,4	0,19	73,21	72,45	82,11	0,19	73,60	72,48	85,30	85,30								
13,0	55,0	5,7	0,3	9,8	649,3	68,8	119,9	813,2	78,7	128,7	114,5	71,6	0,19	73,24	72,50	81,83	0,19	73,65	72,54	84,94	84,94								
14,0	56,0	5,5	0,3	10,1	666,3	68,6	121,3	824,3	80,2	135,9	119,3	71,8	0,19	73,33	72,55	81,55	0,19	73,76	72,61	84,58	84,58								
15,0	57,0	5,2	0,4	10,8	673,3	69,0	121,9	841,6	87,8	142,9	123,4	72,0	0,19	73,47	72,64	81,32	0,19	73,89	72,71	84,31	84,31								
16,0	58,0	5,0	0,4	10,7	679,8	69,1	122,6	858,7	97,1	146,6	127,7	72,3	0,19	73,50	72,66	81,12	0,19	73,90	72,76	84,04	84,04								
17,0	59,0	4,8	0,3	11,0	675,3	68,4	123,0	868,0	101,5	150,0	131,9	72,3	0,19	73,63	72,76	80,94	0,19	74,02	72,83	83,80	83,80								
18,0	60,0	4,6	0,2	10,9	673,7	68,4	123,4	870,2	98,5	153,8	135,9	72,4	0,19	73,72	72,82	80,87	0,19	74,12	72,92	83,60	83,60								
19,0	61,0	4,3	0,2	11,0	668,8	68,6	123,0	869,5	110,6	158,8	140,3	72,5	0,19	73,84	72,89	80,77	0,19	74,23	73,01	83,41	83,41								
20,0	62,0	4,2	0,2	10,6	657,2	68,8	121,6	865,3	106,1	164,7	145,0	75,0	0,19	73,92	72,94	80,68	0,19	74,34	73,12	83,28	83,28								
21,0	63,0	4,0	0,2	10,2	652,0	69,0	121,0	860,5	126,1	170,9	150,0	78,4	0,19	74,02	72,98	84,67	0,19	74,38	73,17	83,11	83,11								
22,0	64,0	3,8	0,1	10,1	652,6	69,0	120,8	859,8	115,2	177,1	155,2	72,7	0,19	74,08	73,05	84,76	0,19	74,44	73,23	82,99	82,99								
23,0	65,0	3,7	0,1	10,2	648,6	68,8	120,1	857,7	119,5	183,4	160,6	81,2	0,19	74,13	73,08	84,51	0,19	74,53	73,31	82,87	82,87								
24,0	66,0	3,5	0,1	9,9	642,8	69,0	119,9	853,9	127,0	189,8	166,2	79,1	0,19	74,23	73,16	84,27	0,19	74,67	73,38	82,78	82,78								
25,0	67,0	3,3	0,1	9,6	635,5	69,1	119,0	851,8	154,2	196,4	171,8	85,0	0,19	74,23	73,21	84,03	0,19	74,70	73,45	82,71	82,71								
26,0	68,0	3,2	0,1	9,4	633,0	69,3	118,8	851,2	146,5	203,1	177,2	86,4	0,19	74,22	73,26	83,77	0,19	74,72	73,50	82,59	82,59								
27,0	69,0	3,0	0,1	9,4	630,9	69,2	117,5	848,7	134,8	209,9	183,0	78,9	0,19	74,21	73,30	83,53	0,19	74,76	73,57	82,51	82,51								
28,0	70,0	2,9	0,1	9,4	630,9	69,1	117,7	848,0	168,3	216,8	189,0	73,5	0,19	74,21	73,31	83,29	0,19	74,73	73,63	82,43	82,43								
29,0	71,0	2,7	0,1	9,4	627,4	69,2	117,4	850,6	156,5	223,7	194,9	93,6	0,19	74,19	73,32	83,11	0,19	74,70	73,66	82,35	82,35								
30,0	72,0	2,0,4	0,1	9,2	566,1	69,1	133,9	817,5	181,3	230,9	201,7	89,8	0,19	74,34	73,36	82,98	0,19	74,77	73,68	82,51	82,51								
31,0	73,0	2,0,2	0,2	6,2	582,8	69,3	119,7	802,7	203,2	237,9	207,8	90,4	0,19	74,50	73,43	82,73	0,19	74,88	73,76	82,45	82,45								
32,0	74,0	2,0,1	0,1	7,5	606,0	69,3	118,4	816,3	202,4	244,9	213,8	74,2	0,19	74,61	73,48	82,55	0,19	75,00	73,80	82,32	82,32								
33,0	75,0	1,9,9	0,2	8,6	603,2	69,7	117,7	831,7	218,2	251,1	219,3	74,1	0,19	74,68	73,53	82,41	0,19	75,10	73,86	82,31	82,31								
34,0	76,0	1,9,7	0,2	8,2	598,8	69,4	116,4	836,7	235,3	257,2	224,5	81,7	0,19	74,62	73,54	82,31	0,19	75,09	73,92	82,23	82,23								
35,0	77,0	1,9,5	0,2	7,9	602,2	69,8	117,2	842,1	230,8	264,9	231,8	74,8	0,19	74,68	73,59	82,22	0,19	75,17	73,97	82,20	82,20								
36,0	78,0	1,9,3	0,2	8,1	638,0	69,8	121,4	852,6	227,1	272,4	192,8	115,3	0,19	75,05	73,68	82,24	0,19	75,39	74,04	82,24	82,24								
37,0	79,0	1,9,1	0,1	10,6	655,4	69,9	123,5	865,7	236,2	276,2	124,9	118,5	0,19	75,53	73,84	82,22	0,19	75,66	74,14	82,27	82,27								
38,0	80,0	1,8,9	0,1	11,1	661,2	70,1	126,0	879,9	247,1	280,6	234,3	121,2	0,19	76,08	73,98	82,27	0,19	76,01	74,25	82,34	82,34								
39,0	81,0	1,8,6	0,1	11,1	669,2	70,0	128,3	892,9	253,0	284,6	136,1	123,7	0,19	76,64	74,16	82,33	0,19	76,37	74,41	82,44	82,44								
40,0	82,0	1,8,4	0,1	11,4	685,5	70,2	130,0	906,9	247,6	290,1	250,9	126,3	0,19	77,17	74,33	82,36	0,19	76,73	74,56	82,55	82,55								
41,0	83,0	1,8,1	0,1	12,3	695,3	70,6	131,9	916,8	218,3	296,1	124,2	129,7	0,19	77,68	74,54	82,42	0,19	77,13	74,75	82,68	82,68								
42,0	84,0	1,7,9	0,1	12,5	694,3	70,7	132,9	924,4	206,7	301,7	264,4	132,4	0,19	78,16	74,78	82,51	0,19	77,53	74,95	82,80	82,80								
43,0	85,0	1,7,7	0,1	12,1	686,4	71,1	133,4	926,0	190,6	307,1	271,3	134,7	0,19	78,57	75,01	82,58	0,19	77,92	75,14	82,95	82,95								
44,0	86,0	1,7,4	0,1	11,4	685,2	71,4	133,4	925,8	189,7	312,1	277,6	136,8	0,19	78,94	75,23	82,71	0,19	78,27	75,37	83,14	83,14								
45,0	87,0	1,7,2	0,1	11,4	690,8	71,3	132,6	925,9	184,8	316,9	283,9	138,7	0,19	79,22	75,45	82,86	0,19	78,55	75,53	83,27	83,27								
46,0	88,0	1,6,9	0,1	11,8	691,6	71,8	132,1	927,9	179,0	321,3	290,5	140,6	0,19	79,37	75,58	82,99	0,19	78,73	75,70	83,46	83,46								
47,0	89,0	1,6,7	0,1	11,8	687,7	71,0	131,6	928,8	180,2	325,5	297,0	142,3	0,19	79,37	75,73	83,11	0,19	78,85	75,83	83,64	83,64								
48,0	90,0	1,6,5	0,1	11,6	686,0	70,7	130,8	928,0	177,9	329,4	303,5	143,8	0,19	79,20	75,82	83,26	0,19	78,83	75,93	83,77	83,77								
49,0	91,0	1,6,3	0,1	11,4	686,2	71,4	130,0	927,7	182,0	333,0	310,0	145,4	0,19	79,12	75,93	83,36	0,19	78,89	76,02	83,92	83,92								
50,0	92,0	1,6,1	0,1	11,4	684,5	71,3	129,6	928,2	178,4	336,6	316,4	146,8	0,19	78,89	75,99	83,49	0,19	78,83	76,10	84,07	84,07								
51,0	93,0	1,5,9	0,1	11,3	682,0	71,1	129,8	927,8	177,3	340,1	322,8	148,1	0,19	78,83	76,06	83,59	0,19	78,82	76,18	84,20	84,20								
52,0	94,0	1,5,6	0,1	11,2	681,2	71,3	128,9	928,2	173,9	343,7	329,2	149,5	0,19	78,84	76,13	83,71	0,19	78,88	76,28	84,32	84,32								
53,0	95,0	1,5,4	0,1	11,1	681,3	69,6	127,6	929,3	180,2	347,1	335,4	150,8	0,19	78,84	76,21	83,79	0,19	78,89	76,34	84,41	84,41								
54,0	96,0	1,5,3	0,1																										



82,0	124,0	9,9	0,2	10,0	649,9	71,5	121,6	905,8	175,8	436,1	469,2	186,8	0,19	78,50	77,06	84,73	0,19	78,64	77,31	84,62
83,0	125,0	9,7	0,2	9,9	647,0	71,6	121,9	906,3	176,7	438,4	472,5	188,2	0,19	78,61	77,11	84,70	0,19	78,73	77,36	84,64
84,0	126,0	9,6	0,2	9,9	645,8	71,2	120,7	906,1	177,2	440,8	475,5	189,6	0,19	78,76	77,17	84,61	0,19	78,87	77,40	84,66
85,0	127,0	9,4	0,2	9,8	644,5	71,6	121,6	906,1	176,1	443,1	478,7	190,9	0,19	78,83	77,21	84,53	0,19	78,95	77,46	84,65
86,0	128,0	9,2	0,2	9,8	641,8	71,4	120,9	904,7	177,3	445,2	481,7	192,3	0,19	78,93	77,26	84,48	0,19	79,04	77,52	84,67
87,0	129,0	9,1	0,2	9,7	640,5	71,4	120,2	903,8	177,8	447,5	484,7	193,6	0,19	79,09	77,37	84,44	0,19	79,18	77,58	84,67
88,0	130,0	8,9	0,2	9,7	639,7	71,9	120,7	903,2	178,8	449,5	487,7	195,0	0,19	79,13	77,39	84,38	0,19	79,19	77,61	84,66
89,0	131,0	8,8	0,2	9,7	638,0	72,2	119,8	902,1	184,7	451,6	490,6	196,3	0,19	79,02	77,42	84,30	0,19	79,16	77,66	84,69
90,0	132,0	8,6	0,2	9,6	637,6	71,9	120,4	900,8	188,4	453,6	493,6	197,7	0,19	78,99	77,46	84,25	0,19	79,19	77,70	84,67
91,0	133,0	8,4	0,2	9,6	635,2	71,3	120,3	899,7	189,9	455,9	496,4	199,1	0,19	79,08	77,50	84,21	0,19	79,25	77,77	84,66
92,0	134,0	8,3	0,2	9,6	635,5	71,4	120,4	897,9	192,0	457,9	499,2	200,4	0,19	79,22	77,57	84,23	0,19	79,30	77,83	84,68
93,0	135,0	8,2	0,2	9,6	634,4	71,3	120,3	896,4	191,1	460,0	502,0	201,8	0,19	79,25	77,62	84,22	0,19	79,36	77,86	84,68
94,0	136,0	8,0	0,2	9,6	634,2	71,9	119,8	894,5	194,5	461,8	504,7	203,3	0,19	79,17	77,65	84,19	0,19	79,34	77,90	84,68
95,0	137,0	7,9	0,2	9,6	634,8	71,7	120,5	893,8	264,8	463,8	507,3	204,7	0,19	79,14	77,69	84,13	0,19	79,31	77,92	84,65
96,0	138,0	7,7	0,2	9,7	635,3	72,2	119,3	892,7	222,8	465,7	509,9	206,1	0,19	79,14	77,75	84,11	0,19	79,32	77,97	84,67
97,0	139,0	7,6	0,2	9,6	634,7	71,7	120,0	892,0	270,4	467,7	512,3	207,6	0,19	79,14	77,77	84,11	0,19	79,32	77,97	84,69
98,0	140,0	7,4	0,2	9,6	633,6	71,9	119,3	889,6	271,9	469,7	514,8	209,2	0,19	79,10	77,81	84,04	0,19	79,30	78,00	84,64
99,0	141,0	7,3	0,2	9,5	632,8	71,5	119,8	887,5	273,4	471,7	517,1	210,6	0,19	78,91	77,82	83,99	0,19	79,23	78,05	84,66
100,0	142,0	7,1	0,2	9,5	631,7	72,0	119,5	886,0	275,1	473,7	519,5	212,1	0,19	78,86	77,88	84,00	0,19	79,22	78,09	84,65
101,0	143,0	7,0	0,2	9,5	631,7	71,8	119,4	885,3	276,6	475,5	521,8	213,6	0,19	78,83	77,91	83,97	0,19	79,19	78,12	84,65
102,0	144,0	6,9	0,2	9,4	631,3	71,4	119,0	885,1	278,2	477,7	523,8	215,2	0,19	78,79	77,91	83,95	0,19	79,12	78,12	84,65
103,0	145,0	6,7	0,2	9,4	632,8	71,9	119,7	885,7	279,8	479,7	525,9	216,8	0,19	78,63	77,90	83,93	0,19	78,99	78,16	84,67
104,0	146,0	6,6	0,2	9,5	632,7	71,4	119,0	886,5	281,7	481,9	527,8	218,4	0,19	78,57	77,92	83,92	0,19	79,00	78,16	84,65
105,0	147,0	6,4	0,2	9,4	633,7	71,4	119,7	888,2	283,3	484,1	529,6	220,1	0,19	78,52	77,90	83,89	0,19	79,02	78,19	84,65
106,0	148,0	6,3	0,2	9,4	634,2	71,6	119,2	894,4	285,2	486,2	531,4	221,7	0,19	78,65	77,94	83,83	0,19	79,12	78,22	84,65
107,0	149,0	6,2	0,2	9,5	631,8	72,2	119,0	903,5	287,0	488,1	533,1	223,4	0,19	78,73	77,96	83,81	0,19	79,16	78,26	84,66
108,0	150,0	6,1	0,2	9,2	626,0	71,6	118,3	908,9	288,3	490,6	534,7	225,0	0,19	78,81	77,99	83,79	0,19	79,21	78,28	84,61
109,0	151,0	5,9	0,2	8,9	615,9	71,5	118,1	907,5	290,2	492,8	536,3	226,6	0,19	78,73	78,00	83,80	0,19	79,20	78,31	84,64
110,0	152,0	5,9	0,1	8,7	609,5	71,3	117,6	900,8	292,2	495,0	537,8	228,1	0,19	78,76	78,01	83,75	0,19	79,28	78,35	84,61
111,0	153,0	5,8	0,1	8,5	606,1	71,8	117,1	895,7	293,9	497,2	539,1	230,0	0,19	78,83	78,04	83,72	0,19	79,35	78,40	84,60
112,0	154,0	5,6	0,1	8,6	601,7	71,8	115,8	891,1	296,0	499,3	540,3	231,7	0,19	78,71	78,04	83,65	0,19	79,26	78,42	84,61
113,0	155,0	5,5	0,1	8,5	598,9	71,7	116,3	885,9	298,0	501,6	541,4	233,5	0,19	78,64	78,03	83,63	0,19	79,23	78,41	84,57
114,0	156,0	5,4	0,1	8,5	595,6	72,1	115,5	880,4	299,9	503,6	542,5	235,2	0,19	78,73	78,06	83,59	0,19	79,30	78,43	84,55
115,0	157,0	5,3	0,1	8,4	592,2	71,5	115,9	873,6	301,7	505,8	543,6	237,0	0,19	78,79	78,11	83,55	0,19	79,37	78,47	84,55
116,0	158,0	5,2	0,1	8,3	589,2	71,8	115,6	867,0	303,6	508,0	544,6	238,9	0,19	78,88	78,14	83,51	0,19	79,43	78,49	84,51
117,0	159,0	5,2	0,1	8,2	586,3	72,1	115,1	860,4	305,7	509,9	545,4	240,4	0,19	79,02	78,17	83,46	0,19	79,49	78,54	84,50
118,0	160,0	5,0	0,1	8,1	582,6	72,0	114,9	853,6	307,6	512,3	546,2	242,5	0,19	78,97	78,19	83,42	0,19	79,41	78,55	84,45
119,0	161,0	4,9	0,1	8,0	579,7	71,5	113,7	846,5	309,8	514,3	546,9	244,3	0,19	78,98	78,18	83,37	0,19	79,43	78,58	84,42
120,0	162,0	4,9	0,1	7,9	576,3	71,4	113,5	839,0	312,1	516,4	547,6	246,0	0,19	78,86	78,18	83,30	0,19	79,37	78,60	84,38
121,0	163,0	4,8	0,1	7,8	572,6	71,8	113,4	831,5	314,2	518,4	548,3	247,9	0,19	78,82	78,20	83,29	0,19	79,37	78,62	84,34
122,0	164,0	4,7	0,1	7,7	568,6	71,6	113,1	822,9	316,4	520,3	548,9	249,6	0,19	78,73	78,19	83,26	0,19	79,35	78,64	84,29
123,0	165,0	4,6	0,1	7,4	561,5	71,9	112,4	812,0	318,8	522,0	549,4	251,4	0,19	78,61	78,16	83,21	0,19	79,21	78,60	84,25
124,0	166,0	4,6	0,1	6,9	552,8	71,4	112,0	799,9	321,2	523,8	550,0	253,4	0,19	78,56	78,15	83,14	0,19	79,20	78,61	84,16
125,0	167,0	4,5	0,1	6,7	548,4	71,7	111,3	788,6	323,7	525,2	550,4	255,0	0,19	78,61	78,17	83,09	0,19	79,23	78,61	84,15
126,0	168,0	4,5	0,1	6,6	543,7	72,1	110,1	778,3	326,0	526,8	550,9	256,9	0,19	78,71	78,19	82,99	0,19	79,27	78,65	84,08
127,0	169,0	4,4	0,1	6,5	539,6	71,8	109,9	769,0	328,6	528,1	551,2	258,6	0,19	78,85	78,24	82,89	0,19	79,37	78,66	84,01

SFBA EPA EMISSION RESULTS

RESULTS

**Average emission rate:** 0,70 g/hr

**Test Duration:** 472 min

Burn Rate : 1,025 Dry kg/hr

PRESSURE FACTOR: DGM 1 0,97845  
 DGM 2 0,97617  
 DGM 3 1,00621

BAROMETRIC PRESSURE  
 Average: 30,10582367 in Hg  
 Start: 30,06152868 in Hg  
 End: 30,15011865 in Hg

TEMPERATURE FACTORS DGM 1 0,97186  
 DGM 2 0,97066  
 DGM 3 0,98573

DGM CONTROLLER VALUES

DGM 1 Final: 31291,115 Cuft  
 Initial: 31195,616 Cuft

VOLUMES SAMPLED DGM 1 91,728 SCft  
 DGM 2 87,298 SCft  
 DGM 3 116,958 SCft

DGM 2 Final: 29518,322 Cuft  
 Initial: 29425,005 Cuft

DGM #3 Final: 944,900 Cuft  
 Initial: 826,480 Cuft

TOTAL TUNNEL VOLUME : 150151

TEMPERATURES

DGM 1 543,286 °R  
 DGM 2 543,961 °R

SAMPLE RATIOS  
 Sample Train 1: 1636,923  
 Sample Train 2: 1719,979

CALIBRATION FACTORS

DGM 1 1,0101  
 DGM 2 0,9873  
 DGM #3 0,9958

Paticulate concentration  
 Sample Train 1 **0,000040** g/dscf  
 Sample Train 2 **0,000037** g/dscf  
 Room **0,000002** g/dscf

TUNNEL FLOW RATE: 318,117 Dscfm

TOTAL EMISSIONS  
 Sample Train 1 **5,80** g  
 Sample Train 2 **5,25** g

PARTICULATE CATCH  
 Total Sample Train 1: 3,70 mg  
 Total Sample Train 2: 3,20 mg  
 Total Sample Train 1 1st hour: 2,30 mg

EMISSION RATES  
 Sample Train 1 **0,74** g/hr  
 Sample Train 2 **0,67** g/hr

1st hour emission rate **3,76** g/hr

DEVIATION: 5,00%

Cs Train 1 Train 2  
 4,034E-05 3,6656E-05

* Elapsed Time min	Raw data row	* Weight		* CO		* CO <sub>2</sub>		*1 Flue	*2 Room	*3 Tunnel	*4 Unit	*5 Unit	*6 Unit	*7 Unit	*8 Unit	Mass flow 1	DGM 1	DGM 1	Filter 1	Mass flow 2	DGM 2	DGM 2	Filter 2	
		Remaining	CO	CO <sub>2</sub>	Flue	Room	Tunnel	Unit	Unit	Unit	Unit	Unit	Unit	Unit	Unit	Unit	Reading	Inlet T	Outlet T	Temp	Reading	Inlet T	Outlet T	Temp
		lbs	%	%	°F	°F	°F	Top	Back	R.Side	L.Side	Bottom	°F	°F	°F	°F	cuft/min	oF	oF	oF	cuft/min	oF	oF	oF
0,00	182,00	21,4	0,2	4,9	415,5	71,5	112,9	640,5	490,9	510,5	529,5	312,9	0,19	77,66	77,84	85,04	0,19	78,61	78,48	84,10				
1,0	183,0	21,1	0,3	2,8	482,5	72,5	108,5	661,1	500,2	509,5	528,8	317,2	0,19	77,82	77,86	84,78	0,19	78,70	78,51	84,09				
2,0	184,0	20,9	0,3	6,2	522,4	72,2	109,6	691,6	508,8	508,3	508,3	321,5	0,19	77,96	77,96	84,54	0,19	78,75	78,56	84,13				
3,0	185,0	20,6	0,3	7,5	603,1	72,5	114,7	735,5	516,6	506,5	525,5	325,8	0,19	77,93	77,93	86,32	0,19	78,72	78,57	84,21				
4,0	186,0	20,4	0,4	11,8	653,0	71,9	119,5	788,6	523,3	504,6	523,7	329,9	0,19	77,88	77,95	85,93	0,19	78,73	78,61	84,24				
5,0	187,0	20,1	0,4	13,3	696,2	71,7	123,3	837,9	528,9	502,2	521,5	334,0	0,19	77,91	77,96	85,63	0,19	78,70	78,62	84,24				
6,0	188,0	19,7	0,5	14,2	739,4	72,2	127,0	882,7	533,5	499,2	519,1	337,5	0,19	78,08	78,01	85,31	0,19	78,83	78,66	84,26				
7,0	189,0	19,4	0,5	15,3	777,3	72,5	130,7	922,4	537,1	496,4	517,0	341,2	0,19	78,29	78,04	85,04	0,19	78,91	78,71	84,31				
8,0	190,0	19,1	0,4	16,3	796,0	72,3	133,9	955,7	493,7	515,4	515,4	344,8	0,19	78,49	78,09	84,78	0,19	79,10	78,77	84,36				
9,0	191,0	18,8	0,3	16,6	794,8	72,4	135,2	982,0	541,6	490,8	514,0	347,9	0,19	78,67	78,14	84,54	0,19	79,17	78,82	84,55				
10,0	192,0	18,5	0,3	16,2	785,7	72,0	135,3	1001,4	543,0	488,4	513,2	350,9	0,19	78,71	78,19	84,35	0,19	79,16	78,89	84,40				
11,0	193,0	18,4	0,3	15,6	778,7	73,0	135,4	1014,9	543,5	485,8	512,6	353,7	0,19	78,83	78,22	84,24	0,19	79,18	78,92	84,31				
12,0	194,0	18,0	0,3	15,2	760,8	72,4	133,4	1024,1	543,9	484,4	512,7	356,4	0,19	79,06	78,32	84,23	0,19	79,34	79,01	84,28				
13,0	195,0	17,7	0,3	14,9	714,2	72,7	126,2	1031,1	544,0	483,2	512,8	359,0	0,19	79,28	78,38	84,24	0,19	79,51	79,06	84,25				
14,0	196,0	17,8	0,7	15,8	644,2	72,5	118,1	1033,9	543,7	482,3	513,7	361,3	0,19	79,42	78,44	84,26	0,19	79,65	79,13	84,18				
15,0	197,0	17,3	0,2	16,5	577,9	72,9	111,3	1023,6	543,3	482,0	514,0	363,2	0,19	79,37	78,46	84,35	0,19	79,62	79,12	84,12				
16,0	198,0	17,2	0,2	16,1	543,6	73,0	108,5	1010,0	542,7	481,5	514,8	365,0	0,19	79,53	78,51	84,24	0,19	79,73	79,22	84,10				
17,0	199,0	17,0	0,6	15,1	519,3	73,0	107,5	995,9	541,9	481,8	515,5	366,6	0,19	79,85	78,63	84,23	0,19	79,95	79,27	84,09				
18,0	200,0	16,9	0,3	14,4	500,0	72,5	107,3	981,6	541,1	481,5	515,8	368,4	0,19	80,33	78,76	84,24	0,19	80,25	79,36	84,13				
19,0	201,0	16,8	0,3	14,0	485,0	72,7	107,7	967,8	540,3	481,2	516,2	369,9	0,19	80,74	78,90	84,26	0,19	80,52	79,48	84,21				
20,0	202,0	16,7	0,3	13,8	474,0	73,5	107,5	956,9	539,4	480,8	516,2	371,2	0,19	81,11	79,05	84,31	0,19	80,81	79,57	84,24				
21,0	203,0	16,5	0,5	13,6	465,6	73,2	107,4	948,7	538,4	480,2	515,8	372,4	0,19	81,40	79,20	84,29	0,19	81,08	79,71	84,24				
22,0	204,0	16,4	0,7	13,4	460,2	73,4	107,0	942,9	537,3	479,0	515,5	373,2	0,19	81,66	79,36	84,32	0,19	81,35	79,86	84,26				
23,0	205,0	16,3	0,7	13,5	454,4	73,9	107,6	938,7	536,3	478,3	514,6	374,2	0,19	81,90	79,50	84,30	0,19	81,59	79,96	84,31				
24,0	206,0	16,1	0,9	13,3	450,5	73,3	107,8	934,4	535,1	477,5	513,4	374,9	0,19	82,19	79,65	84,32	0,19	81,86	80,11	84,36				
25,0	207,0	16,0	0,9	13,3	446,4	73,3	108,1	930,6	533,9	475,9	512,3	375,6	0,19	82,49	79,81	84,35	0,19	82,15	80,26	84,41				
26,0	208,0	15,9	0,9	13,3	443,7	73,5	107,7	927,2	532,6	474,5	511,3	376,1	0,19	82,72	79,97	84,37	0,19	82,40	80,41	84,43				
27,0	209,0	15,7	1,0	13,4	441,5	74,1	107,9	924,3	531,2	473,0	510,0	376,5	0,19	83,02	80,15	84,38	0,19	82,69	80,55	84,50				
28,0	210,0	15,5	0,9	13,6	439,7	73,1	107,7	921,7	529,8	471,7	508,5	376,8	0,19	83,28	80,33	84,36	0,19	82,95	80,74	84,51				
29,0	211,0	15,4	0,9	13,8	438,6	73,7	107,7	919,7	528,5	469,7	507,9	377,0	0,19	83,50	80,51	84,38	0,19	83,17	80,89	84,50				
30,0	212,0	15,2	0,9	13,9	436,8	73,8	106,8	917,6	527,0	468,3	505,6	377,1	0,19	83,61	80,64	84,34	0,19	83,38	81,05	84,54				
31,0	213,0	15,1	0,9	13,9	436,7	74,1	105,3	916,0	525,6	466,8	503,8	376,9	0,19	83,70	80,77	84,27	0,19	83,52	81,16	84,55				
32,0	214,0	15,0	0,9	13,9	435,8	73,5	104,3	914,5	524,1	464,9	502,5	377,1	0,19	83,67	80,84	84,33	0,19	83,63	81,25	84,53				
33,0	215,0	14,9	0,9	13,9	435,4	74,1	103,2	913,9	522,7	462,9	501,3	376,9	0,19	83,53	80,88	84,33	0,19	83,62	81,31	84,54				
34,0	216,0	14,7	0,9	13,9	434,6	73,3	103,0	912,3	521,2	461,5	499,9	376,9	0,19	83,33	80,89	84,31	0,19	83,56	81,35	84,56				
35,0	217,0	14,6	0,9	14,0	434,2	73,6	102,4	911,5	519,7	459,7	498,9	376,5	0,19	83,09	80,90	84,23	0,19	83,46	81,37	84,56				
36,0	218,0	14,4	0,9	14,0	432,7	73,3	102,0	910,9	518,3	457,1	497,6	376,2	0,19	82,82	80,89	84,19	0,19	83,27	81,36	84,53				
37,0	219,0	14,3	0,9	14,0	432,1	73,6	101,6	910,4	516,7	455,8	496,2	375,8	0,19	82,57	80,86	84,12	0,19	83,15	81,37	84,51				
38,0	220,0	14,2	0,9	14,0	431,5	73,4	101,1	909,6	515,3	454,1	495,2	375,4	0,19	82,38	80,82	84,10	0,19	83,02	81,35	84,47				
39,0	221,0	14,0	0,9	14,1	431,9	73,1	100,8	908,5	513,9	451,8	494,2	375,0	0,19	82,26	80,81	84,03	0,19	82,93	81,35	84,43				
40,0	222,0	13,9	0,9	14,3	432,9	74,2	100,5	907,9	512,4	450,1	493,2	373,8	0,19	82,10	80,78	83,96	0,19	82,83	81,33	84,34				
41,0	223,0	13,7	0,8	14,4	433,0	73,1	99,8	908,3	511,0	448,3	492,5	372,1	0,19	81,96	80,79	83,92	0,19	82,77	81,34	84,31				
42,0	224,0	13,6	0,8	14,4	433,0	73,1	100,3	908,9	509,6	446,8	491,6	371,2	0,19	81,89	80,75	83,85	0,19	82,70	81,32	84,23				
43,0	225,0	13,4	0,8	14,4	433,1	72,9	99,4	908,8	508,3	445,3	490,7	370,3	0,19	81,82	80,73	83,79	0,19	82,67	81,31	84,15				
44,0	226,0	13,3	0,7	14,4	432,7	73,4	99,6	908,8	507,1	443,1	490,0	369,7	0,19	81,82	80,73	83,72	0,19	82,68	81,32	84,08				
45,0	227,0	13,2	0,7	14,4	432,6	73,5	99,7	909,1	505,7	442,3	489,2	369,1	0,19	81,87	80,74	83,66	0,19	82,66	81,34	84,06				
46,0	228,0	13,1	0,7	14,4	432,5	74,1	99,3	909,1	504,4	440,3	489,0	367,1	0,19	81,95	80,73	83,60	0,19	82,61	81,35	83,99				
47,0	229,0	12,9	0,7	14,5	432,8	73,4	100,2	909,4	503,2	438,9	488,0	365,6	0,19	82,09	80,79	83,55	0,19	82,67	81,36	83,92				
48,0	230,0	12,8	0,7	14,5	432,0	73,3	101,9	909,9	502,2	437,7	487,6	361,5	0,19	82,44	80,92	83,49	0,19	82,82	81,44	83,89				
49,0	231,0	12,6	0,9	14,6	430,2	73,7	102,9	908,0	501,0	436,2	486,9	360,8	0,19	82,65	81,03	83,46	0,19	82,96	81,50	83,82				
50,0	232,0	12,5	1,0	14,4	429,1	73,9	103,6	906,2	499,9	435,0	486,5	359,8	0,19	82,88	81,16	83,43	0,19	83,12	81,62	83,84				
51,0	233,0	12,4	1,0	14,4	429,2	74,5	104,2	905,4	498,9	433,9	486,3	355,9	0,19	83,21	81,31	83,41	0,19	83,37	81,73	83,83				
52,0	234,0	12,2	1,1	14,6	428,3	74,1	104,6	904,9	498,0	432,8	485,6	352,3	0,19	83,50	81,45	83,39	0,19	83,59	81,86	83,85				
53,0	235,0	12,1	1,0	14,7	427,7	74,2	104,5	904,7	497,0	432,4	485,3	350,1	0,19	83,73	81,61	83,38	0,19	83,82	81,99	83,87				
54,0	236,0	11,9	1,1	14,7	427,5	74,3	103,4	904,4	496,0	431,4	484,5	345,0	0,19	83,83	81,70	83,35	0,19	83,91	82,10	83,89				
55,0	237,0	11,9	4,5	14,7	425,6	74,0	102,5	902,4	495,2	430,6	484,0	335,6	0,19	83,80	81,73	83,32	0,19	83,98	82,17	83,84				
56,0	238,0	11,7	0,7	14,2	421,8	73,6	101,4	902,5	494															

82,0	264,0	8,5	1,3	15,4	433,7	75,0	104,3	945,0	479,1	421,0	481,6	286,3	0,19	83,52	82,16	85,04	0,19	83,67	82,61	83,19
83,0	265,0	8,4	1,4	15,4	432,7	74,6	103,5	942,8	478,7	420,9	481,5	286,1	0,19	83,73	82,28	85,16	0,19	83,87	82,74	83,25
84,0	266,0	8,2	1,3	15,3	431,9	74,5	103,0	942,1	478,3	421,5	481,7	285,5	0,19	83,80	82,37	85,16	0,19	83,99	82,82	83,28
85,0	267,0	8,1	1,1	15,3	428,9	74,5	102,1	941,1	478,0	421,4	481,8	285,3	0,19	83,83	82,44	85,18	0,19	84,08	82,88	83,33
86,0	268,0	8,0	0,9	14,6	422,4	75,4	101,1	934,6	477,7	421,8	481,9	285,3	0,19	83,60	82,48	85,19	0,19	84,02	82,93	83,35
87,0	269,0	7,9	1,3	13,3	420,0	75,2	100,7	929,5	477,3	422,3	482,0	287,0	0,19	83,41	82,46	85,13	0,19	83,91	82,93	83,33
88,0	270,0	7,8	1,2	13,3	418,1	74,9	100,3	924,2	477,1	422,8	482,2	285,3	0,19	83,34	82,48	85,13	0,19	83,85	82,94	83,38
89,0	271,0	7,7	1,1	13,2	415,7	75,2	99,6	921,3	476,9	423,1	482,1	280,4	0,19	83,29	82,50	85,12	0,19	83,88	82,98	83,39
90,0	272,0	7,6	1,0	13,1	411,7	74,6	99,0	914,3	476,6	423,4	482,4	273,5	0,19	83,18	82,48	85,04	0,19	83,86	82,98	83,37
91,0	273,0	7,5	0,8	12,8	406,7	75,3	98,9	904,7	476,5	423,9	482,0	269,0	0,19	83,06	82,48	85,00	0,19	83,75	82,98	83,38
92,0	274,0	7,4	0,8	12,5	402,6	75,3	98,7	895,6	476,3	423,9	482,7	265,8	0,19	82,97	82,48	84,98	0,19	83,71	82,97	83,38
93,0	275,0	7,3	0,8	12,2	399,5	74,7	98,5	887,5	476,2	424,4	482,8	258,2	0,19	82,75	82,48	84,98	0,19	83,56	83,00	83,39
94,0	276,0	7,3	0,8	12,0	396,7	75,0	97,7	881,7	476,1	423,9	483,6	254,9	0,19	82,56	82,48	84,93	0,19	83,42	82,96	83,37
95,0	277,0	7,1	0,8	12,0	393,4	74,2	97,2	875,2	475,9	424,4	483,6	254,5	0,19	82,44	82,49	84,83	0,19	83,29	82,97	83,35
96,0	278,0	7,0	0,8	11,7	388,0	74,0	97,0	865,3	475,9	425,2	483,6	253,9	0,19	82,27	82,46	84,75	0,19	83,18	82,95	83,36
97,0	279,0	7,0	0,8	11,4	383,1	74,4	96,9	854,2	475,8	425,5	483,6	250,9	0,19	82,12	82,42	84,72	0,19	83,02	82,93	83,37
98,0	280,0	6,9	0,9	11,2	379,0	75,0	96,4	844,2	475,8	425,9	483,5	249,2	0,19	81,98	82,40	84,64	0,19	82,91	82,90	83,32
99,0	281,0	6,8	0,9	11,3	376,8	74,9	96,0	835,9	475,8	426,3	483,4	246,7	0,19	81,88	82,35	84,59	0,19	82,80	82,88	83,26
100,0	282,0	6,7	0,9	11,3	375,6	74,1	96,1	829,5	475,8	426,5	483,4	244,9	0,19	81,80	82,30	84,49	0,19	82,70	82,85	83,21
101,0	283,0	6,7	0,9	11,5	375,5	74,6	95,9	824,9	476,0	426,3	483,2	243,7	0,19	81,71	82,25	84,47	0,19	82,60	82,84	83,21
102,0	284,0	6,5	0,9	11,7	377,2	74,6	95,9	822,5	476,0	427,0	482,7	243,0	0,19	81,62	82,21	84,41	0,19	82,49	82,80	83,17
103,0	285,0	6,5	0,9	11,9	378,2	74,7	95,8	821,5	476,2	427,0	482,0	242,2	0,19	81,56	82,18	84,34	0,19	82,40	82,74	83,12
104,0	286,0	6,4	0,9	12,2	379,3	75,2	95,7	821,5	476,4	427,0	482,0	241,2	0,19	81,50	82,15	84,27	0,19	82,37	82,74	83,09
105,0	287,0	6,3	0,9	12,4	377,9	74,2	95,4	820,8	476,6	427,5	481,8	240,9	0,19	81,47	82,15	84,23	0,19	82,31	82,74	83,08
106,0	288,0	6,2	0,8	12,2	377,2	74,3	95,7	819,3	476,7	427,7	481,6	240,8	0,19	81,44	82,10	84,18	0,19	82,25	82,69	83,01
107,0	289,0	6,1	0,8	12,3	377,0	74,7	95,4	818,0	477,0	427,4	481,1	240,6	0,19	81,44	82,07	84,13	0,19	82,18	82,66	82,99
108,0	290,0	6,0	0,8	12,3	375,3	74,3	95,3	817,6	477,1	427,9	481,0	240,3	0,19	81,38	82,05	84,07	0,19	82,14	82,64	82,95
109,0	291,0	5,9	0,8	12,0	373,3	74,9	95,2	816,5	477,3	428,1	480,7	240,3	0,19	81,30	82,02	83,98	0,19	82,12	82,65	82,88
110,0	292,0	5,9	0,7	11,9	371,4	74,7	95,0	814,1	477,5	428,1	480,6	239,9	0,19	81,30	82,00	83,94	0,19	82,15	82,64	82,84
111,0	293,0	5,8	0,7	11,7	368,8	74,3	95,4	810,6	477,7	428,5	480,2	239,7	0,19	81,27	81,98	83,89	0,19	82,09	82,62	82,79
112,0	294,0	5,7	0,7	11,8	369,9	74,3	95,0	808,7	477,8	428,1	480,2	239,7	0,19	81,25	81,96	83,83	0,19	82,08	82,59	82,76
113,0	295,0	5,6	0,6	12,1	370,2	74,5	94,3	807,9	478,1	428,4	480,1	239,3	0,19	81,22	81,91	83,75	0,19	82,03	82,57	82,71
114,0	296,0	5,6	0,6	12,2	370,7	74,7	94,9	808,3	478,3	428,7	479,7	238,9	0,19	81,18	81,91	83,67	0,19	81,99	82,53	82,65
115,0	297,0	5,5	0,8	12,4	371,9	74,9	94,6	809,8	478,7	428,8	480,0	238,7	0,19	81,13	81,88	83,64	0,19	81,97	82,52	82,63
116,0	298,0	5,4	0,8	12,6	369,7	74,4	94,7	810,3	479,0	428,6	479,7	238,1	0,19	81,15	81,86	83,61	0,19	81,96	82,48	82,61
117,0	299,0	5,4	0,7	12,3	367,2	74,2	94,4	807,7	479,3	429,0	479,9	238,0	0,19	81,11	81,85	83,53	0,19	81,94	82,48	82,55
118,0	300,0	5,3	0,7	11,9	363,0	74,3	94,1	804,8	479,6	429,0	480,1	238,0	0,19	81,15	81,83	83,44	0,19	81,95	82,44	82,54
119,0	301,0	5,2	0,6	11,7	359,2	74,4	94,3	800,4	480,0	429,7	480,3	237,8	0,19	81,19	81,78	83,39	0,19	81,94	82,44	82,52
120,0	302,0	5,2	0,4	11,2	353,7	74,6	93,5	796,8	480,4	430,0	480,5	237,5	0,19	81,24	81,77	83,33	0,19	81,93	82,41	82,51
121,0	303,0	5,1	0,3	10,2	347,6	74,4	93,4	789,8	480,8	430,0	480,7	237,2	0,19	81,27	81,77	83,26	0,19	81,94	82,41	82,45
122,0	304,0	5,1	0,3	9,3	341,9	74,8	93,1	780,2	481,2	429,9	480,8	236,8	0,19	81,25	81,74	83,14	0,19	81,92	82,41	82,38
123,0	305,0	5,0	0,3	9,1	336,9	74,4	92,8	770,6	481,5	430,2	481,0	236,4	0,19	81,19	81,73	83,09	0,19	81,89	82,38	82,31
124,0	306,0	5,0	0,3	9,0	332,6	74,6	92,2	761,3	482,1	430,5	480,9	236,3	0,19	81,18	81,72	83,01	0,19	81,88	82,39	82,27
125,0	307,0	4,9	0,3	9,0	329,4	74,2	91,6	753,0	482,6	430,8	480,8	235,9	0,19	81,19	81,71	82,95	0,19	81,92	82,38	82,21
126,0	308,0	4,9	0,4	8,9	326,4	74,5	91,4	745,8	483,1	431,0	481,2	235,7	0,19	81,09	81,67	82,85	0,19	81,83	82,36	82,15
127,0	309,0	4,9	0,4	8,9	323,5	74,5	91,4	738,8	483,6	430,9	481,1	235,2	0,19	80,94	81,64	82,77	0,19	81,79	82,35	82,07
128,0	310,0	4,9	0,4	8,9	320,3	74,2	91,4	732,3	484,2	431,0	480,9	235,1	0,19	80,83	81,63	82,70	0,19	81,69	82,33	81,96
129,0	311,0	4,9	0,4	8,8	317,8	73,7	91,5	725,8	484,8	430,6	480,8	234,5	0,19	80,78	81,58	82,66	0,19	81,63	82,31	81,91
130,0	312,0	4,8	0,4	8,8	315,8	74,0	91,0	719,4	485,5	431,0	480,5	234,2	0,19	80,77	81,56	82,58	0,19	81,59	82,26	81,89
131,0	313,0	4,7	0,4	8,8	313,1	74,9	90,9	712,9	486,2	430,8	480,2	233,6	0,19	80,87	81,56	82,50	0,19	81,68	82,25	81,83
132,0	314,0	4,7	0,4	8,6	309,8	74,8	92,1	706,8	486,9	430,7	479,4	233,4	0,19	81,07	81,61	82,48	0,19	81,80	82,26	81,80
133,0	315,0	4,7	0,5	8,5	307,1	74,5	93,2	700,7	487,5	431,0	479,0	233,7	0,19	81,52	81,72	82,50	0,19	82,05	82,32	81,74
134,0	316,0	4,7	0,5	8,5	304,7	75,0	95,0	694,7	488,2	430,6	479,0	233,5	0,19	81,92	81,82	82,54	0,19	82,29	82,40	81,72
135,0	317,0	4,6	0,5	8,5	302,3	75,1	95,9	689,3	488,8	430,5	478,5	233,7	0,19	82,21	81,93	82,65	0,19	82,54	82,48	81,75
136,0	318,0	4,6	0,4	8,4	300,5	74,6	95,9	684,0	489,3	430,4	477,7	233,7	0,19	82,52	82,03	82,79	0,19	82,81	82,57	81,78
137,0	319,0	4,5	0,4	8,4	298,9	75,1	94,9	679,4	489,9	430,2	477,2	233,7	0,19	82,67	82,11	82,83	0,19	82,97	82,65	81,81
138,0	320,0	4,5	0,3	8,3	296,3	74,7	94,0	674,1	490,3	430,2	477,0	233,7	0,19	82,71	82,18	82,81	0,19	83,10	82,71	81,82
139,0	321,0	4,5	0,4	8,0	293,6	74,5	93,3	668,9	490,8	429,9	476,2	233,7	0,19	82,63	82,19	82,77	0,19	83,10	82,73	81,78
140,0	322,0	4,5	0,4	7,6	290,1	74,6	92,7	662,9	491,0	429,7	475,6	233,7	0,19	82,56	82,20	82,74	0,19	83,09	82,75	81,77
141,0	323,0	4,5	0,5	7,0	287,1	75,1	92,7	656,0	491,2	429,5	474,9	233,3	0,19	82,55	82,24	82,70				

168,0	350,0	4,0	1,3	5,6	236,4	74,9	91,4	524,2	485,6	412,5	450,6	232,5	0,19	83,36	83,38	82,85	0,19	84,32	83,93	82,14
169,0	351,0	4,0	1,4	5,5	234,7	75,3	92,6	520,7	485,4	411,5	449,8	232,6	0,19	83,62	83,46	82,89	0,19	84,44	83,94	82,12
170,0	352,0	4,0	1,3	5,6	232,6	75,8	93,6	517,4	485,2	410,7	448,6	232,2	0,19	83,90	83,56	82,96	0,19	84,61	84,02	82,11
171,0	353,0	3,9	1,2	5,8	230,8	75,2	94,9	514,1	485,0	409,6	448,2	232,3	0,19	84,12	83,69	83,06	0,19	84,77	84,07	82,13
172,0	354,0	3,9	1,1	5,8	229,5	75,0	95,7	510,9	484,7	408,9	448,1	232,5	0,19	84,33	83,78	83,14	0,19	84,95	84,17	82,14
173,0	355,0	3,9	1,1	5,9	228,3	76,0	96,4	507,9	484,3	408,0	447,7	232,5	0,19	84,59	83,90	83,25	0,19	85,18	84,30	82,18
174,0	356,0	3,9	1,1	5,9	227,3	75,2	96,2	504,9	483,9	407,0	446,5	232,3	0,19	84,84	84,03	83,33	0,19	85,40	84,42	82,22
175,0	357,0	3,9	1,1	5,9	226,6	75,7	95,0	502,2	483,6	406,3	445,6	232,3	0,19	84,99	84,11	83,34	0,19	85,55	84,51	82,23
176,0	358,0	3,8	1,1	5,9	226,1	75,7	94,2	499,7	483,3	405,5	445,6	232,1	0,19	85,00	84,18	83,31	0,19	85,59	84,56	82,23
177,0	359,0	3,9	1,1	5,9	225,9	75,2	93,1	497,1	483,0	404,1	444,8	232,2	0,19	84,90	84,20	83,30	0,19	85,56	84,59	82,26
178,0	360,0	3,8	1,1	5,9	225,5	75,3	92,2	494,8	482,7	403,6	443,9	232,4	0,19	84,79	84,19	83,27	0,19	85,49	84,61	82,27
179,0	361,0	3,8	1,1	5,9	225,0	75,7	91,9	492,6	482,4	402,6	443,0	232,1	0,19	84,64	84,21	83,20	0,19	85,47	84,63	82,24
180,0	362,0	3,8	1,1	6,0	224,6	75,5	91,9	490,7	482,2	401,6	442,6	232,3	0,19	84,46	84,18	83,14	0,19	85,41	84,62	82,23
181,0	363,0	3,8	1,1	6,1	223,9	75,9	90,9	488,8	481,9	400,7	441,7	232,3	0,19	84,27	84,17	83,04	0,19	85,29	84,61	82,20
182,0	364,0	3,8	1,0	6,2	223,6	75,7	90,5	487,1	481,6	399,5	441,1	232,1	0,19	84,13	84,15	82,99	0,19	85,20	84,59	82,14
183,0	365,0	3,8	1,0	6,5	223,3	75,2	90,3	485,8	481,3	398,6	440,4	232,2	0,19	83,98	84,10	82,91	0,19	85,10	84,60	82,12
184,0	366,0	3,8	1,0	6,4	223,6	75,7	89,8	484,8	481,0	397,8	440,0	232,1	0,19	83,83	84,07	82,87	0,19	84,96	84,57	82,10
185,0	367,0	3,7	1,0	6,4	223,3	75,4	89,6	484,0	480,6	397,0	439,0	232,1	0,19	83,68	84,00	82,78	0,19	84,81	84,51	82,07
186,0	368,0	3,7	1,0	6,4	223,0	75,8	89,5	483,3	480,3	395,7	438,2	232,0	0,19	83,62	83,97	82,72	0,19	84,73	84,51	82,05
187,0	369,0	3,7	1,0	6,5	222,8	75,2	89,3	482,8	480,0	394,9	437,6	231,8	0,19	83,51	83,93	82,63	0,19	84,61	84,48	82,02
188,0	370,0	3,7	1,0	6,5	223,3	75,7	89,0	482,4	479,4	394,0	436,8	231,7	0,19	83,42	83,89	82,55	0,19	84,53	84,44	81,96
189,0	371,0	3,7	1,0	6,6	223,0	75,5	88,8	482,3	479,1	393,2	436,8	231,7	0,19	83,30	83,82	82,48	0,19	84,43	84,41	81,91
190,0	372,0	3,6	0,9	6,6	222,7	75,6	88,6	482,1	478,7	392,5	436,4	231,7	0,19	83,24	83,77	82,40	0,19	84,30	84,38	81,85
191,0	373,0	3,6	0,9	6,7	222,9	75,5	88,5	482,1	478,4	392,0	436,0	231,8	0,19	83,17	83,74	82,36	0,19	84,28	84,35	81,84
192,0	374,0	3,6	0,9	6,7	222,7	75,3	88,5	482,1	478,0	391,2	435,6	231,7	0,19	83,11	83,71	82,27	0,19	84,23	84,31	81,80
193,0	375,0	3,6	0,9	6,7	222,4	75,4	88,1	481,9	477,6	390,3	435,3	231,7	0,19	82,99	83,65	82,22	0,19	84,11	84,28	81,72
194,0	376,0	3,6	0,9	6,6	222,5	75,9	88,5	481,6	477,3	389,6	435,2	231,9	0,19	82,94	83,63	82,15	0,19	84,07	84,24	81,70
195,0	377,0	3,5	0,9	6,6	222,3	75,2	88,9	481,4	476,9	388,9	434,9	231,8	0,19	83,00	83,68	82,16	0,19	84,10	84,27	81,67
196,0	378,0	3,6	1,1	6,6	221,4	75,6	91,0	481,3	476,6	388,0	433,6	231,7	0,19	83,32	83,74	82,19	0,19	84,24	84,28	81,63
197,0	379,0	3,6	1,0	6,7	220,9	75,6	92,5	481,3	476,3	387,3	433,8	231,6	0,19	83,58	83,84	82,25	0,19	84,37	84,33	81,64
198,0	380,0	3,5	1,0	6,8	220,4	75,6	93,5	481,1	476,0	386,8	433,5	231,6	0,19	83,83	83,93	82,36	0,19	84,58	84,41	81,66
199,0	381,0	3,5	1,0	6,8	219,7	75,3	94,3	481,0	475,9	386,6	432,9	231,7	0,19	84,05	84,03	82,47	0,19	84,74	84,48	81,66
200,0	382,0	3,5	1,0	6,8	219,3	75,6	95,2	480,7	475,5	386,1	432,9	231,5	0,19	84,29	84,15	82,54	0,19	84,98	84,59	81,69
201,0	383,0	3,5	1,0	6,8	219,0	75,8	96,1	480,3	475,2	385,3	431,8	231,5	0,19	84,51	84,26	82,65	0,19	85,18	84,71	81,70
202,0	384,0	3,5	1,0	6,8	218,4	75,8	96,7	479,8	475,1	384,9	431,9	231,4	0,19	84,71	84,39	82,77	0,19	85,38	84,81	81,73
203,0	385,0	3,4	1,0	6,8	218,3	76,0	97,2	479,5	475,0	384,6	431,5	231,4	0,19	84,96	84,51	82,89	0,19	85,59	84,94	81,75
204,0	386,0	3,4	1,0	6,8	218,1	75,7	96,5	479,0	474,8	384,2	431,0	231,4	0,19	85,16	84,63	83,02	0,19	85,78	85,05	81,80
205,0	387,0	3,4	1,0	6,8	217,8	76,0	95,3	478,5	474,6	383,7	430,3	231,0	0,19	85,25	84,70	83,05	0,19	85,88	85,11	81,84
206,0	388,0	3,4	1,0	6,8	218,0	75,5	94,0	478,1	474,5	383,3	429,9	231,1	0,19	85,25	84,74	83,04	0,19	85,91	85,17	81,84
207,0	389,0	3,4	1,0	6,7	218,2	76,0	93,1	477,6	474,4	382,8	429,4	231,1	0,19	85,14	84,76	83,04	0,19	85,87	85,18	81,88
208,0	390,0	3,4	1,0	6,7	218,6	76,3	92,3	477,1	474,4	382,5	428,8	231,0	0,19	84,97	84,76	83,04	0,19	85,81	85,19	81,90
209,0	391,0	3,3	1,0	6,7	218,7	76,1	91,7	476,8	474,4	382,1	428,1	230,8	0,19	84,80	84,76	83,01	0,19	85,75	85,20	81,92
210,0	392,0	3,3	1,0	6,7	218,6	75,6	91,1	476,2	474,4	381,9	427,4	230,8	0,19	84,63	84,73	82,96	0,19	85,66	85,17	81,91
211,0	393,0	3,3	1,1	6,6	218,7	76,0	90,8	475,5	474,4	381,6	426,7	230,7	0,19	84,42	84,68	82,94	0,19	85,53	85,18	81,94
212,0	394,0	3,3	1,0	6,7	219,0	75,7	90,3	475,1	474,4	380,7	426,4	230,7	0,19	84,25	84,64	82,91	0,19	85,40	85,14	81,94
213,0	395,0	3,3	1,0	6,7	218,7	75,7	89,9	474,8	474,5	380,2	426,0	230,6	0,19	84,04	84,59	82,83	0,19	85,22	85,11	81,93
214,0	396,0	3,2	1,0	6,7	219,2	75,8	89,7	474,6	474,6	379,9	425,0	230,4	0,19	83,84	84,53	82,79	0,19	85,09	85,06	81,91
215,0	397,0	3,3	1,0	6,7	219,1	75,8	89,2	474,5	474,4	379,4	424,7	230,5	0,19	83,59	84,47	82,74	0,19	84,88	84,91	81,91
216,0	398,0	3,2	1,0	6,7	219,2	75,2	88,9	474,2	474,4	379,2	424,5	230,6	0,19	83,46	84,43	82,63	0,19	84,72	84,97	81,87
217,0	399,0	3,2	1,0	6,7	219,1	75,5	89,1	473,9	474,5	378,7	423,4	230,3	0,19	83,28	84,36	82,60	0,19	84,56	84,91	81,87
218,0	400,0	3,2	1,0	6,7	218,9	75,9	88,7	473,7	474,4	378,5	423,5	230,3	0,19	83,17	84,32	82,56	0,19	84,46	84,87	81,84
219,0	401,0	3,2	1,0	6,6	218,7	75,9	88,5	473,5	474,4	377,7	422,8	230,2	0,19	83,04	84,23	82,49	0,19	84,35	84,84	81,81
220,0	402,0	3,2	1,0	6,6	218,8	75,7	88,6	473,1	474,4	377,6	421,8	229,9	0,19	82,97	84,20	82,47	0,19	84,31	84,83	81,80
221,0	403,0	3,2	1,0	6,7	218,1	76,3	89,0	472,7	474,2	376,9	421,8	229,9	0,19	82,86	84,17	82,40	0,19	84,21	84,78	81,78
222,0	404,0	3,2	0,9	6,7	217,7	75,3	90,5	472,5	474,2	376,6	421,5	229,8	0,19	82,96	84,18	82,40	0,19	84,22	84,77	81,76
223,0	405,0	3,1	0,9	6,7	217,1	75,5	91,6	472,4	474,2	376,1	421,2	229,8	0,19	83,18	84,26	82,47	0,19	84,34	84,80	81,75
224,0	406,0	3,1	0,9	6,7	216,7	75,7	92,9	472,2	474,0	375,7	420,7	229,7	0,19	83,35	84,34	82,54	0,19	84,46	84,85	81,75
225,0	407,0	3,1	0,9	6,7	216,1	75,7	93,8	472,1	473,9	375,8	420,2	229,7	0,19	83,55	84,41	82,64	0,19	84,61	84,93	81,76
226,0	408,0	3,1	0,9	6,8	216,2	75,8	94,7	472,0	473,8	375,0	420,1	229,7	0,19	83,75	84,51	82,73	0,19	84,72	85,01	81,80
227,0	409,0	3,1	1,0	6,7	216,1	76,0	95,6	471,8	473,6	374,7	419,8	229,6	0,19	84,01	84,59	82,84	0,19	84,92	85,08	

254,0	436,0	2,7	1,1	6,3	214,4	76,2	95,6	466,2	471,5	366,3	412,7	229,2	0,19	83,05	84,49	82,81	0,19	83,91	84,94	81,75
255,0	437,0	2,6	1,1	6,4	214,2	76,1	95,9	465,7	471,4	366,4	412,4	229,1	0,19	83,29	84,58	82,90	0,19	84,11	85,01	81,78
256,0	438,0	2,7	1,1	6,3	214,7	76,7	94,7	465,0	471,4	366,4	411,2	229,0	0,19	83,45	84,66	82,94	0,19	84,25	85,11	81,81
257,0	439,0	2,6	1,1	6,3	215,2	75,8	93,3	464,7	471,3	365,9	411,1	228,9	0,19	83,50	84,71	82,94	0,19	84,32	85,17	81,81
258,0	440,0	2,6	1,1	6,4	215,2	75,8	92,4	464,3	471,2	365,6	410,5	228,9	0,19	83,47	84,71	82,88	0,19	84,32	85,19	81,83
259,0	441,0	2,6	1,1	6,3	215,4	76,5	91,5	464,0	471,1	365,4	410,3	228,8	0,19	83,34	84,69	82,87	0,19	84,26	85,18	81,86
260,0	442,0	2,6	1,1	6,3	215,5	76,5	91,0	463,7	471,0	365,1	409,9	228,8	0,19	83,22	84,67	82,88	0,19	84,21	85,14	81,87
261,0	443,0	2,6	1,1	6,4	215,6	76,0	90,5	463,4	470,9	365,1	409,4	228,7	0,19	83,06	84,62	82,84	0,19	84,12	85,11	81,86
262,0	444,0	2,5	1,1	6,3	215,7	76,1	90,1	463,0	470,8	364,7	408,6	228,7	0,19	82,92	84,57	82,80	0,19	84,03	85,08	81,87
263,0	445,0	2,5	1,2	6,4	215,8	76,0	89,5	462,6	470,6	364,6	408,1	228,7	0,19	82,76	84,52	82,77	0,19	83,92	85,03	81,86
264,0	446,0	2,6	1,2	6,3	215,9	76,6	89,2	462,3	470,5	364,4	407,4	228,8	0,19	82,55	84,45	82,71	0,19	83,78	84,99	81,87
265,0	447,0	2,5	1,2	6,3	215,2	75,6	89,0	461,5	470,4	364,3	406,7	228,8	0,19	82,39	84,38	82,67	0,19	83,61	84,91	81,82
266,0	448,0	2,5	1,1	6,1	214,8	75,8	88,5	460,6	470,3	364,0	406,2	228,8	0,19	82,26	84,30	82,58	0,19	83,51	84,84	81,79
267,0	449,0	2,5	1,1	6,1	214,5	75,3	88,2	459,7	470,2	363,4	405,3	228,7	0,19	82,09	84,22	82,51	0,19	83,35	84,80	81,78
268,0	450,0	2,5	1,2	6,0	214,4	75,7	87,7	458,9	470,2	363,3	404,5	227,7	0,19	81,99	84,14	82,44	0,19	83,22	84,72	81,75
269,0	451,0	2,5	1,0	6,2	213,5	76,3	87,9	458,1	469,9	363,0	404,3	228,0	0,19	81,74	84,08	82,39	0,19	83,09	84,66	81,69
270,0	452,0	2,4	0,9	5,8	213,3	76,1	87,9	457,2	469,9	363,0	403,7	228,6	0,19	81,58	84,00	82,32	0,19	82,96	84,60	81,64
271,0	453,0	2,5	0,9	5,8	213,0	76,0	87,7	456,4	469,7	362,6	403,1	228,6	0,19	81,53	83,94	82,24	0,19	82,89	84,57	81,60
272,0	454,0	2,4	0,9	5,8	213,0	75,9	87,8	455,6	469,5	362,5	402,6	228,5	0,19	81,47	83,89	82,19	0,19	82,81	84,51	81,57
273,0	455,0	2,4	1,0	5,8	212,8	75,8	87,4	455,0	469,3	361,8	401,8	228,6	0,19	81,37	83,82	82,14	0,19	82,72	84,44	81,56
274,0	456,0	2,4	1,0	5,8	212,7	76,3	88,5	454,5	469,0	361,7	401,1	228,0	0,19	81,36	83,76	82,12	0,19	82,70	84,39	81,52
275,0	457,0	2,4	1,0	5,8	211,9	75,5	89,7	453,8	468,8	361,5	400,9	228,4	0,19	81,51	83,79	82,12	0,19	82,76	84,38	81,52
276,0	458,0	2,4	1,0	5,9	211,2	76,3	91,4	453,1	468,4	361,6	400,5	228,4	0,19	81,81	83,85	82,20	0,19	82,91	84,41	81,51
277,0	459,0	2,4	1,0	5,9	210,7	76,5	92,8	452,6	468,2	361,2	399,4	228,3	0,19	82,07	83,91	82,29	0,19	83,07	84,45	81,52
278,0	460,0	2,4	1,0	5,9	210,1	76,0	93,8	452,0	467,8	361,1	399,5	228,5	0,19	82,31	84,01	82,42	0,19	83,25	84,52	81,53
279,0	461,0	2,3	1,0	6,0	209,6	76,2	94,8	451,3	467,4	360,6	399,0	228,4	0,19	82,50	84,11	82,51	0,19	83,39	84,60	81,56
280,0	462,0	2,3	1,0	6,0	209,1	75,9	95,8	450,8	467,1	360,6	398,6	228,4	0,19	82,74	84,21	82,64	0,19	83,57	84,68	81,58
281,0	463,0	2,3	1,0	6,0	208,3	76,5	95,6	450,5	466,8	360,5	397,9	228,3	0,19	82,95	84,31	82,76	0,19	83,75	84,75	81,61
282,0	464,0	2,3	0,9	6,0	208,6	76,6	94,5	450,0	466,4	360,5	397,2	228,2	0,19	83,10	84,37	82,83	0,19	83,88	84,82	81,66
283,0	465,0	2,3	0,9	6,0	208,7	75,6	93,2	449,7	466,0	360,1	397,0	228,1	0,19	83,14	84,41	82,83	0,19	83,95	84,86	81,66
284,0	466,0	2,3	0,9	6,0	208,7	76,4	92,2	449,2	465,6	359,8	396,1	227,9	0,19	83,10	84,41	82,83	0,19	83,95	84,89	81,69
285,0	467,0	2,3	1,0	5,9	208,9	76,3	91,1	448,7	465,2	360,0	395,9	228,0	0,19	82,97	84,40	82,81	0,19	83,90	84,85	81,68
286,0	468,0	2,3	0,9	6,0	209,2	75,9	90,5	448,3	464,7	359,4	395,5	228,1	0,19	82,82	84,35	82,76	0,19	83,83	84,85	81,70
287,0	469,0	2,2	0,9	6,0	209,3	75,7	90,0	447,7	464,4	359,3	394,5	228,0	0,19	82,65	84,32	82,74	0,19	83,72	84,81	81,69
288,0	470,0	2,2	0,9	6,0	209,1	75,9	89,8	447,4	464,0	358,9	394,1	227,9	0,19	82,49	84,27	82,70	0,19	83,62	84,76	81,67
289,0	471,0	2,2	0,9	6,0	209,0	75,8	89,2	447,1	463,5	358,8	393,4	227,9	0,19	82,35	84,22	82,67	0,19	83,54	84,73	81,71
290,0	472,0	2,2	0,9	6,0	209,3	76,2	89,0	446,9	463,1	358,7	392,8	227,7	0,19	82,17	84,15	82,59	0,19	83,38	84,65	81,68
291,0	473,0	2,2	0,9	6,0	209,3	76,0	88,6	446,5	462,7	358,3	392,6	227,6	0,19	82,02	84,10	82,51	0,19	83,26	84,60	81,66
292,0	474,0	2,2	0,9	6,0	209,6	76,0	88,5	446,1	462,3	358,0	391,8	227,6	0,19	81,91	84,02	82,49	0,19	83,16	84,55	81,65
293,0	475,0	2,1	0,9	6,1	209,6	75,4	88,2	445,6	461,9	358,2	391,4	227,7	0,19	81,81	83,95	82,45	0,19	83,09	84,51	81,64
294,0	476,0	2,2	1,0	5,9	209,5	75,8	88,0	445,2	461,6	357,4	390,9	227,6	0,19	81,74	83,90	82,41	0,19	83,05	84,45	81,62
295,0	477,0	2,1	1,0	6,0	209,3	76,1	87,8	444,8	461,2	357,5	390,3	227,2	0,19	81,66	83,82	82,39	0,19	82,99	84,40	81,60
296,0	478,0	2,1	1,0	6,0	209,2	75,7	87,9	444,4	460,9	356,9	389,8	227,0	0,19	81,56	83,75	82,30	0,19	82,89	84,32	81,56
297,0	479,0	2,1	1,0	6,1	209,4	76,1	87,9	444,0	460,6	356,6	389,1	226,7	0,19	81,43	83,68	82,23	0,19	82,80	84,26	81,55
298,0	480,0	2,1	1,0	6,1	208,9	75,9	88,9	443,9	460,3	356,6	388,2	226,3	0,19	81,51	83,68	82,23	0,19	82,80	84,22	81,52
299,0	481,0	2,1	1,0	6,1	208,6	76,1	90,0	443,7	460,2	355,9	388,1	226,2	0,19	81,77	83,70	82,27	0,19	82,85	84,22	81,52
300,0	482,0	2,1	1,0	6,1	207,9	76,0	92,0	443,5	459,8	355,7	387,6	226,4	0,19	81,99	83,72	82,30	0,19	82,98	84,25	81,48
301,0	483,0	2,0	0,2	6,2	207,4	75,8	93,1	443,3	459,8	355,7	386,7	226,5	0,19	82,15	83,79	82,41	0,19	83,09	84,28	81,52
302,0	484,0	2,0	0,2	6,2	207,3	76,1	94,4	443,1	459,5	355,5	386,7	226,3	0,19	82,32	83,86	82,51	0,19	83,29	84,33	81,53
303,0	485,0	2,0	0,2	6,2	207,0	76,3	95,5	442,8	459,5	355,3	385,2	226,0	0,19	82,52	83,93	82,55	0,19	83,37	84,38	81,58
304,0	486,0	2,0	0,2	6,2	206,8	75,8	96,4	442,7	459,3	355,1	385,9	225,8	0,19	82,72	84,04	82,76	0,19	83,54	84,45	81,57
305,0	487,0	2,0	0,2	6,2	206,4	76,1	97,5	442,5	459,2	354,9	385,4	225,5	0,19	82,96	84,16	82,87	0,19	83,73	84,56	81,60
306,0	488,0	2,0	0,2	6,2	206,3	76,4	97,9	442,3	459,2	354,9	384,7	225,4	0,19	83,20	84,29	83,01	0,19	83,95	84,65	81,65
307,0	489,0	1,9	0,2	6,2	206,3	76,5	98,4	442,0	459,1	354,8	384,5	225,2	0,19	83,42	84,41	83,15	0,19	84,13	84,73	81,71
308,0	490,0	1,9	0,2	6,2	206,1	76,6	99,0	441,9	459,0	354,7	383,8	225,2	0,19	83,62	84,53	83,29	0,19	84,35	84,83	81,75
309,0	491,0	1,9	0,2	6,2	205,6	76,6	99,6	441,7	458,9	354,4	383,4	224,9	0,19	83,84	84,68	83,45	0,19	84,53	84,94	81,82
310,0	492,0	1,9	0,2	6,2	205,3	76,6	99,8	441,3	458,8	354,3	383,1	224,7	0,19	84,01	84,81	83,58	0,19	84,72	85,04	81,87
311,0	493,0	1,9	0,2	6,2	205,4	76,5	100,1	441,0	458,8	354,0	382,8	224,6	0,19	84,19	84,96	83,73	0,19	84,92	85,14	81,92
312,0	494,0	1,9	0,2	6,3	205,4	76,6	100,1	440,9	458,7	353,9	382,6	224,3	0,19	84,39	85,10	83,87	0,19	85,11	85,26	82,02
313,0	495,0	1,9	0,2	6,3	205,5	76,6	100,8	440,6	458,7	353,9	382,0	224,2	0,19	84,55	85,25	83,99	0,19	85,29	85	

340,0	522,0	1,6	0,2	5,8	206,8	77,0	93,6	437,5	454,0	350,1	372,7	222,3	0,19	84,58	85,67	84,60	0,19	85,69	85,87	83,03
341,0	523,0	1,5	0,2	5,8	207,2	76,8	92,7	437,4	453,2	349,8	372,8	222,1	0,19	84,34	85,61	84,53	0,19	85,55	85,84	83,04
342,0	524,0	1,5	0,2	5,8	207,8	77,0	92,1	437,4	452,5	349,6	372,2	222,0	0,19	84,10	85,55	84,46	0,19	85,37	85,78	83,06
343,0	525,0	1,5	0,2	5,8	207,7	77,0	91,6	437,3	451,7	349,4	372,6	221,9	0,19	83,91	85,47	84,39	0,19	85,24	85,76	83,08
344,0	526,0	1,5	0,2	5,8	207,8	77,0	91,1	437,2	451,0	349,3	372,3	221,9	0,19	83,71	85,37	84,31	0,19	85,08	85,69	83,11
345,0	527,0	1,5	0,2	5,9	208,0	77,1	90,8	437,2	450,2	349,1	372,1	221,6	0,19	83,54	85,31	84,25	0,19	84,93	85,63	83,08
346,0	528,0	1,4	0,2	5,9	208,1	76,8	90,5	437,0	449,3	348,8	371,8	221,5	0,19	83,36	85,21	84,19	0,19	84,77	85,58	83,10
347,0	529,0	1,5	0,2	5,9	208,1	77,0	90,3	436,7	448,5	348,8	371,8	221,3	0,19	83,24	85,14	84,13	0,19	84,63	85,52	83,09
348,0	530,0	1,4	0,2	5,9	208,1	76,5	89,9	436,5	447,7	348,4	371,5	221,3	0,19	83,10	85,05	84,05	0,19	84,50	85,46	83,09
349,0	531,0	1,4	0,2	5,9	208,4	76,7	89,7	436,4	447,0	348,2	371,5	221,3	0,19	82,98	84,97	83,97	0,19	84,36	85,42	83,06
350,0	532,0	1,4	0,2	5,8	208,0	76,8	90,8	436,3	446,1	348,2	371,3	221,0	0,19	82,92	84,93	83,91	0,19	84,30	85,35	83,03
351,0	533,0	1,4	0,2	5,9	207,7	76,4	92,3	436,1	445,5	348,0	371,0	221,3	0,19	83,04	84,92	83,92	0,19	84,33	85,34	83,00
352,0	534,0	1,4	0,2	5,9	207,1	76,7	93,8	436,0	444,8	347,9	370,9	221,3	0,19	83,24	84,97	83,96	0,19	84,44	85,36	83,00
353,0	535,0	1,4	0,2	5,9	206,9	77,0	95,4	436,1	444,0	347,6	371,2	221,1	0,19	83,42	85,01	84,03	0,19	84,55	85,41	83,01
354,0	536,0	1,4	0,2	5,9	206,6	76,9	96,5	436,2	443,3	347,7	371,2	221,2	0,19	83,60	85,07	84,11	0,19	84,68	85,44	83,03
355,0	537,0	1,4	0,2	5,9	206,6	77,1	98,1	436,2	442,5	347,6	370,9	221,0	0,19	83,87	85,17	84,25	0,19	84,83	85,52	83,04
356,0	538,0	1,4	0,2	5,9	206,3	77,0	98,8	436,1	441,9	347,4	371,4	221,0	0,19	84,08	85,27	84,35	0,19	84,98	85,59	83,05
357,0	539,0	1,3	0,2	5,8	206,0	77,0	99,6	435,9	441,3	347,3	371,2	220,9	0,19	84,30	85,37	84,49	0,19	85,18	85,67	83,09
358,0	540,0	1,3	0,2	5,8	206,1	77,2	100,5	435,7	440,7	347,5	370,9	220,9	0,19	84,50	85,49	84,61	0,19	85,34	85,78	83,13
359,0	541,0	1,3	0,2	5,8	205,7	77,0	101,1	435,5	440,1	347,3	371,0	220,9	0,19	84,72	85,61	84,72	0,19	85,54	85,85	83,17
360,0	542,0	1,3	0,2	5,9	205,5	76,8	99,1	435,3	439,4	347,3	371,1	220,8	0,19	84,90	85,71	84,80	0,19	85,69	85,96	83,20
361,0	543,0	1,3	0,2	5,9	205,6	77,1	97,0	435,1	438,9	347,2	370,8	220,6	0,19	84,94	85,75	84,80	0,19	85,76	86,01	83,24
362,0	544,0	1,3	0,2	5,9	206,1	76,5	95,2	434,8	438,3	347,0	370,9	220,6	0,19	84,87	85,76	84,73	0,19	85,76	86,03	83,25
363,0	545,0	1,3	0,2	5,9	206,3	77,0	94,1	434,7	437,7	346,9	370,9	220,5	0,19	84,71	85,74	84,69	0,19	85,71	86,01	83,24
364,0	546,0	1,3	0,2	5,7	206,6	77,1	93,2	434,6	437,1	346,9	370,7	220,2	0,19	84,52	85,71	84,63	0,19	85,62	85,99	83,27
365,0	547,0	1,2	0,2	5,7	207,0	77,1	92,5	434,4	436,5	346,6	370,5	220,2	0,19	84,32	85,66	84,55	0,19	85,49	85,97	83,26
366,0	548,0	1,2	0,2	5,7	206,9	77,2	92,0	434,3	436,0	346,5	370,3	220,0	0,19	84,09	85,58	84,49	0,19	85,33	85,92	83,28
367,0	549,0	1,2	0,2	5,6	207,2	77,2	91,5	434,1	435,4	346,3	370,4	219,7	0,19	83,89	85,52	84,44	0,19	85,21	85,85	83,28
368,0	550,0	1,2	0,2	5,6	207,1	77,1	91,1	433,8	434,8	346,1	370,3	219,8	0,19	83,73	85,46	84,37	0,19	85,06	85,82	83,30
369,0	551,0	1,2	0,2	5,7	206,8	77,1	90,7	433,4	434,3	346,0	369,9	219,7	0,19	83,54	85,38	84,29	0,19	84,92	85,76	83,28
370,0	552,0	1,2	0,2	5,7	207,1	77,2	90,5	433,0	433,8	345,8	369,9	219,6	0,19	83,39	85,30	84,23	0,19	84,77	85,71	83,27
371,0	553,0	1,1	0,2	5,7	206,9	77,0	90,2	432,6	433,2	345,8	370,0	219,6	0,19	83,25	85,23	84,15	0,19	84,65	85,64	83,23
372,0	554,0	1,1	0,2	5,6	206,6	77,1	90,0	432,4	432,8	345,6	369,7	219,3	0,19	83,14	85,18	84,08	0,19	84,52	85,58	83,20
373,0	555,0	1,1	0,2	5,7	206,6	77,1	89,8	432,0	432,2	345,5	369,8	219,2	0,19	83,02	85,08	84,00	0,19	84,40	85,54	83,20
374,0	556,0	1,1	0,2	5,6	206,6	76,9	89,6	431,8	431,7	345,3	369,8	219,3	0,19	82,91	85,01	83,92	0,19	84,31	85,48	83,18
375,0	557,0	1,1	0,2	5,7	206,6	77,2	90,2	431,5	431,2	345,2	369,2	219,0	0,19	82,86	84,97	83,88	0,19	84,22	85,44	83,15
376,0	558,0	1,1	0,2	5,6	206,4	76,5	91,9	431,1	430,8	344,9	369,5	219,3	0,19	83,00	84,95	83,85	0,19	84,25	85,41	83,12
377,0	559,0	1,1	0,2	5,7	205,9	76,5	93,2	430,9	430,4	344,9	369,0	219,3	0,19	83,20	84,98	83,89	0,19	84,37	85,43	83,09
378,0	560,0	1,1	0,2	5,7	205,2	77,1	94,6	430,7	429,9	344,7	369,0	219,2	0,19	83,37	85,02	83,95	0,19	84,47	85,47	83,10
379,0	561,0	1,0	0,2	5,8	204,9	77,1	95,8	430,5	429,5	344,7	368,8	219,2	0,19	83,58	85,09	84,05	0,19	84,61	85,51	83,10
380,0	562,0	1,1	0,2	5,8	204,5	76,9	97,2	430,3	429,1	344,7	368,9	219,2	0,19	83,80	85,16	84,16	0,19	84,76	85,58	83,10
381,0	563,0	1,0	0,2	5,8	204,5	77,0	98,4	430,2	428,6	344,5	368,6	219,2	0,19	84,01	85,26	84,28	0,19	84,91	85,65	83,13
382,0	564,0	1,0	0,2	5,8	204,5	77,2	99,1	430,0	428,2	344,5	369,0	219,2	0,19	84,21	85,37	84,41	0,19	85,07	85,73	83,15
383,0	565,0	1,0	0,2	5,8	204,0	77,2	99,7	429,9	427,9	344,3	368,8	219,1	0,19	84,42	85,47	84,53	0,19	85,26	85,81	83,17
384,0	566,0	1,0	0,2	5,8	203,9	77,0	98,2	429,7	427,5	344,1	368,6	219,0	0,19	84,59	85,58	84,60	0,19	85,40	85,88	83,20
385,0	567,0	1,0	0,2	5,8	204,2	77,3	96,4	429,5	427,1	344,2	368,4	218,9	0,19	84,67	85,61	84,60	0,19	85,49	85,93	83,21
386,0	568,0	1,0	0,2	5,8	204,5	76,8	94,7	429,4	426,7	344,0	368,3	218,9	0,19	84,62	85,64	84,55	0,19	85,48	85,95	83,22
387,0	569,0	0,9	0,2	5,8	204,7	77,1	93,6	429,2	426,4	343,8	368,1	218,8	0,19	84,47	85,61	84,51	0,19	85,46	85,94	83,24
388,0	570,0	1,0	0,2	5,7	205,3	77,2	92,8	429,2	426,3	343,7	367,9	218,6	0,19	84,28	85,57	84,44	0,19	85,35	85,92	83,24
389,0	571,0	0,9	0,2	5,7	205,5	77,2	92,1	428,8	425,7	343,5	367,8	218,5	0,19	84,08	85,52	84,37	0,19	85,24	85,89	83,25
390,0	572,0	0,9	0,2	5,7	205,6	77,2	91,6	428,7	425,3	343,4	367,4	218,4	0,19	83,90	85,45	84,32	0,19	85,12	85,87	83,27
391,0	573,0	0,9	0,2	5,7	205,8	77,3	91,1	428,6	425,0	343,3	367,3	218,2	0,19	83,71	85,39	84,28	0,19	85,00	85,82	83,25
392,0	574,0	0,9	0,2	5,7	206,0	77,1	90,6	428,5	424,6	343,2	367,3	218,2	0,19	83,55	85,32	84,18	0,19	84,87	85,75	83,24
393,0	575,0	0,9	0,2	5,7	205,8	77,3	90,4	428,4	424,4	342,9	367,2	217,9	0,19	83,39	85,26	84,14	0,19	84,74	85,71	83,22
394,0	576,0	0,9	0,2	5,7	206,0	77,2	90,1	428,2	424,1	342,7	366,7	217,8	0,19	83,25	85,18	84,04	0,19	84,62	85,65	83,18
395,0	577,0	0,9	0,2	5,7	206,2	77,2	89,8	428,1	423,8	342,4	366,7	217,7	0,19	83,10	85,10	83,96	0,19	84,47	85,59	83,14
396,0	578,0	0,9	0,2	5,7	205,7	76,7	89,5	427,7	423,5	342,3	366,7	217,8	0,19	82,97	85,04	83,87	0,19	84,36	85,54	83,11
397,0	579,0	0,9	0,2	5,5	205,6	77,0	89,4	427,3	423,2	342,0	366,6	217,7	0,19	82,87	84,99	83,81	0,19	84,27	85,49	83,08
398,0	580,0	0,8	0,2	5,5	205,4	77,2	89,4	426,9	423,1	342,0	366,2	217,6	0,19	82,75	84,93	83,72	0,19	84,14	85,45	83,06
399,0	581,0	0,8	0,2	5,4	205,6	77,1	89,5	426,5	422,8	341,8	366,4	217,5	0,19	82,69	84,87	83,64	0,19	84,06	85,	

426,0	608,0	0,5	0,2	4,8	197,3	76,9	94,0	408,3	414,1	334,5	355,4	215,5	0,19	83,03	84,77	83,59	0,19	84,10	85,30	82,85
427,0	609,0	0,5	0,2	4,8	196,8	76,6	95,5	407,7	413,7	334,2	355,0	215,4	0,19	83,23	84,83	83,71	0,19	84,21	85,32	82,86
428,0	610,0	0,5	0,2	4,9	196,2	76,5	97,1	407,3	413,2	333,8	354,7	215,3	0,19	83,47	84,92	83,77	0,19	84,38	85,39	82,84
429,0	611,0	0,5	0,2	4,9	196,0	76,9	98,2	406,8	412,8	333,4	354,3	215,3	0,19	83,68	85,00	83,91	0,19	84,54	85,46	82,84
430,0	612,0	0,5	0,2	4,9	195,7	77,1	99,6	406,4	412,4	332,9	353,6	215,1	0,19	83,91	85,08	84,05	0,19	84,69	85,54	82,86
431,0	613,0	0,5	0,2	4,9	195,4	77,2	100,0	405,9	411,9	332,7	353,0	215,0	0,19	84,09	85,19	84,16	0,19	84,88	85,62	82,90
432,0	614,0	0,5	0,2	4,9	195,2	77,2	100,0	405,4	411,5	332,2	352,3	214,8	0,19	84,28	85,30	84,32	0,19	85,04	85,68	82,91
433,0	615,0	0,4	0,2	4,9	194,8	77,2	97,5	404,9	411,0	331,6	351,9	214,7	0,19	84,41	85,35	84,34	0,19	85,17	85,76	82,95
434,0	616,0	0,4	0,2	4,9	195,3	76,8	95,6	404,3	410,6	331,5	351,6	214,5	0,19	84,47	85,39	84,30	0,19	85,21	85,78	82,99
435,0	617,0	0,4	0,2	4,9	195,6	77,1	94,0	404,0	410,2	330,7	351,1	214,3	0,19	84,38	85,40	84,26	0,19	85,22	85,80	83,00
436,0	618,0	0,4	0,2	4,8	195,5	77,3	93,0	403,7	409,6	330,3	350,6	214,0	0,19	84,21	85,38	84,20	0,19	85,14	85,79	83,00
437,0	619,0	0,4	0,2	4,8	195,7	77,2	92,1	403,2	409,3	329,9	350,1	213,8	0,19	84,03	85,34	84,15	0,19	85,05	85,76	83,01
438,0	620,0	0,4	0,2	4,8	195,5	77,0	91,4	402,6	408,7	329,4	349,7	213,7	0,19	83,86	85,32	84,10	0,19	84,96	85,73	83,02
439,0	621,0	0,4	0,2	4,9	195,4	76,7	90,9	402,0	408,3	329,1	349,2	213,6	0,19	83,69	85,24	84,03	0,19	84,84	85,71	83,00
440,0	622,0	0,4	0,2	4,9	195,3	77,1	90,3	401,6	407,8	328,5	348,7	213,3	0,19	83,52	85,19	83,94	0,19	84,73	85,66	82,98
441,0	623,0	0,4	0,2	4,9	195,3	77,0	89,9	401,2	407,4	328,1	348,1	213,0	0,19	83,35	85,14	83,87	0,19	84,60	85,62	82,96
442,0	624,0	0,3	0,2	4,8	195,5	76,9	89,7	400,7	406,9	327,6	347,7	212,7	0,19	83,24	85,09	83,83	0,19	84,50	85,57	82,95
443,0	625,0	0,3	0,2	4,8	195,3	76,9	89,4	400,4	406,4	327,2	347,2	212,3	0,19	83,10	85,02	83,73	0,19	84,40	85,50	82,92
444,0	626,0	0,4	0,2	4,8	194,9	77,0	89,1	400,0	406,0	326,7	346,8	212,2	0,19	82,96	84,95	83,71	0,19	84,30	85,45	82,89
445,0	627,0	0,3	0,2	4,8	194,6	77,0	89,1	399,5	405,6	326,3	346,2	212,0	0,19	82,87	84,90	83,61	0,19	84,22	85,41	82,89
446,0	628,0	0,3	0,2	4,8	194,7	77,0	88,8	399,1	405,2	326,0	345,8	211,6	0,19	82,76	84,82	83,55	0,19	84,10	85,33	82,86
447,0	629,0	0,3	0,2	4,8	194,4	76,8	88,7	398,7	404,8	325,5	345,5	211,4	0,19	82,67	84,75	83,46	0,19	84,01	85,29	82,83
448,0	630,0	0,3	0,2	4,8	194,5	77,0	89,6	398,4	404,4	325,1	344,7	211,0	0,19	82,63	84,71	83,41	0,19	83,96	85,24	82,77
449,0	631,0	0,3	0,2	4,8	194,1	76,5	91,5	398,0	404,0	324,7	344,6	211,0	0,19	82,78	84,70	83,43	0,19	83,98	85,20	82,74
450,0	632,0	0,3	0,2	4,8	193,8	76,7	92,9	397,6	403,7	324,5	343,9	210,9	0,19	83,03	84,71	83,46	0,19	84,05	85,24	82,72
451,0	633,0	0,2	0,2	4,8	193,0	77,0	94,6	397,4	403,3	324,1	343,7	210,7	0,19	83,22	84,76	83,54	0,19	84,14	85,26	82,71
452,0	634,0	0,2	0,2	4,8	192,6	76,9	96,3	397,0	403,0	323,9	343,5	210,6	0,19	83,44	84,82	83,65	0,19	84,28	85,32	82,73
453,0	635,0	0,2	0,2	4,9	192,1	77,2	97,9	396,7	402,7	323,3	343,1	210,4	0,19	83,66	84,91	83,79	0,19	84,45	85,35	82,74
454,0	636,0	0,3	0,2	4,9	191,8	77,2	98,9	396,4	402,3	323,2	342,5	210,3	0,19	83,88	84,98	83,93	0,19	84,60	85,44	82,76
455,0	637,0	0,2	0,2	4,9	191,5	77,1	100,0	396,0	402,0	323,1	342,5	210,2	0,19	84,09	85,09	84,10	0,19	84,78	85,50	82,82
456,0	638,0	0,2	0,2	4,9	191,4	77,3	100,3	395,8	401,7	322,6	342,1	210,0	0,19	84,34	85,23	84,23	0,19	84,97	85,60	82,84
457,0	639,0	0,2	0,2	4,9	191,3	77,2	98,3	395,4	401,4	322,4	341,6	209,8	0,19	84,53	85,31	84,31	0,19	85,12	85,69	82,88
458,0	640,0	0,2	0,2	4,8	191,6	77,3	96,2	395,2	401,1	322,1	341,3	209,7	0,19	84,61	85,36	84,31	0,19	85,20	85,75	82,91
459,0	641,0	0,2	0,2	4,8	191,7	76,8	94,4	394,8	400,7	321,5	341,1	209,5	0,19	84,54	85,37	84,25	0,19	85,21	85,75	82,92
460,0	642,0	0,2	0,2	4,7	191,8	77,3	93,1	394,5	400,5	321,3	340,4	209,3	0,19	84,40	85,37	84,23	0,19	85,14	85,75	82,94
461,0	643,0	0,1	0,2	4,7	191,8	77,3	92,1	394,1	400,1	321,0	340,2	208,9	0,19	84,23	85,33	84,17	0,19	85,06	85,74	82,95
462,0	644,0	0,2	0,2	4,7	191,9	77,2	91,5	393,7	399,8	320,6	339,8	208,6	0,19	84,06	85,29	84,13	0,19	84,98	85,71	82,96
463,0	645,0	0,1	0,2	4,7	192,0	77,2	90,9	393,2	399,5	320,4	339,5	208,4	0,19	83,93	85,24	84,06	0,19	84,90	85,67	82,98
464,0	646,0	0,1	0,2	4,7	191,9	77,1	90,4	392,8	399,2	320,0	339,3	208,3	0,19	83,74	85,21	83,98	0,19	84,77	85,63	82,98
465,0	647,0	0,1	0,2	4,6	191,9	77,0	90,0	392,3	398,8	319,6	338,8	208,0	0,19	83,61	85,16	83,93	0,19	84,69	85,59	82,97
466,0	648,0	0,1	0,2	4,6	191,9	76,8	89,6	391,9	398,5	319,3	338,5	208,0	0,19	83,49	85,09	83,88	0,19	84,60	85,56	82,96
467,0	649,0	0,1	0,2	4,6	191,8	76,9	89,4	391,5	398,3	319,1	337,6	207,9	0,19	83,38	85,03	83,80	0,19	84,47	85,50	82,93
468,0	650,0	0,1	0,2	4,7	192,0	76,9	89,2	391,2	397,9	318,7	337,6	207,8	0,19	83,28	84,96	83,72	0,19	84,37	85,44	82,88
469,0	651,0	0,1	0,2	4,7	191,7	76,9	88,8	390,9	397,7	318,4	337,1	207,9	0,19	83,14	84,91	83,63	0,19	84,24	85,39	82,88
470,0	652,0	0,1	0,2	4,7	191,5	76,9	88,8	390,6	397,5	318,1	336,7	207,7	0,19	83,00	84,85	83,53	0,19	84,11	85,36	82,83
471,0	653,0	0,1	0,2	4,7	191,6	76,9	88,6	390,2	397,2	317,7	336,5	207,6	0,19	82,92	84,76	83,47	0,19	84,02	85,29	82,78
472,0	654,0	0,0	0,2	4,5	191,3	76,9	88,4	389,8	396,8	317,3	335,8	207,4	0,19	82,82	84,71	83,40	0,19	83,98	85,24	82,75



Manufacturer: WOLFSTEEL  
 Model: EPI3

Run: 1  
 Project #: PI-20190  
 Test Duration: 472 min

	HHV	LHV
Eff	66,81%	71,89%
Comb Eff	99,06%	99,06%
HT Eff	67,45%	72,57%
Output	50 482	kJ/h
Burn Rate	3,74	kg/h
Grams CO	103	g
Input	75 558	kJ/h
MC wet	16,94	

Note: In the "Input data", "Calc. % O<sub>2</sub>", "Fuel Properties", and "Mass Balance" columns, [e], [d], [g], [a], [b], [c], [h], [u], [w], [j], and [k] refer to their respective variables in Clauses 13.7.3

Ultimate CO<sub>2</sub>  
 CO<sub>2-ut</sub> 19,86  
 F<sub>o</sub>  
 1,050

	Air Fuel Ratio (A/F)	
Overall Heating Efficiency:	66,81%	Dry Molecular Weight (M <sub>d</sub> ) 29,98
Combustion Efficiency:	99,06%	Dry Moles Exhaust Gas (N <sub>g</sub> ): 379,20
Heat Transfer Efficiency:	67,45%	Air Fuel Ratio (A/F) 10,86

Heat Output:	47 887 Btu/h	50 482 kJ/h
Heat Input:	71 675 Btu/h	75 558 kJ/h
Burn Duration:	1,62 h	
Burn Rate:	8,24 lb/h	3,739 kg/h
Stack Temp:	639,2 Deg. F	337,3 Deg. C

Manufacturer: WOLFSTEEL  
 Model: EPI3

Run: 1  
 Project #: PI-20190  
 Test Duration: 472 min

	HHV	LHV
Eff	73,72%	79,32%
Comb Eff	95,02%	95,02%
HT Eff	77,58%	83,47%
Output	15 277	kJ/h
Burn Rate	1,03	kg/h
Grams CO	583	g
Input	20 724	kJ/h
MC wet	16,98	

Note: In the "Input data", "Calc. % O<sub>2</sub>", "Fuel Properties", and "Mass Balance" columns, [e], [d], [g], [a], [b], [c], [h], [u], [w], [j], and [k] refer to their respective variables in Clauses 13.7.3

Ultimate CO<sub>2</sub>  
 CO<sub>2-ut</sub> 19,86  
 F<sub>o</sub>  
 1,050

	Air Fuel Ratio (A/F)
Overall Heating Efficiency:	73,72%
Combustion Efficiency:	95,02%
Heat Transfer Efficiency:	77,58%

Dry Molecular Weight (M <sub>d</sub> )	29,76
Dry Moles Exhaust Gas (N <sub>g</sub> ):	429,11
Air Fuel Ratio (A/F)	12,26

Heat Output:	14 492 Btu/h	15 277 kJ/h
Heat Input:	19 659 Btu/h	20 724 kJ/h
Burn Duration:	7,87 h	
Burn Rate:	2,26 lb/h	1,026 kg/h
Stack Temp:	278,1 Deg. F	136,7 Deg. C

Date: 2019-04-01 Manufacturer: WOLFSTEEL Model: EPI-3  
 Project #: PF-20190 Run: 1 Tech: SB Reviewer: SP

- KINDLING 8.5 lbs, started fire (HALF/HALF MIN).
- closed door immediately
- AT 2.7 lbs, inserted Hi load, closed door immediately
- after 10 min, started fan @ MED SPEED.
- AT 4.3 lbs stop pump and fan
- AT 3.8 lbs inserted low load, closed door immediately
- AT 13 min, closed air inlet by 1/2.
- AT 14 min " " " " " " ↓ 1/4.
- AT 15 min closed air inlet to final position (gap 1 7/8)
- NO FAN!

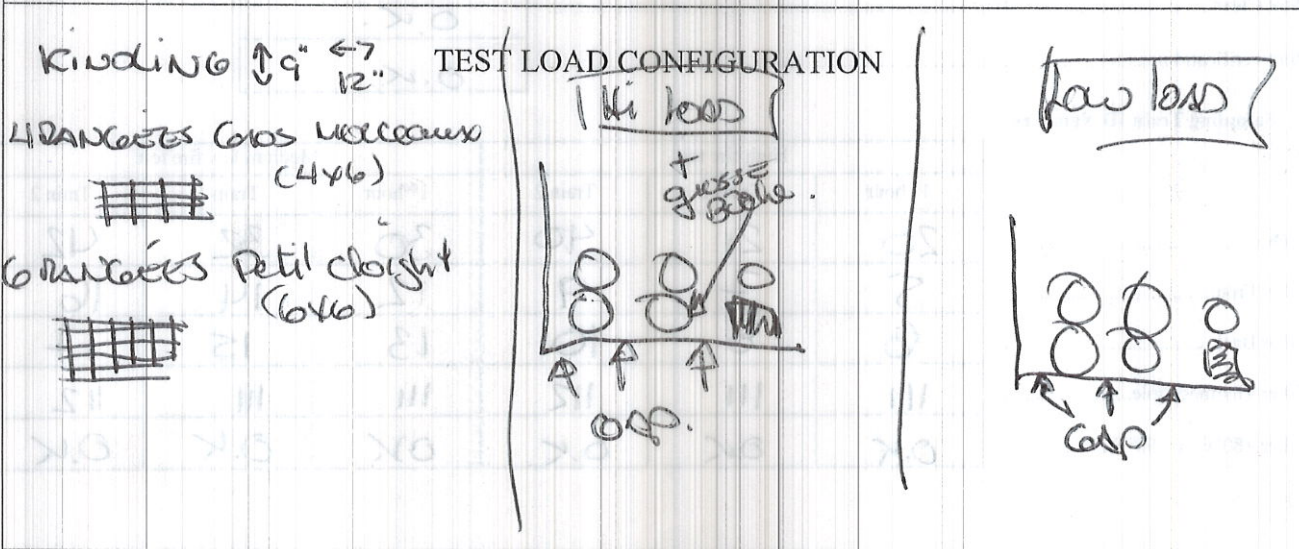

# PRE / POST CHECKS

Date: 2019-04-01 Manufacturer: WOLF STEEL Model: EDI-3  
 Project #: PI-20190 Run: 1 Tech: S.B Reviewer: NP

Moisture Meter Calibration Check:

Equipment #	Time	12%	22%
EM-191	7:00	OK	OK

### Facility Conditions:

Air Velocity from less than 2 feet .....  
 Smoke Capture Check (Tunnel velocity).....  
 Picture.....

Pre-Test	Post-Test
0 (max50 Fpm)	0 (max50 Fpm)
O.K.	NA
4 sides O.K.	OK

### Wood Heater Conditions:

Date Wood Heater Stack Cleaned.....  
 Date Dilution Tunnel Cleaned.....  
 Induced Draft Check (max 0.005 H2O).....  
 Traverse before ignition.....

2019-04-01
2019-04-01
O.K.
O.K.

### Temperature System:

Ambient (65°-90°F).....

O.K.	°F
------	----

### Proportional Checks:

Thermocouple check.....  
 Pitot Clean.....  
 Pitot verification.....

O.K.
O.K.
O.K.

### Sampling Train ID Numbers:

	High fire test			Medium low fire test		
	1 <sup>st</sup> hour	Train 1	Train 2	1 <sup>st</sup> hour	Train 1	Train 2
Probe.....	20	21	40	30	32	42
Filter Front.....	5	7	9	12	14	16
Filter Back.....	6	8	10	13	15	17
Filter Thermocouple.....	111	111	112	111	111	112
Filter (80°F ≥ <90°F).....	O.K.	O.K.	O.K.	O.K.	O.K.	O.K.

**SAMPLING EQUIPMENT CHECK OUT**

 Date: 2019-04-01 Manufacturer: WOLF STEEL Model: EDI-3  
 Project #: PT-20190 Run: 1 Tech: SB Reviewer: TP
**Leakage Checks Tunnel Samplers**

High fire test	System 1 <sup>st</sup> hour		System 1		System 2	
	Pre-Test ASTM (-15) CSA B415 (-5)	Post-Test (max test)	Pre-Test ASTM (-15) CSA B415 (-5)	Post-Test (Max test)	Pre-Test ASTM (-15) CSA B415 (-5)	Post-Test (Max test)
Unplugged Flow Rate = 25cfm						
Vacuum (inches Hg.)	-15	-15	-15	-15	-15	-15
Final 1minute DGM (Liter)	882637.85	883360.05	882638.09	883360.18	832513.13	833221.68
Initial 1minute DGM (Liter)	882637.75	883359.95	882638.06	883360.10	832513.13	833221.66
Change © (Liter)	0.1	0.1	0.03	0.08	∅	0.02
Allowable leakage .04 x Sample rate or 0.28Lpm CSA B415 (0.56)						
Check OK	O.K	O.K	O.K	O.K	O.K	O.K

Low medium fire test	System 1 <sup>st</sup> hour		System 1		System 2	
	Pre-Test ASTM (-15) CSA B415 (-5)	Post-Test (max test)	Pre-Test ASTM (-15) CSA B415 (-5)	Post-Test (Max test)	Pre-Test ASTM (-15) CSA B415 (-5)	Post-Test (Max test)
Unplugged Flow Rate = 25cfm						
Vacuum (inches Hg.)	-15	-15	-15	-15	-15	-15
Final 1minute DGM (Liter)	883360.99	886066.29	883361.09	886066.64	833222.95	835866.78
Initial 1minute DGM (Liter)	883360.95	886066.27	883361.06	886066.61	833222.94	835866.74
Change © (Liter)	0.04	0.02	0.03	0.03	0.01	0.04
Allowable leakage .04 x Sample rate or 0.28Lpm CSA B415 (0.56)						
Check OK	O.K	O.K	O.K	O.K	O.K	O.K



## SAMPLING EQUIPMENT CHECK OUT

Date: 2019-04-01 Manufacturer: WOLF STEEL Model: EPI-3  
 Project #: PI-20190 Run: 1 Tech: SB Reviewer: NS

### Leakage Checks Flue Gas Sampler

Plugged Probe	Pre-Test	Post Test
Vacuum (inches Hg.)	-5	-5
Rotameter Reading (mml/min.)	0	0
Flow Rate (lpm)	1.5	1.5
Allowable (.02 x Sample Rate)	30	30
Check OK	O.K.	O.K.

### Leakage Checks Pitot

Plugged Probe	Pre Test	Pre Test	Post Test	Post Test
	3 H <sub>2</sub> O static	0.4-0.5 H <sub>2</sub> O velocity	3 H <sub>2</sub> O Static	0.4-0.5 H <sub>2</sub> O velocity
Vacuum (inches Hg.)	3	0.5	3	0.4739
Check OK (no change after 15 sec.)	O.K.	O.K.	O.K.	O.K.

**PRE-TEST SCALE AUDIT**

 Date: 2019-04-01 Manufacturer: WOLFSTEEL Model: EPI-3  
 Project #: PI-20190 Run: 1 Tech: SB Reviewer: [Signature]

Scale Type	Audit		Measured Weight
	Equipment #	Weight	
Platform	EM-090	4.4 lbs, Class F	4.4 lbs
Wood	EM-090	4.4 lbs, Class F	4.4 lbs
Analytical	EM-128	100 mg, Class S	100 mg
Analytical	EM-129	200 g, Class S	200 g

**LIMITS OF WEIGHT RANGES**

**ANALYTICAL SCALE:** ..... 50%-150% of dry filter weight,  $\pm 0.1$  mg  
**PLATFORM SCALE:** ..... 20%-80% of ideal test load weight,  $\pm 0.1$  lbs or 1%  
**WOOD SCALE:** ..... 20%-80% of ideal test load weight,  $\pm 0.01$  lbs or 1%

Date: 2019.04.01 Manufacturer: WORSTEEL Model: EPI-3  
 Project #: P.20190 Run: 1 Tech: MR Reviewer: DP
**FOR TUNNELS < 12 in**

 Barometric pressure ( $P_{bar}$ ) 1018 (KPa.) Static pressure ( $P_q$ ) 0.17 (inches w.c.)  
 Inside diameter: Port A \_\_\_\_\_ Port B \_\_\_\_\_  
 Tunnel cross sectional area: .1963Ft<sup>2</sup>  
 Pitot tube type: Standard

Traverse Point	Position (inches)			Velocity Head $\Delta_p$ (inches H <sub>2</sub> O)	Tunnel Temperature (°F)
	6 po	7 po	8 po		
A- Centroid	3.00	3.50	4	0058	7684
B - Centroid	3.00	3.50	4	0057	7563
A-1	0.40	0.50	0.50	0058	7671
A-2	1.50	1.75	2	0064	7655
A-3	4.50	5.25	6	0069	7617
A-4	5.60	6.5	7.5	0063	7596
B-1	0.40	0.50	0.50	0050	7509
B-2	1.50	1.75	2	0048	7497
B-3	4.50	5.25	6	0048	7458
B-4	5.60	6.5	7.5	0050	7403
AVERAGE					

$$v_s = K_p C_p (\sqrt{\Delta p})_{avg} \sqrt{\frac{(T_s)_{avg}}{P_s M_s}}$$

Where,

 $C_p$  = pitot tube coefficient, dimension less = 0.99 for standard pitot.

 $\Delta_p$  = manometer reading (inches H<sub>2</sub>O)

 $T_s$  = average absolute dilution tunnel temperature (°F + 460)

 $P_s$  = absolute dilution tunnel gas pressure or  $P_{bar} + P_{qg}$ 
 $P_q$  = static pressure in. H<sub>2</sub>O  
 { 13.6 }

 $M_s$  = 28.56, wet molecular weight of stack gas (alternatively, it may be measured)

 $K_p$  = 85.49 pitot tube constant, (conversion factor for English units)

 $\Delta_p$  avg. = average of the square roots of the velocity heads ( $\Delta_p$ ) measured at each traverse point.



Date: 2019-03-01 Manufacturer: Wolf Steel Model: EPI-3  
 Project #: PI 20190 Run: 1 Tech: MM Reviewer: DP

## Pre-Test (Adjust and Record)

	ZERO		SPAN		CAL. (Record Only)	
	Actual	Should Be	Actual	Should Be	Actual	Should Be
CO	0	0	2,964	3000	1,006	1,000
Tolerance CO		+/- 0.02		+/- 0.15		+/- 0.05
CO <sub>2</sub>	0	0	17,910	18,000	9,77	10,000
Tolerance CO <sub>2</sub>		+/- 0.02		+/- 0.5		+/- 0.5
O <sub>2</sub> informative CSA B415 calculated value	na	na	na	na	na	na
	Actual	Should Be	Actual	Should Be	Actual	Should Be

## Post Test (Record Only)

	Zero	Span	Cal.	Zero Drift	Limit	Span Drift	Limit	Cal. Drift	Limit	OK?	Not OK*
CO	0	2979	1,006	0	0.02	0.015	0.15	0	0.05	OK	
CO <sub>2</sub>	0	17,93	9,76	0	0.02	0.02	0.5	0.01	0.5	OK	

**TEST DATA LOG**

Date: 2019-04-01 Manufacturer: WOLFSTEEL Model: EPI-3  
 Project #: PI-20190 Run: 1 Tech: SS. Reviewer: RS

**RAW DRY GAS METER READINGS**

		System 1	System 2	Blank
High fire test	Final (Liter)	883 358.85	833 220.65	826.48
	Initial (Liter)	882 638.25	832 513.66	704.70
Low medium fire test	Final (Liter)	886 065.69	835 865.79	944.90
	Initial (Liter)	883 361.44	833 223.33	826.48

**AMBIENT CONDITIONS**

	Before	After
Barometer (kPa):	101.8	102.1
Dry Bulb (F):	70.16	68.5
Humidity (%):	20.6	22.6

## FUEL DATA

Date: 2019-04-01 Manufacturer: WOLF STEEL Model: EPI-3  
 Project #: PI-20190 Run: 1 Tech: SB Reviewer: N

### FUEL DESCRIPTION:

Type of wood:

### KINDLING AND START-UP LOAD

Piece Size			Weight		Meter Moisture Content (% dry)			
X	X	in.	3.5	lbs.	9		9	9
X	X	in.	5	lbs.	20		20	20
X	X	in.		lbs.				
X	X	in.		lbs.				
X	X	in.		lbs.				
X	X	in.		lbs.				
X	X	in.		lbs.				
X	X	in.		lbs.				
X	X	in.		lbs.				

### HIGHFIRE TEST LOAD

Piece Size		Weight		Meter Moisture Content (% dry)			
3.25	3 x 16 in.	3.746	lbs.	18.6		18.9	21.7
3.25	3.5 x 16 in.	3.576	lbs.	17.6		25.3	23.4
2.75	x 3.25 x 16 in.	3.402	lbs.	20.2		18.3	21.4
3.75	x 3.75 x 16 in.	5.166	lbs.	19.6		20.8	18.4
2.5	x 2.25 x in.	2.064	lbs.	22.2		18.9	19.8
X	X in.		lbs.				
X	X in.		lbs.				
X	X in.		lbs.				
X	X in.		lbs.				

### FUEL DATA

Date: 2019-04-01 Manufacturer: WOLF STEEL Model: EPI-3  
 Project #: PI-20190 Run: 1 Tech: S.B. Reviewer: SP

#### FUEL DESCRIPTION:

Type of wood:

#### LOW OR MEDIUM TEST LOAD

Piece Size	Weight	Meter Moisture Content (% dry)				
4 x 3 x 16 in.	4,362 lbs.	18.1		18.2		26.2
3.75 x 2.75 x 16 in.	4,388 lbs.	19.3		26.2		18.3
3.5 x 3.75 x 16 in.	4,580 lbs.	18.3		18.9		18.4
2.75 x 2.75 x 16 in.	2,768 lbs.	20.2		22.3		18.6
3.5 x 4 x 16 in.	5,320 lbs.	25.2		18.8		19.7
x x in.	lbs.					
x x in.	lbs.					
x x in.	lbs.					
x x in.	lbs.					
x x in.	lbs.					
x x in.	lbs.					
x x in.	lbs.					
x x in.	lbs.					
x x in.	lbs.					

# DILUTION TUNNEL PARTICULATE SAMPLER DATA

Date: 2019.03.29 Manufacturer: Wolf Steel Model: LPJ-3  
 Project #: PT 20190 Run: 1 Tech: MM Reviewer: SP

Low pr

## HIGH-PRESSURE TEST FILTERS

### SYSTEM 1 - 1<sup>st</sup> hour

Pre-test Weight Record		Probe & Housing Number	Front Filter Number	Back Filter Number	gaskets	Probe & Housing Number	Front Filter Number	Back Filter Number	gaskets	Blank
Date	Time	30	12	13	9	32	14	15	42	19
2019.03.29	10:00	110 2223	00880	00867	34 9900	110 1775	00886	00829	35 5181	00865
2019.04.01	7:00	110 2223	00880	00867	34 9900	110 1775	00886	0029	35 5181	00865

### SYSTEM 1 - 1<sup>st</sup> hour

Post-test Weight Record		Probe & Housing Number	Front Filter Number	Back Filter Number	gaskets	Probe & Housing Number	Front Filter Number	Back Filter Number	gaskets	Blank
Date	Time	30	12	13	9	32	14	15	42	19
2019.04.02	8:00	110 2240 <del>110 2223</del>	00887	00848	34 9923	110 1775	00892	00810	35 5213	00867
2019.04.10	15:00	110 2240	00885	00848	34 9920	110 1775	00892	00810	35 5208	00867
2019.04.15	8:00	110 2240	00885	00848	34 9920	110 1775	00892	00810	35 5208	00867



# DILUTION TUNNEL PARTICULATE SAMPLER DATA

Date: 2019-03-29 Manufacturer: Wof Steel Model: EP1-3

Project #: PT 20189 Run: 1 Tech: M.M Reviewer: MD

*Low m.f.*

SYSTEM 2

Pre-test Weight Record	Probe & Housing Number	Front Filter Number	Back Filter Number	gaskets
2019-03-29 10:00	110 3104	00856	00898	34 2475
2019-04-01 7:00	110 3104	00856	00898	34 2475

SYSTEM 2

Post-test Weight Record	Probe & Housing Number	Front Filter Number	Back Filter Number	gaskets
2019-04-02 8:00	110 3104	00868	00904	34 2494
2019-04-30 15:00	110 3105	00868	00902	34 2450
2019-04-15 8:00	110 3105	00868	00902	34 2490

# DILUTION TUNNEL PARTICULATE SAMPLER DATA

Date: 2019-03-29      Project #: PI 20190      Run: 1      Manufacturer: Wolfe Steel      Model: EP1-3  
 Tech: 1      Reviewer: RS

~~LOW OR MEDIUM-TEST FILTERS~~  
<sup>per High</sup>  
 LOW OR MEDIUM-TEST FILTERS

Pre-test Weight Record		SYSTEM 1 - 1 <sup>st</sup> hour							SYSTEM 1	
Date	Time	Probe & Housing Number	Front Filter Number	Back Filter Number	gaskets	Probe & Housing Number	Front Filter Number	Back Filter Number	gaskets	Blank
2019-03-29	10:00	108 8426	00824	00878	34 1360	108 7396	00899	00893	35 3686	00863
2019-04-01	7:00	108 8426	00824	00878	34 1360	108 7396	00899	00893	35 3686	00863

Post-test Weight Record		SYSTEM 1 - 1 <sup>st</sup> hour							SYSTEM 1	
Date	Time	Probe & Housing Number	Front Filter Number	Back Filter Number	gaskets	Probe & Housing Number	Front Filter Number	Back Filter Number	gaskets	Blank
2019-04-01	15:00	108 8427	00851	00878	34 1383	108 7397	00904	00893	35 3707	00863
2019-04-01	11:00	108 8427	00850	00878	34 1371	108 7396	00903	00890	35 3705	00863
2019-04-15	8:30	108 8427	00850	00878	34 1372	108 7396	00903	00890	35 3690	00863

Date: 2019-03-29 Manufacturer: Wolf Steel Model: LP1-3

Project #: PI 20190 Run: 1 Tech: MM Reviewer: \_\_\_\_\_

*High m.r.*

LOW OR MEDIUM FIRE TEST FILTERS				
SYSTEM 2				
Pre-test Weight Record	Probe & Housing Number	Front Filter Number	Back Filter Number	gaskets
	40	9	10	29
2019-03-29 10:00	110 1100	00855	00859	34 3245
2019-04-01 7:00	110 1100	00855	00859	34 3245

SYSTEM 2				
Post-test Weight Record	Probe & Housing Number	Front Filter Number	Back Filter Number	gaskets
	40	9	10	29
2019-04-01 15:00	110 1102	00886	00860	34 3266
2019-04-10 11:00	110 1102	00886	00860	34 3258
2019-04-15 8:00	110 1102	00886	00860	34 3257



## Paramètres

Tous les facteurs de corrections et autres paramètres qui peuvent être modifiés par l'utilisateur du fichier sont regroupés ici.

Code verrouillage: WOL

### Description du test

Test standard	EPA
Run #	2
Date	03-04-2019
Technicien	S.B.
Project #	PI-20190

### Description de l'unité

Manufacturier	WOLFSTEEL	
Modèle	EPI-3	
Combustion system	Cat	
Appliance type	INSERT	
Firebox volume	1,79	cu ft.
Appliance weight empty	n.a	lbs
Fan (no, Standard, Option)	OPT.	

### Paramètres du test

Logging time	1	min
Manufacturer's rated heat output	n.a	BTU/h Donnée fournie par le manufacturier
Targeted category	1	
Targeted output	n.a	BTU/h
Cp steel	n.a	BTU/lb-°F

### Échantillonnage

Blank sampling rate	0,20	cuft/min
Internal probe diameter	0,18	in.
Calibration Factor (DGM #1):	1,010	Dimensionless
Equipment number (DGM #1):	EM-178	
Calibration Factor (DGM #2):	0,987	Dimensionless
Equipment number (DGM #2):	EM-179	
Calibration Factor (DGM #3):	0,996	Dimensionless
Equipment number (DGM #3):	EM-070	

### Tunnel

Targeted tunnel flow rate	300	scfm
Tunnel diameter	8	in.
Molecular weight	29	29 ASTM E2515
Pitot tube type	Standard	
Pitot tube coefficient	0,99	Dimensionless

Project nu.	PI-20190
Date	03-04-2019
Technicien	S.B.

### Fuel data

Fuel type	Cord
Fuel specie	Oak
HHV	20207,0 kJ/kg
%C	49,5
%H	6,6
%O	43,7
%Ash	0,2
HHV	8689,9 Btu/lb
LHV	7600,4 Btu/lb

Default Fuel Values		
	D. Fir	Oak/Maple
HHV	19 810	20 207
%C	48,73	49,5
%H	6,87	6,62
%O	43,9	43,7
%Ash	0,5	0,2
HHV (Btu/lb)	8519	8690
LHV (Btu/lb)	7451	7600

Adjunct to ASTM E XXXX Wood Heater Cordwood Test Method - May 10, 2017 Version  
 Cordwood Fuel Load Calculators - 10 lb/ft<sup>3</sup> Nominal Load Density  
 Core 45-65% of Total Load Weight, Remainder 35-55% of Total Load Weight  
 Values to be input manually

For All Usable Firebox Volumes - High Fire Test Only						
Nominal Required Load Density (wet basis)	10	lb/ft <sup>3</sup>				
Usable Firebox Volume	1,79	ft <sup>3</sup>				
Total Nom. Load Wt. Target	17,90	lb				
Total Load Wt. Allowable Range	17,00	to	18,80	lb		
Core Target Wt. Allowable Range	8,10	to	11,60	lb		
Remainder Load Wt. Allowable Range	6,30	to	9,80	lb		
					Mid-Point	
Core Load Pc. Wt. Allowable Range	2,70	to	4,50	lb		3,60
Remainder Load Pc. Wt. Allowable Range	1,80	to	9,80	lb		5,80
		Pc. #				
Core Load Piece Wt. Actual	1	3,59	lb	In Range		
	2	3,50	lb	In Range		
	3	3,59	lb	In Range		
Core Load Total. Wt. Actual		10,68	lb	In Range		
		Pc. #				
Remainder Load Piece Wt.	1	5,04	lb	In Range		
(1 to 3 Pcs.)	2	2,07	lb	In Range		
	3		lb	NA		
Remainder Load Tot. Wt. Act		7,11	lb	In Range		
Total Load Wt. Actual		17,79	lb	In Range		
Core % of Total Wt.		60%		In Range		45-65%
Remainder % of Total Wt.		40%		In Range		35-55%
Actual Load % of Nominal Target		99%		In Range		95-105%
Actual Fuel Load Density		9,9	lb/ft <sup>3</sup>			
<u>Kindling and Start-up Fuel</u>						
Maximum Kindling Wt. (20% of Tot. Load Wt.)		3,56	lb			
Actual Kindling Wt.		3,40	lb	In Range		19,1%
Maximum Start-up Fuel Wt. (30% of Tot. Load Wt.)		5,34	lb			
Actual Start-up Fuel Wt.		5,00	lb	In Range		28,1%
Allowable Residual Start-up Fuel Wt. Range	1,8	to	3,6	lb		Mid-Point
Actual Residual Start-up Fuel Wt.		2,7	lb	In Range		2,7
Total Wt. All Fuel Added (wet basis)		26,19	lb			
<u>High Fire Test Run End Point Range</u>						
	Low		High			Mid-Point
Based on Fuel Load Wt. (w/tares)	1,6	to	2,0	lb		1,8
Actual Fuel Load Ending Wt.		1,7	lb	In Range		

Fuel Piece Moisture Reading (%-dry basis)							
	1	2	3	Ave.		Pc. Wt. Dry Basis	
	26,3	18,3	25,3	23,3	In Range	2,91	1,32
	18,1	18,4	20,4	19,0	In Range	2,94	1,33
	27,3	26,8	26,4	26,8	In Range	2,83	1,29
	18,3	18,4	18,4	18,4	In Range	4,26	1,93
	21,7	19,4	24,2	21,8	In Range	1,70	0,77
				NA	NA	NA	NA
Total Load Ave. MC (%-dry basis)				21,5	In Range		
Total Load Ave. MC % (wet basis)				17,7			
Total Test Load Weight (dry basis)						14,64	6,64
<u>Kindling Moisture (%-dry basis)</u>							
	9	9	9	9,0	In Range	3,12	1,41
<u>Start-up Fuel Moisture Readings (%-dry basis)</u>							
	20	20	20	20,0	In Range	4,17	1,89
Total Wt. All Fuel Added (dry basis)						21,93	9,95
Total Wt. All Fuel Burned (dry basis)						17,6	8,0

Load pieces Length in. 16 in.

Adjunct to ASTM E XXXX Wood Heater Cordwood Test Method - May 10, 2017 Version

Cordwood Fuel Load Calculators - 12 lb/ft<sup>3</sup> Nominal Load Density  
Core 45-65% of Total Load Weight, Remainder 35-55% of Total Load Weight

Values to be input manually

THIS DOCUMENT IS NOT AN ASTM STANDARD; IT IS UNDER CONSIDERATION WITHIN AN ASTM TECHNICAL COMMITTEE BUT HAS NOT RECEIVED ALL APPROVALS REQUIRED TO BECOME AN ASTM STANDARD. IT SHALL NOT BE REPRODUCED OR CIRCULATED OR QUOTED, IN WHOLE OR IN PART, OUTSIDE OF ASTM COMMITTEE ACTIVITIES EXCEPT WITH THE APPROVAL OF THE CHAIRMAN OF THE COMMITTEE HAVING JURISDICTION AND THE PRESIDENT OF THE SOCIETY. COPYRIGHT ASTM, 100 BARR HARBOR DRIVE, WEST CONSHOHOCKEN, PA 19380. ALL RIGHTS RESERVED.

For Usable Firebox Volumes up to 3.0 ft <sup>3</sup> - Low and Medium Fire				
Nominal Required Load Density (wet basis)	12	lb/ft <sup>3</sup>		
Usable Firebox Volume	1.79	ft <sup>3</sup>		
Total Nom. Load Wt. Target	21.48	lb		
Total Load Wt. Allowable Range	20.41	to	22.55	lb
Core Target Wt. Allowable Range	9.666	to	13.96	lb
Remainder Load Wt. Allowable Range	7.52	to	11.81	lb
			Mid-Point	
Core Load Fuel Pc. Wt. Allowable Range	3.22	to	5.37	lb
Remainder Load Pc. Wt. Allowable Range	2.15	to	6.44	lb
			4.30	
	Pc. #			
Core Load Piece Wt. Actual	1	4.32	lb	In Range
	2	4.62	lb	In Range
	3	4.46	lb	In Range
Core Load Total. Wt. Actual		13.40	lb	In Range
	Pc. #			
Remainder Load Piece Wt.	1	5.11	lb	In Range
(2 or 3 Pcs.)	2	3.07	lb	In Range
	3		lb	NA
Remainder Load Piece Weight Ratio - Small/Large		60%		In Range ≤ 67%
Remainder Load Tot. Wt. Act		8.18	lb	In Range
Total Load Wt. Actual		21.58	lb	In Range
Core % of Total Wt.		62%		In Range 45-65%
Remainder % of Total Wt.		38%		In Range 35-55%
Actual Load % of Nominal Target		100%		In Range 95-105%
Actual Fuel Load Density		12.1	lb/ft <sup>3</sup>	
Allowable Charcoal Bed Wt. Range (lb)	2.2	to	4.3	lb
Actual Charcoal Bed Wt.		3.9	lb	In Range
Actual Fuel Load Ending Wt.		0.0	lb	Valid Test ≥ 90%
Total Wt. of Fuel Burned During Test Run lb.		21.6	lb	
Load pieces Length in.		16	in.	

Fuel Piece Moisture Reading (%-dry basis)									
1	2	3	Ave.			Pc. Wt. Dry Basis			
18.3	18.6	18.7	18.5	In Range	3.64	lb	1.65	kg	
26.3	18.9	19.4	21.5	In Range	3.80	lb	1.72	kg	
27.6	19.8	27.3	24.9	In Range	3.57	lb	1.62	kg	
Total Load Ave. MC % (dry basis)				27.1	In Range	4.02	lb	1.82	kg
Total Load Ave. MC % (wet basis)				24.2	In Range	2.48	lb	1.12	kg
Total Test Load Weight (dry basis)				NA	NA	NA	lb	NA	kg
Total Fuel Weight Burned During Test Run (dry basis)				23.2	In Range	17.51	lb	7.94	kg
						17.5	lb	7.94	kg

For Usable Firebox Volumes above 3.0 ft <sup>3</sup> - Low and Medium Fire				
Nominal Required Load Density (wet basis)	12	lb/ft <sup>3</sup>		
Usable Firebox Volume		ft <sup>3</sup>		
Total Nom. Load Wt. Target	0	lb		
Total Load Wt. Allowable Range	0.00	to	0.00	lb
Core Target Wt. Allowable Range	0.00	to	0.00	lb
Remainder Load Wt. Allowable Range	0.00	to	0.00	lb
			Mid-Point	
Core Load Fuel Pc. Wt. Allowable Range	0.00	to	0.00	lb
Remainder Load Pc. Wt. Allowable Range	0.00	to	0.00	lb
			0.00	
	Pc. #			
Core Load Piece Wt. Actual	1		lb	In Range
	2		lb	In Range
	3		lb	In Range
Core Load Total. Wt. Actual		0.00	lb	In Range
	Pc. #			
Remainder Load Piece Wt.	1		lb	In Range
(3 or 4 Pcs.)	2		lb	In Range
	3		lb	In Range
	4		lb	NA
Remainder Load Piece Weight Ratio - Small/Large		#NOMBRE!		≤ 67%
Remainder Load Tot. Wt. Act		0.00	lb	In Range
Total Load Wt. Actual		0.00	lb	In Range
Core % of Total Wt.		#DIV/0!		#DIV/0! 45-65%
Remainder % of Total Wt.		#DIV/0!		#DIV/0! 35-55%
Actual Load % of Nominal Target		#DIV/0!		#DIV/0! 95-105%
Actual Fuel Load Density		#DIV/0!	lb/ft <sup>3</sup>	
Allowable Charcoal Bed Wt. Range (lb)	0.1	to	-0.1	lb
Actual Charcoal Bed Wt.			lb	Out of Range 0.0
Actual Fuel Load Ending Wt.			lb	Valid Test ≥ 90%
Total Wt. of Fuel Burned During Test Run lb.		0.0	lb	

Fuel Piece Moisture Reading (%-dry basis)								
1	2	3	Ave.			Pc. Wt. Dry Basis		
			#DIV/0!	#DIV/0!	#DIV/0!	lb	#DIV/0!	kg
			#DIV/0!	#DIV/0!	#DIV/0!	lb	#DIV/0!	kg
			#DIV/0!	#DIV/0!	#DIV/0!	lb	#DIV/0!	kg
Total Load Ave. MC % (dry basis)				NA	NA	NA	lb	NA
Total Load Ave. MC % (wet basis)				#DIV/0!	#DIV/0!	#DIV/0!	lb	#DIV/0!
Total Test Load Weight (dry basis)				#DIV/0!	#DIV/0!	#DIV/0!	lb	#DIV/0!
Total Fuel Weight Burned During Test Run (dry basis)				#DIV/0!	#DIV/0!	#DIV/0!	lb	#DIV/0!

	Start	End
Barometer (kPa):	101,4	100,5
Barometer (in.Hg):	29,943409	29,67763883
Dry Bulb (F):	68,54	80,06
Humidity (%):	24,3	26,6
Air velocity (ft/min)	0	0

High fire test					
DGM #1	Final:	#VALEUR!	cuft	Final: na	Liter
	Initial:	0,000	cuft	Initial:	Liter
DGM #2	Final:	#VALEUR!	cuft	Final: na	Liter
	Initial:	0,000	cuft	Initial:	Liter
DGM room				Final: na	cuft
				Initial:	cuft

min or med burnrate					
DGM #1	Final:	31357,813	cuft	Final: 887954,350	Liter
	Initial:	31291,292	cuft	Initial: 886070,700	Liter
DGM #2	Final:	29584,238	cuft	Final: 837732,300	Liter
	Initial:	29518,524	cuft	Initial: 835871,510	Liter
DGM room				Final: 1026,910	cuft
				Initial: 944,900	cuft

Numéro de la ligne dans "Raw data" à partir duquel les données du test commence	19
Numéro de la ligne dans "Raw data" à partir duquel les données du highfire test commence	49
Numéro de la ligne dans "Raw data" à partir duquel les données du min ou medium fire test commence	166

Autres données à rentrer: dans preload data, load data, traverse et filter set weight

<b>Project nu.</b>	PI-20190
<b>Date</b>	03-04-2019
<b>Technicien</b>	S.B.

## Tunnel Traverse Worksheet (for velocity calculations)

Static Pressure: 0,2 in. H2O  
 Barometer: 29,943 in. Hg

**Pour un tunnel de 12" et plus, prendre 6 lectures**

	TUNNEL VELOCITY	TUNNEL TEMP	SQUARE ROOT
	In. wc	°F	
A center			0,0000
B center			0,0000
A1			0,0000
A2			0,0000
A3			0,0000
A4			0,0000
A5			0,0000
A6			0,0000
B1			0,0000
B2			0,0000
B3			0,0000
B4			0,0000
B5			0,0000
B6			0,0000
AVERAGE	#DIV/0!	#DIV/0!	0,0000

PITOT CONSTANT=  
1,009

**Pour un tunnel moins de 12", prendre 4 lectures**

	TUNNEL VELOCITY	TUNNEL TEMP	SQUARE ROOT
	In. wc	°F	
A center	0,054	78,1	0,2324
B center	0,055	78,5	0,2345
A1	0,052	78,61	0,2280
A2	0,061	78,6	0,2470
A3	0,067	78,72	0,2588
A4	0,066	78,2	0,2569
B1	0,052	78,730	0,2280
B2	0,063	78,740	0,2510
B3	0,047	78,780	0,2168
B4	0,041	78,010	0,2025
AVERAGE	0,0558	78,4990	0,2356

<b>Project nu.</b>	PI-20190
<b>Date</b>	03-04-2019
<b>Technicien</b>	<span style="border: 1px solid red; padding: 2px;">S.B.</span>

**Filter set weight Low/ medium fire**

	System 1 (g) 1st hour				System 1 (g)				System 2 (g)				Ambient blank (g)	Date	Heure
	probe	front	back	gasket	probe	front	back	gasket	probe	front	back	gasket	Filter		
Number	7	430	431	11	15	432	433	35	5	428	429	8	434		
Before (1)															
Before (2)															
Before (3)															
Before (4)															
Before (5)	61,4759	0,0875	0,0858	33,7895	108,7838	0,0869	0,0852	34,8758	61,5040	0,0875	0,0855	35,7068	0,0838	2019-04-02	14H
Before (6)	61,4759	0,0875	0,0858	33,7895	108,7838	0,0869	0,0852	34,8758	61,5040	0,0875	0,0855	35,7068	0,0838	2019-04-03	7H00
After (1)	61,4759	0,0882	0,0863	33,7907	108,7838	0,0875	0,0854	34,8766	61,5042	0,0890	0,0859	35,7075	0,0844	2019-04-03	16H30
After (2)	61,4759	0,0882	0,0859	33,7897	108,7838	0,0875	0,0853	34,8765	61,5041	0,0887	0,0856	35,7071	0,0840	2019-04-10	11h00
After (3)	61,4759	0,0882	0,0859	33,7896	108,7838	0,0875	0,0853	34,8764	61,5042	0,0887	0,0856	35,7072	0,0840	2019-04-15	8h00
After (4)															
After (5)															
After (6)	61,4759	0,0882	0,0859	33,7896	108,7838	0,0875	0,0853	34,8764	61,5042	0,0887	0,0856	35,7072	0,0840	2019-04-15	8h00
Difference	0,0000	0,0007	0,0001	0,0001	0,0000	0,0006	0,0001	0,0006	0,0002	0,0012	0,0001	0,0004	0,0002		
Total (mg)		0,9				2,2				1,9			0,2		
Total ajusté (mg)		<b>0,70</b>				<b>2,00</b>				<b>1,70</b>					

<b>Project nu.</b>	PI-20190
<b>Date</b>	03-04-2019
<b>Technicien</b>	S.B.

SFBA EPA EMISSION RESULTS

RESULTS

**Average emission rate:** 0,62 g/hr

Burn Rate : 1,457 Dry kg/hr

**Test Duration:** 327 min

PRESSURE FACTOR: DGM 1 0,97123  
 DGM 2 0,96322  
 DGM 3 0,99634

BAROMETRIC PRESSURE  
 Average: 29,81052378 in Hg  
 Start: 29,94340873 in Hg  
 End: 29,67763883 in Hg

TEMPERATURE FACTORS DGM 1 0,97217  
 DGM 2 0,97131  
 DGM 3 0,98445

DGM CONTROLLER VALUES

DGM 1 Final: 31357,813 Cuft  
 Initial: 31291,292 Cuft

VOLUMES SAMPLED DGM 1 63,441 Scft  
 DGM 2 60,700 Scft  
 DGM 3 80,099 Scft

DGM 2 Final: 29584,238 Cuft  
 Initial: 29518,524 Cuft

DGM #3 Final: 1026,910 Cuft  
 Initial: 944,900 Cuft

TOTAL TUNNEL VOLUME : 110212

TEMPERATURES

SAMPLE RATIOS  
 Sample Train 1: 1737,220  
 Sample Train 2: 1815,689

DGM 1 543,117 °R  
 DGM 2 543,598 °R

CALIBRATION FACTORS

Patriculate concentration  
 Sample Train 1 **0,000035** g/dscf  
 Sample Train 2 **0,000031** g/dscf  
 Room **0,000002** g/dscf

DGM 1 1,0101  
 DGM 2 0,9873  
 DGM #3 0,9958

TUNNEL FLOW RATE: 337,038 Dscfm

TOTAL EMISSIONS  
 Sample Train 1 **3,55** g  
 Sample Train 2 **3,17** g

PARTICULATE CATCH  
 Total Sample Train 1: 2,20 mg  
 Total Sample Train 2: 1,90 mg  
 Total Sample Train 1 1st hour: 0,90 mg

EMISSION RATES  
 Sample Train 1 **0,65** g/hr  
 Sample Train 2 **0,58** g/hr

1st hour emission rate **1,56** g/hr

DEVIATION: 5,54%

Cs Train 1 3,468E-05 Train 2 3,1302E-05

* Elapsed Time min	* Raw data row	* Weight		* CO		* CO <sub>2</sub>		*1 Flue	*2 Room	*3 Tunnel	*4 Unit	*5 Unit	*6 Unit	*7 Unit	*8 Unit	Mass flow 1	DGM 1	DGM 1	Filter 1	Mass flow 2	DGM 2	DGM 2	Filter 2
		Remaining	CO	CO <sub>2</sub>	Flue	Room	Tunnel	Unit	Unit	Unit	Unit	Unit	Unit	Unit	Unit	Unit	Inlet T	Outlet T	Temp	Reading	Inlet T	Outlet T	Temp
		lbs	%	%	°F	°F	°F	Top	Back	R.Side	L.Side	Bottom	Reading	Inlet T	Outlet T	Temp	Reading	Inlet T	Outlet T	Reading	Inlet T	Outlet T	Temp
							°F	°F	°F	°F	°F	°F	°F	°F	°F	cuft/min	oF	oF	oF	cuft/min	oF	oF	oF
0,00	166,00	21,6	0,4	4,7	367,3	73,3	124,4	589,2	486,2	501,6	526,2	227,0	0,19	79,36	77,48	83,90	0,18	79,12	77,38	85,74			
1,0	167,0	21,2	0,2	1,5	423,1	73,2	112,9	593,6	490,7	501,3	526,1	228,1	0,19	80,06	77,61	83,70	0,18	79,54	77,48	85,52			
2,0	168,0	21,0	0,5	4,6	496,4	73,6	116,4	635,8	494,6	500,3	524,2	230,4	0,19	80,46	77,76	83,51	0,18	79,91	77,61	85,37			
3,0	169,0	20,8	0,4	7,8	560,2	73,7	120,4	690,5	497,9	498,5	522,3	231,6	0,19	80,78	77,91	83,41	0,18	80,23	77,77	85,32			
4,0	170,0	20,6	0,5	10,4	597,0	73,6	123,9	738,5	500,4	496,9	519,9	233,2	0,19	81,11	78,09	83,35	0,18	80,58	77,95	85,29			
5,0	171,0	20,3	0,5	11,5	641,8	73,7	127,9	784,1	502,2	494,3	517,7	234,3	0,19	81,48	78,30	83,33	0,18	80,98	78,16	85,35			
6,0	172,0	20,0	0,6	12,9	659,1	73,7	128,8	819,4	503,3	491,8	514,9	234,5	0,19	81,80	78,45	83,34	0,18	81,27	78,33	85,42			
7,0	173,0	19,8	0,5	12,8	683,7	74,4	130,7	849,6	503,8	489,3	512,2	236,4	0,19	82,00	78,56	83,38	0,18	81,49	78,44	85,48			
8,0	174,0	19,5	0,5	13,3	696,3	74,2	132,2	876,4	503,8	485,9	510,0	237,1	0,19	82,08	78,65	83,46	0,18	81,64	78,55	85,62			
9,0	175,0	19,2	0,4	13,6	710,8	74,1	133,5	899,4	503,4	483,8	508,1	237,6	0,19	82,18	78,75	83,57	0,18	81,76	78,64	85,77			
10,0	176,0	19,0	0,5	14,0	714,0	74,5	134,0	918,5	502,7	481,1	505,7	238,1	0,19	82,30	78,83	83,67	0,18	81,92	78,72	85,90			
11,0	177,0	18,7	0,4	13,8	718,1	74,5	134,4	934,6	501,9	478,7	504,3	238,2	0,19	82,41	78,94	83,82	0,18	82,05	78,82	86,04			
12,0	178,0	18,5	0,4	13,7	719,8	74,5	134,4	948,7	500,9	476,4	502,1	239,0	0,19	82,42	79,01	83,97	0,18	82,12	78,89	86,18			
13,0	179,0	18,2	0,4	13,8	681,6	74,7	126,9	962,8	499,6	474,9	501,2	240,5	0,19	82,40	79,08	84,13	0,18	82,15	78,96	86,21			
14,0	180,0	18,0	0,5	15,3	641,5	74,8	121,3	969,3	498,4	473,7	501,3	240,3	0,19	82,36	79,14	84,29	0,18	82,16	79,04	86,19			
15,0	181,0	17,8	0,5	15,2	591,2	74,8	116,3	966,7	497,1	472,5	500,9	240,3	0,19	82,45	79,23	84,41	0,18	82,24	79,12	86,17			
16,0	182,0	17,7	0,7	15,0	561,0	74,3	112,4	954,8	495,8	471,1	500,9	241,7	0,19	82,53	79,33	84,52	0,18	82,33	79,19	86,18			
17,0	183,0	17,5	0,6	13,7	545,6	74,7	111,5	944,1	494,5	470,8	501,3	242,4	0,19	82,56	79,36	84,54	0,18	82,33	79,27	86,17			
18,0	184,0	17,3	0,7	13,6	539,7	74,8	111,0	940,1	493,2	470,1	501,0	242,2	0,19	82,55	79,41	84,76	0,18	82,36	79,35	86,20			
19,0	185,0	17,1	1,0	14,1	537,2	74,7	110,7	939,8	491,8	470,0	501,9	242,0	0,19	82,57	79,45	84,86	0,18	82,43	79,42	86,24			
20,0	186,0	17,0	1,1	14,4	535,3	74,9	110,5	941,1	490,5	469,6	501,9	243,0	0,19	82,58	79,50	84,91	0,18	82,45	79,48	86,28			
21,0	187,0	16,8	1,2	14,4	533,7	74,6	109,5	942,7	489,2	469,2	501,6	244,3	0,19	82,58	79,55	85,02	0,18	82,43	79,54	86,30			
22,0	188,0	16,6	1,1	14,6	533,2	74,7	109,5	945,2	487,9	468,3	502,3	243,7	0,19	82,59	79,59	85,09	0,18	82,49	79,58	86,33			
23,0	189,0	16,4	1,2	14,6	531,8	74,7	109,5	948,1	486,8	467,5	501,7	244,1	0,19	82,65	79,67	85,18	0,18	82,56	79,64	86,36			
24,0	190,0	16,2	1,1	14,7	531,2	75,0	109,4	950,8	485,5	467,3	502,1	244,7	0,19	82,76	79,73	85,25	0,18	82,59	79,69	86,37			
25,0	191,0	16,0	1,1	14,8	531,1	74,8	108,2	954,2	484,4	466,2	501,4	244,3	0,19	82,77	79,79	85,26	0,18	82,63	79,76	86,39			
26,0	192,0	15,9	1,1	14,9	533,1	74,9	108,6	958,2	483,3	466,0	501,4	244,6	0,19	82,72	79,84	85,32	0,18	82,63	79,84	86,38			
27,0	193,0	15,7	1,1	15,2	532,8	75,1	108,6	961,4	482,2	465,2	500,8	243,6	0,19	82,77	79,90	85,34	0,18	82,66	79,86	86,42			
28,0	194,0	15,5	1,2	15,1	533,2	74,8	108,6	964,4	481,1	464,5	501,2	243,5	0,19	82,74	79,93	85,39	0,18	82,63	79,93	86,42			
29,0	195,0	15,3	1,2	15,3	533,3	75,1	108,6	966,2	480,0	463,9	501,3	243,4	0,19	82,78	80,00	85,44	0,18	82,69	80,00	86,45			
30,0	196,0	15,1	1,2	15,3	531,9	75,1	108,3	967,1	479,1	463,3	501,3	242,8	0,19	82,77	80,04	85,43	0,18	82,74	80,06	86,47			
31,0	197,0	14,9	1,2	15,3	530,8	75,2	108,2	967,6	478,0	462,7	501,6	242,8	0,19	82,88	80,11	85,47	0,18	82,80	80,11	86,49			
32,0	198,0	14,8	1,2	15,2	530,4	75,3	108,6	968,0	477,1	462,3	501,9	241,6	0,19	83,02	80,18	85,52	0,18	82,86	80,17	86,49			
33,0	199,0	14,6	1,2	15,1	528,6	75,4	108,3	967,8	476,2	461,4	501,9	241,7	0,19	83,08	80,21	85,52	0,18	82,92	80,21	86,49			
34,0	200,0	14,4	1,1	15,1	527,6	75,5	108,1	968,1	475,4	461,0	502,8	242,2	0,19	83,14	80,28	85,52	0,18	82,95	80,26	86,47			
35,0	201,0	14,3	1,1	15,2	528,6	75,6	107,7	969,2	474,4	459,8	503,7	241,9	0,19	83,20	80,34	85,54	0,18	83,01	80,36	86,49			
36,0	202,0	14,1	1,0	15,3	527,7	75,2	107,7	970,2	473,6	459,7	504,8	241,9	0,19	83,15	80,38	85,57	0,18	83,00	80,38	86,47			
37,0	203,0	13,9	1,1	15,3	526,6	75,7	107,4	971,4	472,9	459,6	505,6	241,7	0,19	83,05	80,40	85,59	0,18	82,98	80,44	86,47			
38,0	204,0	13,8	1,0	15,2	525,3	75,3	107,5	972,2	472,1	459,1	506,8	241,1	0,19	83,11	80,46	85,64	0,18	83,03	80,51	86,46			
39,0	205,0	13,6	1,0	15,1	524,1	75,3	108,2	973,7	471,5	458,2	507,6	241,0	0,19	83,22	80,51	85,58	0,18	83,12	80,57	86,45			
40,0	206,0	13,4	0,9	15,3	522,2	75,0	107,8	974,7	470,8	458,0	508,9	239,6	0,19	83,32	80,59	85,62	0,18	83,23	80,64	86,46			
41,0	207,0	13,2	1,1	14,9	518,7	75,1	107,2	973,5	470,1	458,1	510,1	238,7	0,19	83,39	80,64	85,55	0,18	83,29	80,71	86,40			
42,0	208,0	13,1	1,0	14,6	517,2	75,3	106,3	973,0	469,6	457,7	511,4	239,6	0,19	83,38	80,71	85,55	0,18	83,34	80,78	86,38			
43,0	209,0	12,9	0,7	14,6	516,1	75,4	106,7	973,2	468,9	457,1	512,5	239,5	0,19	83,38	80,74	85,58	0,18	83,35	80,81	86,35			
44,0	210,0	12,8	0,7	14,6	514,0	75,2	106,2	972,2	468,3	456,6	513,8	239,4	0,19	83,31	80,81	85,59	0,18	83,31	80,86	86,35			
45,0	211,0	12,6	0,6	14,5	512,8	75,4	105,6	970,7	467,9	456,9	514,6	238,9	0,19	83,33	80,86	85,59	0,18	83,34	80,92	86,33			
46,0	212,0	12,5	0,7	14,6	511,5	75,6	105,8	971,3	467,4	456,2	516,1	238,1	0,19	83,44	80,93	85,60	0,18	83,39	81,00	86,34			
47,0	213,0	12,3	0,7	14,6	512,1	75,5	105,0	970,8	466,9	456,7	517,3	238,0	0,19	83,39	80,99	85,56	0,18	83,41	81,07	86,28			
48,0	214,0	12,2	0,8	14,4	510,3	75,4	106,2	969,2	466,5	456,7	519,1	237,6	0,19	83,42	81,05	85,56	0,18	83,42	81,12	86,26			
49,0	215,0	12,0	0,8	14,4	510,1	75,4	105,9	968,1	466,0	456,6	520,5	237,2	0,19	83,50	81,10	85,54	0,18	83,50	81,18	86,26			
50,0	216,0	11,9	0,8	14,7	508,8	75,8	106,1	967,4	465,6	456,6	521,2	236,7	0,19	83,50	81,14	85,57	0,18	83,50	81,24	86,27			
51,0	217,0	11,7	0,8	14,7	506,8	75,6	105,7	965,7	465,3	456,6	522,3	237,4	0,19	83,51	81,19	85,54	0,18	83,56	81,27	86,23			
52,0	218,0	11,6	0,8	14,6	504,9	75,7	105,5	963,5	464,9	456,3	524,0	237,9	0,19	83,58	81,22	85,53	0,18	83,60	81,33	86,23			
53,0	219,0	11,5	0,7	14,5	504,5	75,4	104,9	962,6	464,3	456,3	525,9	237,9	0,19	83,60	81,28	85,50	0,18	83,62	81,39	86,24			
54,0	220,0	11,3	0,7	14,6	503,2	76,0	105,5	962,2	463,9	456,0	526,9	237,9	0,19	83,67	81,30	85,50	0,18	83,68	81,42	86,22			
55,0	221,0	11,1	0,6	14,3	499,6	75,8	105,3	960,6	463,6	456,6	527,4	236,7	0,19	8									



82,0	248,0	7,9	0,3	13,5	467,5	76,5	102,1	934,4	459,2	466,4	557,3	234,4	0,19	83,54	82,23	83,61	0,18	83,83	82,52	85,79
83,0	249,0	7,8	0,3	12,8	461,3	76,5	102,2	927,5	459,3	466,7	557,4	234,1	0,19	83,59	82,26	83,61	0,18	83,88	82,57	85,80
84,0	250,0	7,7	0,2	12,5	456,0	76,5	102,3	919,2	459,3	467,3	558,2	233,2	0,19	83,61	82,26	83,57	0,18	83,88	82,57	85,73
85,0	251,0	7,6	0,2	12,2	453,0	76,5	102,5	911,9	459,5	468,2	558,0	234,0	0,19	83,68	82,30	83,54	0,18	83,92	82,59	85,74
86,0	252,0	7,5	0,2	12,0	450,4	76,4	101,2	905,7	459,6	469,4	559,0	234,3	0,19	83,76	82,35	83,54	0,18	84,00	82,62	85,73
87,0	253,0	7,4	0,2	11,9	446,9	76,1	101,6	899,9	459,7	470,2	558,5	233,8	0,19	83,82	82,36	83,49	0,18	84,05	82,66	85,71
88,0	254,0	7,4	0,2	11,9	444,2	75,6	101,8	893,8	459,9	471,1	558,3	233,9	0,19	83,80	82,37	83,43	0,18	84,10	82,66	85,66
89,0	255,0	7,2	0,2	11,8	441,9	75,9	101,1	887,9	460,0	471,6	558,5	232,9	0,19	83,70	82,38	83,37	0,18	84,05	82,68	85,65
90,0	256,0	7,2	0,3	11,6	440,2	76,0	100,7	882,8	460,2	472,1	558,2	233,9	0,19	83,63	82,42	83,36	0,18	84,03	82,72	85,61
91,0	257,0	7,1	0,3	11,7	438,9	76,2	100,3	879,2	460,5	472,8	557,6	234,7	0,19	83,58	82,44	83,35	0,18	83,97	82,73	85,58
92,0	258,0	7,0	0,3	11,7	437,6	76,4	100,2	876,8	460,6	473,5	557,8	233,7	0,19	83,66	82,48	83,37	0,18	84,03	82,77	85,53
93,0	259,0	6,9	0,3	11,6	435,7	76,6	100,6	874,1	460,7	473,9	557,6	234,0	0,19	83,72	82,51	83,35	0,18	84,09	82,79	85,50
94,0	260,0	6,8	0,3	11,6	433,6	76,3	100,6	870,8	461,0	474,4	557,1	233,6	0,19	83,82	82,53	83,36	0,18	84,14	82,83	85,46
95,0	261,0	6,7	0,3	11,5	432,2	76,6	99,8	867,6	461,2	475,0	557,7	234,4	0,19	83,84	82,55	83,38	0,18	84,14	82,87	85,44
96,0	262,0	6,7	0,2	11,5	430,1	76,4	100,0	864,3	461,4	475,3	556,8	234,5	0,19	83,86	82,58	83,38	0,18	84,20	82,88	85,41
97,0	263,0	6,6	0,2	11,4	428,8	76,8	99,6	861,6	461,7	476,0	556,9	234,6	0,19	83,73	82,58	83,35	0,19	84,12	82,89	85,37
98,0	264,0	6,5	0,2	11,3	427,1	76,7	99,8	858,2	462,0	476,5	556,5	234,8	0,19	83,64	82,59	83,35	0,18	84,05	82,91	85,30
99,0	265,0	6,5	0,3	11,4	424,0	76,4	99,5	854,1	462,4	476,8	555,8	234,2	0,19	83,54	82,58	83,32	0,18	83,99	82,93	85,27
100,0	266,0	6,3	0,2	11,3	421,6	76,3	100,1	849,4	462,9	477,1	555,2	235,0	0,19	83,50	82,61	83,29	0,18	83,98	82,93	85,27
101,0	267,0	6,3	0,2	11,2	419,2	76,5	99,4	845,6	463,2	478,1	555,4	234,8	0,19	83,39	82,60	83,31	0,18	83,90	82,95	85,26
102,0	268,0	6,2	0,2	11,0	414,9	76,1	99,4	839,5	463,7	478,4	554,3	235,3	0,19	83,43	82,63	83,28	0,18	83,91	82,96	85,22
103,0	269,0	6,2	0,2	10,7	411,7	76,5	98,3	833,0	464,1	479,1	554,1	235,8	0,19	83,43	82,63	83,29	0,18	83,90	82,99	85,19
104,0	270,0	6,1	0,2	10,2	407,7	76,3	98,8	826,3	464,5	479,6	553,9	235,8	0,19	83,47	82,66	83,23	0,18	83,95	83,00	85,13
105,0	271,0	6,0	0,2	10,1	404,8	76,4	98,9	820,4	464,9	480,3	553,2	235,6	0,19	83,50	82,67	83,19	0,18	83,99	83,00	85,10
106,0	272,0	6,0	0,2	10,2	403,3	76,5	98,8	816,6	465,4	480,8	553,5	235,5	0,19	83,53	82,68	83,19	0,18	83,97	83,03	85,07
107,0	273,0	5,9	0,2	10,3	402,4	76,7	98,3	813,5	465,8	480,9	553,4	235,8	0,19	83,56	82,69	83,13	0,18	83,99	83,04	85,02
108,0	274,0	5,8	0,2	10,3	401,9	76,3	98,6	811,1	466,5	481,7	553,8	234,9	0,19	83,58	82,70	83,13	0,18	84,01	83,04	84,99
109,0	275,0	5,8	0,2	10,4	400,4	76,7	98,2	808,0	467,2	481,9	552,7	235,2	0,19	83,53	82,72	83,14	0,18	83,98	83,07	84,95
110,0	276,0	5,7	0,2	10,3	399,9	77,1	96,7	804,4	467,8	482,2	552,4	235,7	0,19	83,51	82,74	83,11	0,18	83,93	83,09	84,89
111,0	277,0	5,6	0,1	10,2	398,3	76,8	97,3	801,4	468,7	482,4	552,5	235,6	0,19	83,46	82,75	83,09	0,18	83,91	83,06	84,85
112,0	278,0	5,6	0,1	10,2	396,4	76,6	97,9	799,0	469,5	483,2	551,5	236,1	0,19	83,46	82,78	83,09	0,18	83,92	83,09	84,82
113,0	279,0	5,5	0,1	10,2	395,8	76,4	98,1	796,9	470,4	483,0	550,7	235,9	0,19	83,48	82,80	83,04	0,18	83,90	83,09	84,78
114,0	280,0	5,4	0,1	10,3	395,2	76,6	97,1	793,8	471,4	483,2	550,3	236,3	0,19	83,44	82,81	83,03	0,18	83,89	83,11	84,73
115,0	281,0	5,4	0,1	10,3	393,6	76,7	97,4	790,6	472,3	483,4	550,9	235,8	0,19	83,42	82,80	82,97	0,18	83,91	83,11	84,69
116,0	282,0	5,3	0,1	10,3	392,4	76,8	97,6	787,3	473,4	484,0	549,6	235,4	0,19	83,42	82,81	82,90	0,18	83,94	83,14	84,67
117,0	283,0	5,2	0,1	10,3	392,3	76,3	96,3	784,5	474,4	484,0	549,4	235,8	0,19	83,34	82,79	82,86	0,18	83,89	83,14	84,61
118,0	284,0	5,2	0,1	10,2	390,4	76,3	97,1	780,3	475,5	484,2	548,8	234,7	0,19	83,31	82,80	82,82	0,18	83,86	83,15	84,56
119,0	285,0	5,1	0,3	10,0	389,8	76,7	96,5	778,1	476,7	483,8	547,9	235,7	0,19	83,22	82,79	82,78	0,18	83,81	83,17	84,53
120,0	286,0	5,1	0,2	10,1	388,0	76,7	96,8	774,9	477,8	483,7	547,0	235,9	0,19	83,14	82,80	82,78	0,18	83,78	83,18	84,49
121,0	287,0	5,0	0,1	10,1	386,7	76,5	97,1	770,9	478,9	484,0	547,1	235,7	0,19	83,17	82,78	82,74	0,18	83,75	83,19	84,42
122,0	288,0	4,9	0,2	10,1	385,6	76,3	96,8	766,8	480,1	484,6	546,2	236,0	0,19	83,26	82,79	82,74	0,18	83,80	83,19	84,39
123,0	289,0	4,9	0,1	10,1	384,4	76,3	96,9	762,9	481,3	484,1	545,3	236,0	0,19	83,34	82,79	82,71	0,18	83,87	83,19	84,36
124,0	290,0	4,8	0,1	10,1	384,1	76,3	97,2	759,8	482,6	484,2	545,0	235,9	0,19	83,39	82,78	82,68	0,18	83,88	83,20	84,35
125,0	291,0	4,8	0,1	10,1	383,2	76,3	96,5	757,4	483,8	484,1	544,7	235,5	0,19	83,40	82,80	82,66	0,18	83,91	83,19	84,31
126,0	292,0	4,7	0,1	10,1	382,4	76,2	96,4	755,3	485,1	484,0	543,7	235,3	0,19	83,47	82,83	82,62	0,18	83,96	83,19	84,30
127,0	293,0	4,7	0,2	10,1	382,5	76,4	96,0	753,7	486,4	484,0	543,3	235,6	0,19	83,44	82,78	82,57	0,18	83,93	83,20	84,23
128,0	294,0	4,6	0,2	10,1	381,7	76,8	96,5	752,2	487,9	483,8	543,0	235,4	0,19	83,39	82,78	82,53	0,18	83,92	83,20	84,23
129,0	295,0	4,5	0,2	10,1	380,8	76,3	96,8	750,7	489,4	483,7	542,1	235,6	0,19	83,38	82,77	82,49	0,18	83,90	83,21	84,19
130,0	296,0	4,5	0,2	10,1	380,7	76,4	96,8	749,3	490,9	483,8	541,5	236,1	0,19	83,35	82,78	82,49	0,18	83,93	83,19	84,13
131,0	297,0	4,4	0,2	10,0	380,4	76,7	96,7	748,3	492,2	485,6	541,8	235,9	0,19	83,33	82,79	82,51	0,18	83,93	83,20	84,12
132,0	298,0	4,3	0,2	10,1	378,8	76,5	95,9	746,7	493,6	483,4	541,0	235,8	0,19	83,32	82,78	82,51	0,18	83,93	83,20	84,12
133,0	299,0	4,3	0,3	9,9	376,9	76,6	95,8	743,9	495,0	483,0	540,1	235,9	0,19	83,30	82,79	82,51	0,18	83,95	83,21	84,07
134,0	300,0	4,2	0,3	9,6	375,3	76,7	95,7	741,5	496,3	483,0	540,4	235,6	0,19	83,21	82,74	82,46	0,18	83,87	83,19	84,04
135,0	301,0	4,2	0,3	9,6	374,1	76,8	95,3	739,0	497,6	482,8	539,8	235,3	0,19	83,22	82,74	82,46	0,18	83,86	83,20	84,01
136,0	302,0	4,2	0,3	9,6	373,2	76,6	95,7	736,9	498,8	482,9	539,4	235,8	0,19	83,24	82,73	82,43	0,18	83,89	83,22	83,97
137,0	303,0	4,1	0,3	9,6	371,9	76,6	95,6	734,2	500,2	482,3	538,4	236,1	0,19	83,16	82,71	82,39	0,18	83,84	83,21	83,98
138,0	304,0	4,1	0,3	9,5	370,9	76,3	95,2	731,6	501,3	481,9	539,3	235,6	0,19	83,06	82,70	82,37	0,18	83,76	83,18	83,94
139,0	305,0	4,0	0,3	9,5	369,4	76,3	95,5	729,2	502,6	481,9	538,2	236,2	0,19	83,05	82,69	82,35	0,18	83,74	83,19	83,91
140,0	306,0	4,0	0,3	9,4	368,5	76,3	95,2	727,0	503,7	481,6	537,9	236,1	0,19	83,02	82,68	82,32	0,18	83,73	83,20	83,85
141,0	307,0	3,9	0,3	9,4	367,4	75,7	95,0	725,0	504,9	481,5	537,5	236,3	0,19	82,96</						

168,0	334,0	2,9	0,3	7,2	332,9	76,7	97,1	657,4	542,5	478,5	523,4	241,5	0,19	83,06	82,69	83,44	0,18	83,59	83,19	84,47
169,0	335,0	2,9	0,3	7,1	330,2	76,8	97,7	652,5	544,3	478,5	523,2	242,5	0,19	83,29	82,81	83,38	0,18	83,76	83,29	84,45
170,0	336,0	2,9	0,3	7,1	328,4	77,1	98,4	648,4	545,7	478,1	523,0	242,3	0,19	83,56	82,87	83,33	0,18	83,97	83,37	84,41
171,0	337,0	2,9	0,4	7,1	326,4	77,1	99,1	644,7	547,1	477,6	521,8	242,9	0,19	83,87	83,00	83,34	0,18	84,19	83,50	84,41
172,0	338,0	2,8	0,3	7,4	324,5	76,7	99,8	641,3	548,3	477,0	521,4	243,1	0,19	84,17	83,13	83,31	0,18	84,44	83,61	84,42
173,0	339,0	2,8	0,3	7,4	323,5	77,1	100,2	638,0	549,5	476,7	521,0	243,3	0,19	84,45	83,24	83,31	0,18	84,67	83,73	84,44
174,0	340,0	2,8	0,3	7,4	322,3	76,8	99,5	634,7	550,5	476,1	520,6	243,7	0,19	84,71	83,34	83,33	0,18	84,87	83,82	84,46
175,0	341,0	2,8	0,3	7,4	321,9	76,7	98,2	631,3	551,5	475,7	519,9	244,1	0,19	84,83	83,43	83,31	0,18	85,02	83,89	84,44
176,0	342,0	2,7	0,4	7,4	321,3	77,1	97,8	628,3	552,4	475,2	519,1	244,3	0,19	84,79	83,48	83,28	0,18	85,08	83,95	84,42
177,0	343,0	2,7	0,4	7,4	320,6	76,5	96,7	625,4	553,1	474,6	518,4	244,2	0,19	84,73	83,50	83,24	0,18	85,12	83,99	84,36
178,0	344,0	2,7	0,4	7,4	319,9	76,5	96,3	622,9	553,8	473,9	517,7	244,1	0,19	84,61	83,56	83,21	0,18	85,11	84,01	84,34
179,0	345,0	2,7	0,4	7,4	319,3	77,1	95,9	620,8	554,6	473,0	517,0	244,1	0,19	84,51	83,59	83,17	0,19	85,12	84,03	84,31
180,0	346,0	2,6	0,4	7,3	318,7	77,0	95,6	618,6	555,3	472,4	516,5	243,7	0,19	84,40	83,61	83,14	0,18	85,12	84,06	84,25
181,0	347,0	2,6	0,4	7,3	318,5	76,7	94,8	616,5	556,1	471,4	514,5	244,1	0,19	84,23	83,61	83,12	0,18	85,03	84,08	84,22
182,0	348,0	2,6	0,4	7,3	318,0	77,1	94,5	614,5	556,8	470,7	514,5	244,6	0,19	84,04	83,59	83,07	0,18	84,94	84,08	84,19
183,0	349,0	2,6	0,4	7,3	317,5	76,9	94,3	612,5	557,5	469,8	513,3	245,2	0,19	83,84	83,58	82,99	0,18	84,82	84,06	84,11
184,0	350,0	2,6	0,4	7,3	317,2	76,9	94,4	610,5	558,3	469,2	512,6	245,9	0,19	83,71	83,57	82,96	0,18	84,72	84,08	84,08
185,0	351,0	2,5	0,5	7,3	316,6	76,4	94,3	608,7	559,0	468,3	511,6	245,7	0,19	83,66	83,55	82,97	0,19	84,71	84,09	84,04
186,0	352,0	2,5	0,5	7,3	316,3	76,9	93,9	607,0	559,6	467,7	510,8	245,7	0,19	83,62	83,53	82,96	0,18	84,64	84,04	83,99
187,0	353,0	2,5	0,5	7,3	315,9	76,8	93,6	605,7	560,3	466,8	510,0	245,7	0,19	83,56	83,50	82,94	0,18	84,59	84,04	83,96
188,0	354,0	2,6	0,5	7,3	315,4	77,0	93,7	604,1	561,1	466,5	508,9	246,1	0,19	83,53	83,51	82,92	0,18	84,56	84,03	83,89
189,0	355,0	2,5	0,5	7,3	315,3	76,7	93,6	602,4	561,5	465,5	508,4	246,2	0,19	83,44	83,50	82,86	0,18	84,52	84,04	83,88
190,0	356,0	2,5	0,5	7,3	314,7	77,0	93,4	601,0	562,2	464,4	507,5	246,3	0,19	83,40	83,48	82,85	0,18	84,49	84,02	83,82
191,0	357,0	2,4	0,5	7,3	314,2	76,4	93,5	599,4	562,7	463,7	506,7	246,3	0,19	83,37	83,49	82,82	0,19	84,41	84,02	83,81
192,0	358,0	2,4	0,5	7,3	313,8	76,5	93,1	598,2	563,2	462,9	506,0	246,3	0,19	83,36	83,45	82,74	0,18	84,38	83,99	83,73
193,0	359,0	2,4	0,5	7,4	314,7	77,0	92,9	597,8	563,7	462,2	505,8	245,5	0,19	83,39	83,45	82,69	0,18	84,39	83,97	83,71
194,0	360,0	2,3	0,4	7,5	314,3	76,5	94,4	598,0	564,3	461,5	505,0	245,9	0,19	83,55	83,48	82,66	0,18	84,42	83,99	83,68
195,0	361,0	2,3	0,5	7,5	313,7	76,9	95,6	598,2	564,9	460,9	504,0	246,2	0,19	83,71	83,56	82,65	0,18	84,52	84,02	83,71
196,0	362,0	2,3	0,6	7,4	312,7	77,1	96,8	598,2	565,5	460,0	503,0	246,1	0,19	83,95	83,64	82,68	0,18	84,67	84,10	83,71
197,0	363,0	2,3	0,6	7,4	311,4	77,0	98,0	597,7	566,0	459,3	503,0	246,2	0,19	84,18	83,73	82,71	0,19	84,85	84,17	83,72
198,0	364,0	2,3	0,6	7,4	310,7	76,8	98,7	597,1	566,6	458,5	502,4	246,3	0,19	84,49	83,82	82,76	0,18	85,04	84,26	83,80
199,0	365,0	2,3	0,6	7,4	310,0	77,2	99,1	596,1	567,0	458,2	502,1	246,6	0,19	84,68	83,91	82,77	0,18	85,20	84,35	83,81
200,0	366,0	2,2	0,7	7,3	310,1	77,3	98,1	595,0	567,5	457,9	501,8	247,0	0,19	84,79	84,01	82,78	0,18	85,31	84,43	83,87
201,0	367,0	2,2	0,7	7,3	309,5	77,4	97,6	593,7	567,8	456,8	501,7	246,9	0,19	84,79	84,06	82,80	0,18	85,37	84,49	83,87
202,0	368,0	2,2	0,8	7,2	309,3	77,0	96,4	592,1	568,0	456,4	501,3	247,2	0,19	84,77	84,06	82,78	0,18	85,38	84,54	83,85
203,0	369,0	2,2	0,9	7,0	308,9	77,5	95,8	590,6	568,0	455,8	500,4	247,4	0,19	84,73	84,09	82,79	0,18	85,33	84,56	83,88
204,0	370,0	2,2	0,8	7,0	308,5	76,8	95,3	589,4	568,1	455,4	500,7	247,6	0,19	84,63	84,07	82,84	0,18	85,33	84,59	83,89
205,0	371,0	2,1	0,8	7,0	308,1	76,5	94,5	588,1	568,0	454,6	500,4	247,6	0,19	84,49	84,08	82,85	0,18	85,25	84,57	83,85
206,0	372,0	2,1	0,8	7,0	308,0	76,7	94,2	586,7	567,9	454,1	500,2	248,0	0,19	84,34	84,04	82,85	0,18	85,19	84,57	83,86
207,0	373,0	2,1	0,9	7,0	307,6	76,6	93,9	585,3	567,7	454,0	499,7	248,3	0,19	84,23	84,03	82,88	0,18	85,16	84,53	83,84
208,0	374,0	2,1	0,9	7,0	307,1	76,6	93,7	584,1	567,4	452,9	499,1	248,5	0,19	84,07	83,98	82,89	0,18	85,07	84,52	83,83
209,0	375,0	2,1	0,9	7,0	307,1	76,6	93,0	583,0	567,0	452,2	499,1	248,0	0,19	83,91	83,95	82,86	0,18	84,94	84,50	83,84
210,0	376,0	2,0	0,9	6,9	306,9	76,2	93,2	582,1	566,6	451,5	498,7	248,1	0,19	83,65	83,90	82,82	0,18	84,75	84,46	83,79
211,0	377,0	2,0	1,0	6,9	306,8	76,4	92,8	581,2	566,1	450,9	498,3	248,5	0,19	83,53	83,87	82,74	0,18	84,63	84,45	83,76
212,0	378,0	2,0	1,0	7,0	306,5	76,4	92,6	580,3	565,6	450,1	498,1	248,4	0,19	83,43	83,81	82,72	0,18	84,55	84,40	83,72
213,0	379,0	2,0	1,0	7,0	306,6	76,4	92,7	579,6	565,0	449,9	497,5	248,5	0,19	83,34	83,77	82,70	0,18	84,45	84,37	83,68
214,0	380,0	1,9	1,0	7,0	306,0	76,4	92,3	578,7	564,5	448,9	497,2	248,3	0,19	83,20	83,74	82,65	0,18	84,30	84,31	83,63
215,0	381,0	2,0	1,0	7,0	305,3	76,5	92,5	577,5	563,8	448,1	496,4	248,1	0,19	83,15	83,68	82,62	0,18	84,21	84,28	83,65
216,0	382,0	1,9	0,7	7,1	304,9	76,4	92,2	576,6	563,3	447,9	495,5	247,9	0,19	83,06	83,63	82,59	0,18	84,16	84,26	83,62
217,0	383,0	1,9	0,7	7,1	304,3	76,3	92,3	575,7	562,8	447,3	495,0	247,9	0,19	83,11	83,63	82,55	0,18	84,11	84,23	83,57
218,0	384,0	1,9	0,8	7,1	303,7	76,9	92,5	574,8	561,9	446,3	495,6	248,0	0,19	83,06	83,57	82,49	0,18	84,14	84,21	83,53
219,0	385,0	1,8	0,8	7,1	304,0	76,4	91,7	573,8	561,3	446,1	495,4	248,1	0,19	82,90	83,52	82,47	0,18	83,97	84,17	83,50
220,0	386,0	1,8	0,8	7,0	303,2	76,8	92,3	572,8	560,5	445,6	495,1	247,9	0,19	82,92	83,52	82,41	0,18	83,92	84,12	83,43
221,0	387,0	1,8	0,8	7,0	302,5	76,5	94,1	571,7	560,0	444,9	494,0	248,1	0,19	83,09	83,55	82,37	0,18	83,97	84,13	83,40
222,0	388,0	1,8	0,9	7,0	301,5	76,7	95,3	570,6	559,6	443,9	493,8	248,2	0,19	83,28	83,64	82,37	0,18	84,10	84,18	83,42
223,0	389,0	1,8	0,9	7,0	300,5	76,6	96,7	569,6	559,1	443,7	493,9	248,3	0,19	83,50	83,70	82,40	0,19	84,23	84,23	83,42
224,0	390,0	1,7	0,9	7,0	300,1	76,8	97,5	568,6	558,9	443,1	493,8	248,6	0,19	83,80	83,81	82,44	0,18	84,44	84,30	83,47
225,0	391,0	1,7	0,9	7,0	299,5	76,9	98,3	567,4	558,4	442,5	493,3	248,3	0,19	84,13	83,92	82,46	0,19	84,66	84,39	83,50
226,0	392,0	1,7	0,9	7,0	298,8	77,2	98,7	566,2	558,3	441,9	492,7	248,5	0,19	84,42	84,04	82,53	0,19	84,92	84,52	83,59
227,0	393,0	1,7	0,9	7,0	299,1	77,4	97,7	565,1	558,0	441,6	492,9	248,9	0,19	84,63	84,11	82,59	0,18	85,07	84,5	

254,0	420,0	1,2	0,8	6,2	285,1	77,4	97,8	536,5	546,3	428,8	476,0	247,5	0,19	84,57	84,26	82,53	0,18	85,14	84,79	83,52
255,0	421,0	1,2	0,8	6,2	285,5	77,8	96,8	535,3	545,3	427,8	474,5	247,2	0,19	84,69	84,32	82,58	0,18	85,26	84,86	83,56
256,0	422,0	1,1	0,8	6,2	285,8	77,6	96,1	534,4	544,1	427,2	474,4	247,3	0,19	84,79	84,40	82,59	0,18	85,35	84,92	83,60
257,0	423,0	1,1	0,8	6,1	285,2	77,8	95,2	533,4	543,0	427,3	472,9	247,5	0,19	84,68	84,42	82,60	0,18	85,35	84,96	83,60
258,0	424,0	1,1	0,8	6,1	285,4	77,1	94,3	532,2	542,0	426,4	471,9	247,5	0,19	84,49	84,43	82,63	0,18	85,28	84,97	83,60
259,0	425,0	1,1	0,8	6,1	285,2	76,8	93,8	530,9	540,9	425,8	471,2	247,4	0,19	84,36	84,43	82,62	0,18	85,20	84,97	83,57
260,0	426,0	1,0	0,8	6,1	285,3	76,4	93,7	529,9	539,7	425,5	470,4	247,2	0,19	84,23	84,39	82,64	0,18	85,16	84,94	83,56
261,0	427,0	1,0	0,8	6,1	284,6	76,8	92,9	529,0	538,7	424,6	469,1	246,9	0,19	84,06	84,38	82,64	0,18	85,02	84,91	83,54
262,0	428,0	1,0	0,8	6,1	285,1	76,6	92,7	528,3	537,6	423,7	467,9	246,3	0,19	83,97	84,34	82,59	0,18	84,98	84,93	83,56
263,0	429,0	1,0	0,8	6,0	285,0	76,3	92,0	527,5	536,5	422,7	467,0	245,5	0,19	83,76	84,28	82,58	0,18	84,85	84,89	83,49
264,0	430,0	1,0	0,8	6,0	285,0	76,3	91,6	526,8	535,5	422,3	466,2	245,6	0,19	83,49	84,21	82,54	0,18	84,66	84,83	83,45
265,0	431,0	1,0	0,8	6,0	285,2	76,1	91,2	526,0	534,4	421,6	465,4	244,7	0,19	83,25	84,18	82,48	0,18	84,51	84,80	83,41
266,0	432,0	1,0	0,8	5,9	285,1	76,5	90,7	525,5	533,4	421,3	464,0	244,9	0,19	83,09	84,12	82,47	0,18	84,39	84,75	83,36
267,0	433,0	0,9	0,8	5,9	284,3	76,3	90,7	524,7	532,4	420,1	462,8	244,5	0,19	82,93	84,03	82,40	0,18	84,21	84,67	83,34
268,0	434,0	0,9	0,8	5,9	283,8	76,3	91,0	524,0	531,4	419,5	462,1	244,2	0,19	82,81	83,96	82,37	0,18	84,09	84,64	83,28
269,0	435,0	0,9	0,9	5,9	283,5	76,6	90,4	523,2	529,4	418,9	460,9	243,9	0,19	82,68	83,89	82,33	0,18	83,96	84,59	83,23
270,0	436,0	0,9	0,9	5,9	283,4	76,6	90,7	522,4	529,4	418,3	459,7	244,0	0,19	82,61	83,81	82,29	0,18	83,83	84,52	83,22
271,0	437,0	0,9	0,8	5,9	283,5	76,4	90,6	521,7	528,5	417,8	459,0	243,9	0,19	82,62	83,76	82,26	0,18	83,77	84,48	83,20
272,0	438,0	0,8	0,8	5,8	283,0	76,2	90,6	520,9	527,4	417,0	458,1	243,6	0,19	82,65	83,74	82,22	0,18	83,79	84,44	83,17
273,0	439,0	0,8	0,8	5,8	282,8	76,7	90,1	520,1	526,4	416,6	457,0	243,1	0,19	82,70	83,69	82,17	0,18	83,82	84,41	83,12
274,0	440,0	0,8	0,8	5,8	282,2	76,3	90,3	519,3	525,5	415,8	456,2	242,9	0,19	82,73	83,67	82,09	0,18	83,85	84,39	83,07
275,0	441,0	0,8	0,8	5,8	281,7	77,0	91,2	518,4	524,6	415,4	455,0	242,0	0,19	82,78	83,67	82,02	0,18	83,89	84,38	83,04
276,0	442,0	0,8	0,8	5,7	280,8	77,0	92,5	517,5	523,7	414,4	454,2	241,7	0,19	83,01	83,72	81,99	0,18	83,97	84,40	83,02
277,0	443,0	0,8	0,8	5,7	279,6	76,9	94,0	516,5	522,9	414,1	453,2	241,8	0,19	83,18	83,78	81,96	0,18	84,08	84,43	83,01
278,0	444,0	0,8	0,8	5,7	278,7	76,5	95,4	515,6	522,2	413,5	452,6	241,5	0,19	83,48	83,87	81,99	0,18	84,26	84,49	83,06
279,0	445,0	0,7	0,8	5,7	278,1	76,8	96,4	514,5	521,5	413,1	451,9	241,1	0,19	83,76	83,98	82,01	0,18	84,47	84,57	83,09
280,0	446,0	0,7	0,8	5,7	277,2	77,2	97,2	513,4	520,7	411,9	451,1	240,8	0,19	84,08	84,10	82,03	0,18	84,69	84,65	83,13
281,0	447,0	0,7	0,8	5,7	276,1	77,1	98,0	512,1	520,1	411,5	450,4	240,2	0,19	84,35	84,20	82,05	0,18	84,92	84,76	83,16
282,0	448,0	0,7	0,8	5,8	275,7	76,8	97,4	510,9	519,4	411,1	449,4	240,4	0,19	84,60	84,32	82,10	0,18	85,17	84,87	83,19
283,0	449,0	0,7	0,8	5,7	276,0	76,9	96,4	509,9	518,6	410,6	448,7	240,1	0,19	84,79	84,41	82,13	0,18	85,32	84,96	83,22
284,0	450,0	0,6	0,8	5,7	275,6	76,8	95,5	508,8	517,9	409,8	447,9	240,2	0,19	84,84	84,44	82,14	0,18	85,43	84,99	83,22
285,0	451,0	0,6	0,8	5,7	275,2	77,0	94,6	507,8	517,2	409,4	446,8	240,3	0,19	84,84	84,50	82,15	0,18	85,48	85,03	83,20
286,0	452,0	0,6	0,8	5,7	275,2	76,8	94,2	506,8	516,4	408,7	445,9	240,0	0,19	84,78	84,50	82,18	0,18	85,47	85,07	83,23
287,0	453,0	0,6	0,8	5,7	275,3	77,0	93,8	505,9	515,6	408,1	445,2	239,7	0,19	84,70	84,51	82,21	0,18	85,50	85,08	83,23
288,0	454,0	0,6	0,8	5,7	275,0	77,4	93,6	505,2	514,8	407,4	444,5	239,3	0,19	84,64	84,51	82,23	0,18	85,49	85,09	83,23
289,0	455,0	0,6	0,8	5,7	274,9	77,4	93,2	504,3	514,0	406,7	443,9	239,1	0,19	84,56	84,48	82,23	0,18	85,43	85,10	83,20
290,0	456,0	0,6	0,8	5,7	275,2	77,2	92,8	503,7	513,1	406,2	442,9	239,0	0,19	84,50	84,45	82,24	0,18	85,39	85,09	83,19
291,0	457,0	0,6	0,8	5,7	274,9	77,2	92,6	503,2	512,2	405,6	442,3	238,7	0,19	84,41	84,44	82,26	0,18	85,32	85,09	83,17
292,0	458,0	0,5	0,7	5,5	274,1	76,6	92,1	502,4	511,3	405,6	441,5	238,8	0,19	84,26	84,40	82,29	0,18	85,20	85,07	83,15
293,0	459,0	0,5	0,7	5,3	273,3	76,8	92,1	501,3	510,6	404,5	440,7	238,8	0,19	84,17	84,39	82,31	0,18	85,18	85,04	83,18
294,0	460,0	0,5	0,7	5,2	273,0	77,3	92,0	500,3	509,7	404,3	439,9	238,4	0,19	84,02	84,36	82,33	0,19	85,11	85,04	83,17
295,0	461,0	0,5	0,7	5,3	272,6	76,9	91,6	499,1	508,9	403,7	439,4	237,9	0,19	83,95	84,34	82,32	0,18	85,06	85,01	83,14
296,0	462,0	0,5	0,6	5,3	271,8	76,8	91,3	498,2	508,0	403,0	438,3	237,2	0,19	83,86	84,32	82,32	0,18	84,99	85,01	83,14
297,0	463,0	0,4	0,6	5,3	271,2	76,7	91,6	497,2	507,3	402,5	437,4	237,1	0,19	83,84	84,33	82,28	0,18	84,95	85,00	83,12
298,0	464,0	0,4	0,6	5,3	270,7	77,3	91,7	496,1	506,5	402,1	436,7	237,0	0,19	83,83	84,32	82,26	0,18	84,94	85,00	83,07
299,0	465,0	0,4	0,6	5,3	270,3	77,2	91,6	495,0	505,7	401,3	435,8	237,0	0,19	83,75	84,29	82,25	0,18	84,90	84,98	83,09
300,0	466,0	0,4	0,6	5,3	270,1	76,3	91,3	494,0	504,9	400,7	434,9	237,1	0,19	83,68	84,25	82,26	0,18	84,77	84,94	83,08
301,0	467,0	0,4	0,6	5,3	269,7	76,9	91,2	493,0	504,1	400,1	434,2	236,8	0,19	83,68	84,24	82,24	0,18	84,77	84,92	83,07
302,0	468,0	0,4	0,6	5,2	269,3	77,1	91,4	491,9	503,3	399,6	433,0	236,3	0,19	83,59	84,22	82,23	0,18	84,73	84,90	83,06
303,0	469,0	0,4	0,6	5,2	269,2	76,9	91,2	491,0	502,5	398,7	432,5	235,9	0,19	83,62	84,22	82,23	0,18	84,72	84,90	83,05
304,0	470,0	0,3	0,6	5,2	269,0	77,0	91,1	490,2	501,7	398,1	431,7	235,7	0,19	83,59	84,20	82,23	0,18	84,71	84,90	83,02
305,0	471,0	0,4	0,6	5,2	268,4	77,3	91,4	489,1	500,9	397,4	431,0	235,5	0,19	83,59	84,16	82,20	0,18	84,64	84,86	83,00
306,0	472,0	0,3	0,6	5,2	267,8	76,9	90,9	488,1	500,1	396,8	429,8	235,1	0,19	83,58	84,13	82,16	0,18	84,59	84,83	82,96
307,0	473,0	0,3	0,6	5,2	267,5	76,9	90,9	487,2	499,4	396,4	429,1	234,9	0,19	83,50	84,10	82,13	0,18	84,51	84,80	82,94
308,0	474,0	0,3	0,6	5,2	266,9	76,7	90,7	486,3	498,6	395,7	428,1	234,4	0,19	83,50	84,10	82,13	0,18	84,53	84,81	82,92
309,0	475,0	0,3	0,6	5,1	266,8	76,8	90,7	485,2	497,7	395,2	427,6	234,4	0,19	83,51	84,06	82,12	0,18	84,55	84,80	82,89
310,0	476,0	0,2	0,6	5,1	266,6	77,0	90,6	484,3	496,9	394,4	426,8	234,2	0,19	83,49	84,03	82,08	0,18	84,52	84,78	82,87
311,0	477,0	0,2	0,6	5,1	265,8	76,8	90,6	483,3	496,2	394,1	426,0	234,0	0,19	83,44	84,02	82,07	0,18	84,48	84,77	82,84
312,0	478,0	0,2	0,6	5,1	265,6	76,8	90,4	482,1	495,3	393,7	425,1	233,8	0,19	83,39	83,99	82,06	0,18	84,43	84,76	82,81
313,0	479,0	0,2	0,6	5,1	264,8	77,0	91,4	481,1	494,6	392,8	424,3	232,8	0,19	83,49	84,01	82,02	0,18	84,49	84,75	82

Manufacturer: WOLFSTEEL  
 Model: EPI-3

Run: 2  
 Project #: PI-20190  
 Test Duration: 327 min

	HHV	LHV
Eff	71,95%	77,42%
Comb Eff	96,10%	96,10%
HT Eff	74,87%	80,56%
Output	21 197	kJ/h
Burn Rate	1,46	kg/h
Grams CO	458	g
Input	29 461	kJ/h
MC wet	18,86	

Note: In the "Input data", "Calc. % O<sub>2</sub>", "Fuel Properties", and "Mass Balance" columns, [e], [d], [g], [a], [b], [c], [h], [u], [w], [j], and [k] refer to their respective variables in Clauses 13.7.3

Ultimate CO<sub>2</sub>  
 CO<sub>2-ut</sub> 19,86  
 F<sub>o</sub>  
 1,050

	Air Fuel Ratio (A/F)	
Overall Heating Efficiency:	71,95%	Dry Molecular Weight (M <sub>d</sub> ) 29,91
Combustion Efficiency:	96,10%	Dry Moles Exhaust Gas (N <sub>g</sub> ): 400,49
Heat Transfer Efficiency:	74,87%	Air Fuel Ratio (A/F) 11,47

Heat Output:	20 108 Btu/h	21 197 kJ/h
Heat Input:	27 947 Btu/h	29 461 kJ/h
Burn Duration:	5,45 h	
Burn Rate:	3,21 lb/h	1,458 kg/h
Stack Temp:	376,9 Deg. F	191,6 Deg. C

Date: 2019-04-03 Manufacturer: WOLFSTEEL Model: EPI-3  
 Project #: PE-20190 Run: 2 Tech: S.B. Reviewer: SP

- Kindling 8.4 lbs, started fire (HALF/HALF MIN)
- CLOSED DOOR IMMEDIATELY
- At 2.7 lbs, inserted Hi LOAD.
- CLOSED DOOR IMMEDIATELY
- AFTER 10 MIN, STARTED FAN @ MED SPEED
- At 4.3 lbs, Stop pump AND FAN
- At 3.9 lbs, inserted MED LOAD, CLOSED DOOR IMMEDIATELY
- At 13 min, closed air inlet by 1/2
- At 14 min " " " " " " " " + 1/4
- At 15 min " " " " " " " " to final position (gap 2 1/8)
- NO FAN.

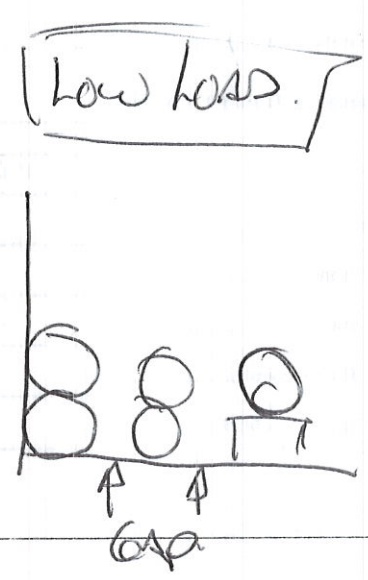
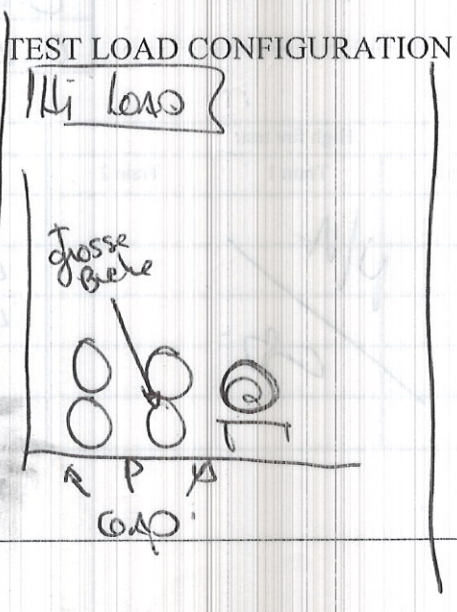
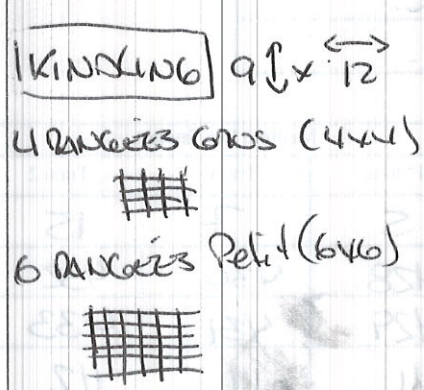

**PRE / POST CHECKS**

Date: 2019-04-03 Manufacturer: Wolf Steel Model: EDI-3  
 Project #: PT-20190 Run: 2 Tech: SAB Reviewer: JS

Moisture Meter Calibration Check:

Equipment #	Time	12%	22%
EM-191	7:00	✓	✓

Pre-Test

Post-Test

**Facility Conditions:**

Air Velocity from less than 2 feet .....  
 Smoke Capture Check.....  
 Picture.....

Pre-Test	Post-Test
0 (max50 Fpm)	0 (max50 Fpm)
O.K.	O.K.
4 sides O.K.	✓

**Wood Heater Conditions:**

Date Wood Heater Stack Cleaned.....  
 Date Dilution Tunnel Cleaned.....  
 Induced Draft Check (max 0.005 H2O).....  
 Traverse before ignition.....

2019-04-01
2019-04-01
O.K.
O.K.

**Temperature System:**

Ambient (65°-90°F).....

80.06 °F

**Proportional Checks:**

Thermocouple check.....  
 Pitot Clean.....  
 Pitot verification.....

O.K.
O.K.
O.K.

**Sampling Train ID Numbers:**

Probe.....  
 Filter Front.....  
 Filter Back.....  
 Filter Thermocouple.....  
 Filter (80°F ≥ <90°F).....

	High fire test			Medium low fire test		
	1 <sup>st</sup> hour	Train 1	Train 2	1 <sup>st</sup> hour	Train 1	Train 2
Probe				5	7	15
Filter Front				428	430	432
Filter Back				429	431	433
Filter Thermocouple				111	111	112
Filter (80°F ≥ <90°F)				✓	✓	✓

**SAMPLING EQUIPMENT CHECK OUT**

 Date: 2019-04-03 Manufacturer: WOLF STEEL Model: EPI-3  
 Project #: PT-20190 Run: 2 Tech: S.B Reviewer: JS
**Leakage Checks Tunnel Samplers**

High fire test	System 1 <sup>st</sup> hour		System 1		System 2	
	Pre-Test ASTM (-15) CSA B415 (-5)	Post-Test (max test)	Pre-Test ASTM (-15) CSA B415 (-5)	Post-Test (Max test)	Pre-Test ASTM (-15) CSA B415 (-5)	Post-Test (Max test)
Unplugged Flow Rate = .25cfm						
Vacuum (inches Hg.)	N/A					
Final 1minute DGM (Liter)	S.B					
Initial 1minute DGM (Liter)						
Change © (Liter)						
Allowable leakage .04 x Sample rate or 0.28Lpm CSA B415 ( 0.56)						
Check OK						

Low medium fire test	System 1 <sup>st</sup> hour		System 1		System 2	
	Pre-Test ASTM (-15) CSA B415 (-5)	Post-Test (max test)	Pre-Test ASTM (-15) CSA B415 (-5)	Post-Test (Max test)	Pre-Test ASTM (-15) CSA B415 (-5)	Post-Test (Max test)
Unplugged Flow Rate = .25cfm						
Vacuum (inches Hg.)	-15	-15	-15	-15	-15	-15
Final 1minute DGM (Liter)	886070.64	887955.43	886070.78	887955.64	835870.78	837733.33
Initial 1minute DGM (Liter)	886070.55	887955.38	886070.75	887955.56	835870.78	837733.30
Change © (Liter)	0.09	0.05	0.03	0.06	0	0.03
Allowable leakage .04 x Sample rate or 0.28Lpm CSA B415 ( 0.56)						
Check OK	✓	✓	✓	✓	✓	✓



### SAMPLING EQUIPMENT CHECK OUT

Date: 2019-04-03 Manufacturer: WOLF STEEL Model: EPI-3  
 Project #: SI-20190 Run: 2 Tech: S.B. Reviewer: Bl

#### Leakage Checks Flue Gas Sampler

Plugged Probe	Pre-Test	Post Test
Vacuum (inches Hg.)	-5	-5
Rotameter Reading (mml/min.)	0	0
Flow Rate (lpm)	1.5	1.5
Allowable (.02 x Sample Rate)	30	30
Check OK	✓	✓

#### Leakage Checks Pitot

Plugged Probe	Pre Test 3 H <sub>2</sub> O static	Pre Test 0.4-0.5 H <sub>2</sub> O velocity	Post Test 3 H <sub>2</sub> O Static	Post Test 0.4-0.5 H <sub>2</sub> O velocity
Vacuum (inches Hg.)	3.064	0.4451	3.022	0.4731
Check OK (no change after 15 sec.)	O.K.	O.K.	O.K.	O.K.



Date: 2019-04-03 Manufacturer: WOLFSTEEL Model: EPI-3  
 Project #: PI-20190 Run: 2 Tech: S.B Reviewer: JP

Scale Type	Audit		Measured Weight
	Equipment #	Weight	
Platform	EM-090	4.4 lbs, Class F	4.4 lbs
Wood	EM-090	4.4 lbs, Class F	4.4 lbs
Analytical	EM-128	100 mg, Class S	100 mg
Analytical	EM-129	200 g, Class S	200 g

**LIMITS OF WEIGHT RANGES**

**ANALYTICAL SCALE:** ..... 50%-150% of dry filter weight, ± 0.1 mg  
**PLATFORM SCALE:** ..... 20%-80% of ideal test load weight, ± 0.1 lbs or 1%  
**WOOD SCALE:** ..... 20%-80% of ideal test load weight, ± 0.01 lbs or 1%

Date: 2019-04-03 Manufacturer: WOLF STEEL Model: EPT-3  
 Project #: PI-2010 Run: Z Tech: S.B. Reviewer: DP

FOR TUNNELS &lt; 12 in

 Barometric pressure ( $P_{bar}$ ) 101.4 (KPa.) Static pressure ( $P_q$ ) 0.171 (inches w.c.)  
 Inside diameter: Port A 8 Port B 8  
 Tunnel cross sectional area: .1963Ft<sup>2</sup>  
 Pitot tube type: Standard

Traverse Point	Position (inches)			Velocity Head $\Delta_p$ (inches H <sub>2</sub> O)	Tunnel Temperature (°F)
	6 po	7 po	8 po		
A- Centroid	3.00	3.50	4	0.054	78.10
B - Centroid	3.00	3.50	4	0.055	78.50
A-1	0.40	0.50	0.50	0.052	78.61
A-2	1.50	1.75	2	0.061	78.60
A-3	4.50	5.25	6	0.067	78.72
A-4	5.60	6.5	7.5	0.066	78.20
B-1	0.40	0.50	0.50	0.052	78.73
B-2	1.50	1.75	2	0.063	78.74
B-3	4.50	5.25	6	0.047	78.78
B-4	5.60	6.5	7.5	0.041	78.01
AVERAGE					78.50

$$v_s = K_p C_p (\sqrt{\Delta p})_{avg} \sqrt{\frac{(T_s)_{avg}}{P_s M_s}}$$

Where,

 $C_p$  = pitot tube coefficient, dimension less = 0.99 for standard pitot.

 $\Delta_p$  = manometer reading (inches H<sub>2</sub>O)

 $T_s$  = average absolute dilution tunnel temperature (°F + 460)

 $P_s$  = absolute dilution tunnel gas pressure or  $P_{bar} - P_{qg}$ 
 $P_q$  = static pressure in. H<sub>2</sub>O  
 { 13.6 }

 $M_s$  = 28.56, wet molecular weight of stack gas (alternatively, it may be measured)

 $K_p$  = 85.49 pitot tube constant, (conversion factor for English units)

 $\Delta_p$ avg. = average of the square roots of the velocity heads ( $\Delta_p$ ) measured at each traverse point.

Date: 2019-04-03 Manufacturer: WOLFSTEEL Model: EPI-3  
 Project #: 01-20190 Run: 2 Tech: S.B. Reviewer: DS

**Pre-Test (Adjust and Record)**

	ZERO		SPAN		CAL. (Record Only)	
	Actual	Should Be	Actual	Should Be	Actual	Should Be
CO	0.003	0	2.990	3.00	1.009	1.000
Tolerance CO		+/- 0.02		+/- 0.15		+/- 0.05
CO <sub>2</sub>	0	0	17.95	18.00	9.77	10.00
Tolerance CO <sub>2</sub>		+/- 0.02		+/- 0.5		+/- 0.5
O <sub>2</sub> informative CSA B415 calculated value	na	na	na	na	na	na
	Actual	Should Be	Actual	Should Be	Actual	Should Be

**Post Test (Record Only)**

	Zero	Span	Cal.	Zero Drift	Limit	Span Drift	Limit	Cal. Drift	Limit	OK?	Not OK*
CO	0	2.991	1.009	0	0.02	0.001	0.15	0	0.05	✓	
CO <sub>2</sub>	0	17.94	9.88	0	0.02	0.01	0.5	0.11	0.5	✓	

**TEST DATA LOG**

 Date: 2019-04-03 Manufacturer: WOLF STEEL Model: EPT-3  
 Project #: PI-20190 Run: 2 Tech: S.B. Reviewer: SB
**RAW DRY GAS METER READINGS**

		System 1	System 2	Blank
High fire test	Final (Liter)	N/A		
	Initial (Liter)	N/A		
Low medium fire test	Final (Liter)	887 954.35	837 732.30	026.91
	Initial (Liter)	886 070.70	835 871.51	944.90

**AMBIENT CONDITIONS**

	Before	After
Barometer (kPa):	101.4	100.5
Dry Bulb (F):	<del>71</del> 68.54	80.06
Humidity (%):	24.3	26.6

## FUEL DATA

Date: 2019-04-03 Manufacturer: WOLF STEEL Model: EPC 3  
 Project #: QT-201901 Run: 2 Tech: S.B. Reviewer: [Signature]

### FUEL DESCRIPTION:

Type of wood:

### KINDLING AND START-UP LOAD

Piece Size	Weight	Meter Moisture Content (% dry)			
x x in.	3.4 lbs.	9		9	9
x x in.	5 lbs.	20		20	20
x x in.	lbs.				
x x in.	lbs.				
x x in.	lbs.				
x x in.	lbs.				
x x in.	lbs.				
x x in.	lbs.				
x x in.	lbs.				

### HIGHFIRE TEST LOAD

Piece Size	Weight	Meter Moisture Content (% dry)			
3.25 x 3 x 16 in.	3.588 lbs.	26.3		18.3	25.3
3.25 x 3 x 16 in.	3.500 lbs.	18.1		18.4	20.4
3 x 3 x 16 in.	3.594 lbs.	22.3		26.8	26.4
3.5 x 3.75 x 16 in.	5.040 lbs.	18.3		18.4	18.4
2.75 x 2.5 x 16 in.	2.066 lbs.	21.7		19.4	24.2
x x in.	lbs.				
x x in.	lbs.				
x x in.	lbs.				
x x in.	lbs.				

### FUEL DATA

Date: 2019-04-03 Manufacturer: WOLF STEEL Model: EPI-3  
 Project #: PI-20190 Run: 2 Tech: S.B. Reviewer: SP

**FUEL DESCRIPTION:**

Type of wood:

**LOW OR MEDIUM TEST LOAD**

Piece Size	Weight	Meter Moisture Content (% dry)			
4 x 3 x 16 in.	4.320 lbs.	18.3		18.6	18.7
4.5 x 2.75 x 16 in.	4.620 lbs.	20.3		18.9	19.4
4 x 3 x 16 in.	4.458 lbs.	27.6		19.8	27.3
4.5 x 3 x 16 in.	5.110 lbs.	28.4		28.7	24.1
2.5 x 3.5 x 16 in.	3.074 lbs.	27.8		18.9	25.9
x x in.	lbs.				
x x in.	lbs.				
x x in.	lbs.				
x x in.	lbs.				
x x in.	lbs.				
x x in.	lbs.				
x x in.	lbs.				
x x in.	lbs.				
x x in.	lbs.				







Date: 2019-04-02 Run: 2 Manufacturer: WooFSteel Model: LPJ-3  
 Project #: PI 20190 Tech: MA Reviewer: SP

**LOW OR MEDIUM TEST FILTERS**

Pre-test Weight Record		SYSTEM 1 - 1 <sup>st</sup> hour							SYSTEM 1	
Date	Time	Probe & Housing Number	Front Filter Number	Back Filter Number	gaskets	Probe & Housing Number	Front Filter Number	Back Filter Number	gaskets	Blauck
2019.04.02	14:00	614759	00875	00858	33 7895	108 7838	00869	00852	34 8758	00838
2019.04.03	7:00	614759	00875	00858	33 7895	108 7838	00869	00852	34 8758	00838

**LOW OR MEDIUM TEST FILTERS**

Post-test Weight Record		SYSTEM 1 - 1 <sup>st</sup> hour							SYSTEM 1	
Date	Time	Probe & Housing Number	Front Filter Number	Back Filter Number	gaskets	Probe & Housing Number	Front Filter Number	Back Filter Number	gaskets	Blauck
2019.04.03	16:30	614759	00882	00863	33 7907	108 7838	00875	00854	34 8766	00844
2019.04.10	11:00	614759	00882	00859	33 7897	108 7838	00875	00853	34 8765	00840
2019.04.15	8:00	614759	00882	00859	33 7896	108 7838	00875	00853	34 8764	00840



# DILUTION TUNNEL PARTICULATE SAMPLER DATA

Date: 2019.03.02      Manufacturer: Wolfsberg      Model: EPI-3  
 Project #: PT 20190      Run: 2      Tech: MM      Reviewer: SP

LOW OR MEDIUM FIRE TEST FILTERS				
SYSTEM 2				
Pre-test Weight Record	Probe & Housing Number	Front Filter Number	Back Filter Number	gaskets
	5	428	429	8
2019-04-02 14:00	615040	00875	00855	35 7068
2019-04-03 7:00	615040	00875	00855	35 7068

LOW OR MEDIUM FIRE TEST FILTERS				
SYSTEM 2				
Post-test Weight Record	Probe & Housing Number	Front Filter Number	Back Filter Number	gaskets
	5	428	429	8
2019-04-03 16:30	615042	00890	00859	35 7075
2019-04-10 14:00	615041	00887	00856	35 7071
2019-04-15 8:00	615042	00887	00856	35 7072

## APPENDIX 2: Proportionality results

Average	Average	Average	Proportional	Highfire				Average
16,19	Inlet +	Inlet +						0,236
	Outlet	Outlet	Average	Average	#1	#2		
Tunnel	Temp.	Temp.	98,28	100,55	System 1	System 2		SQRT
Velocity	Meter 1	Meter 2	Proportional Rates		Vol.Std.	Vol.Std.		Delta-P
			PR1	PR2			Time	
Ft/Sec	Deg. R	Deg. R	%	%	(ft3)	(ft3)	min	(in H2O)2
15,481	531,8	532,0			0,180	0,158	0	0,2356195
15,973	532,0	532,2	93,29	95,20	0,187	0,171	1	0,24216
15,626	532,0	532,3	95,33	97,39	0,193	0,184	2	0,2367177
15,610	532,0	532,3	96,53	98,61	0,193	0,184	3	0,2351826
15,844	532,0	532,3	97,06	99,08	0,193	0,184	4	0,2362697
16,059	532,1	532,4	96,98	99,29	0,193	0,184	5	0,2377995
16,048	532,2	532,4	98,05	100,35	0,193	0,184	6	0,2362707
16,308	532,3	532,5	98,22	100,60	0,193	0,185	7	0,2382161
16,200	532,4	532,6	99,52	101,85	0,193	0,185	8	0,2356196
16,468	532,5	532,7	98,22	100,62	0,193	0,184	9	0,2392843
15,980	532,7	532,8	100,55	102,64	0,193	0,184	10	0,2329706
16,031	532,7	532,9	99,60	102,12	0,193	0,184	11	0,2342492
16,197	532,8	533,0	98,73	100,89	0,193	0,184	12	0,2367036
16,141	532,9	533,1	99,36	101,42	0,193	0,184	13	0,235617
15,876	532,9	533,2	101,18	103,49	0,193	0,184	14	0,2314663
16,138	533,1	533,3	99,56	101,79	0,193	0,184	15	0,2351717
16,104	533,1	533,3	99,92	102,16	0,193	0,184	16	0,2345262
16,184	533,2	533,4	99,45	101,60	0,193	0,184	17	0,2356176
16,095	533,3	533,5	100,01	102,40	0,193	0,184	18	0,234226
16,079	533,4	533,6	100,06	102,16	0,193	0,184	19	0,2340875
15,985	533,4	533,7	100,39	102,53	0,193	0,184	20	0,2329921
16,052	533,5	533,8	100,06	102,24	0,193	0,184	21	0,2340898
16,508	533,6	533,8	96,86	99,52	0,193	0,184	22	0,240785
16,069	533,6	533,9	99,59	101,79	0,192	0,184	23	0,2345276
16,037	533,7	534,0	99,69	102,02	0,193	0,184	24	0,2340919
16,029	533,7	534,1	99,56	101,99	0,192	0,184	25	0,2341692
15,840	533,7	534,1	100,71	103,05	0,192	0,184	26	0,2314472
15,908	533,8	534,2	100,12	102,42	0,192	0,184	27	0,2326955
16,006	533,8	534,2	99,54	101,90	0,193	0,184	28	0,2340901
16,107	533,8	534,2	98,87	101,19	0,193	0,184	29	0,2356108
16,340	533,9	534,2	100,21	102,63	0,192	0,184	30	0,235685
16,286	534,0	534,3	98,20	100,29	0,193	0,184	31	0,2377861
16,231	534,0	534,4	98,14	100,58	0,192	0,184	32	0,237225
16,214	534,1	534,5	98,13	100,40	0,192	0,184	33	0,2371371
15,987	534,1	534,5	99,24	101,48	0,192	0,184	34	0,234092
16,103	534,1	534,6	98,85	101,12	0,192	0,184	35	0,2356201
16,028	534,4	534,7	99,77	102,26	0,192	0,184	36	0,233655
16,266	534,7	534,9	98,58	101,03	0,192	0,184	37	0,2367056
16,380	535,0	535,1	98,25	100,52	0,192	0,183	38	0,2378535
16,363	535,4	535,4	98,69	100,87	0,192	0,183	39	0,2371387
16,145	535,7	535,6	100,40	102,69	0,192	0,183	40	0,2336539
16,305	536,1	535,9	99,58	101,73	0,192	0,183	41	0,2355949
16,649	536,5	536,2	97,52	99,90	0,191	0,183	42	0,240361
16,253	536,8	536,5	100,24	102,38	0,191	0,183	43	0,2345306
16,431	537,1	536,8	98,89	101,17	0,191	0,183	44	0,2371097
16,422	537,3	537,0	98,85	101,26	0,191	0,183	45	0,2371391
16,386	537,5	537,2	99,00	101,17	0,191	0,183	46	0,2367076
16,349	537,5	537,3	99,12	101,50	0,191	0,183	47	0,2362719
16,368	537,5	537,4	98,65	101,37	0,191	0,183	48	0,2367064
16,357	537,5	537,5	99,01	101,12	0,191	0,183	49	0,2367126
16,320	537,4	537,5	98,90	101,30	0,191	0,183	50	0,2362729
16,533	537,4	537,5	97,66	100,04	0,191	0,183	51	0,2392926
16,191	537,5	537,6	99,69	102,04	0,191	0,183	52	0,2345372
16,427	537,5	537,6	98,06	100,24	0,191	0,183	53	0,2382148
16,294	537,5	537,6	98,67	101,05	0,191	0,183	54	0,2362728
16,130	537,3	537,5	99,63	102,38	0,191	0,183	55	0,2339289
16,395	537,3	537,4	98,19	100,68	0,191	0,183	56	0,2377655
16,158	537,3	537,5	99,55	101,82	0,191	0,183	57	0,234441
16,191	537,4	537,5	99,18	101,70	0,191	0,183	58	0,2349907
16,115	537,4	537,5	99,43	102,10	0,191	0,183	59	0,2340962
16,262	537,4	537,5	98,65	101,11	0,191	0,183	60	0,2362723
16,375	537,3	537,4	97,78	100,08	0,191	0,183	61	0,2381563
16,128	537,2	537,4	99,26	101,72	0,191	0,183	62	0,2345279
16,304	537,3	537,4	98,23	100,57	0,191	0,183	63	0,2371386
16,160	537,3	537,4	99,06	101,27	0,191	0,183	64	0,2349845
16,111	537,3	537,4	99,49	101,80	0,191	0,183	65	0,2340937
16,133	537,2	537,4	99,42	101,61	0,191	0,183	66	0,2345302
16,311	537,2	537,4	98,27	100,62	0,191	0,183	67	0,2371396
16,452	537,3	537,5	97,39	99,52	0,191	0,183	68	0,2392932
16,190	537,4	537,6	98,64	100,96	0,191	0,183	69	0,2356227
16,345	537,5	537,6	97,84	99,98	0,191	0,183	70	0,2377881
16,590	537,5	537,6	96,39	98,68	0,191	0,183	71	0,2412149
16,352	537,6	537,7	97,67	99,98	0,191	0,183	72	0,2378465
16,522	537,6	537,7	96,75	99,11	0,191	0,183	73	0,2403628
16,293	537,7	537,8	97,96	100,13	0,191	0,183	74	0,2371434
16,304	537,7	537,8	97,71	100,04	0,191	0,182	75	0,2373503

16,533	537,6	537,8	96,32	98,67	0,191	0,183	76	0,2407982
17,072	537,6	537,8	93,36	95,51	0,191	0,183	77	0,2487519
16,675	537,6	537,8	95,66	97,85	0,191	0,183	78	0,2429111
16,554	537,7	537,9	96,23	98,44	0,191	0,183	79	0,2412136
16,518	537,8	538,0	96,42	98,61	0,191	0,183	80	0,2407034
16,557	537,8	538,0	96,06	98,40	0,191	0,183	81	0,2412186
16,344	537,8	538,0	97,41	99,74	0,191	0,183	82	0,2382238
16,554	537,9	538,0	96,25	98,58	0,191	0,183	83	0,2412192
16,153	538,0	538,1	98,39	100,65	0,191	0,183	84	0,2356285
16,417	538,0	538,2	97,02	98,98	0,191	0,182	85	0,2392996
16,304	538,1	538,3	97,40	99,56	0,191	0,182	86	0,2377948
16,049	538,2	538,4	98,60	101,18	0,191	0,182	87	0,2342206
16,433	538,3	538,4	96,47	98,76	0,191	0,182	88	0,2397151
16,140	538,2	538,4	98,19	100,33	0,191	0,182	89	0,2356195
16,596	538,2	538,4	95,58	97,63	0,191	0,182	90	0,24216
16,222	538,3	538,5	97,62	99,94	0,191	0,182	91	0,2367177
16,119	538,4	538,6	98,47	100,77	0,191	0,182	92	0,2351826
16,191	538,4	538,6	97,77	100,17	0,191	0,182	93	0,2362697
16,289	538,4	538,6	97,23	99,34	0,191	0,182	94	0,2377995
16,194	538,4	538,6	98,08	100,29	0,191	0,182	95	0,2362707
16,310	538,4	538,6	96,92	99,10	0,191	0,182	96	0,2382161
16,143	538,5	538,6	98,09	100,43	0,191	0,182	97	0,2356196
16,384	538,5	538,6	96,67	98,69	0,191	0,182	98	0,2392843
15,958	538,4	538,6	99,15	101,38	0,191	0,182	99	0,2329706
16,042	538,4	538,7	98,58	100,87	0,191	0,182	100	0,2342492
16,209	538,4	538,7	97,64	99,71	0,191	0,182	101	0,2367036
16,129	538,4	538,6	98,02	100,53	0,191	0,182	102	0,235617
15,854	538,3	538,6	100,04	102,01	0,191	0,182	103	0,2314663
16,098	538,2	538,6	98,33	100,60	0,191	0,182	104	0,2351717
16,063	538,2	538,6	98,62	101,03	0,191	0,183	105	0,2345262
16,131	538,3	538,7	98,16	100,24	0,191	0,182	106	0,2356176
16,034	538,3	538,7	98,63	100,83	0,191	0,182	107	0,234226
16,014	538,4	538,7	98,54	100,91	0,191	0,182	108	0,2340875
15,936	538,4	538,8	99,08	101,32	0,191	0,182	109	0,2329921
16,005	538,4	538,8	98,67	100,94	0,191	0,182	110	0,2340898
16,456	538,4	538,9	95,80	98,10	0,191	0,182	111	0,240785
16,009	538,4	538,8	98,31	100,56	0,191	0,182	112	0,2345276
15,987	538,3	538,8	98,67	100,75	0,191	0,182	113	0,2340919
15,982	538,4	538,9	98,59	100,65	0,191	0,182	114	0,2341692
15,801	538,4	538,9	99,67	101,98	0,191	0,182	115	0,2314472
15,881	538,5	539,0	99,04	101,29	0,191	0,182	116	0,2326955
15,970	538,6	539,0	98,28	100,76	0,191	0,182	117	0,2340901
16,071	538,6	539,0	97,69	99,91	0,191	0,182	118	0,2356108
16,060	538,6	539,0	97,69	99,76	0,191	0,182	119	0,235685
16,199	538,5	539,0	96,76	99,00	0,191	0,182	120	0,2377861
16,160	538,5	539,0	96,85	99,12	0,191	0,182	121	0,237225
16,150	538,5	539,0	96,87	99,14	0,191	0,182	122	0,2371371
15,933	538,4	538,9	98,41	100,50	0,191	0,182	123	0,234092
16,031	538,4	538,9	97,66	99,76	0,191	0,182	124	0,2356201
15,887	538,4	538,9	98,22	100,68	0,191	0,183	125	0,233655
16,078	538,5	539,0	96,87	99,16	0,191	0,183	126	0,2367056
16,153	538,5	539,0	96,33	98,50	0,191	0,182	127	0,2378535

Average	Average	Average	Proportional Rates Medium/low fire				Average
16,20	Inlet +	Inlet +					0,242
	Outlet	Outlet	Average	Average	#1	#2	
Tunnel	Temp.	Temp.	98,50	101,28	System 1	System 2	SQRT
Velocity	Meter 1	Meter 2	Proportional Rates		Vol.Std.	Vol.Std.	Delta-P
			PR1	PR2			Time
Ft/Sec	Deg. R	Deg. R	%	%	(ft3)	(ft3)	min (in H2O)2
16,293	537,8	538,5			0,191	0,183	0 0,2392926
15,908	537,8	538,6	103,58	106,47	0,191	0,182	1 0,2345372
16,173	537,9	538,7	102,06	104,81	0,191	0,182	2 0,2382148
16,114	537,9	538,6	103,42	106,26	0,191	0,182	3 0,2362728
16,020	537,9	538,7	104,87	107,88	0,191	0,182	4 0,2339289
16,336	537,9	538,7	103,54	106,40	0,191	0,182	5 0,2377655
16,158	538,0	538,7	105,26	108,44	0,191	0,182	6 0,2344441
16,247	538,2	538,8	105,38	108,51	0,191	0,183	7 0,2349907
16,230	538,3	538,9	106,03	108,84	0,191	0,182	8 0,2340962
16,398	538,4	539,0	105,09	108,35	0,191	0,182	9 0,2362723
16,531	538,5	539,0	104,17	107,20	0,190	0,182	10 0,2381563
16,280	538,5	539,1	105,89	109,21	0,190	0,182	11 0,2345279
16,433	538,7	539,2	104,56	107,61	0,191	0,182	12 0,2371386
16,185	538,8	539,3	105,02	108,13	0,191	0,182	13 0,2349845
16,011	538,9	539,4	104,53	107,48	0,191	0,182	14 0,2340937
15,948	538,9	539,4	103,78	106,65	0,191	0,182	15 0,2345302
16,085	539,0	539,5	102,41	105,25	0,191	0,182	16 0,2371396
16,217	539,2	539,6	101,24	104,31	0,191	0,182	17 0,2392932
15,965	539,5	539,8	102,79	105,93	0,190	0,182	18 0,2356227
16,118	539,8	540,0	101,82	105,06	0,190	0,182	19 0,2377881
16,347	540,1	540,2	100,30	103,20	0,190	0,182	20 0,2412149
16,117	540,3	540,4	101,69	104,69	0,190	0,182	21 0,2378465
16,282	540,5	540,6	100,54	103,61	0,190	0,182	22 0,2403628
16,072	540,7	540,8	101,75	105,06	0,190	0,182	23 0,2371434
16,090	540,9	541,0	101,72	104,57	0,190	0,182	24 0,2373503
16,328	541,1	541,2	100,32	103,44	0,190	0,181	25 0,2407982
16,861	541,3	541,4	97,16	99,80	0,190	0,181	26 0,2487519
16,468	541,6	541,6	99,28	102,48	0,190	0,181	27 0,2429111
16,350	541,8	541,8	100,03	102,93	0,189	0,181	28 0,2412136
16,316	542,0	542,0	100,04	103,10	0,189	0,181	29 0,2407034
16,337	542,1	542,2	99,71	102,54	0,189	0,181	30 0,2412186
16,112	542,2	542,3	100,63	103,63	0,189	0,181	31 0,2382238
16,300	542,3	542,4	99,45	102,33	0,189	0,181	32 0,2412192
15,908	542,2	542,5	101,64	104,41	0,189	0,181	33 0,2356285
16,152	542,1	542,5	99,98	102,99	0,189	0,181	34 0,2392996
16,042	542,0	542,4	100,59	103,38	0,189	0,181	35 0,2377948
16,272	541,9	542,3	99,31	101,95	0,189	0,180	36 0,2412748
16,033	541,7	542,3	100,64	103,37	0,189	0,180	37 0,2378161
16,326	541,6	542,2	98,76	101,51	0,189	0,181	38 0,2422808
16,150	541,5	542,1	99,74	102,73	0,189	0,181	39 0,2397282
16,117	541,4	542,1	99,82	102,58	0,189	0,181	40 0,2393056
16,307	541,4	542,1	98,63	101,40	0,189	0,180	41 0,2422825
16,012	541,3	542,0	100,55	103,38	0,189	0,181	42 0,2377943
15,898	541,3	542,0	101,09	103,99	0,189	0,181	43 0,236281
15,942	541,3	542,0	100,82	103,83	0,189	0,181	44 0,2368814
16,177	541,3	542,0	99,43	102,12	0,189	0,181	45 0,240377
16,031	541,3	542,0	100,26	103,18	0,189	0,181	46 0,2382848
16,041	541,4	542,0	100,50	103,06	0,189	0,181	47 0,2382274
16,166	541,7	542,1	99,98	102,82	0,189	0,181	48 0,2397285
16,318	541,8	542,2	99,11	102,04	0,189	0,181	49 0,2417591
16,363	542,0	542,4	98,98	101,76	0,189	0,181	50 0,2422831
16,199	542,3	542,5	100,03	102,97	0,189	0,181	51 0,2397286
16,205	542,5	542,7	99,88	102,88	0,189	0,181	52 0,2397278
16,376	542,7	542,9	99,01	101,69	0,189	0,180	53 0,2422808
16,223	542,8	543,0	99,55	102,53	0,189	0,180	54 0,2402663
16,175	542,8	543,1	99,79	102,67	0,189	0,181	55 0,2397298
16,331	542,7	543,1	98,65	101,56	0,189	0,181	56 0,2422827
16,125	542,7	543,1	99,93	102,67	0,189	0,181	57 0,2393074
16,362	542,6	543,0	98,60	101,16	0,189	0,180	58 0,2429178
16,282	542,5	543,0	98,79	101,48	0,189	0,180	59 0,24186
16,031	542,4	542,9	100,23	103,10	0,189	0,181	60 0,2382223
16,171	542,3	542,9	99,22	102,30	0,189	0,181	61 0,2403725
16,361	542,2	542,8	98,01	100,77	0,189	0,181	62 0,2433398
16,184	542,1	542,7	99,11	101,82	0,189	0,181	63 0,2407987
16,118	542,0	542,7	99,50	102,32	0,189	0,181	64 0,2397301
16,329	542,0	542,6	98,18	100,97	0,189	0,181	65 0,2429174
16,257	541,9	542,6	98,53	101,38	0,189	0,181	66 0,2418609
16,109	541,9	542,6	99,52	102,22	0,189	0,180	67 0,239705
16,185	541,9	542,5	99,11	102,02	0,189	0,181	68 0,2407981
15,886	541,9	542,5	100,84	103,53	0,189	0,180	69 0,2362966

16,104	541,8	542,5	99,71	102,25	0,189	0,180	70	0,2394899
16,262	541,8	542,5	98,73	101,50	0,189	0,180	71	0,2418605
15,949	541,8	542,5	100,59	103,39	0,189	0,181	72	0,2371508
15,992	541,8	542,4	100,29	103,10	0,189	0,180	73	0,2377964
15,917	541,7	542,4	100,81	103,32	0,189	0,180	74	0,2367115
15,812	541,7	542,4	101,41	104,34	0,189	0,180	75	0,2351945
16,010	541,7	542,4	100,09	103,08	0,189	0,181	76	0,2382276
15,886	541,7	542,4	100,91	103,79	0,189	0,181	77	0,2362816
16,301	541,9	542,4	98,58	101,21	0,189	0,180	78	0,2422829
16,373	542,1	542,6	98,35	101,29	0,189	0,180	79	0,2429124
15,952	542,4	542,8	101,24	104,04	0,189	0,180	80	0,2363589
16,017	542,6	542,9	100,93	103,88	0,189	0,180	81	0,2371219
16,171	542,8	543,1	100,10	102,95	0,189	0,180	82	0,2392924
16,059	543,0	543,3	100,52	103,39	0,189	0,180	83	0,2377965
16,052	543,1	543,4	100,57	103,48	0,189	0,180	84	0,2377974
15,998	543,1	543,5	100,47	103,48	0,188	0,180	85	0,2371935
16,398	543,0	543,5	98,04	100,93	0,188	0,180	86	0,2433395
16,391	542,9	543,4	98,01	100,83	0,189	0,180	87	0,243342
15,941	542,9	543,4	100,83	103,77	0,189	0,180	88	0,2367175
16,130	542,9	543,4	99,61	102,50	0,189	0,181	89	0,239687
16,232	542,8	543,4	98,77	101,59	0,189	0,181	90	0,2413431
16,094	542,8	543,4	99,73	102,41	0,189	0,180	91	0,2393015
15,815	542,7	543,3	101,37	104,19	0,189	0,180	92	0,2351949
15,980	542,6	543,3	100,41	102,99	0,189	0,180	93	0,2376769
16,076	542,5	543,2	99,59	102,50	0,189	0,180	94	0,2393016
15,997	542,5	543,1	100,04	102,71	0,189	0,181	95	0,238227
16,275	542,4	543,1	98,26	101,05	0,189	0,180	96	0,2424061
15,922	542,3	543,0	100,33	103,17	0,189	0,180	97	0,2371681
16,158	542,2	542,9	98,90	101,60	0,189	0,180	98	0,2407955
16,182	542,1	542,8	98,66	101,54	0,189	0,181	99	0,2412217
16,619	542,1	542,8	96,00	98,94	0,189	0,181	100	0,2477234
16,292	542,0	542,7	98,11	100,67	0,189	0,181	101	0,242915
16,079	541,9	542,6	99,35	102,15	0,189	0,181	102	0,2397266
15,905	541,9	542,6	100,33	103,20	0,189	0,181	103	0,2371459
15,873	541,8	542,6	100,62	103,25	0,189	0,180	104	0,2367042
16,043	541,8	542,5	99,41	102,38	0,189	0,181	105	0,2392982
16,077	541,8	542,5	99,39	102,09	0,189	0,181	106	0,2397266
15,870	541,8	542,4	100,60	103,20	0,189	0,180	107	0,2367128
15,941	541,7	542,4	100,16	102,81	0,189	0,180	108	0,2377926
15,940	541,7	542,4	100,08	102,71	0,189	0,180	109	0,2377929
16,037	541,7	542,4	99,42	102,19	0,189	0,180	110	0,239298
16,143	541,6	542,4	98,83	101,67	0,189	0,181	111	0,2407931
15,962	541,6	542,3	99,84	102,58	0,189	0,181	112	0,2381695
16,055	541,6	542,3	99,26	101,83	0,189	0,180	113	0,239713
16,337	541,5	542,3	97,59	100,16	0,189	0,180	114	0,2437781
15,930	541,5	542,2	99,92	102,87	0,189	0,180	115	0,2377933
16,033	541,5	542,2	99,32	102,35	0,189	0,181	116	0,2392975
16,108	541,5	542,2	98,97	101,79	0,189	0,181	117	0,2404805
16,152	541,5	542,2	98,50	101,41	0,189	0,181	118	0,2412029
16,639	541,5	542,2	95,76	98,35	0,189	0,181	119	0,2484181
15,944	541,5	542,2	99,71	102,57	0,189	0,181	120	0,2382242
15,913	541,5	542,2	99,95	102,65	0,189	0,181	121	0,2377916
16,080	541,5	542,2	98,77	101,79	0,189	0,181	122	0,2403485
16,403	541,5	542,1	96,79	99,45	0,189	0,181	123	0,2452256
16,068	541,4	542,1	98,73	101,59	0,189	0,181	124	0,2403661
16,225	541,4	542,1	97,65	100,52	0,189	0,181	125	0,2428325
16,013	541,4	542,1	99,03	101,56	0,189	0,181	126	0,2397255
15,842	541,3	542,1	99,91	102,76	0,189	0,180	127	0,2371454
16,156	541,2	542,0	98,09	100,85	0,189	0,181	128	0,2418656
16,184	541,2	542,0	97,93	100,56	0,189	0,181	129	0,2422487
16,221	541,2	541,9	97,68	100,49	0,189	0,181	130	0,2429147
15,978	541,2	542,0	99,01	101,79	0,189	0,181	131	0,2392988
15,895	541,3	542,0	99,66	102,72	0,189	0,181	132	0,237795
16,114	541,6	542,2	98,53	101,25	0,189	0,181	133	0,2408335
16,110	541,9	542,3	98,89	101,73	0,189	0,180	134	0,2403662
16,322	542,1	542,5	97,72	100,52	0,189	0,180	135	0,2433372
16,222	542,3	542,7	98,39	101,18	0,189	0,180	136	0,2418543
16,137	542,4	542,8	98,58	101,38	0,189	0,180	137	0,2407948
16,024	542,4	542,9	99,13	101,97	0,189	0,180	138	0,2393
16,266	542,4	542,9	97,44	100,40	0,189	0,180	139	0,2430896
16,302	542,4	542,9	97,33	100,18	0,189	0,181	140	0,2437578
16,133	542,4	543,0	98,33	100,96	0,189	0,180	141	0,2412205
16,460	542,5	543,0	96,50	99,39	0,189	0,180	142	0,2458526
16,428	542,7	543,2	96,93	99,62	0,189	0,180	143	0,2451653
16,444	542,9	543,3	96,73	99,64	0,189	0,180	144	0,2451712
16,301	543,0	543,5	97,82	100,73	0,188	0,180	145	0,2429165
16,138	543,2	543,6	98,89	101,63	0,189	0,180	146	0,2403705
15,944	543,4	543,8	100,17	103,03	0,189	0,180	147	0,2374066

16,075	543,7	544,0	99,41	102,12	0,189	0,180	148	0,2393066
16,256	543,9	544,2	98,41	101,18	0,189	0,180	149	0,2418638
15,939	544,0	544,4	100,20	103,12	0,188	0,180	150	0,2371521
16,315	544,2	544,6	97,98	100,62	0,188	0,180	151	0,242676
16,250	544,4	544,8	98,29	100,96	0,188	0,180	152	0,2418627
16,230	544,5	544,9	98,50	101,33	0,189	0,180	153	0,2418619
16,371	544,4	544,9	97,34	100,12	0,189	0,181	154	0,2442093
16,156	544,4	544,8	98,57	101,23	0,189	0,180	155	0,2412215
16,049	544,2	544,8	99,28	101,84	0,189	0,180	156	0,2397325
16,876	544,1	544,7	94,15	96,79	0,189	0,181	157	0,2522452
16,237	544,0	544,6	97,60	100,25	0,189	0,180	158	0,2429221
16,165	543,9	544,6	97,97	101,06	0,189	0,181	159	0,2418653
16,287	543,8	544,5	97,23	99,90	0,189	0,181	160	0,2437636
16,385	543,7	544,4	96,63	99,42	0,189	0,181	161	0,2453147
16,106	543,6	544,4	98,06	100,92	0,189	0,181	162	0,2412266
16,076	543,6	544,3	98,40	100,97	0,189	0,180	163	0,2408017
16,506	543,5	544,3	95,73	98,50	0,189	0,180	164	0,2472733
16,100	543,4	544,2	98,15	100,85	0,189	0,180	165	0,2412266
16,163	543,4	544,1	97,58	100,30	0,189	0,180	166	0,2422866
16,266	543,3	544,1	97,04	99,88	0,189	0,180	167	0,2437647
16,157	543,4	544,1	97,89	100,53	0,189	0,180	168	0,2418635
15,859	543,5	544,2	100,00	102,78	0,189	0,180	169	0,2371529
16,147	543,7	544,3	98,41	101,02	0,189	0,180	170	0,2412268
16,123	543,9	544,4	98,62	101,52	0,189	0,180	171	0,2406064
16,212	544,1	544,6	98,28	101,13	0,189	0,180	172	0,2417571
16,358	544,2	544,7	97,32	99,85	0,188	0,180	173	0,2437657
16,454	544,4	544,9	96,92	99,64	0,188	0,180	174	0,2452351
16,275	544,5	545,0	97,56	100,40	0,188	0,180	175	0,2428392
16,493	544,6	545,1	96,18	98,81	0,188	0,180	176	0,2462768
16,252	544,6	545,1	97,42	100,23	0,188	0,180	177	0,2429243
16,239	544,5	545,1	97,36	100,31	0,188	0,180	178	0,2429235
16,024	544,4	545,0	98,69	101,54	0,189	0,180	179	0,239785
16,110	544,3	545,0	98,05	100,79	0,189	0,180	180	0,2412303
16,248	544,2	544,9	97,18	100,17	0,189	0,180	181	0,2433492
16,305	544,1	544,9	96,87	99,63	0,189	0,181	182	0,244269
16,169	544,0	544,9	97,69	100,35	0,189	0,180	183	0,242287
15,992	543,9	544,8	98,65	101,48	0,189	0,180	184	0,2397383
16,132	543,8	544,7	97,79	100,61	0,189	0,181	185	0,2418743
16,256	543,8	544,6	97,12	100,02	0,189	0,181	186	0,2437715
16,252	543,7	544,5	96,84	99,85	0,189	0,181	187	0,2437678
16,249	543,7	544,5	96,90	99,74	0,189	0,181	188	0,2437689
16,244	543,6	544,4	97,04	99,55	0,189	0,180	189	0,2437492
16,215	543,5	544,3	97,23	100,03	0,189	0,180	190	0,2433488
16,111	543,5	544,3	97,92	100,50	0,189	0,181	191	0,2418062
16,241	543,4	544,3	97,08	99,82	0,189	0,181	192	0,2437691
16,179	543,3	544,2	97,42	100,08	0,189	0,181	193	0,2429255
16,346	543,3	544,2	96,48	99,12	0,189	0,181	194	0,2453485
16,092	543,3	544,2	98,04	101,07	0,189	0,181	195	0,2412338
16,080	543,5	544,3	98,51	101,44	0,189	0,181	196	0,2408044
16,468	543,7	544,4	96,40	99,02	0,189	0,181	197	0,2462803
16,048	543,9	544,5	99,04	101,57	0,189	0,180	198	0,2397877
16,300	544,0	544,6	97,47	100,32	0,189	0,180	199	0,2433576
16,439	544,2	544,8	96,89	99,53	0,189	0,180	200	0,2452364
16,178	544,4	544,9	98,41	101,42	0,189	0,180	201	0,2411519
16,234	544,6	545,1	98,20	101,11	0,188	0,180	202	0,2418677
16,341	544,7	545,3	97,63	100,54	0,188	0,180	203	0,2433482
16,500	544,9	545,4	96,70	99,61	0,189	0,180	204	0,2458803
16,291	545,0	545,5	97,62	100,41	0,189	0,180	205	0,2430231
16,657	545,0	545,5	95,39	98,06	0,189	0,180	206	0,2487693
16,547	545,0	545,5	95,73	98,46	0,189	0,180	207	0,2473229
16,274	544,9	545,5	97,24	100,03	0,189	0,180	208	0,2434137
16,456	544,8	545,5	96,15	98,85	0,189	0,180	209	0,2462747
16,251	544,7	545,4	97,20	100,03	0,189	0,180	210	0,2433519
16,442	544,5	545,4	96,13	98,79	0,189	0,180	211	0,2462822
16,574	544,4	545,3	95,19	97,93	0,189	0,180	212	0,2483544
16,188	544,3	545,2	97,33	100,10	0,189	0,180	213	0,2426613
16,386	544,2	545,1	96,25	98,86	0,189	0,180	214	0,2456736
16,391	544,0	544,9	96,09	98,58	0,189	0,180	215	0,2458658
16,512	543,9	544,8	95,35	98,01	0,189	0,180	216	0,2477357
16,348	543,8	544,7	96,43	99,35	0,189	0,181	217	0,245238
16,385	543,7	544,7	96,02	98,92	0,189	0,181	218	0,2458712
16,213	543,6	544,6	97,20	99,78	0,189	0,180	219	0,2433487
16,215	543,6	544,6	97,18	99,84	0,189	0,180	220	0,2433699
16,388	543,5	544,5	96,14	98,95	0,189	0,181	221	0,2458521
16,270	543,6	544,5	97,13	99,94	0,189	0,181	222	0,2437693
16,141	543,7	544,6	98,06	100,77	0,189	0,180	223	0,2415781
16,108	543,8	544,7	98,41	101,38	0,189	0,180	224	0,2408044
16,557	544,0	544,8	96,15	98,54	0,189	0,180	225	0,2473189



16,276	544,1	544,9	97,80	100,48	0,189	0,180	226	0,2429241
15,873	544,3	545,0	100,33	103,06	0,189	0,180	227	0,2367225
16,152	544,5	545,1	98,75	101,47	0,189	0,180	228	0,2408027
16,506	544,6	545,3	96,56	99,22	0,189	0,180	229	0,2462797
16,295	544,6	545,3	97,47	100,31	0,189	0,180	230	0,2433469
16,253	544,6	545,3	97,53	100,38	0,189	0,180	231	0,2429462
16,263	544,6	545,3	97,35	100,14	0,189	0,180	232	0,2432634
16,261	544,5	545,2	97,17	99,92	0,189	0,180	233	0,2433472
16,375	544,4	545,1	96,70	99,07	0,189	0,180	234	0,2452034
16,146	544,3	545,1	97,72	100,56	0,189	0,180	235	0,2418658
16,407	544,2	545,0	96,29	98,91	0,189	0,180	236	0,2458957
16,061	544,0	544,9	98,21	101,00	0,189	0,180	237	0,2408031
16,199	543,9	544,8	97,38	100,10	0,189	0,180	238	0,2429224
16,395	543,8	544,7	96,16	98,90	0,189	0,180	239	0,2458741
15,988	543,7	544,7	98,59	101,19	0,189	0,180	240	0,2398955
16,480	543,6	544,5	95,60	98,38	0,189	0,180	241	0,2473161
16,411	543,5	544,4	96,00	98,67	0,189	0,181	242	0,2462759
16,994	543,4	544,3	92,70	95,33	0,189	0,181	243	0,2550768
16,138	543,3	544,2	97,68	100,31	0,189	0,181	244	0,2422576
16,407	543,2	544,1	96,11	98,73	0,189	0,181	245	0,2462729
16,548	543,1	544,1	95,14	97,81	0,189	0,181	246	0,2484821
15,986	543,0	544,0	98,60	101,24	0,189	0,181	247	0,2400971
16,190	543,0	544,0	97,49	100,11	0,189	0,181	248	0,2429195
15,893	543,1	544,0	99,54	102,26	0,189	0,181	249	0,2382313
16,184	543,2	544,0	97,90	100,53	0,189	0,181	250	0,2422844
16,105	543,4	544,1	98,63	101,45	0,189	0,181	251	0,240798
16,290	543,5	544,2	97,62	100,47	0,189	0,181	252	0,2433404
15,893	543,6	544,3	100,09	102,99	0,189	0,181	253	0,2371492
15,987	543,8	544,4	99,81	102,52	0,189	0,180	254	0,2384067
16,350	543,9	544,6	97,46	100,50	0,189	0,181	255	0,2437597
16,276	544,1	544,7	97,67	100,41	0,189	0,180	256	0,2429173
16,480	544,1	544,7	96,41	99,02	0,189	0,180	257	0,2462736
16,101	544,1	544,8	98,53	101,12	0,189	0,180	258	0,2407944
16,523	544,0	544,7	95,68	98,45	0,189	0,180	259	0,247312
16,179	543,9	544,7	97,67	100,69	0,189	0,181	260	0,2422841
16,368	543,8	544,6	96,61	99,24	0,189	0,181	261	0,2452332
16,265	543,7	544,6	97,03	99,73	0,189	0,180	262	0,2437598
16,195	543,6	544,5	97,40	100,20	0,189	0,180	263	0,2428515
15,858	543,5	544,4	99,52	102,14	0,189	0,180	264	0,2378727
16,609	543,4	544,3	94,94	97,46	0,189	0,180	265	0,2491684
16,573	543,3	544,2	95,11	97,60	0,189	0,180	266	0,2487582
16,376	543,2	544,1	96,27	98,98	0,189	0,181	267	0,2458541
16,201	543,0	544,0	97,27	99,84	0,189	0,181	268	0,2433388
16,397	542,9	543,9	95,97	98,59	0,189	0,181	269	0,2462348
16,063	542,8	543,8	98,07	100,78	0,189	0,181	270	0,2412195
16,216	542,7	543,7	97,08	99,82	0,189	0,181	271	0,2435725
16,564	542,7	543,7	95,13	97,71	0,189	0,181	272	0,2487823
16,170	542,6	543,6	97,44	99,86	0,189	0,181	273	0,2429447
16,043	542,6	543,5	98,41	101,00	0,189	0,181	274	0,2407938
15,971	542,6	543,6	98,91	101,89	0,189	0,181	275	0,2394549
16,184	542,8	543,7	98,02	100,75	0,189	0,181	276	0,2422795
16,034	543,0	543,8	99,15	102,16	0,189	0,181	277	0,2397258
15,847	543,2	543,9	100,36	103,11	0,189	0,181	278	0,2367134
15,947	543,3	544,0	99,92	102,91	0,189	0,181	279	0,2379913
15,949	543,5	544,1	100,11	103,00	0,189	0,181	280	0,2377924
16,176	543,6	544,3	98,68	101,17	0,189	0,180	281	0,241218
16,313	543,7	544,3	97,62	100,25	0,189	0,180	282	0,2435228
16,112	543,8	544,4	98,59	101,26	0,189	0,180	283	0,2408009
16,392	543,8	544,4	96,67	99,69	0,189	0,181	284	0,2452247
16,116	543,7	544,4	98,23	100,80	0,189	0,181	285	0,2413248
16,628	543,6	544,3	95,17	97,71	0,189	0,180	286	0,2491287
16,263	543,5	544,3	97,14	100,32	0,189	0,181	287	0,2437567
16,593	543,4	544,2	95,27	97,86	0,189	0,181	288	0,2487553
15,954	543,3	544,1	99,04	101,70	0,189	0,181	289	0,239309
16,385	543,2	544,0	96,29	99,14	0,189	0,181	290	0,2458244
16,116	543,1	543,9	97,91	100,54	0,189	0,181	291	0,2418558
16,354	543,0	543,9	96,48	99,11	0,189	0,181	292	0,2454562
16,193	542,9	543,8	97,26	99,88	0,189	0,181	293	0,2431023
16,233	542,8	543,8	97,12	99,77	0,189	0,181	294	0,2437561
16,105	542,7	543,7	97,73	100,65	0,189	0,181	295	0,2418728
16,136	542,7	543,6	97,71	100,39	0,189	0,181	296	0,2423193
15,934	542,6	543,5	98,89	101,56	0,189	0,181	297	0,2392979
15,877	542,6	543,5	99,40	102,24	0,189	0,181	298	0,2382204
16,060	542,7	543,5	98,46	101,15	0,189	0,181	299	0,2407149
15,993	542,9	543,6	99,05	102,16	0,189	0,181	300	0,2392955
16,279	543,0	543,7	97,75	100,43	0,189	0,181	301	0,2433334
16,097	543,1	543,8	99,09	101,64	0,189	0,181	302	0,2403221
15,907	543,2	543,9	100,42	103,25	0,189	0,181	303	0,2372372

16,057	543,4	544,0	99,48	102,34	0,189	0,181	304	0,2392983
16,202	543,6	544,1	98,83	101,61	0,189	0,181	305	0,2412158
16,193	543,7	544,3	98,97	101,70	0,189	0,181	306	0,2409942
16,115	543,9	544,4	99,46	102,34	0,189	0,181	307	0,2397232
15,818	544,1	544,6	101,52	104,50	0,189	0,181	308	0,2351892
16,233	544,3	544,7	98,88	101,63	0,189	0,181	309	0,2412164
16,084	544,4	544,9	99,72	102,80	0,189	0,180	310	0,2389626
16,391	544,6	545,0	97,99	100,84	0,189	0,181	311	0,2434485
15,966	544,7	545,2	100,49	103,44	0,189	0,180	312	0,2371474
16,121	544,9	545,3	99,66	102,53	0,188	0,180	313	0,239297
16,118	545,0	545,5	99,22	102,42	0,188	0,180	314	0,2396061
16,342	545,1	545,5	97,70	100,40	0,188	0,180	315	0,2433354
16,144	545,0	545,5	98,41	101,50	0,188	0,180	316	0,2407936
16,266	544,9	545,5	97,82	100,38	0,189	0,180	317	0,2429141
16,136	544,8	545,4	98,35	101,05	0,189	0,180	318	0,2412192
16,268	544,6	545,3	97,26	100,01	0,189	0,180	319	0,243341
16,258	544,5	545,2	97,33	100,29	0,189	0,180	320	0,2433365
16,109	544,3	545,1	98,21	101,03	0,189	0,181	321	0,2412191
16,371	544,2	545,0	96,27	99,51	0,189	0,181	322	0,2452244
16,365	544,0	544,9	96,65	99,23	0,189	0,181	323	0,245226
16,403	543,9	544,8	96,22	99,01	0,189	0,180	324	0,2458526
16,147	543,8	544,7	98,07	100,84	0,189	0,181	325	0,2418853
16,098	543,9	544,7	98,57	101,43	0,189	0,181	326	0,2407924
16,117	544,0	544,7	98,73	101,26	0,189	0,181	327	0,2407929
16,111	544,1	544,8	98,78	101,79	0,189	0,180	328	0,2403448
16,090	544,2	544,9	99,24	102,10	0,189	0,181	329	0,239726
16,178	544,4	545,0	99,02	101,75	0,189	0,180	330	0,2407937
16,330	544,5	545,1	97,99	100,92	0,189	0,180	331	0,2429128
16,177	544,7	545,3	99,09	101,85	0,189	0,180	332	0,2404583
16,713	544,8	545,4	96,04	98,67	0,189	0,180	333	0,2483351
16,115	545,0	545,5	99,62	102,44	0,189	0,180	334	0,2392986
16,228	545,1	545,6	99,10	102,06	0,189	0,180	335	0,2407936
16,340	545,3	545,8	98,28	101,06	0,189	0,180	336	0,242741
16,476	545,3	545,8	97,09	99,99	0,189	0,180	337	0,2452268
16,221	545,3	545,9	98,27	101,00	0,189	0,180	338	0,2418572
16,537	545,2	545,8	96,20	98,91	0,189	0,180	339	0,24688
16,288	545,1	545,8	97,38	100,13	0,189	0,180	340	0,2433373
16,204	545,0	545,7	97,82	100,66	0,189	0,180	341	0,2422802
16,188	544,8	545,6	97,84	100,74	0,189	0,181	342	0,2421906
16,384	544,7	545,5	96,66	99,33	0,189	0,181	343	0,2452247
16,516	544,5	545,4	95,70	98,30	0,189	0,180	344	0,247309
16,218	544,4	545,3	97,41	100,28	0,189	0,180	345	0,2429162
15,901	544,3	545,2	99,24	102,08	0,189	0,180	346	0,2382254
16,434	544,2	545,1	96,14	98,79	0,189	0,180	347	0,2462695
16,359	544,1	545,0	96,56	99,21	0,189	0,180	348	0,2452256
16,426	544,0	544,9	96,01	98,61	0,189	0,180	349	0,2462686
15,877	543,9	544,8	99,60	102,29	0,189	0,180	350	0,2377932
16,028	544,0	544,8	98,94	101,59	0,189	0,180	351	0,2397264
16,121	544,1	544,9	98,51	101,55	0,189	0,180	352	0,2407935
16,116	544,2	545,0	98,86	101,48	0,189	0,180	353	0,2403825
16,087	544,3	545,1	99,21	101,97	0,189	0,180	354	0,2397276
16,211	544,5	545,2	98,88	101,31	0,189	0,180	355	0,2412174
16,093	544,7	545,3	99,53	102,45	0,189	0,180	356	0,2392973
16,205	544,8	545,4	98,92	101,83	0,189	0,180	357	0,2407939
16,145	545,0	545,6	99,42	102,35	0,188	0,180	358	0,2397277
16,175	545,2	545,7	99,39	102,30	0,188	0,180	359	0,240023
16,195	545,3	545,8	98,84	101,92	0,188	0,180	360	0,2407708
16,138	545,3	545,9	98,94	101,41	0,189	0,180	361	0,2403696
16,141	545,3	545,9	98,64	101,19	0,189	0,180	362	0,2407952
16,125	545,2	545,9	98,43	101,16	0,189	0,180	363	0,2407951
16,195	545,1	545,8	97,89	100,71	0,189	0,180	364	0,2420321
16,176	545,0	545,7	97,90	100,74	0,189	0,180	365	0,2419012
16,293	544,8	545,6	97,12	99,78	0,189	0,180	366	0,2437595
16,074	544,7	545,5	98,50	101,09	0,189	0,180	367	0,2406126
16,251	544,6	545,4	97,29	99,95	0,189	0,180	368	0,2433411
16,104	544,5	545,3	98,07	100,90	0,189	0,180	369	0,2412206
16,143	544,3	545,2	97,75	100,67	0,189	0,180	370	0,2418568
16,236	544,2	545,1	97,30	100,08	0,189	0,181	371	0,2433182
16,164	544,2	545,0	97,68	100,60	0,189	0,181	372	0,2422831
16,161	544,1	545,0	97,78	100,51	0,189	0,181	373	0,2422798
16,324	544,0	544,9	96,68	99,50	0,189	0,181	374	0,2447595
16,209	543,9	544,8	97,45	100,06	0,189	0,180	375	0,2429219
16,263	544,0	544,8	97,30	100,15	0,189	0,180	376	0,2433357
16,037	544,1	544,9	98,98	101,98	0,189	0,181	377	0,2396791
16,060	544,2	545,0	99,16	102,02	0,189	0,181	378	0,2397221
15,773	544,3	545,1	101,21	104,14	0,189	0,181	379	0,2351904
15,998	544,5	545,2	99,93	102,63	0,189	0,180	380	0,2382241
16,188	544,6	545,3	98,93	101,92	0,189	0,180	381	0,2407933

16,168	544,8	545,4	99,10	101,79	0,189	0,180	382	0,24036
15,932	544,9	545,5	100,78	103,50	0,189	0,180	383	0,2367131
16,195	545,1	545,6	98,81	101,53	0,189	0,180	384	0,2409594
16,130	545,1	545,7	98,84	101,90	0,189	0,180	385	0,2403676
16,206	545,1	545,7	98,07	100,66	0,189	0,180	386	0,2418643
16,147	545,0	545,7	98,29	100,98	0,189	0,180	387	0,2412195
16,403	544,9	545,6	96,73	99,44	0,189	0,180	388	0,2452261
16,235	544,8	545,6	97,46	100,54	0,189	0,181	389	0,242885
16,454	544,7	545,5	96,13	98,90	0,189	0,181	390	0,2462706
16,110	544,6	545,4	98,26	100,98	0,189	0,180	391	0,2412191
16,320	544,4	545,3	96,88	99,41	0,189	0,180	392	0,2444853
16,169	544,3	545,2	97,73	100,43	0,189	0,180	393	0,2422814
16,137	544,2	545,1	97,85	100,56	0,189	0,180	394	0,2418569
16,427	544,1	545,0	96,26	98,80	0,189	0,180	395	0,246269
16,342	544,0	545,0	96,74	99,43	0,189	0,181	396	0,2450492
16,198	543,9	544,9	97,41	100,20	0,189	0,181	397	0,2429143
16,559	543,8	544,8	95,28	98,00	0,189	0,181	398	0,2483429
16,199	543,8	544,7	97,40	100,21	0,189	0,181	399	0,2429144
16,179	543,8	544,7	97,83	100,61	0,189	0,181	400	0,2422787
16,076	543,9	544,8	98,63	101,53	0,189	0,181	401	0,2403673
16,097	544,0	544,8	98,97	101,65	0,189	0,181	402	0,2403631
16,146	544,2	544,9	98,62	101,48	0,189	0,180	403	0,2407928
16,238	544,3	545,0	98,46	101,24	0,189	0,180	404	0,2418547
16,126	544,5	545,1	99,15	102,14	0,189	0,180	405	0,2399673
15,951	544,6	545,3	100,57	103,32	0,189	0,180	406	0,2371444
16,109	544,8	545,4	99,71	102,44	0,189	0,180	407	0,2393057
16,022	544,9	545,5	99,88	102,94	0,189	0,180	408	0,2382271
16,224	545,0	545,6	98,32	101,26	0,188	0,180	409	0,2416749
16,478	545,0	545,6	96,57	99,24	0,189	0,180	410	0,2458517
16,148	544,9	545,6	98,32	101,17	0,189	0,180	411	0,2412192
16,134	544,8	545,5	98,16	100,97	0,189	0,180	412	0,2412195
16,260	544,7	545,5	97,34	100,20	0,189	0,180	413	0,2432782
16,085	544,6	545,4	98,24	100,92	0,189	0,180	414	0,2407936
16,247	544,5	545,3	97,27	99,88	0,189	0,180	415	0,2433353
16,508	544,3	545,2	95,67	98,36	0,189	0,180	416	0,2473072
16,503	544,2	545,1	95,63	98,31	0,189	0,180	417	0,2473245
16,134	544,1	545,0	97,92	100,67	0,189	0,180	418	0,2418595
16,200	544,0	544,9	97,42	100,13	0,189	0,181	419	0,2429128
16,199	543,9	544,9	97,35	100,18	0,189	0,181	420	0,2429132
16,194	543,8	544,8	97,46	100,09	0,189	0,181	421	0,2429125
16,219	543,7	544,7	97,22	99,98	0,189	0,181	422	0,2433364
16,194	543,6	544,6	97,41	100,08	0,189	0,181	423	0,2428939
16,178	543,7	544,6	97,76	100,45	0,189	0,180	424	0,242287
16,195	543,8	544,6	97,94	100,57	0,189	0,180	425	0,2422826
15,922	543,9	544,7	99,97	102,66	0,189	0,180	426	0,2377907
15,942	544,0	544,8	100,24	102,73	0,189	0,180	427	0,2377701
15,894	544,2	544,9	100,52	103,65	0,189	0,181	428	0,2367106
16,083	544,3	545,0	99,58	102,28	0,189	0,180	429	0,2392945
15,783	544,5	545,1	101,39	104,54	0,188	0,180	430	0,2345348
16,109	544,6	545,3	99,86	102,73	0,189	0,180	431	0,2392973
16,166	544,8	545,4	99,24	102,29	0,189	0,181	432	0,2401361
16,173	544,9	545,5	98,87	101,70	0,189	0,180	433	0,2407912
16,246	544,9	545,5	98,18	100,76	0,189	0,180	434	0,2422787
16,322	544,9	545,5	97,37	100,21	0,189	0,180	435	0,243766
16,244	544,8	545,5	97,68	100,38	0,189	0,180	436	0,2428247
16,433	544,7	545,4	96,59	99,01	0,189	0,180	437	0,2458508
16,382	544,6	545,3	96,59	99,14	0,189	0,180	438	0,2452254
16,399	544,5	545,3	96,59	99,09	0,189	0,180	439	0,2456045
16,267	544,4	545,2	97,11	99,57	0,189	0,180	440	0,2437563
16,232	544,2	545,1	97,25	100,00	0,189	0,180	441	0,2433348
16,250	544,2	545,0	97,20	99,84	0,189	0,180	442	0,2436219
16,421	544,1	544,9	96,16	98,75	0,189	0,180	443	0,2462693
16,222	544,0	544,9	97,27	99,94	0,189	0,181	444	0,2433357
16,155	543,9	544,8	97,61	100,23	0,189	0,180	445	0,242346
16,146	543,8	544,7	97,63	100,06	0,189	0,180	446	0,2422833
16,411	543,7	544,7	96,03	98,72	0,189	0,180	447	0,2462668
15,988	543,7	544,6	98,77	101,59	0,189	0,181	448	0,239724
16,285	543,7	544,6	97,23	100,06	0,189	0,181	449	0,2437548
15,863	543,9	544,6	100,05	102,88	0,189	0,181	450	0,2371428
16,132	544,0	544,7	98,64	101,33	0,189	0,180	451	0,2407918
15,809	544,1	544,8	101,01	103,71	0,189	0,180	452	0,235626
16,115	544,3	544,9	99,31	102,08	0,189	0,180	453	0,2398417
15,890	544,4	545,0	100,82	103,78	0,189	0,180	454	0,2362771
16,210	544,6	545,1	99,12	101,94	0,189	0,180	455	0,2407922
16,174	544,8	545,3	99,32	102,03	0,189	0,180	456	0,2401955
16,666	544,9	545,4	96,07	98,61	0,189	0,180	457	0,247939
16,126	545,0	545,5	98,91	101,77	0,189	0,180	458	0,2403655
16,229	545,0	545,5	97,93	100,76	0,189	0,180	459	0,2422786

16,139	544,9	545,4	98,29	101,33	0,189	0,181	460	0,2412181
16,030	544,8	545,4	98,79	101,53	0,189	0,181	461	0,2398073
16,256	544,7	545,3	97,29	100,01	0,189	0,180	462	0,2433361
16,249	544,6	545,3	97,31	100,11	0,189	0,180	463	0,2433425
16,436	544,5	545,2	96,02	98,95	0,189	0,181	464	0,2462678
16,430	544,4	545,1	96,07	98,80	0,189	0,181	465	0,2462673
16,201	544,3	545,1	97,40	100,00	0,189	0,180	466	0,2429129
16,126	544,2	545,0	97,80	100,62	0,189	0,180	467	0,2418574
16,153	544,1	544,9	97,54	100,46	0,189	0,181	468	0,2422785
16,189	544,0	544,8	97,43	100,19	0,189	0,181	469	0,2429126
16,216	543,9	544,7	97,17	99,91	0,189	0,181	470	0,2433353
16,167	543,8	544,7	97,47	100,26	0,189	0,181	471	0,2426266
16,013	543,8	544,6	98,24	101,28	0,189	0,181	472	0,2403651

Average	Average	Average	Proportional Rates Medium/low fire					Average
17,43	Inlet +	Inlet +						0,253
	Outlet	Outlet	Average	Average	#1	#2		
Tunnel	Temp.	Temp.	97,20	99,44	System 1	System 2		SQRT
Velocity	Meter 1	Meter 2	Proportional Rates		Vol.Std.	Vol.Std.		Delta-P
			PR1	PR2			Time	
Ft/Sec	Deg. R	Deg. R	%	%	(ft3)	(ft3)	min	(in H2O)2
16,505	538,4	538,3			0,186	0,178	0	0,2340859
16,419	538,8	538,5	106,64	109,23	0,186	0,178	1	0,2351807
16,756	539,1	538,8	104,95	107,46	0,186	0,178	2	0,2392855
16,603	539,3	539,0	106,61	109,09	0,185	0,177	3	0,2362667
16,682	539,6	539,3	106,66	109,41	0,185	0,177	4	0,2367008
16,524	539,9	539,6	108,27	111,02	0,185	0,177	5	0,2336563
16,676	540,1	539,8	107,42	110,30	0,185	0,177	6	0,2356106
16,481	540,3	540,0	109,09	111,76	0,185	0,177	7	0,2324789
16,585	540,4	540,1	108,69	111,41	0,185	0,177	8	0,2336501
16,603	540,5	540,2	108,77	111,19	0,185	0,177	9	0,2336509
16,980	540,6	540,3	106,45	109,10	0,185	0,177	10	0,2388577
16,767	540,7	540,4	107,91	110,32	0,185	0,177	11	0,2357708
16,722	540,7	540,5	108,08	110,83	0,185	0,177	12	0,2351529
17,679	540,7	540,6	101,16	103,35	0,185	0,177	13	0,2501886
17,426	540,7	540,6	101,50	104,03	0,185	0,177	14	0,2478001
17,216	540,8	540,7	102,02	104,63	0,185	0,177	15	0,2458591
17,388	540,9	540,7	100,21	102,66	0,185	0,177	16	0,2491632
17,345	541,0	540,8	100,38	102,79	0,185	0,177	17	0,2487501
17,410	541,0	540,9	99,82	102,31	0,185	0,177	18	0,2498029
17,434	541,0	540,9	99,84	102,18	0,185	0,177	19	0,2501904
17,671	541,0	541,0	98,40	100,51	0,185	0,177	20	0,2536502
17,287	541,1	541,0	100,40	102,72	0,185	0,177	21	0,2483523
17,416	541,1	541,0	99,61	102,04	0,185	0,177	22	0,250206
17,486	541,2	541,1	99,24	101,75	0,185	0,177	23	0,2512114
17,215	541,2	541,1	100,79	103,20	0,185	0,177	24	0,2473388
17,480	541,3	541,2	99,25	101,48	0,186	0,177	25	0,251416
17,500	541,3	541,2	99,13	101,52	0,186	0,178	26	0,2516145
17,298	541,3	541,3	100,15	102,62	0,185	0,178	27	0,2487114
17,332	541,3	541,3	100,06	102,37	0,185	0,177	28	0,2491869
17,472	541,4	541,3	99,21	101,36	0,185	0,177	29	0,2512138
17,318	541,4	541,4	99,89	102,28	0,185	0,177	30	0,2490704
17,279	541,5	541,5	100,08	102,47	0,185	0,177	31	0,2485235
17,373	541,6	541,5	99,65	102,05	0,185	0,177	32	0,2497826
17,368	541,6	541,6	99,61	102,03	0,185	0,177	33	0,2497815
17,606	541,7	541,6	98,18	100,31	0,185	0,177	34	0,2532429
17,219	541,8	541,7	100,34	102,79	0,185	0,177	35	0,2477695
17,430	541,8	541,7	99,08	101,31	0,185	0,177	36	0,250807
17,382	541,7	541,7	99,27	101,85	0,185	0,177	37	0,2501936
17,487	541,8	541,8	98,84	101,01	0,185	0,177	38	0,2516615
17,734	541,9	541,8	97,69	99,98	0,185	0,177	39	0,2550664
17,488	542,0	541,9	98,81	100,92	0,185	0,177	40	0,2516248
17,280	542,0	542,0	99,88	101,98	0,185	0,177	41	0,2487556
17,409	542,0	542,1	99,00	101,39	0,185	0,177	42	0,2508117
17,514	542,1	542,1	98,51	100,86	0,185	0,177	43	0,2522365
17,407	542,1	542,1	98,91	101,35	0,185	0,177	44	0,2508038
17,454	542,1	542,1	98,47	100,87	0,185	0,177	45	0,2516193
17,401	542,2	542,2	98,64	101,12	0,185	0,177	46	0,2508094
17,203	542,2	542,2	99,82	102,21	0,185	0,177	47	0,248117
17,364	542,2	542,3	99,16	101,68	0,185	0,177	48	0,2501936
17,360	542,3	542,3	98,95	101,39	0,185	0,177	49	0,2501956
17,481	542,3	542,4	98,37	100,83	0,185	0,177	50	0,2518958
17,357	542,3	542,4	98,98	101,40	0,185	0,177	51	0,2501949
17,225	542,4	542,5	99,77	102,13	0,185	0,177	52	0,2483436
17,387	542,4	542,5	98,66	101,03	0,185	0,177	53	0,2508095
17,283	542,5	542,6	99,41	101,73	0,185	0,177	54	0,2491697
17,323	542,6	542,6	99,07	101,56	0,185	0,177	55	0,2497841
17,363	542,6	542,6	98,72	101,02	0,185	0,177	56	0,2505523
17,268	542,6	542,7	99,20	101,68	0,185	0,177	57	0,2491689
17,437	542,5	542,7	98,28	100,54	0,185	0,177	58	0,2516275
17,235	542,5	542,7	99,28	101,65	0,185	0,176	59	0,248757
17,242	542,5	542,7	99,05	101,45	0,185	0,177	60	0,2491694
17,569	542,5	542,7	97,23	99,63	0,184	0,177	61	0,2536551
17,258	542,6	542,8	99,16	101,47	0,184	0,176	62	0,2491686
17,223	542,6	542,8	99,33	101,79	0,185	0,177	63	0,2487644
17,420	542,6	542,8	98,16	100,52	0,185	0,177	64	0,2516124
17,230	542,7	542,9	99,20	101,65	0,184	0,177	65	0,2487575

17,254	542,7	542,9	98,98	101,17	0,184	0,176	66	0,2491813
17,565	542,7	542,9	97,24	99,72	0,184	0,176	67	0,2536577
17,470	542,8	543,0	97,82	100,12	0,184	0,176	68	0,2522387
17,471	542,8	543,0	97,96	100,04	0,184	0,176	69	0,252239
17,426	542,8	543,0	98,06	100,44	0,184	0,176	70	0,2516284
17,301	542,9	543,1	98,76	101,14	0,184	0,176	71	0,2497865
17,550	543,0	543,1	97,40	99,75	0,184	0,176	72	0,2533732
17,302	543,0	543,1	98,71	100,72	0,184	0,176	73	0,2498085
17,257	543,0	543,1	99,01	101,38	0,184	0,176	74	0,2491719
17,188	543,0	543,1	99,30	101,75	0,184	0,176	75	0,2483556
17,415	542,9	543,1	97,95	100,21	0,184	0,176	76	0,2516327
17,407	542,9	543,1	98,04	100,43	0,184	0,176	77	0,2514286
17,217	542,9	543,1	99,05	101,51	0,184	0,176	78	0,2487495
17,244	542,9	543,2	98,88	101,24	0,184	0,176	79	0,2491655
17,282	542,9	543,2	98,68	101,08	0,184	0,176	80	0,2497874
17,523	542,9	543,2	97,29	99,47	0,184	0,176	81	0,253255
17,403	542,9	543,2	97,99	100,07	0,184	0,176	82	0,2516553
17,075	542,9	543,2	99,80	102,25	0,184	0,176	83	0,2468972
17,277	542,9	543,2	98,69	100,92	0,184	0,176	84	0,2497921
17,209	543,0	543,3	99,05	101,24	0,184	0,176	85	0,2487604
17,260	543,1	543,3	98,56	100,90	0,184	0,176	86	0,2497877
17,393	543,1	543,4	97,76	100,19	0,184	0,176	87	0,25163
17,396	543,1	543,4	97,72	100,17	0,184	0,176	88	0,2516282
17,158	543,0	543,4	99,01	101,34	0,184	0,176	89	0,2483475
17,588	543,0	543,4	96,51	98,73	0,184	0,176	90	0,2546686
17,373	543,0	543,3	97,71	99,90	0,184	0,176	91	0,2516302
17,539	543,1	543,4	96,66	99,18	0,184	0,176	92	0,2540645
17,309	543,1	543,4	98,07	100,55	0,184	0,176	93	0,2506314
17,468	543,2	543,5	97,22	99,63	0,184	0,176	94	0,2529285
17,505	543,2	543,5	96,71	99,08	0,184	0,176	95	0,2536591
17,607	543,2	543,5	96,40	98,75	0,184	0,176	96	0,2550725
17,998	543,2	543,5	94,22	96,69	0,184	0,177	97	0,26084
17,308	543,1	543,5	97,97	100,22	0,184	0,176	98	0,2508042
17,333	543,1	543,5	97,78	99,96	0,184	0,176	99	0,2512227
17,341	543,1	543,5	97,88	99,93	0,184	0,176	100	0,2512218
17,360	543,0	543,4	97,63	99,75	0,184	0,176	101	0,2516311
17,161	543,0	543,4	98,71	100,99	0,184	0,176	102	0,2487605
17,215	543,0	543,4	98,18	100,58	0,184	0,176	103	0,2497886
17,454	543,1	543,5	96,99	99,15	0,184	0,176	104	0,2531372
17,323	543,1	543,5	97,74	100,04	0,184	0,176	105	0,2512228
17,283	543,1	543,5	97,96	100,17	0,184	0,176	106	0,2506507
17,597	543,1	543,5	96,14	98,32	0,184	0,176	107	0,2553112
17,249	543,1	543,5	98,11	100,45	0,184	0,176	108	0,2501994
17,214	543,1	543,5	98,12	100,41	0,184	0,176	109	0,2497887
17,527	543,1	543,5	96,16	98,50	0,184	0,176	110	0,2546694
17,299	543,1	543,5	97,50	99,94	0,184	0,176	111	0,2512217
17,307	543,1	543,5	97,53	99,80	0,184	0,176	112	0,2512235
17,549	543,1	543,5	96,29	98,37	0,184	0,176	113	0,2546677
17,323	543,1	543,5	97,32	99,70	0,184	0,176	114	0,2516296
17,467	543,1	543,5	96,50	98,86	0,184	0,176	115	0,2536603
17,569	543,1	543,5	96,15	98,48	0,184	0,176	116	0,2550729
17,184	543,1	543,5	98,07	100,31	0,184	0,176	117	0,2497889
17,455	543,1	543,5	96,73	98,82	0,184	0,176	118	0,2535259
17,313	543,0	543,5	97,29	99,67	0,184	0,176	119	0,2516091
17,318	543,0	543,5	97,27	99,79	0,184	0,176	120	0,2516312
17,561	543,0	543,5	96,16	98,37	0,184	0,176	121	0,2550735
17,291	543,0	543,5	97,50	99,85	0,184	0,176	122	0,2512219
17,293	543,1	543,5	97,62	99,73	0,184	0,176	123	0,2512225
17,326	543,1	543,5	97,26	99,71	0,184	0,176	124	0,2516558
17,454	543,1	543,5	96,63	98,93	0,184	0,176	125	0,2536617
17,425	543,1	543,6	96,78	98,86	0,184	0,176	126	0,2532558
17,419	543,1	543,6	96,79	98,92	0,184	0,176	127	0,2532584
17,425	543,1	543,6	96,79	99,13	0,184	0,176	128	0,2532582
17,263	543,1	543,6	97,71	100,19	0,184	0,176	129	0,2508128
17,320	543,1	543,6	97,58	99,56	0,184	0,176	130	0,2516323
17,312	543,1	543,6	97,52	99,71	0,185	0,176	131	0,2515688
17,609	543,1	543,6	95,58	97,97	0,184	0,176	132	0,2560564
17,346	543,0	543,6	97,03	99,37	0,184	0,176	133	0,2522441
17,350	543,0	543,5	97,10	99,21	0,184	0,176	134	0,2523331
17,436	543,0	543,5	96,63	98,64	0,184	0,176	135	0,2536644
17,245	543,0	543,6	97,65	100,11	0,184	0,176	136	0,2508157
17,498	542,9	543,5	96,37	98,46	0,184	0,176	137	0,2545017
17,599	542,9	543,5	95,79	97,92	0,185	0,176	138	0,2560791

17,299	542,9	543,5	97,40	99,51	0,185	0,176	139	0,2516328
17,405	542,8	543,5	96,74	98,84	0,184	0,176	140	0,2532596
17,458	542,8	543,4	96,43	98,41	0,184	0,176	141	0,2540681
17,459	542,8	543,4	96,39	98,44	0,184	0,176	142	0,2540445
17,523	542,8	543,4	95,93	97,99	0,184	0,176	143	0,2550762
17,524	542,8	543,4	96,09	98,14	0,184	0,176	144	0,255076
17,451	542,8	543,4	96,30	98,52	0,184	0,176	145	0,2540684
17,307	542,7	543,4	97,05	99,39	0,184	0,176	146	0,2520758
17,517	542,7	543,4	95,94	98,25	0,184	0,176	147	0,2550757
17,387	542,7	543,4	96,50	98,76	0,184	0,176	148	0,2532541
17,485	542,7	543,4	96,14	98,21	0,184	0,176	149	0,2546729
17,488	542,7	543,4	96,19	98,25	0,185	0,176	150	0,254646
17,447	542,7	543,4	96,49	98,57	0,185	0,176	151	0,2540684
17,517	542,7	543,3	95,88	98,31	0,185	0,176	152	0,2550751
17,488	542,6	543,3	96,09	98,19	0,184	0,176	153	0,2546806
17,416	542,6	543,3	96,42	98,63	0,184	0,176	154	0,2536631
17,584	542,5	543,2	95,64	97,76	0,184	0,176	155	0,2560782
17,519	542,5	543,2	95,83	98,30	0,184	0,176	156	0,2550749
17,311	542,5	543,2	97,05	99,14	0,184	0,176	157	0,2522432
17,278	542,4	543,1	97,20	99,64	0,184	0,176	158	0,2516347
17,413	542,4	543,1	96,54	98,62	0,184	0,176	159	0,2536629
17,465	542,4	543,2	96,16	98,09	0,185	0,176	160	0,2545438
17,219	542,4	543,1	97,65	99,82	0,185	0,176	161	0,2508166
17,508	542,4	543,1	95,84	98,18	0,184	0,176	162	0,2550749
17,500	542,4	543,1	95,90	98,12	0,184	0,176	163	0,2550763
17,248	542,4	543,1	97,12	99,56	0,185	0,177	164	0,2516321
17,440	542,5	543,1	96,30	98,51	0,184	0,176	165	0,2540672
17,337	542,6	543,2	97,14	99,38	0,184	0,176	166	0,252243
17,252	542,7	543,3	97,81	100,01	0,184	0,176	167	0,2508193
17,323	542,9	543,4	97,54	99,88	0,184	0,176	168	0,2516242
17,507	543,1	543,5	96,60	98,86	0,184	0,176	169	0,2541477
17,386	543,2	543,7	97,25	99,34	0,184	0,176	170	0,2522483
17,491	543,4	543,8	96,74	99,27	0,184	0,176	171	0,2536032
17,431	543,6	544,0	97,34	99,39	0,184	0,176	172	0,2525828
17,483	543,8	544,2	96,98	99,40	0,184	0,176	173	0,2532469
17,667	544,0	544,3	95,76	98,05	0,184	0,176	174	0,2560796
17,509	544,1	544,5	96,45	98,78	0,184	0,176	175	0,2540696
17,641	544,1	544,5	95,57	98,12	0,184	0,176	176	0,256077
17,527	544,1	544,6	96,16	98,33	0,184	0,176	177	0,2546741
17,549	544,1	544,6	96,13	98,32	0,184	0,176	178	0,2550768
17,542	544,0	544,6	96,07	98,48	0,184	0,176	179	0,2550775
17,565	544,0	544,6	95,96	98,02	0,184	0,176	180	0,2554795
17,593	543,9	544,6	95,79	97,86	0,185	0,176	181	0,2560811
17,520	543,8	544,5	96,20	98,17	0,185	0,176	182	0,2550781
17,392	543,7	544,4	96,70	98,92	0,185	0,176	183	0,2532615
17,325	543,6	544,4	97,07	99,21	0,185	0,176	184	0,2522476
17,522	543,6	544,4	96,01	98,20	0,185	0,176	185	0,2551631
17,409	543,6	544,3	96,56	98,62	0,185	0,176	186	0,253613
17,505	543,5	544,3	96,05	98,02	0,185	0,176	187	0,2550775
17,218	543,5	544,3	97,64	99,76	0,185	0,176	188	0,2508658
17,311	543,5	544,3	97,16	99,10	0,185	0,176	189	0,2522452
17,239	543,4	544,3	97,50	99,51	0,185	0,176	190	0,2512283
17,505	543,4	544,2	95,99	98,25	0,185	0,176	191	0,2550778
17,498	543,4	544,2	95,99	98,04	0,185	0,176	192	0,2550783
17,495	543,4	544,2	96,03	97,93	0,185	0,176	193	0,2550781
17,393	543,5	544,2	96,76	98,83	0,185	0,176	194	0,2532616
17,606	543,6	544,3	95,79	97,94	0,185	0,176	195	0,2560811
17,291	543,8	544,4	97,60	99,92	0,184	0,176	196	0,2512281
17,505	544,0	544,5	96,64	99,03	0,184	0,176	197	0,2540716
17,320	544,2	544,6	97,74	100,01	0,184	0,176	198	0,2512284
17,564	544,3	544,8	96,36	98,52	0,184	0,176	199	0,2546756
17,548	544,4	544,9	96,22	98,59	0,184	0,176	200	0,2546751
17,569	544,4	544,9	96,10	98,54	0,184	0,176	201	0,2550796
17,620	544,4	545,0	95,81	97,82	0,184	0,176	202	0,2560877
17,678	544,4	544,9	95,13	97,49	0,184	0,176	203	0,2570812
17,534	544,4	545,0	95,76	98,01	0,184	0,176	204	0,2551055
17,516	544,3	544,9	95,83	98,16	0,184	0,176	205	0,2550256
17,611	544,2	544,9	95,26	97,51	0,184	0,176	206	0,2564843
17,510	544,1	544,8	95,95	97,92	0,184	0,176	207	0,2550799
17,507	544,0	544,8	95,64	98,04	0,184	0,176	208	0,2550605
17,497	543,9	544,7	95,69	97,70	0,184	0,176	209	0,2550801
17,569	543,8	544,6	95,40	97,38	0,184	0,176	210	0,2560838
17,466	543,7	544,5	95,88	97,92	0,184	0,176	211	0,2546775

17,499	543,6	544,5	95,72	97,61	0,184	0,176	212	0,2552157
17,395	543,6	544,4	96,22	98,42	0,184	0,176	213	0,2536671
17,249	543,5	544,3	97,02	99,07	0,184	0,176	214	0,2516384
17,606	543,4	544,2	95,12	97,27	0,184	0,176	215	0,2568047
17,483	543,3	544,2	95,77	97,83	0,184	0,176	216	0,2550794
17,650	543,4	544,2	94,70	96,74	0,184	0,176	217	0,257482
17,488	543,3	544,2	95,59	97,79	0,184	0,176	218	0,2550788
17,640	543,2	544,1	94,78	96,82	0,184	0,176	219	0,2574842
17,486	543,2	544,0	95,64	98,01	0,184	0,176	220	0,2550792
17,320	543,3	544,1	96,96	99,06	0,184	0,176	221	0,2522474
17,533	543,5	544,1	95,98	98,08	0,184	0,176	222	0,2550854
17,583	543,6	544,2	95,88	98,33	0,184	0,176	223	0,2554797
17,497	543,8	544,4	96,38	98,53	0,184	0,176	224	0,2540709
17,385	544,0	544,5	97,12	99,71	0,184	0,176	225	0,252246
17,805	544,2	544,7	94,94	96,99	0,184	0,176	226	0,2582552
17,474	544,4	544,8	96,53	98,87	0,184	0,176	227	0,2536666
17,625	544,5	544,9	95,50	97,90	0,184	0,176	228	0,2560826
17,475	544,5	545,0	96,18	98,43	0,184	0,176	229	0,2540565
17,562	544,4	545,0	95,68	97,90	0,184	0,176	230	0,2554814
17,601	544,4	545,0	95,46	97,46	0,184	0,176	231	0,256218
17,518	544,3	545,0	95,69	98,02	0,184	0,176	232	0,2550792
17,416	544,2	544,9	96,35	98,42	0,184	0,176	233	0,2536676
17,603	544,1	544,9	95,25	97,38	0,184	0,176	234	0,256483
17,615	544,1	544,8	95,16	97,16	0,184	0,176	235	0,2567012
17,494	544,0	544,8	95,87	98,09	0,184	0,176	236	0,2550797
17,562	543,9	544,7	95,25	97,43	0,184	0,176	237	0,2560832
17,858	543,8	544,7	93,71	95,81	0,184	0,176	238	0,2604902
17,573	543,7	544,6	95,23	97,29	0,184	0,176	239	0,2563338
17,368	543,7	544,5	96,31	98,46	0,184	0,176	240	0,2532668
17,555	543,7	544,5	95,19	97,52	0,184	0,176	241	0,2560794
17,419	543,6	544,5	96,13	98,25	0,184	0,176	242	0,2541022
17,482	543,6	544,4	95,71	97,93	0,184	0,176	243	0,2550791
17,690	543,5	544,4	94,62	96,56	0,184	0,176	244	0,2581132
17,547	543,5	544,4	95,42	97,48	0,184	0,176	245	0,2559835
17,639	543,5	544,4	94,95	96,92	0,184	0,176	246	0,2574122
17,571	543,5	544,3	95,21	97,29	0,185	0,176	247	0,2564838
17,398	543,5	544,3	96,15	98,47	0,184	0,176	248	0,2536673
17,512	543,6	544,4	95,76	97,89	0,184	0,176	249	0,2551067
17,593	543,7	544,5	95,47	97,61	0,184	0,176	250	0,2560874
17,616	543,9	544,6	95,41	97,62	0,184	0,176	251	0,2560825
17,661	544,1	544,7	95,50	97,88	0,184	0,176	252	0,2564909
17,378	544,3	544,8	97,13	99,28	0,184	0,176	253	0,2522478
17,669	544,4	545,0	95,51	97,82	0,184	0,176	254	0,2564834
17,556	544,5	545,1	95,97	97,90	0,184	0,176	255	0,2550797
17,528	544,6	545,1	95,92	98,07	0,184	0,176	256	0,2548344
17,764	544,6	545,2	94,47	96,83	0,184	0,176	257	0,2584623
17,322	544,5	545,1	96,83	99,06	0,184	0,176	258	0,2522487
17,509	544,4	545,1	95,78	97,94	0,184	0,176	259	0,2550801
17,508	544,3	545,0	95,64	97,88	0,184	0,176	260	0,2550803
17,632	544,2	545,0	94,91	97,16	0,184	0,176	261	0,257084
17,425	544,2	545,0	96,11	97,92	0,184	0,176	262	0,2541145
17,879	544,0	544,9	93,54	95,48	0,184	0,176	263	0,2608857
17,570	543,9	544,7	95,04	97,20	0,184	0,176	264	0,2564832
17,659	543,7	544,7	94,58	96,58	0,184	0,176	265	0,2578795
17,814	543,6	544,6	93,66	95,78	0,184	0,176	266	0,2602568
17,528	543,5	544,4	95,20	97,34	0,184	0,176	267	0,2560832
17,602	543,4	544,4	94,79	96,86	0,184	0,176	268	0,257084
17,637	543,3	544,3	94,68	96,67	0,184	0,176	269	0,2577277
17,441	543,2	544,2	95,70	97,76	0,184	0,176	270	0,2547977
17,528	543,2	544,1	95,39	97,22	0,185	0,176	271	0,2560832
17,458	543,2	544,1	95,50	97,80	0,184	0,176	272	0,2550793
17,450	543,2	544,1	95,70	97,83	0,184	0,176	273	0,2550795
17,481	543,2	544,1	95,49	97,45	0,185	0,176	274	0,255481
17,495	543,2	544,1	95,56	97,54	0,184	0,176	275	0,2554815
17,445	543,4	544,2	95,97	98,10	0,184	0,176	276	0,2544596
17,484	543,5	544,3	96,22	98,24	0,184	0,176	277	0,2546768
17,603	543,7	544,4	95,68	97,80	0,185	0,176	278	0,2560828
17,550	543,9	544,5	95,89	98,10	0,184	0,176	279	0,2550796
17,590	544,1	544,7	95,75	98,18	0,184	0,176	280	0,2554815
17,547	544,3	544,8	96,36	98,47	0,184	0,176	281	0,2546774
17,538	544,5	545,0	96,17	98,35	0,184	0,176	282	0,2546774
17,615	544,6	545,1	95,71	97,99	0,184	0,176	283	0,2560313
17,533	544,6	545,2	95,81	97,93	0,184	0,176	284	0,255048



17,619	544,7	545,3	95,26	97,37	0,184	0,176	285	0,2564858
17,547	544,6	545,3	95,56	97,57	0,184	0,176	286	0,2555407
17,577	544,6	545,3	95,46	97,60	0,184	0,176	287	0,2560748
17,642	544,6	545,3	94,99	97,03	0,184	0,176	288	0,2570845
17,637	544,5	545,3	94,92	97,03	0,184	0,176	289	0,2570854
17,495	544,5	545,2	95,69	97,63	0,184	0,176	290	0,2551061
17,681	544,4	545,2	94,66	96,64	0,184	0,176	291	0,2578821
17,579	544,3	545,1	95,13	97,33	0,184	0,176	292	0,2564863
17,551	544,3	545,1	95,29	97,32	0,184	0,176	293	0,2560853
17,645	544,2	545,1	94,88	97,06	0,184	0,176	294	0,2574843
17,543	544,1	545,0	95,26	97,30	0,184	0,176	295	0,2560854
17,470	544,1	545,0	95,43	97,76	0,184	0,176	296	0,2550823
17,657	544,1	545,0	94,54	96,59	0,184	0,176	297	0,2577353
17,571	544,1	545,0	95,06	97,22	0,184	0,176	298	0,2564855
17,498	544,0	544,9	95,34	97,51	0,184	0,176	299	0,2554284
17,496	544,0	544,9	95,58	97,63	0,184	0,176	300	0,2554836
17,474	544,0	544,8	95,59	97,46	0,184	0,176	301	0,2551647
17,539	543,9	544,8	95,28	97,26	0,184	0,176	302	0,2560856
17,399	543,9	544,8	96,08	98,01	0,184	0,176	303	0,2540746
17,602	543,9	544,8	94,71	96,97	0,184	0,176	304	0,2570645
17,471	543,9	544,7	95,51	97,89	0,184	0,176	305	0,2550811
17,464	543,9	544,7	95,66	97,70	0,184	0,176	306	0,2550821
17,560	543,8	544,7	95,09	97,16	0,184	0,176	307	0,2564858
17,627	543,8	544,7	94,68	96,73	0,184	0,176	308	0,2575208
17,594	543,8	544,7	94,86	97,03	0,184	0,176	309	0,2570399
17,555	543,8	544,7	94,93	97,14	0,184	0,176	310	0,2564855
17,617	543,7	544,6	94,68	96,70	0,184	0,176	311	0,2573874
17,647	543,7	544,6	94,42	96,58	0,184	0,176	312	0,2578817
17,444	543,8	544,6	95,77	97,95	0,184	0,176	313	0,2546781
17,563	543,9	544,7	95,24	97,35	0,184	0,176	314	0,2560876
17,589	544,1	544,8	95,32	97,81	0,184	0,176	315	0,2560882
17,444	544,3	544,9	96,42	98,67	0,184	0,176	316	0,2536724
17,722	544,4	545,1	95,22	96,99	0,184	0,176	317	0,2574842
17,639	544,6	545,3	95,40	97,49	0,184	0,175	318	0,2563098
17,568	544,8	545,4	95,73	97,89	0,184	0,176	319	0,2554845
17,855	544,9	545,5	94,02	96,20	0,184	0,176	320	0,2598654
17,645	544,8	545,5	94,92	97,14	0,184	0,176	321	0,2569903
17,698	544,8	545,5	94,65	96,75	0,184	0,176	322	0,2578836
17,502	544,8	545,5	95,77	97,86	0,184	0,176	323	0,2550874
17,562	544,7	545,4	95,17	97,44	0,184	0,176	324	0,256088
17,557	544,7	545,4	95,42	97,49	0,184	0,176	325	0,2560866
17,550	544,6	545,4	95,14	97,41	0,184	0,176	326	0,256086
17,505	544,6	545,4	95,30	97,68	0,184	0,176	327	0,255487

## APPENDIX 3: Calibration data

## Certificat d'Étalonnage / Certificate of Calibration

**CLIENT :**  
 SERVICES POLYTESTS INC.  
 695-B GAUDETTE  
 ST-JEAN-SUR-RICHELIEU, QUEBEC

**Description:** VÉRIFICATEUR D'HUMIDITÉ / MOISTURE METER  
**Fabricant/ Manufacturer:** DELMHORST  
**Modèle/ Model :** MCS-1 REFERENCE STANDARD  
**No série / Serial no :** N/A  
**# Inventaire / Asset # :** EM-191

**CERTIFICAT No / Certificate No:**      **254067**

**PROCÉDURE / Procedure :**  
 TRESCAL - DELMHORST\_MCS-1 REFERENCE STANDARD

**Date étalonnage/ Calibration Performed :**      **2018-12-19**  
aaaa - mm - jj

**Echéance/ Due Date :**      **2019-12-19**

Type de résultat / Results type :      **As-Found = As-Left**

**Conditions de mesure / Measurement conditions**

Résultats d'essais / Test results :      **Conforme / In Tolerance**

TEMPÉRATURE / Temp. :      **23.2°C**

Usage restreint/ Restricted use :     

HUMIDITÉ / Humidity :      **28% RH**

Réparation effectuée / Repair performed :     

Ajustement effectué / Adjustment performed :     

**ÉTALONS UTILISÉS/ Standards Used:**

Identification	Manuf.	Model	Description	Ser. #	Étalonné/ Cal.	Echéance/ Due
PR0661	FLUKE	8508A	REFERENCE MULTIMETER	389272208	2018-07-27	2019-07-27

Les spécifications mentionnées comme limites de tolérances d'essai sont celles établies par le manufacturier, sauf indication contraire.  
*Test tolerance limits are based on manufacturers specifications unless stated otherwise.*

**NOTES :**

2019.01.07

**Technicien :  
 Technician**

KOSTADINOV

Le système qualité de la société est conforme aux exigences de la norme ISO 17025 et les étalons utilisés pour le processus d'étalonnage sont retraçables au SI par l'entremise du CNRC et/ou du NIST.

*Our quality system complies with the requirements of ISO 17025 and the standards used for the calibration are traceable to SI through NRC and/or NIST.*  
LE DROIT D'AUTEUR DE CE CERTIFICAT APPARTIENT À TRESCAL / PRIMO INSTRUMENT INC. CE CERTIFICAT NE PEUT ÊTRE REPRODUIT AUTREMENT QU'EN ENTIER ET AVEC LE CONSENTEMENT PRÉALABLE ÉCRIT DU GROUPE TRESCAL.  
 TRESCAL / PRIMO INSTRUMENT INC. OWN COPYRIGHT OF THIS CERTIFICATE. THE CERTIFICATE MAY NOT BE REPRODUCED OTHER THAN IN FULL EXCEPT WITH THE PRIOR WRITTEN CONSENT OF THE TRESCAL GROUP.



CLIENT / Customer :

DESCRIPTION / Description :

MANUFACTURIER / Manufacturer :

MODÈLE / Model :

254067
SERVICES POLYTESTS INC.
VÉRIFICATEUR D'HUMIDITÉ / MOISTURE METER
DELMHORST
MCS-1 REFERENCE STANDARD

	DESCRIPTION Description	LIMITES Limits	LECTURES Readings	LIMITES Limits
<b>DOUGLAS-FIR @ 80°F</b>	Nominal			Déviaton Mohms
12 %	120 MOhms		115.1	4.9
22 %	1.10 MOhms		1.099	0.001



**Instrumentation  
Saint-Laurent** inc.  
Accrédité ISO 17025



80 rue de la montagne  
St-Joseph du lac  
(Québec), J0N 1M0  
Tél: (450) 473-6169  
Fax: (450) 473-5207  
Email: inst.st-laurent@videotron.ca

## CERTIFICAT D'ÉTALONNAGE

No.Certificat: CE-EM-006 06/03/19

CLIENT	
Compagnie:	Services Polytests Inc
Adresse:	695 B rue Gaudette St-Jean-sur-Richelieu, Québec, J3B 7S7

SPÉCIFICATION DE CALIBRATION	
Procédure de service:	4IN9106
Précision requise:	+/-0.25"H2O
Fréquence d'étalonnage: (jours)	365

SPÉCIFICATION DE L'INSTRUMENT			
Type d'instrument:	Indicateur	Type d'entrée:	Pression
Manufacturier:	Dwyer	Type de sortie:	Digitale
No. Model:	MS-321-LCD	Type de mesure:	Pression
No. Série:	E47U020014	Gamme:	0-0.5"H2O
Emplacement:	N.A.	No. Machine:	N.A.

SPÉCIFICATION DE L'ÉTALON			
Étalon Utilisé:	Setra	No. du certificat d'étalonnage:	2019001131
No. Série:	2784759	Dernière date d'étalonnage:	27-Feb-19
Certificat fait par:	Alpha Controls	Prochaine date d'étalonnage:	27-Feb-20
Commentaire:			

RÉSULTAT D'ÉTALONNAGE						
Entrée Source	Valeur Donnée	Valeur Actuelle	Erreur de Déviation	Valeur après Étalonnage	Incertitude Élargie	Commentaire
0.0000 "H2O	0.000 "H2O	0.000 "H2O	0.000 "H2O	0.000 "H2O	0.25 "H2O	Vérification indicateur
0.2500 "H2O	0.250 "H2O	0.249 "H2O	-0.001 "H2O	0.249 "H2O	0.25 "H2O	Vérification indicateur
0.5000 "H2O	0.500 "H2O	0.500 "H2O	0.000 "H2O	0.500 "H2O	0.25 "H2O	Vérification indicateur
0.7500 "H2O	0.750 "H2O	0.750 "H2O	0.000 "H2O	0.750 "H2O	0.25 "H2O	Vérification indicateur
1.0000 "H2O	1.000 "H2O	0.998 "H2O	-0.002 "H2O	0.998 "H2O	0.25 "H2O	Vérification indicateur
0.0000 "H2O	0.0000 V.DC.	0.0003 V.DC.	+0.0003 V.DC.	0.0003 V.DC.	0.5 V.DC.	Vérification sortie analogique
0.2500 "H2O	2.5000 V.DC.	2.4714 V.DC.	-0.0286 V.DC.	2.4714 V.DC.	0.5 V.DC.	Vérification sortie analogique
0.5000 "H2O	5.0000 V.DC.	5.0177 V.DC.	0.0177 V.DC.	5.0177 V.DC.	0.5 V.DC.	Vérification sortie analogique
0.7500 "H2O	7.5000 V.DC.	7.5058 V.DC.	0.0058 V.DC.	7.5058 V.DC.	0.5 V.DC.	Vérification sortie analogique
1.0000 "H2O	10.0000 V.DC.	9.9982 V.DC.	-0.0018 V.DC.	9.9982 V.DC.	0.5 V.DC.	Vérification sortie analogique
Conditions Environnementales:		Température:	19 °C	Humidité:	20 %RH	
Type d'Étalonnage:						

Instrumentation St-Laurent Inc. Certifie que l'instrument ci-haut, rencontre ou excède les spécifications établies par le fabricant. Le système qualité de l'entreprise est conforme aux exigences de la norme ISO 17025 et les étalons utilisés pour effectuer l'étalonnage est retraçable au CNRC et/ou au NIST. Le degré d'incertitude est basé sur un niveau de confiance=95%, K=2.

DATE D'ÉTALONNAGE / ÉMISSION DU CERTIFICAT	
Date d'Étalonnage:	6 Mars 2019
Date du prochain Étalonnage:	6 Mars 2020
Date d'émission du certificat:	6 Mars 2019

CONFORMITÉ D'ÉTALONNAGE		
	Avant	Après
Conforme:	X	X
Non Conforme:		

Le Service d'évaluation des laboratoires d'étalonnage (CLAS) du Conseil national de recherches du Canada (CNRC) a évalué et certifié la capacité d'étalonnage du laboratoire et la traçabilité au Système international d'unités (SI) ou à des étalons acceptables selon le CLAS. Le présent certificat d'étalonnage est délivré conformément aux conditions de certification du CLAS et aux conditions d'accréditation du Conseil canadien des normes (CCN). Numéro d'accréditation du CCN: # 669. Le CLAS et le CCN ne garantissent pas l'exactitude des étalonnages individuels effectués par les laboratoires accrédités.

*Martin Langlais*

Martin Langlais - Technicien

5F09106

Page 1 de 1

## CERTIFICAT D'ÉTALONNAGE

9900 Chemin de la Côte-de-Liesse, Lachine, QC H8T 1A1  
www.dispersion.ca 1.866.390.5066

<b>Client :</b>	Polytests	<b>No. du Certificat :</b>	152-4BB901-181
<b>Adresse :</b>	695 B rue Gaudette St-Jean-sur-Richelieu, QC J3B7S7	<b>Date d'étalonnage :</b>	09-01-2018

**Technicien:**  
Simeonidis, Georgios



David Llorens, Responsable Qualité

## DESCRIPTION DU SERVICE:

<b>Description des masses :</b>	ASTM E617	<b>Date d'approbation :</b>	09-01-2018
<b>Classe de précision :</b>	ASTM 6	<b>Date prochain étalonnage :</b>	09-01-2023
<b>Densité :</b>	7.95g/cm <sup>3</sup>	<b>Accréditation CCN n. :</b>	668
<b>Identification (si unique) :</b>	EM-090	<b>Certification CLAS n. :</b>	2010-01
<b>Condition d'essai :</b>	Temp °C: 21.17	Pression kPa: 101.475	Humidité: 48.665

## NOTES:

Pour l'étalonnage des masses, nous utilisons la procédure "Comparaison individuelle" PDL-09-MG-001 et la procédure "Détermination des incertitudes" PDL-09-MG-002. Le droit d'auteur du présent certificat appartient au laboratoire délivreur et doit être reproduit intégralement, à moins d'une autorisation écrite du laboratoire délivreur.

## REMARQUES:



11 JANV. 2018

page 1 de 5







## CERTIFICAT D'ÉTALONNAGE

9900 Chemin de la Côte-de-Liesse, Lachine, QC H8T 1A1  
www.dispersion.ca 1.866.390.5066

### BALANCES UTILISÉES

Pour l'étalonnage manuel :

> 5 kg à 25 kg :	Mettler Toledo XP32003L, SNR 1123271214, max. 32100 g, d = 0.005 g
> 1 kg à 5 kg	Mettler Toledo PR5003, SNR 1115311634, max. 5100 g, d = 0.001 g
> 300 g à 2 kg :	Mettler Toledo XP2004S, SNR B131185222, max. 2100 g, d = 0.1 mg
> 100 g à 200 g :	Mettler Toledo AT201 SNR BA1115230146, max. 205 g, d = 0.01 mg
> 5 g à 100 g :	Mettler Toledo AX106 SNR 1127063924, max. 111 g, d = 1 µg
1 mg à 5 g :	Mettler UMX5, SNR 1121103055, max. 5.1 g, d = 0.1 µg

Pour l'étalonnage automatisé :

> 200 g à 1 kg :	Mettler Toledo AX1005 SNR 1127063210, max. 1109 g, d = 0.01 mg
> 5 g à 100 g :	Mettler Toledo AX106 SNR 1120143015, max. 111 g, d = 1 µg
1 mg à 5 g :	Mettler UMX5, SNR 1125140561, max. 5.1 g, d = 0.1 µg

*Les balances sont vérifiées selon notre procédure de contrôle périodique PDL-11-MG-001.*

### INCERTITUDES:

Les incertitudes que nous retrouvons comprennent :

1. *L'incertitude associée à l'opération de pesage.*
2. *L'incertitude associée à la densité de l'air.*
3. *L'incertitude associée à l'étalon utilisé.*
4. *L'incertitude associée à la densité de la masse à être étalonnée.*

L'incertitude de l'opération de pesage comprend la reproductibilité à long terme.

Les incertitudes précisées dans ce rapport sont des incertitudes élargies représentant un niveau de confiance d'approximativement 95 %, obtenu en multipliant ensemble l'incertitude-type composée par un facteur de couverture de  $k = 2$ . Pour de plus amples renseignements, veuillez consulter la publication GUM (Guide pour l'expression de l'incertitude de mesure, édition de 1995).

### TRAÇABILITÉ

Le Service d'évaluation de laboratoires d'étalonnage (CLAS) du Conseil national de recherches du Canada (CNRC) a évalué et a certifié des capacités d'étalonnage spécifiques de ce laboratoire et leur traçabilité à des étalons nationaux de mesure reconnus et au Système international d'unités (SI). Ce certificat d'étalonnage est émis conformément aux conditions de certification accordées par CLAS et aux conditions d'accréditation accordées par le Conseil canadien des normes (CCN). Le CLAS pas plus que le CCN ne peut garantir l'exactitude des étalonnages individuels effectués par des laboratoires accrédités.

D.P

## CERTIFICAT D'ÉTALONNAGE

9900 Chemin de la Côte-de-Liesse, Lachine, QC H8T 1A1  
www.dispersion.ca 1.866.390.5066

### RÉFÉRENCES UTILISÉES

Poids	No de série	Fabricant	Date d'étalonnage	Date due
20kg	69976	Troemner	30-05-2017	30-05-2018
5kg	129099	Mettler Toledo	02-09-2017	02-09-2018
5kg	96-0888-50-3	Denver Instrument Company	02-09-2017	02-09-2018
2kg	129098	Mettler Toledo	02-09-2017	02-09-2018
2kg	96-0888-50-3	Denver Instrument Company	02-09-2017	02-09-2018
300g	96-0888-50-2	Denver Instrument Company	02-09-2017	02-09-2018
1kg - 1mg	MT-01	Mettler Toledo	02-09-2017	02-09-2018

### ÉTALONS CERTIFIÉS PAR LE CNRC( Référence NRC MS-2016-0021)

Poids	No de série	Fabricant	Date d'étalonnage	Date due
100g	95170	Mettler Toledo	17-10-2016	17-10-2018
10kg	129100	Mettler Toledo	17-10-2016	17-10-2018
1kg	95171	Mettler Toledo	17-10-2016	17-10-2018

### RÉFÉRENCES DE LA STATION ROBOTISÉE

Poids	No de série	Fabricant	Date d'étalonnage	Date due
1kg - 1mg	DK000A132	Laboratoire Dispersion	01-08-2017	01-08-2018

DP

## CERTIFICAT D'ÉTALONNAGE

9900 Chemin de la Côte-de-Liesse, Lachine, QC H8T 1A1  
www.dispersion.ca 1.866.390.5066

<b>Client :</b>	Polytests	<b>No. du Certificat :</b>	142-508805-181-2130
<b>Adresse :</b>	695 B rue Gaudette Saint-Jean-sur-Richelieu, QC J3B7S7	<b>Date d'étalonnage :</b>	28-05-2018

**Technicien:**  
Gatto, Angelo

David Llorens, Responsable Qualité

### DESCRIPTION DU SERVICE:

<b>Modèle de Balance :</b>	PA214	<b>Méthode :</b>	ISO 17025
<b>Manufacturier :</b>	Ohaus	<b>Date d'approbation :</b>	29-05-2018
<b>Numéro de Série :</b>	8331230529	<b>Date prochain étalonnage :</b>	28-05-2019
<b>Numéro d'identification :</b>	EM-232	<b>accréditation CCN n. :</b>	668
<b>Capacité :</b>	210g	<b>Certification CLAS n. :</b>	2010-01
<b>Résolution:</b>	0.0001g		

<b>Condition d'essai :</b>	<b>Temp °C:</b> 19	<b>Pression kPa:</b> 101.5	<b>Humidité %:</b> 62
----------------------------	--------------------	----------------------------	-----------------------

Note: Les conditions environnementales ne sont pas utilisées dans le calcul de l'incertitude.

### CETTE BALANCE RENCONTRE LES SPÉCIFICATIONS SUIVANTES:

Type de test :	Manufacturier
Excentricité:	<input checked="" type="checkbox"/> Oui <input type="checkbox"/> Non
Linéarité:	<input checked="" type="checkbox"/> Oui <input type="checkbox"/> Non
Sensibilité:	<input checked="" type="checkbox"/> Oui <input type="checkbox"/> Non
Répétabilité:	<input checked="" type="checkbox"/> Oui <input type="checkbox"/> Non

### NOTES:

Cette balance a été certifiée selon la procédure de travail PDL-09-MG-010 (certification de balance analytique et à plateau) et la et la procédure PDL-09-MG-012 (détermination des incertitudes de pesées). Nos étalons sont certifiés à chaque année. Le droit d'auteur du présent certificat appartient au laboratoire délivreur et doit être reproduit intégralement, à moins d'une autorisation écrite du laboratoire délivreur.

## CERTIFICAT D'ÉTALONNAGE

9900 Chemin de la Côte-de-Liesse, Lachine, QC H8T 1A1  
www.dispersion.ca 1.866.390.5066

<b>Client :</b>	Polytests	<b>No. du Certificat :</b>	142-508805-181-2130
<b>Adresse :</b>	695 B rue Gaudette Saint-Jean-sur-Richelieu, QC J3B7S7	<b>Accréditation CCN n. :</b>	668
<b>Méthode :</b>	ISO 17025	<b>Certification CLAS n. :</b>	2010-01
		<b>Modèle de Balance :</b>	PA214
		<b>Date d'étalonnage :</b>	28-05-2018
		<b>Date du prochain étalonnage :</b>	28-05-2019

### TEST D'EXCENTRICITÉ:

Poids Test: 50 g Tolérance 0.0003 g  
(Note: Le Poids Test est taré au centre du plateau de pesée)

Position	Avant Ajustement	Après Ajustement	
1: Centre:	0.0000 g	---	
2: Avant Gauche:	0.0001 g	---	
3: Arrière Gauche:	0.0000 g	---	
4: Arrière Droit:	0.0000 g	---	
5: Avant Droit:	0.0000 g	---	
<b>Résultats</b>	0.0001 g	---	
<b>STATUT</b>	<b>CONFORME</b>	<b>N/A</b>	

### TEST DE LINÉARITÉ:

Méthode: Substitution Plage: 210 g Poids Test: 50 g Tolérance: 0.0002 g

Pré-Charge	Avant Ajustement	Après Ajustement	
0.0000 g	50.0001 g	---	
50.0000 g	50.0001 g	---	
100.0000 g	50.0000 g	---	
150.0000 g	50.0001 g	---	
---	---	---	
---	---	---	
<b>Résultats</b>	0.00005 g	---	
<b>STATUT</b>	<b>CONFORME</b>	<b>N/A</b>	

### TEST DE SENSIBILITÉ:

Valeur de masse conventionnelle: 200.0002 g Tolérance: 0.0004 g Résultats: 0.00% < 0.10%

	Avant Ajustement	Après Ajustement	
<b>Lecture:</b>	200.0002 g	---	$S = \frac{\Delta W}{\Delta m}$
<b>Résultats:</b>	0.0000 g	---	
<b>STATUT</b>	<b>CONFORME</b>	<b>N/A</b>	

## CERTIFICAT D'ÉTALONNAGE

9900 Chemin de la Côte-de-Liesse, Lachine, QC H8T 1A1  
www.dispersion.ca 1.866.390.5066

<b>Client :</b>	Polytests	<b>No. du Certificat :</b>	142-508805-181-2130
<b>Adresse :</b>	695 B rue Gaudette Saint-Jean-sur-Richelieu, QC J3B7S7	<b>Accréditation CCN n. :</b>	668
<b>Méthode :</b>	ISO 17025	<b>Certification CLAS n. :</b>	2010-01
		<b>Modèle de Balance :</b>	PA214
		<b>Date d'étalonnage :</b>	28-05-2018
		<b>Date du prochain étalonnage :</b>	28-05-2019

### TEST DE RÉPÉTABILITÉ:

#### AVANT AJUSTEMENT:

Charge Utilisée:  
100.0000 g

Tolérance:  
0.00010 g

Résolution d'affichage:  
0.0001 g

Moyenne:  
100.00019 g

Écart-type:  
0.00003 g

#	Vide	Chargé	Différence
1	0.0000 g	100.0002 g	100.0002 g
2	0.0000 g	100.0001 g	100.0001 g
3	0.0000 g	100.0002 g	100.0002 g
4	0.0000 g	100.0002 g	100.0002 g
5	0.0000 g	100.0002 g	100.0002 g
6	0.0000 g	100.0002 g	100.0002 g
7	0.0000 g	100.0002 g	100.0002 g
8	0.0000 g	100.0002 g	100.0002 g
9	0.0000 g	100.0002 g	100.0002 g
10	0.0000 g	100.0002 g	100.0002 g

Statut : CONFORME

#### APRÈS AJUSTEMENT:

Charge Utilisée:  
---

Tolérance:  
0.00010 g

Résolution d'affichage:  
0.0001 g

Moyenne:  
---

Écart-type:  
---

#	Vide	Chargé	Différence
1	---	---	---
2	---	---	---
3	---	---	---
4	---	---	---
5	---	---	---
6	---	---	---
7	---	---	---
8	---	---	---
9	---	---	---
10	---	---	---

Statut : N/A

## CERTIFICAT D'ÉTALONNAGE

9900 Chemin de la Côte-de-Liesse, Lachine, QC H8T 1A1  
www.dispersion.ca 1.866.390.5066

### INCERTITUDE AVANT AJUSTEMENT :

$$U_c = \sqrt{(u_{(cr)})^2 + s_p^2 + u_{(l)}^2 + u_{(dr)}^2 + u_{(s)}^2}$$

- u(cr)** = Incertitude reliée à l'étalon utilisé
- Sp** = Incertitude de l'écart-type
- u(l)** = Incertitude associée à la linéarité
- u(dr)** = Incertitude associée à résolution si Sp = 0
- u(s)** = Incertitude liée à la sensibilité (span)

Valeur	Incertitude	Incertitude (%)
12.5000 g	0.00016 g	0.001285 %
25.0000 g	0.00016 g	0.000643 %
50.0000 g	0.00016 g	0.000324 %
100.0000 g	0.00017 g	0.000165 %
200.0000 g	0.00021 g	0.000104 %

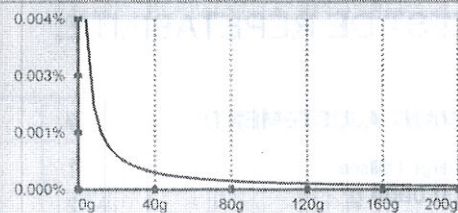

### INCERTITUDE APRÈS AJUSTEMENT :

Valeur	Incertitude	Incertitude (%)
---	---	---
---	---	---
---	---	---
---	---	---

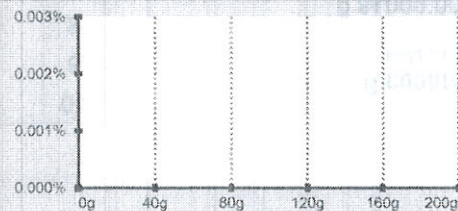

### NOTES :

De ces valeurs d'incertitudes, seule la valeur surlignée est calculée selon ISO17025:2005, les autres étant estimées jusqu'au résultat de l'incertitude minimale. Dans le calcul de cette l'incertitude, l'écart-type utilisé est de 0,577d (où d est la précision d'affichage de la balance) lorsque cet écart-type est plus inférieur à 0,577d.

## CERTIFICAT D'ÉTALONNAGE

9900 Chemin de la Côte-de-Liesse, Lachine, QC H8T 1A1  
www.dispersion.ca 1.866.390.5066

### RÉFÉRENCE

#### ENSEMBLE DE RÉFÉRENCE:

Référence	No de série	Fabricant	Date d'étalonnage
1mg-5kg	DK000A175	Dispersion	29-09-2017

### INCERTITUDES:

Les incertitudes que nous retrouvons comprennent :

1. *L'incertitude associée à l'opération de pesage.*
2. *L'incertitude associée à l'écart-type.*
3. *L'incertitude associée à l'étalon utilisé.*
4. *L'incertitude associée à la résolution de l'appareil.*

L'incertitude de l'opération de pesage comprend la reproductibilité à long terme.

Les incertitudes précisées dans ce rapport sont des incertitudes élargies représentant un niveau de confiance d'approximativement 95 %, obtenu en multipliant ensemble l'incertitude-type composée par un facteur de couverture de  $k = 2$ . Pour de plus amples renseignements, veuillez consulter la publication GUM (Guide pour l'expression de l'incertitude de mesure, édition de 1995).

### TRAÇABILITÉ

Le Service d'évaluation de laboratoires d'étalonnage (CLAS) du Conseil national de recherches du Canada (CNRC) a évalué et a certifié des capacités d'étalonnage spécifiques de ce laboratoire et leur traçabilité à des étalons nationaux de mesure reconnus et au Système international d'unités (SI). Ce certificat d'étalonnage est émis conformément aux conditions de certification accordées par CLAS et aux conditions d'accréditation accordées par le Conseil canadien des normes (CCN). Le CLAS pas plus que le CCN ne peut garantir l'exactitude des étalonnages individuels effectués par des laboratoires accrédités.

### REMARQUES:

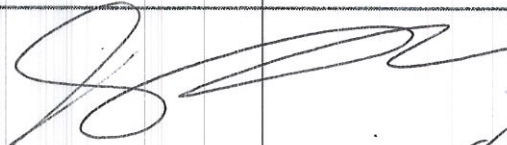
 18 Mai 2018
---



Ministère de la Santé  
 République du Congo

Ministère de la Santé  
 République du Congo

REMERCIEMENTS

REMERCIEMENTS

N°	Nom	Prénoms	Poste	Service

REMERCIEMENTS

Je tiens tout d'abord à remercier le Directeur Général de l'Institut National de Recherche Biomédicale (INRB) pour son accueil et son soutien. Je remercie également le Directeur de l'Unité de Recherche sur les Maladies Infectieuses et Parasitaires (URMIP) pour son accueil et son soutien. Je tiens aussi à remercier les membres de l'équipe de recherche pour leur accueil et leur soutien. Enfin, je tiens à remercier mes collègues pour leur accueil et leur soutien.

Je tiens également à remercier mes collègues pour leur accueil et leur soutien.

Je tiens également à remercier mes collègues pour leur accueil et leur soutien.

REMERCIEMENTS

Je tiens tout d'abord à remercier le Directeur Général de l'Institut National de Recherche Biomédicale (INRB) pour son accueil et son soutien. Je remercie également le Directeur de l'Unité de Recherche sur les Maladies Infectieuses et Parasitaires (URMIP) pour son accueil et son soutien. Je tiens aussi à remercier les membres de l'équipe de recherche pour leur accueil et leur soutien. Enfin, je tiens à remercier mes collègues pour leur accueil et leur soutien.

REMERCIEMENTS

*[Signature]*  
 [Nom et Prénoms]





## CERTIFICAT D'ÉTALONNAGE

No.Certificat: CE-EM-249 06/03/19

CLIENT	
Compagnie:	Services Polytests Inc
Adresse:	695 B rue Gaudette St-Jean-sur-Richelieu, Québec, J3B 7S7

SPÉCIFICATION DE CALIBRATION	
Procédure de service:	4IN9106
Précision requise:	+/- 0.25 "H2O
Fréquence d'étalonnage: (jours)	365

SPÉCIFICATION DE L'INSTRUMENT			
Type d'instrument:	Indicateur	Type d'entrée:	Pression
Manufacturier:	Dwyer	Type de sortie:	Voltage
No. Model:	MS-321-LCD	Type de mesure:	Pression
No. Série:	N/A	Gamme:	0 à 0.10 "H2O
Emplacement:	Banc de test	No. Machine:	N/A

SPÉCIFICATION DE L'ÉTALON			
Étalon Utilisé:	Setra	No. du certificat d'étalonnage:	2019001131
No. Série:	2784759	Dernière date d'étalonnage:	27-Feb-19
Certificat fait par:	Alpha Controls	Prochaine date d'étalonnage:	27-Feb-20

Commentaire:

### RÉSULTAT D'ÉTALONNAGE

Entrée Source	Valeur Donnée	Valeur Actuelle	Erreur de Déviation	Valeur après Étalonnage	Incertitude Élargie	Commentaire
0.0000 "H2O	0.0000 "H2O	-0.0002 "H2O	-0.0002 "H2O	0.0002 "H2O	0.25 "H2O	Vérification indicateur
0.0250 "H2O	0.0250 "H2O	0.0242 "H2O	-0.0008 "H2O	0.0242 "H2O	0.25 "H2O	Vérification indicateur
0.0500 "H2O	0.0500 "H2O	0.0491 "H2O	-0.0009 "H2O	0.0491 "H2O	0.25 "H2O	Vérification indicateur
0.0750 "H2O	0.0750 "H2O	0.0740 "H2O	-0.0010 "H2O	0.0740 "H2O	0.25 "H2O	Vérification indicateur
0.1000 "H2O	0.1000 "H2O	0.0981 "H2O	-0.0019 "H2O	0.0981 "H2O	0.25 "H2O	Vérification indicateur
0.0000 "H2O	0.0000 V.DC.	0.0006 V.DC.	+0.0006 V.DC.	0.0006 V.DC.	0.5 V.DC.	Vérification sortie analogique
0.0250 "H2O	2.5000 V.DC.	2.4262 V.DC.	-0.0738 V.DC.	2.4262 V.DC.	0.5 V.DC.	Vérification sortie analogique
0.0500 "H2O	5.0000 V.DC.	4.8990 V.DC.	-0.1010 V.DC.	4.8990 V.DC.	0.5 V.DC.	Vérification sortie analogique
0.0750 "H2O	7.5000 V.DC.	7.4021 V.DC.	-0.0979 V.DC.	7.4021 V.DC.	0.5 V.DC.	Vérification sortie analogique
0.1000 "H2O	10.0000 V.DC.	9.8114 V.DC.	-0.1886 V.DC.	9.8114 V.DC.	0.5 V.DC.	Vérification sortie analogique

Conditions Environnementales: Température: 19 °C Humidité: 16 %RH

Type d'Étalonnage:

Instrumentation St-Laurent Inc. Certifie que l'instrument ci-haut, rencontre ou excède les spécifications établies par le fabricant. Le système qualité de l'entreprise est conforme aux exigences de la norme ISO 17025 et les étalons utilisés pour effectuer l'étalonnage est traçable au CNRC et/ou au NIST. Le degré d'incertitude est basé sur un niveau de confiance=95%, K=2.

### DATE D'ÉTALONNAGE / ÉMISSION DU CERTIFICAT

Date d'Étalonnage:	6 Mars 2019
Date du prochain Étalonnage:	6 Mars 2020
Date d'émission du certificat:	6 Mars 2019

### CONFORMITÉ D'ÉTALONNAGE

	Avant	Après
Conforme:	X	X
Non Conforme:		

Le Service d'évaluation des laboratoires d'étalonnage (CLAS) du Conseil national de recherches du Canada (CNRC) a évalué et certifié la capacité d'étalonnage du laboratoire et la traçabilité au Système International d'unités (SI) ou à des étalons acceptables selon le CLAS. Le présent certificat d'étalonnage est délivré conformément aux conditions de certification du CLAS et aux conditions d'accréditation du Conseil canadien des normes (CCN). Numéro d'accréditation du CCN: # 669. Le CLAS et le CCN ne garantissent pas l'exactitude des étalonnages individuels effectués par les laboratoires accrédités.

Martin Langlais - Technicien

2019-03-19



**Instrumentation  
Saint-Laurent** inc.  
Accrédité ISO 17025



80 rue de la montagne  
St-Joseph du lac  
(Québec), J0N 1M0  
Tél: (450) 473-6169  
Fax: (450) 473-5207  
Email: inst.st-laurent@videotron.ca

## CERTIFICAT D'ÉTALONNAGE

No.Certificat: CE-EM-126 06/03/19

CLIENT	
Compagnie:	Services Polytests Inc
Adresse:	695 B rue Gaudette St-Jean-sur-Richelieu, Québec, J3B 7S7

SPÉCIFICATION DE CALIBRATION	
Procédure de service:	4IN9106
Précision requise:	+/- 1"Hg
Fréquence d'étalonnage: (jours)	365

SPÉCIFICATION DE L'INSTRUMENT			
Type d'instrument:	Manomètre	Type d'entrée:	Pression
Manufacturier:	Dwyer	Type de sortie:	Digitale
No. Model:	DPG200	Type de mesure:	Pression
No. Série:	N.A.	Gamme:	0-28"Hg
Emplacement:	N.A.	No. Machine:	N.A.

SPÉCIFICATION DE L'ÉTALON			
Étalon Utilisé:	Fluke 744	No. du certificat d'étalonnage:	2019000879
No. Série:	7798010	Dernière date d'étalonnage:	7-Feb-19
Certificat fait par:	Alpha Controls	Prochaine date d'étalonnage:	7-Feb-20
Commentaire:			

SPÉCIFICATION DE L'ÉTALON			
Étalon Utilisé:	Crystal XP2i	No. du certificat d'étalonnage:	2018004512
No. Série:	258139	Dernière date d'étalonnage:	9-Jul-18
Certificat fait par:	Alpha Controls	Prochaine date d'étalonnage:	9-Jul-19
Commentaire:			

RÉSULTAT D'ÉTALONNAGE						
Entrée Source	Valeur Donnée	Valeur Actuelle	Erreur de Déviation	Valeur après Étalonnage	Incertitude Élargie	Commentaire
0.00 "Hg	0.00 "Hg	0.00 "Hg	0.00 "Hg	0.00 "Hg	1 "Hg	Vérification indicateur
-7.50 "Hg	-7.50 "Hg	-7.61 "Hg	-0.11 "Hg	-7.61 "Hg	1 "Hg	Vérification indicateur
-15.00 "Hg	-15.00 "Hg	-15.25 "Hg	-0.25 "Hg	-15.25 "Hg	1 "Hg	Vérification indicateur
-22.50 "Hg	-22.50 "Hg	-22.88 "Hg	-0.38 "Hg	-22.88 "Hg	1 "Hg	Vérification indicateur
-28.00 "Hg	-28.00 "Hg	-28.48 "Hg	-0.48 "Hg	-28.48 "Hg	1 "Hg	Vérification indicateur
0.00 "Hg	10.0000 V.DC.	10.0625 V.DC.	+0.0625 V.DC.	10.0625 V.DC.	0.5 V.DC.	Vérification sortie analogique
-7.50 "Hg	8.0000 V.DC.	8.0413 V.DC.	+0.0413 V.DC.	8.0413 V.DC.	0.5 V.DC.	Vérification sortie analogique
-15.00 "Hg	6.0000 V.DC.	6.0055 V.DC.	+0.0055 V.DC.	6.0055 V.DC.	0.5 V.DC.	Vérification sortie analogique
-22.50 "Hg	4.0000 V.DC.	3.9621 V.DC.	-0.0379 V.DC.	3.9621 V.DC.	0.5 V.DC.	Vérification sortie analogique
-28.00 "Hg	2.5333 V.DC.	2.4497 V.DC.	-0.0836 V.DC.	2.4497 V.DC.	0.5 V.DC.	Vérification sortie analogique
Conditions Environnementales:			Température: 19 °C	Humidité: 16 %RH		
Type d'Étalonnage:						



**Instrumentation  
Saint-Laurent** inc.  
Accrédité ISO 17025



80 rue de la montagne  
St-Joseph du lac  
(Québec), J0N 1M0  
Tél: (450) 473-6169  
Fax: (450) 473-5207  
Email: inst.st-laurent@videotron.ca

## CERTIFICAT D'ÉTALONNAGE

No.Certificat: CE-EM-126 06/03/19

CLIENT	
Compagnie:	Services Polytests Inc
Adresse:	695 B rue Gaudette St-Jean-sur-Richelieu, Québec, J3B 7S7

SPÉCIFICATION DE CALIBRATION	
Procédure de service:	4IN9106
Précision requise:	+/- 1"Hg
Fréquence d'étalonnage: (jours)	365

SPÉCIFICATION DE L'INSTRUMENT			
Type d'instrument:	Manomètre	Type d'entrée:	Pression
Manufacturier:	Dwyer	Type de sortie:	Digitale
No. Model:	DPG200	Type de mesure:	Pression
No. Série:	N.A.	Gamme:	0-28"Hg
Emplacement:	N.A.	No. Machine:	N.A.

Instrumentation St-Laurent Inc. Certifie que l'instrument ci-haut, rencontre ou excède les spécifications établies par le fabricant. Le système qualité de l'entreprise est conforme aux exigences de la norme ISO 17025 et les étalons utilisés pour effectuer l'étalonnage est retraçable au CNRC et/ou au NIST. Le degré d'incertitude est basé sur un niveau de confiance=95%, K=2.

DATE D'ÉTALONNAGE / ÉMISSION DU CERTIFICAT	
Date d'Étalonnage:	6 Mars 2019
Date du prochain Étalonnage:	6 Mars 2020
Date d'émission du certificat:	6 Mars 2019

CONFORMITÉ D'ÉTALONNAGE		
	Avant	Après
Conforme:	X	X
Non Conforme:		

Le Service d'évaluation des laboratoires d'étalonnage (CLAS) du Conseil national de recherches du Canada (CNRC) a évalué et certifié la capacité d'étalonnage du laboratoire et la traçabilité au Système international d'unités (SI) ou à des étalons acceptables selon le CLAS. Le présent certificat d'étalonnage est délivré conformément aux conditions de certification du CLAS et aux conditions d'accréditation du Conseil canadien des normes (CCN). Numéro d'accréditation du CCN: # 669. Le CLAS et le CCN ne garantissent pas l'exactitude des étalonnages individuels effectués par les laboratoires accrédités.

Martin Langlais - Technicien



**Instrumentation  
Saint-Laurent** inc.  
Accrédité ISO 17025



80 rue de la montagne  
St-Joseph du lac  
(Québec), J0N 1M0  
Tél: (450) 473-6169  
Fax: (450) 473-5207  
Email: inst.st-laurent@videotron.ca

## CERTIFICAT D'ÉTALONNAGE

No.Certificat: CE-EM-127 06/03/19

CLIENT	
Compagnie:	Services Polytests Inc
Adresse:	695 B rue Gaudette St-Jean-sur-Richelieu, Québec, J3B 7S7

SPÉCIFICATION DE CALIBRATION	
Procédure de service:	4IN9106
Précision requise:	+/- 1"Hg
Fréquence d'étalonnage: (jours)	365

SPÉCIFICATION DE L'INSTRUMENT			
Type d'instrument:	Manomètre	Type d'entrée:	Pression
Manufacturier:	Dwyer	Type de sortie:	Digitale
No. Model:	DPG200	Type de mesure:	Pression
No. Série:	N.A.	Gamme:	0-28"Hg
Emplacement:	N.A.	No. Machine:	N.A.

SPÉCIFICATION DE L'ÉTALON			
Étalon Utilisé:	Fluke 744	No. du certificat d'étalonnage:	2019000879
No. Série:	7798010	Dernière date d'étalonnage:	7-Feb-19
Certificat fait par:	Alpha Controls	Prochaine date d'étalonnage:	7-Feb-20
Commentaire:			

SPÉCIFICATION DE L'ÉTALON			
Étalon Utilisé:	Crystal XP2i	No. du certificat d'étalonnage:	2018004512
No. Série:	258139	Dernière date d'étalonnage:	9-Jul-18
Certificat fait par:	Alpha Controls	Prochaine date d'étalonnage:	9-Jul-19
Commentaire:			

RÉSULTAT D'ÉTALONNAGE						
Entrée Source	Valeur Donnée	Valeur Actuelle	Erreur de Déviation	Valeur après Étalonnage	Incertitude Élargie	Commentaire
0.00 "Hg	0.00 "Hg	0.00 "Hg	0.00 "Hg	0.00 "Hg	1 "Hg	Vérification indicateur
-7.50 "Hg	-7.50 "Hg	-7.49 "Hg	+0.01 "Hg	-7.49 "Hg	1 "Hg	Vérification indicateur
-15.00 "Hg	-15.00 "Hg	-14.84 "Hg	+0.16 "Hg	-14.84 "Hg	1 "Hg	Vérification indicateur
-22.50 "Hg	-22.50 "Hg	-22.57 "Hg	-0.07 "Hg	-22.57 "Hg	1 "Hg	Vérification indicateur
-28.00 "Hg	-28.00 "Hg	-27.86 "Hg	+0.14 "Hg	-27.86 "Hg	1 "Hg	Vérification indicateur
0.00 "Hg	10.0000 V.DC.	10.0152 V.DC.	+0.0152 V.DC.	10.0152 V.DC.	0.5 V.DC.	Vérification sortie analogique
-7.50 "Hg	8.0000 V.DC.	8.0359 V.DC.	+0.0359 V.DC.	8.0359 V.DC.	0.5 V.DC.	Vérification sortie analogique
-15.00 "Hg	6.0000 V.DC.	6.0757 V.DC.	+0.0757 V.DC.	6.0757 V.DC.	0.5 V.DC.	Vérification sortie analogique
-22.50 "Hg	4.0000 V.DC.	3.9980 V.DC.	-0.0020 V.DC.	3.9980 V.DC.	0.5 V.DC.	Vérification sortie analogique
-28.00 "Hg	2.5333 V.DC.	2.5845 V.DC.	+0.0512 V.DC.	2.5845 V.DC.	0.5 V.DC.	Vérification sortie analogique
Conditions Environnementales:			Température: 19 °C	Humidité: 16 %RH		
Type d'Étalonnage:						

2019-03-19

5F09106



**Instrumentation  
Saint-Laurent** inc.  
Accrédité ISO 17025



80 rue de la montagne  
St-Joseph du lac  
(Québec), J0N 1M0  
Tél: (450) 473-6169  
Fax: (450) 473-5207  
Email: inst.st-laurent@videotron.ca

## CERTIFICAT D'ÉTALONNAGE

No.Certificat: CE-EM-127 06/03/19

CLIENT	
Compagnie:	Services Polytests Inc
Adresse:	695 B rue Gaudette St-Jean-sur-Richelieu, Québec, J3B 7S7

SPÉCIFICATION DE CALIBRATION	
Procédure de service:	4IN9106
Précision requise:	+/- 1"Hg
Fréquence d'étalonnage: (jours)	365

SPÉCIFICATION DE L'INSTRUMENT			
Type d'instrument:	Manomètre	Type d'entrée:	Pression
Manufacturier:	Dwyer	Type de sortie:	Digitale
No. Model:	DPG200	Type de mesure:	Pression
No. Série:	N.A.	Gamme:	0-28"Hg
Emplacement:	N.A.	No. Machine:	N.A.

Instrumentation St-Laurent Inc. Certifie que l'instrument ci-haut, rencontré ou excède les spécifications établies par le fabriquant. Le système qualité de l'entreprise est conforme aux exigences de la norme ISO 17025 et les étalons utilisés pour effectuer l'étalonnage est retraçable au CNRC et/ou au NIST. Le degré d'incertitude est basé sur un niveau de confiance=95%, K=2.

DATE D'ÉTALONNAGE / ÉMISSION DU CERTIFICAT	
Date d'Étalonnage:	6 Mars 2019
Date du prochain Étalonnage:	6 Mars 2020
Date d'émission du certificat:	6 Mars 2019

CONFORMITÉ D'ÉTALONNAGE		
	Avant	Après
Conforme:	X	X
Non Conforme:		

Le Service d'évaluation des laboratoires d'étalonnage (CLAS) du Conseil national de recherches du Canada (CNRC) a évalué et certifié la capacité d'étalonnage du laboratoire et la traçabilité au Système international d'unités (SI) ou à des étalons acceptables selon le CLAS. Le présent certificat d'étalonnage est délivré conformément aux conditions de certification du CLAS et aux conditions d'accréditation du Conseil canadien des normes (CCN). Numéro d'accréditation du CCN: # 669. Le CLAS et le CCN ne garantissent pas l'exactitude des étalonnages individuels effectués par les laboratoires accrédités.

Martin Langlais - Technicien

## CERTIFICAT D'ÉTALONNAGE

9900 Chemin de la Côte-de-Liesse, Lachine, QC H8T 1A1  
www.dispersion.ca 1.866.390.5066

<b>Client :</b>	Polytests	<b>No. du Certificat :</b>	152-4BB901-182
<b>Adresse :</b>	695 B rue Gaudette St-Jean-sur-Richelieu, QC J3B7S7	<b>Date d'étalonnage :</b>	09-01-2018

**Technicien:**  
Simeonidis, Georgios



David Llorens, Responsable Qualité

## DESCRIPTION DU SERVICE:

<b>Description des masses :</b>	ASTM E617	<b>Date d'approbation :</b>	09-01-2018
<b>Classe de précision :</b>	ASTM 1	<b>Date prochain étalonnage :</b>	09-01-2023
<b>Densité :</b>	7.95g/cm <sup>3</sup>	<b>Accréditation CCN n. :</b>	668
<b>Identification (si unique) :</b>	(items multiples)	<b>Certification CLAS n. :</b>	2010-01
<b>Condition d'essai :</b>	Temp °C: 21.265	Pression kPa: 101.565	Humidité: 49.58

## NOTES:

Pour l'étalonnage des masses, nous utilisons la procédure "Comparaison individuelle" PDL-09-MG-001 et la procédure "Détermination des incertitudes" PDL-09-MG-002. Le droit d'auteur du présent certificat appartient au laboratoire délivreur et doit être reproduit intégralement, à moins d'une autorisation écrite du laboratoire délivreur.

## REMARQUES:

  
11 JANV. 2018  
page 1 de 5







## CERTIFICAT D'ÉTALONNAGE

9900 Chemin de la Côte-de-Liesse, Lachine, QC H8T 1A1  
www.dispersion.ca 1.866.390.5066

### BALANCES UTILISÉES

Pour l'étalonnage manuel :

> 5 kg à 25 kg :	Mettler Toledo XP32003L, SNR 1123271214, max. 32100 g, d = 0.005 g
> 1 kg à 5 kg	Mettler Toledo PR5003, SNR 1115311634, max. 5100 g, d = 0.001 g
> 300 g à 2 kg :	Mettler Toledo XP2004S, SNR B131185222, max. 2100 g, d = 0.1 mg
> 100 g à 200 g :	Mettler Toledo AT201 SNR BA1115230146, max. 205 g, d = 0.01 mg
> 5 g à 100 g :	Mettler Toledo AX106 SNR 1127063924, max. 111 g, d = 1 µg
1 mg à 5 g :	Mettler UMX5, SNR 1121103055, max. 5.1 g, d = 0.1 µg

Pour l'étalonnage automatisé :

> 200 g à 1 kg :	Mettler Toledo AX1005 SNR 1127063210, max. 1109 g, d = 0.01 mg
> 5 g à 100 g :	Mettler Toledo AX106 SNR 1120143015, max. 111 g, d = 1 µg
1 mg à 5 g :	Mettler UMX5, SNR 1125140561, max. 5.1 g, d = 0.1 µg

Les balances sont vérifiées selon notre procédure de contrôle périodique PDL-11-MG-001.

### INCERTITUDES:

Les incertitudes que nous retrouvons comprennent :

1. L'incertitude associée à l'opération de pesage.
2. L'incertitude associée à la densité de l'air.
3. L'incertitude associée à l'étalon utilisé.
4. L'incertitude associée à la densité de la masse à être étalonnée.

L'incertitude de l'opération de pesage comprend la reproductibilité à long terme.

Les incertitudes précisées dans ce rapport sont des incertitudes élargies représentant un niveau de confiance d'approximativement 95 %, obtenu en multipliant ensemble l'incertitude-type composée par un facteur de couverture de  $k = 2$ . Pour de plus amples renseignements, veuillez consulter la publication GUM (Guide pour l'expression de l'incertitude de mesure, édition de 1995).

### TRAÇABILITÉ

Le Service d'évaluation de laboratoires d'étalonnage (CLAS) du Conseil national de recherches du Canada (CNRC) a évalué et a certifié des capacités d'étalonnage spécifiques de ce laboratoire et leur traçabilité à des étalons nationaux de mesure reconnus et au Système international d'unités (SI). Ce certificat d'étalonnage est émis conformément aux conditions de certification accordées par CLAS et aux conditions d'accréditation accordées par le Conseil canadien des normes (CCN). Le CLAS pas plus que le CCN ne peut garantir l'exactitude des étalonnages individuels effectués par des laboratoires accrédités.



## CERTIFICAT D'ÉTALONNAGE

9900 Chemin de la Côte-de-Liesse, Lachine, QC H8T 1A1  
www.dispersion.ca 1.866.390.5066

### RÉFÉRENCES UTILISÉES

Poids	No de série	Fabricant	Date d'étalonnage	Date due
20kg	69976	Troemner	30-05-2017	30-05-2018
5kg	129099	Mettler Toledo	02-09-2017	02-09-2018
5kg	96-0888-50-3	Denver Instrument Company	02-09-2017	02-09-2018
2kg	129098	Mettler Toledo	02-09-2017	02-09-2018
2kg	96-0888-50-3	Denver Instrument Company	02-09-2017	02-09-2018
300g	96-0888-50-2	Denver Instrument Company	02-09-2017	02-09-2018
1kg - 1mg	MT-01	Mettler Toledo	02-09-2017	02-09-2018

### ÉTALONS CERTIFIÉS PAR LE CNRC( Référence NRC MS-2016-0021)

Poids	No de série	Fabricant	Date d'étalonnage	Date due
100g	95170	Mettler Toledo	17-10-2016	17-10-2018
10kg	129100	Mettler Toledo	17-10-2016	17-10-2018
1kg	95171	Mettler Toledo	17-10-2016	17-10-2018

### RÉFÉRENCES DE LA STATION ROBOTISÉE

Poids	No de série	Fabricant	Date d'étalonnage	Date due
1kg - 1mg	DK000A132	Laboratoire Dispersion	01-08-2017	01-08-2018

*D.P.*



**Instrumentation  
Saint-Laurent** inc.  
Accrédité ISO 17025



80 rue de la montagne  
St-Joseph du lac  
(Québec), J0N 1M0  
Tél: (450) 473-6169  
Fax: (450) 473-5207  
Email: inst.st-laurent@videotron.ca

## CERTIFICAT D'ÉTALONNAGE

No.Certificat: CE-EM-001 06/03/19

CLIENT	
Compagnie:	Services Polytests Inc
Adresse:	695 B rue Gaudette
	St-Jean-sur-Richelieu, Québec, J3B 7S7

SPÉCIFICATION DE CALIBRATION	
Procédure de service:	4IN9101
Précision requise:	+/- 2.0°C
Fréquence d'étalonnage: (jours)	365

SPÉCIFICATION DE L'INSTRUMENT			
Type d'instrument:	Indicateur	Type d'entrée:	Temp
Manufacturier:	Fluke	Type de sortie:	Digitale
No. Model:	52-II	Type de mesure:	Température
No. Série:	90630037	Gamme:	Divers
Emplacement:	N.A.	No. Machine:	N.A.

SPÉCIFICATION DE L'ÉTALON			
Étalon Utilisé:	Fluke 744	No. du certificat d'étalonnage:	2019000879
No. Série:	7798010	Dernière date d'étalonnage:	7-Feb-19
Certificat fait par:	Alpha Controls	Prochaine date d'étalonnage:	7-Feb-20

Commentaire:

RÉSULTAT D'ÉTALONNAGE						
Entrée Source	Valeur Donnée	Valeur Actuelle	Erreur de Déviation	Valeur après Étalonnage	Incertitude Élargie	Commentaire
0.0 °C	0.0 °C	0.0 °C	0.0 °C	0.0 °C	1.0 °C	T1 typeJ
125.0 °C	125.0 °C	125.1 °C	+0.1 °C	125.1 °C	1.0 °C	T1 typeJ
250.0 °C	250.0 °C	250.1 °C	+0.1 °C	250.1 °C	1.0 °C	T1 typeJ
375.0 °C	375.0 °C	375.1 °C	+0.1 °C	375.1 °C	1.0 °C	T1 typeJ
500.0 °C	500.0 °C	500.1 °C	+0.1 °C	500.1 °C	1.0 °C	T1 typeJ
0.0 °C	0.0 °C	0.2 °C	+0.2 °C	0.2 °C	1.0 °C	T2 typeJ
125.0 °C	125.0 °C	125.1 °C	+0.1 °C	125.1 °C	1.0 °C	T2 typeJ
250.0 °C	250.0 °C	250.1 °C	+0.1 °C	250.1 °C	1.0 °C	T2 typeJ
375.0 °C	375.0 °C	375.1 °C	+0.1 °C	375.1 °C	1.0 °C	T2 typeJ
500.0 °C	500.0 °C	500.1 °C	+0.1 °C	500.1 °C	1.0 °C	T2 typeJ
0.0 °C	0.0 °C	0.2 °C	+0.2 °C	0.2 °C	1.0 °C	T1 typeK
125.0 °C	125.0 °C	125.2 °C	+0.2 °C	125.2 °C	1.0 °C	T1 typeK
250.0 °C	250.0 °C	250.1 °C	+0.1 °C	250.1 °C	1.0 °C	T1 typeK
375.0 °C	375.0 °C	375.2 °C	+0.2 °C	375.2 °C	1.0 °C	T1 typeK
500.0 °C	500.0 °C	500.1 °C	+0.1 °C	500.1 °C	1.0 °C	T1 typeK
0.0 °C	0.0 °C	0.2 °C	+0.2 °C	0.2 °C	1.0 °C	T2 typeK
125.0 °C	125.0 °C	125.2 °C	+0.2 °C	125.2 °C	1.0 °C	T2 typeK
250.0 °C	250.0 °C	250.2 °C	+0.2 °C	250.2 °C	1.0 °C	T2 typeK
375.0 °C	375.0 °C	375.2 °C	+0.2 °C	375.2 °C	1.0 °C	T2 typeK
500.0 °C	500.0 °C	500.2 °C	+0.2 °C	500.2 °C	1.0 °C	T2 typeK

Conditions Environnementales: Température: 19 °C Humidité: 16 %RH

Type d'Étalonnage:

5F09101

## CERTIFICAT D'ÉTALONNAGE

No.Certificat: CE-EM-001 06/03/19

CLIENT	
Compagnie:	Services Polytests Inc
Adresse:	695 B rue Gaudette St-Jean-sur-Richelieu, Québec, J3B 7S7

SPÉCIFICATION DE CALIBRATION	
Procédure de service:	4IN9101
Précision requise:	+/- 2.0°C
Fréquence d'étalonnage: (jours)	365

SPÉCIFICATION DE L'INSTRUMENT			
Type d'instrument:	Indicateur	Type d'entrée:	Temp
Manufacturier:	Fluke	Type de sortie:	Digitale
No. Model:	52-II	Type de mesure:	Température
No. Série:	90630037	Gamme:	Divers
Emplacement:	N.A.	No. Machine:	N.A.

Instrumentation St-Laurent Inc. Certifie que l'instrument ci-haut, rencontre ou excède les spécifications établies par le fabricant. Le système qualité de l'entreprise est conforme aux exigences de la norme ISO 17025 et les étalons utilisés pour effectuer l'étalonnage est retraceable au CNRC et/ou au NIST. Le degré d'incertitude est basé sur un niveau de confiance=95%, K=2.

DATE D'ÉTALONNAGE / ÉMISSION DU CERTIFICAT	
Date d'Étalonnage:	6 Mars 2019
Date du prochain Étalonnage:	6 Mars 2020
Date d'émission du certificat:	6 Mars 2019

CONFORMITÉ D'ÉTALONNAGE		
	Avant	Après
Conforme:	X	X
Non Conforme:		

Le Service d'évaluation des laboratoires d'étalonnage (CLAS) du Conseil national de recherches du Canada (CNRC) a évalué et certifié la capacité d'étalonnage du laboratoire et la traçabilité au Système international d'unités (SI) ou à des étalons acceptables selon le CLAS. Le présent certificat d'étalonnage est délivré conformément aux conditions de certification du CLAS et aux conditions d'accréditation du Conseil canadien des normes (CCN). Numéro d'accréditation du CCN: # 669. Le CLAS et le CCN ne garantissent pas l'exactitude des étalonnages individuels effectués par les laboratoires accrédités.

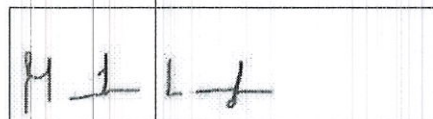

Martin Langlais - Technicien

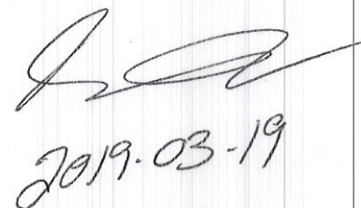



**Instrumentation  
Saint-Laurent** Inc.  
Accrédité ISO 17025

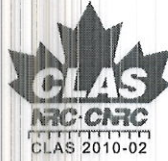

80 rue de la montagne  
St-Joseph du lac  
(Québec), J0N 1M0  
Tél: (450) 473-6169  
Fax: (450) 473-5207  
Email: inst.st-laurent@videotron.ca

## CERTIFICAT D'ÉTALONNAGE

No.Certificat: CE-EM-015 05/03/19

CLIENT	
Compagnie:	Services Polytests Inc
Adresse:	695 B rue Gaudette St-Jean-sur-Richelieu, Québec, J3B 7S7

SPÉCIFICATION DE CALIBRATION	
Procédure de service:	4IN9101
Précision requise:	+/- 2°C
Fréquence d'étalonnage: (jours)	365

SPÉCIFICATION DE L'INSTRUMENT			
Type d'instrument:	Enregistreur	Type d'entrée:	Temp
Manufacturier:	Keithley	Type de sortie:	Digitale
No. Model:	7700	Type de mesure:	Température
No. Série:	1213648	Gamme:	Divers
Emplacement:	N/A	No. Machine:	N.A.

SPÉCIFICATION DE L'ÉTALON			
Étalon Utilisé:	Fluke 744	No. du certificat d'étalonnage:	2019000879
No. Série:	7798010	Dernière date d'étalonnage:	7-Feb-19
Certificat fait par:	Alpha Controls	Prochaine date d'étalonnage:	7-Feb-20
Commentaire:			

RÉSULTAT D'ÉTALONNAGE						
Entrée Source	Valeur Donnée	Valeur Actuelle	Erreur de Déviation	Valeur après Étalonnage	Incertitude Élargie	Commentaire
-190.0 °C	-190.0 °C	-190.7 °C	-0.7 °C	-190.7 °C	1.0 °C	Input#1TypeK
0.0 °C	0.0 °C	-0.3 °C	-0.3 °C	-0.3 °C	1.0 °C	Input#1TypeK
750.0 °C	750.0 °C	749.8 °C	-0.2 °C	749.8 °C	1.0 °C	Input#1TypeK
100.0 °C	100.0 °C	99.7 °C	-0.3 °C	99.7 °C	1.0 °C	Input#2 TypeK
100.0 °C	100.0 °C	99.7 °C	-0.3 °C	99.7 °C	1.0 °C	Input#3 TypeK
100.0 °C	100.0 °C	99.7 °C	-0.3 °C	99.7 °C	1.0 °C	Input#4 TypeK
100.0 °C	100.0 °C	99.7 °C	-0.3 °C	99.7 °C	1.0 °C	Input#5TypeK
100.0 °C	100.0 °C	99.8 °C	-0.2 °C	99.8 °C	1.0 °C	Input#6TypeK
100.0 °C	100.0 °C	99.9 °C	-0.1 °C	99.9 °C	1.0 °C	Input#7TypeK
100.0 °C	100.0 °C	99.8 °C	-0.2 °C	99.8 °C	1.0 °C	Input#8TypeK
100.0 °C	100.0 °C	99.8 °C	-0.2 °C	99.8 °C	1.0 °C	Input#9TypeK
100.0 °C	100.0 °C	99.9 °C	-0.1 °C	99.9 °C	1.0 °C	Input#10TypeJ
100.0 °C	100.0 °C	99.8 °C	-0.2 °C	99.8 °C	1.0 °C	Input#11TypeJ
100.0 °C	100.0 °C	99.9 °C	-0.1 °C	99.9 °C	1.0 °C	Input#12TypeJ
100.0 °C	100.0 °C	99.9 °C	-0.1 °C	99.9 °C	1.0 °C	Input#13 TypeJ
100.0 °C	100.0 °C	99.9 °C	-0.1 °C	99.9 °C	1.0 °C	Input#14TypeJ
100.0 °C	100.0 °C	100.0 °C	0.0 °C	100.0 °C	1.0 °C	Input#15 TypeJ
100.0 °C	100.0 °C	99.9 °C	-0.1 °C	99.9 °C	1.0 °C	Input#16TypeJ
100.0 °C	100.0 °C	100.0 °C	0.0 °C	100.0 °C	1.0 °C	Input#17TypeJ
100.0 °C	100.0 °C	99.9 °C	-0.1 °C	99.9 °C	1.0 °C	Input#18TypeJ
100.0 °C	100.0 °C	100.0 °C	0.0 °C	100.0 °C	1.0 °C	Input#19TypeJ
100.0 °C	100.0 °C	100.1 °C	+0.1 °C	100.1 °C	1.0 °C	Input#20TypeJ
12.000 mA	12.000 mA	12.003 mA	+0.003 mA	12.003 mA	1.00 mA	Input#21
12.000 mA	12.000 mA	12.003 mA	+0.003 mA	12.003 mA	1.00 mA	Input#22
Conditions Environnementales: Température: 19 °C Humidité: 20 %RH						

5F09101



## CERTIFICAT D'ÉTALONNAGE

No.Certificat: CE-EM-015 05/03/19

CLIENT	
Compagnie:	Services Polytests Inc
Adresse:	695 B rue Gaudette
	St-Jean-sur-Richelieu, Québec, J3B 7S7

SPÉCIFICATION DE CALIBRATION	
Procédure de service:	4IN9101
Précision requise:	+/- 2°C
Fréquence d'étalonnage: (jours)	365

SPÉCIFICATION DE L'INSTRUMENT			
Type d'instrument:	Enregistreur	Type d'entrée:	Temp
Manufacturier:	Keithley	Type de sortie:	Digitale
No. Model:	7700	Type de mesure:	Température
No. Série:	1213648	Gamme:	Divers
Emplacement:	N/A	No. Machine:	N.A.

Type d'Étalonnage: Test avec EM-147

Instrumentation St-Laurent Inc. Certifie que l'instrument ci-haut, rencontre ou excède les spécifications établies par le fabriquant. Le système qualité de l'entreprise est conforme aux exigences de la norme ISO 17025 et les étalons utilisés pour effectuer l'étalonnage est retraçable au CNRC et/ou au NIST. Le degré d'incertitude est basé sur un niveau de confiance=95%, K=2.

DATE D'ÉTALONNAGE / ÉMISSION DU CERTIFICAT	
Date d'Étalonnage:	5 Mars 2019
Date du prochain Étalonnage:	5 Mars 2020
Date d'émission du certificat:	5 Mars 2019

CONFORMITÉ D'ÉTALONNAGE		
	Avant	Après
Conforme:	X	X
Non Conforme:		

Le Service d'évaluation des laboratoires d'étalonnage (CLAS) du Conseil national de recherches du Canada (CNRC) a évalué et certifié la capacité d'étalonnage du laboratoire et la traçabilité au Système international d'unités (SI) ou à des étalons acceptables selon le CLAS. Le présent certificat d'étalonnage est délivré conformément aux conditions de certification du CLAS et aux conditions d'accréditation du Conseil canadien des normes (CCN). Numéro d'accréditation du CCN: # 669. Le CLAS et le CCN ne garantissent pas l'exactitude des étalonnages individuels effectués par les laboratoires accrédités.

*M L L*

Martin Langlais - Technicien

*[Signature]*  
2019.03.09

**CERTIFICAT D'ÉTALONNAGE # 9786**

Date d'étalonnage : 2018-11-12

Date d'émission du certificat : 2018-11-12

Services Polytests  
695 B Gaudette street  
St-Jean-sur-Richelieu, Québec, Canada  
J3B 7S7

Étalonnage d'un  
Débitmètre volumétrique American Meter Company DTM-200A S/N : 99A274209

**CONFORMITÉ AU PROGRAMME DE QUALITÉ**

Tous les étalonnages sont effectués conformément au manuel d'assurance qualité de Polycontrols qui est conforme à la norme ISO/IEC 17025 – 2005, à la norme ISO 9001 – 2015 ainsi qu'à tout autre exigences de qualité définies dans la description d'achat des clients.

**TRAÇABILITÉ**

La traçabilité des étalons de débit au National Institute of Standards and Technology, NIST, est maintenue par les laboratoires de Fluke Corporation de Phoenix, Arizona et est conforme aux normes ISO/IEC 17025, AINSI/NCSL Z540-1-1994, ISO-10012-1, MIL-STD 45662A.

Le Service d'évaluation des laboratoires d'étalonnage (CLAS) du Conseil national de recherches du Canada (CNRC) a évalué et certifié la capacité d'étalonnage du laboratoire et la traçabilité au Système international d'unités (SI) ou à des étalons acceptables selon le CLAS. Le présent certificat d'étalonnage est délivré conformément aux conditions de certification du CLAS et aux conditions d'accréditation du Conseil canadien des normes (CCN). Le CLAS et le CCN ne garantissent pas l'exactitude des étalonnages individuels effectués par les laboratoires accrédités.

**APTITUDE EN MATIÈRE DE MESURE ET D'ÉTALONNAGE - CMC**

Les références utilisées pour l'étalonnage de débit ont une incertitude de  $\pm 0.2\%$  de la lecture pour les mesures entre 5 SCCM à 10 SLPM,  $\pm 0.3\%$  de la lecture pour les mesures entre 10 SLPM à 30 SLPM,  $\pm 0.2\%$  de la lecture pour les mesures entre 30 SLPM à 3000 SLPM,  $\pm 0.3\%$  de la lecture pour les mesures supérieures à 3000 SLPM jusqu'à 6000 SLPM et  $\pm 0.5\%$  pour les mesures inférieures à 5 SCCM jusqu'à concurrence de 1 SCCM, équivalent air ou azote. Les incertitudes exprimées sont élargies avec un facteur d'élargissement  $k = 2$ , et ce, pour un niveau de confiance d'environ 95 %, dans l'hypothèse d'une distribution normale incluant la résolution de l'instrument. Le rapport d'incertitude des essais (RIE) de cet étalonnage respecte un ratio de 4:1 à moins d'indication contraire.

**SOMMAIRE DES CONDITIONS DE L'INSTRUMENT EN TEST**

Conditions initiales	En bon état
Travail Effectué	Étalonnage de l'instrument
Résultats	Lectures Initiales = Lectures finales, aucun ajustement
Remarques	Lectures finales dans les tolérances
	Fréquence d'étalonnage aux 12 mois

  
Métrologue

  
Responsable du laboratoire

2018-11-22

**Certificat d'étalonnage # 9786**

Numéro de série:	99A274209	Station de mesure:	3
Date d'étalonnage:	2018-11-12	Procédure:	POS-CAL-005
Identification de l'instrument:	EM-130		

**Instrument de mesure de référence utilisé pour l'étalonnage final**

Description	Modèle	# Série	Traçabilité	Date dû
DHI molbloc (30 slpm)	3E4-VCR-V-Q	2403	1500237464	2019-04-26
DHI molbloc (100 slpm)	2E2-S	380	1500241926	2019-07-19
DHI molbox1	Molbox1	755	1500237197	2019-04-25
RTD Mist	M22	2208102	2018002234	2019-04-11
Module 44.5 PSI avec Baro 163671	Module 30	160659	2018002180	2019-04-12

**Spécifications finales de l'appareil**

**Condition d'étalonnage**

Gaz	Air	Gaz	Air
Température d'opération		Température ambiante	21.5 °C
Pression à l'entrée		Pression ambiante	1026.07 mbar
Pression à la sortie		Orientation	Verticale
Température de référence		Élastomère	Viton
Pression de référence		Valve	Viton
Étendue d'échelle	0-200 ACFH		
Signaux Entrée/Sortie	-		
Alimentation			
Tolérance	±1 %O.R.		

**Lectures finales**

Débit du test ACFH	Instrument en test ft <sup>3</sup>	Valeurs mesurées			Référence calculée ft <sup>3</sup>	Erreur calculée ft <sup>3</sup>	Tolérance acceptable ft <sup>3</sup>	TUR
		Pression PSIA	Température °C	Référence ft <sup>3</sup>				
39.5798	6.610	14.8845	21.17	6.674	6.590	0.020	0.066	2.97
70.0656	11.700	14.9044	21.05	11.845	11.677	0.023	0.117	>4
164.1928	27.340	15.0230	20.96	27.959	27.336	0.004	0.273	>4

Bernard Poirier  
Métrologue

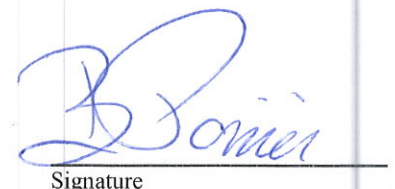

Signature



## Certificat d'étalonnage # 9786

Numéro de série:	99A274209	Station de mesure:	3
Date d'étalonnage:	2018-11-12	Procédure:	POS-CAL-005
Identification de l'instrument:	EM-130		

## Résultats finaux

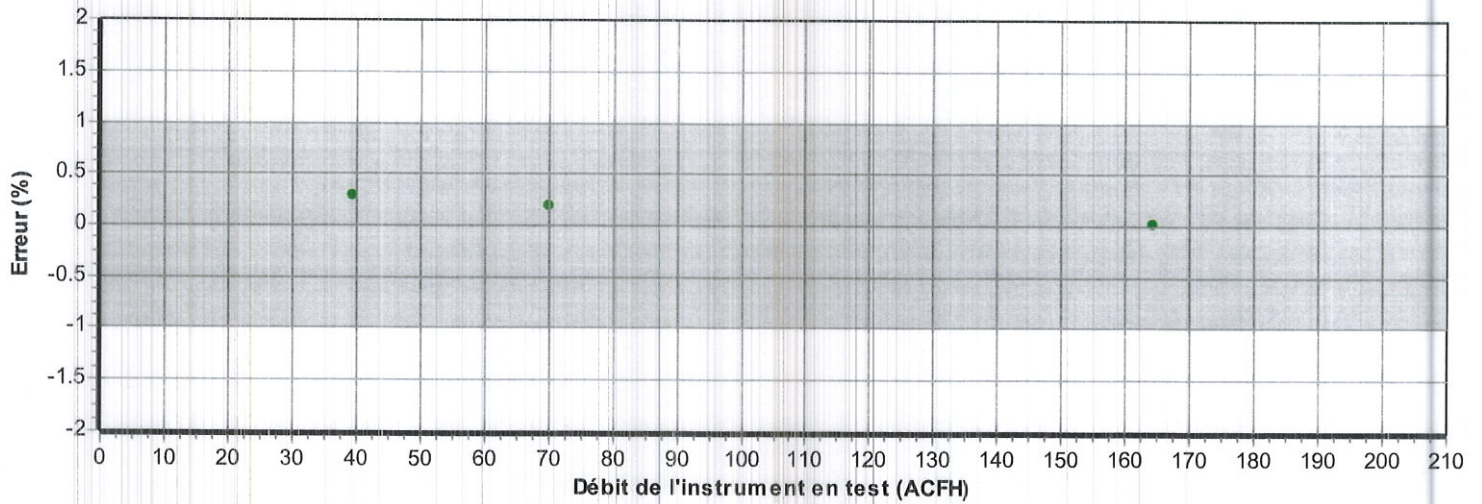

- La mesure (et son incertitude) se situe dans les tolérances
- La mesure (et son incertitude) se situe hors tolérance
- La mesure (et son incertitude) ne rencontre pas la marge de sécurité tel que spécifié dans le document G-8 de l'ILAC

Bernard Poirier  
Métrologue

  
Signature

## CERTIFICAT D'ÉTALONNAGE

No.Certificat: CE-EM-136 09/03/19

CLIENT	
Compagnie:	Services Polytests Inc
Adresse:	695 B rue Gaudette St-Jean-sur-Richelieu, Québec, J3B 7S7

SPÉCIFICATION DE CALIBRATION	
Procédure de service:	ISL-004
Précision requise:	+/-2°C +/-3%RH
Fréquence d'étalonnage: (jours)	365

SPÉCIFICATION DE L'INSTRUMENT			
Type d'instrument:	Hygromètre	Type d'entrée:	Temp/%RH
Manufacturier:	Fluke	Type de sortie:	Digitale
No. Model:	971	Type de mesure:	Temp/humidité
No. Série:	10610850	Gamme:	5-95%RH -20a60°C
Emplacement:	N.A.	No. Machine:	N.A.

SPÉCIFICATION DE L'ÉTALON			
Étalon Utilisé:	Vaisala HMI14/HMP46	No. du certificat d'étalonnage:	2018002178
No. Série:	T1450150/T1940011	Dernière date d'étalonnage:	10-Apr-18
Certificat fait par:	Alpha Controls	Prochaine date d'étalonnage:	10-Apr-19
Commentaire:			

RÉSULTAT D'ÉTALONNAGE						
Entrée Source	Valeur Donnée	Valeur Actuelle	Erreur de Déviation	Valeur après Étalonnage	Incertitude Élargie	Commentaire
25.0 °C	25.0 °C	25.2 °C	+0.2 °C	25.2 °C	1.0 °C	
40.0 °C	40.0 °C	40.2 °C	+0.2 °C	40.2 °C	1.0 °C	
28.0 %RH	28.2 %RH	29.0 %RH	+0.8 %RH	29.0 %RH	-- %RH	
48.0 %RH	48.1 %RH	49.3 %RH	+1.2 %RH	49.3 %RH	-- %RH	
75.0 %RH	74.7 %RH	74.0 %RH	-0.7 %RH	74.0 %RH	-- %RH	
Conditions Environnementales:			Température: 22 °C	Humidité: 45 %RH		
Type d'Étalonnage:						

Instrumentation St-Laurent Inc. Certifie que l'instrument ci-haut, rencontre ou excède les spécifications établies par le fabricant. Le système qualité de l'entreprise est conforme aux exigences de la norme ISO 17025 et les étalons utilisés pour effectuer l'étalonnage est retraçable au CNRC et/ou au NIST. Le degré d'incertitude est basé sur un niveau de confiance=95%, K=2.

DATE D'ÉTALONNAGE / ÉMISSION DU CERTIFICAT	
Date d'Étalonnage:	9 Mars 2019
Date du prochain Étalonnage:	9 Mars 2020
Date d'émission du certificat:	9 Mars 2019

CONFORMITÉ D'ÉTALONNAGE		
	Avant	Après
Conforme:	X	X
Non Conforme:		

Le Service d'évaluation des laboratoires d'étalonnage (CLAS) du Conseil national de recherches du Canada (CNRC) a évalué et certifié la capacité d'étalonnage du laboratoire et la traçabilité au Système international d'unités (SI) ou à des étalons acceptables selon le CLAS. Le présent certificat d'étalonnage est délivré conformément aux conditions de certification du CLAS et aux conditions d'accréditation du Conseil canadien des normes (CCN). Numéro d'accréditation du CCN: # 669. Le CLAS et le CCN ne garantissent pas l'exactitude des étalonnages individuels effectués par les laboratoires accrédités.



Martin Langlais - Technicien

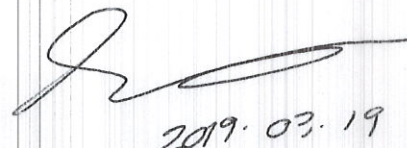

2019.03.19

# CERTIFICATE OF NIST TRACEABLE CALIBRATION

## Calibration Certificate No: 69804

### Customer Information

Customer: Services Polytests, Inc.  
Address : 695-B Gaudette  
St-Jean-sur-richelieu  
J3B 7S7

Customer PO #: 100476

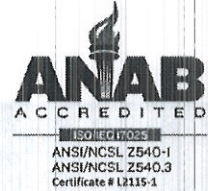

### Calibration Procedure Information

Procedure ID: GTP AIRVEL

Revision #: 6

Revision Date: 1/6/2013

### Calibration Standards Information

<u>Graffel ID</u>	<u>Manufacturer</u>	<u>Model #</u>	<u>Description</u>	<u>CAL Due</u>
10086	Furness Controls	FC0332	DP Transmitter	6/6/2019
10100	Graffel	n/a	Temperature	10/29/2019
10171	Furness	FC0332-2W	0 - .4" H2O	11/10/2018
10187	Vaisala	PTB210	Barometric Pressure Gauge	11/22/2018
10157	HOBO	UX100-011	RH/Temp logger	11/10/2018

### Sensor Information

Manufacturer: Omega

Description: Anemometer

Method Used: Pitot Tube

Model #: HHF143

Rated Accuracy:  $\pm$  See Attachment

Accuracy Specified By: Omega

Instrument ID#: EM153

Range: 40 to 7800 fpm

Condition: Functional

Serial #: 1015949

Comments: Calibration Date: 08/16/2018 | Note: Limited calibration range = 40 to 5000 fpm  
Calibration Due: 08/16/2019

*The instrument(s) listed on this certificate have been calibrated against standards traceable to the National Institute of Standards & Technology (NIST) or compared to nationally or internationally recognized consensus standards. The reported calibration uncertainty has a confidence level of 95% (k=2). A calibration uncertainty ratio of 4:1 was maintained unless required uncertainty is supported by analysis. Graffel, LLC. Quality Assurance System complies with applicable requirements of ISO/IEC-17025-2005, ANSI/NCSL Z540-1-1994 and ISO 9001: 2008. All results contained within this certificate relate only to item(s) calibrated. This certificate shall not be reproduced except in full and with the written consent of Graffel, LLC. Acceptance Criteria per Simple Acceptance Rule: Measurement Uncertainty is not applied to the measured value when in/out of tolerance statement is made.*

Performed By: Philip Davis

Date: 8/16/2018

Philip Davis  
Calibration Technician

**ATTACHMENT TO CALIBRATION CERTIFICATE 69804  
AS FOUND/AS LEFT DATA  
Page 2 of 2**

Reading From Standard,	Lower Limit of Meter Reading,	Measured Reading From Meter,	Upper Limit of Meter Reading,	Error,	Measurement Uncertainty,	STATUS
<b>Actual Air Velocity</b>						
fpm	fpm	fpm	fpm	fpm	fpm	
494	488	493	500	-1	2.47	Pass
1238	1225	1236	1251	-2	6.19	Pass
1805	1786	1804	1824	-1	9.03	Pass
2448	2423	2445	2473	-3	12.24	Pass
3063	3031	3064	3095	1	15.32	Pass
3724	3686	3727	3762	3	18.62	Pass
4388	4343	4392	4433	4	21.94	Pass
4911	4861	4914	4961	3	24.56	Pass

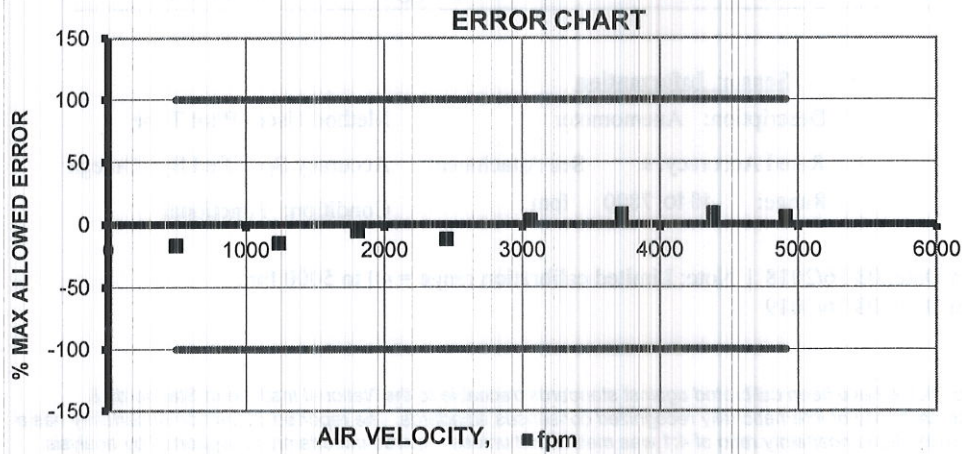

INSTRUMENT SPECIFICATIONS		
Test Fluid	Air	
Lower Range	40	fpm
Upper Range	7800	fpm
Rated Accuracy	1% Rding +1 digit	
LABORATORY AMBIENT CONDITIONS		
Pressure	14.36	psia
Humidity	56.22	% RH
Temperature	74.51	F



Flow - Humidity - Temperature - Pressure - Design - Consulting - Engineering  
**NIST Traceable Calibration Data Sheet**

Graftel, LLC. 870 Cambridge Drive, Elk Grove Village, IL 60007  
P. 847-364-2600 F. 847-364-2899

www.graftel.com

*[Signature]*  
2018.08.27



**Instrumentation  
Saint-Laurent** Inc.  
Accrédité ISO 17025



80 rue de la montagne  
St-Joseph du lac  
(Québec), J0N 1M0  
Tél: (450) 473-6169  
Fax: (450) 473-5207  
Email: inst.st-laurent@videotron.ca

## CERTIFICAT D'ÉTALONNAGE

No.Certificat: CE-EM-154 05/03/19

CLIENT	
Compagnie:	Services Polytests Inc
Adresse:	695 B rue Gaudette St-Jean-sur-Richelieu, Québec, J3B 7S7

SPÉCIFICATION DE CALIBRATION	
Procédure de service:	4IN9101
Précision requise:	+/- 2°C
Fréquence d'étalonnage: (jours)	365

SPÉCIFICATION DE L'INSTRUMENT			
Type d'instrument:	Enregistreur	Type d'entrée:	Temp
Manufacturier:	Keithley	Type de sortie:	Digitale
No. Model:	7700	Type de mesure:	Température
No. Série:	1306774	Gamme:	Divers
Emplacement:	N/A	No. Machine:	N.A.

SPÉCIFICATION DE L'ÉTALON			
Étalon Utilisé:	Fluke 744	No. du certificat d'étalonnage:	2019000879
No. Série:	7798010	Dernière date d'étalonnage:	7-Feb-19
Certificat fait par:	Alpha Controls	Prochaine date d'étalonnage:	7-Feb-20
Commentaire:			

RÉSULTAT D'ÉTALONNAGE:						
Entrée Source	Valeur Donnée	Valeur Actuelle	Erreur de Déviation	Valeur après Étalonnage	Incertitude Élargie	Commentaire
-17.000 mV	-17.000 mV	-17.011 mV	-0.011 mV	-17.011 mV	0.1 mV	Input#1
0.000 mV	0.000 mV	0.055 mV	+0.055 mV	0.055 mV	0.1 mV	Input#1
20.000 mV	20.000 mV	19.931 mV	-0.069 mV	19.931 mV	0.1 mV	Input#1
30.000 mV	30.000 mV	30.006 mV	+0.006 mV	30.006 mV	0.1 mV	Input#2
Input#3 Non-Conforme						
5.000 V.DC.	5.000 V.DC.	4.999 V.DC.	-0.001 V.DC.	4.999 V.DC.	0.1 V.DC.	Input#4
30.000 mV	30.000 mV	29.990 mV	-0.010 mV	29.990 mV	0.1 mV	Input#5
30.000 mV	30.000 mV	30.031 mV	+0.031 mV	30.031 mV	0.1 mV	Input#6
100.00 Ohms	100.00 Ohms	99.99 Ohms	-0.01 Ohms	99.99 Ohms	1.0 Ohms	Input#7
100.00 Ohms	100.00 Ohms	99.98 Ohms	-0.02 Ohms	99.98 Ohms	1.0 Ohms	Input#8
100.00 Ohms	100.00 Ohms	100.02 Ohms	+0.02 Ohms	100.02 Ohms	1.0 Ohms	Input#9
100.00 Ohms	100.00 Ohms	99.98 Ohms	-0.02 Ohms	99.98 Ohms	1.0 Ohms	Input#10
100.0 °C	100.0 °C	99.7 °C	-0.3 °C	99.7 °C	1.0 °C	Input#11 TypeT
100.0 °C	100.0 °C	99.7 °C	-0.3 °C	99.7 °C	1.0 °C	Input#12 TypeT
100.0 °C	100.0 °C	99.8 °C	-0.2 °C	99.8 °C	1.0 °C	Input#13 TypeJ
100.0 °C	100.0 °C	99.8 °C	-0.2 °C	99.8 °C	1.0 °C	Input#14 TypeJ
100.0 °C	100.0 °C	99.8 °C	-0.2 °C	99.8 °C	1.0 °C	Input#15 TypeJ
100.0 °C	100.0 °C	99.7 °C	-0.3 °C	99.7 °C	1.0 °C	Input#16 TypeJ
100.00 Ohms	100.00 Ohms	99.98 Ohms	-0.02 Ohms	99.98 Ohms	1.0 Ohms	Input#17
100.00 Ohms	100.00 Ohms	99.99 Ohms	-0.01 Ohms	99.99 Ohms	1.0 Ohms	Input#18
100.00 Ohms	100.00 Ohms	99.99 Ohms	-0.01 Ohms	99.99 Ohms	1.0 Ohms	Input#19
100.00 Ohms	100.00 Ohms	99.96 Ohms	-0.04 Ohms	99.96 Ohms	1.0 Ohms	Input#20
12.000 mA	12.000 mA	12.003 mA	+0.003 mA	12.003 mA	1.00 mA	Input#21
12.000 mA	12.000 mA	12.003 mA	+0.003 mA	12.003 mA	1.00 mA	Input#22
Conditions Environnementales: Température: 19 °C Humidité: 20 %RH						

5F09101



**Instrumentation  
Saint-Laurent** inc.  
Accrédité ISO 17025



80 rue de la montagne  
St-Joseph du lac  
(Québec), J0N 1M0  
Tél: (450) 473-6169  
Fax: (450) 473-5207  
Email: inst.st-laurent@videotron.ca

## CERTIFICAT D'ÉTALONNAGE

No.Certificat: CE-EM-154 05/03/19

CLIENT	
Compagnie:	Services Polytests Inc
Adresse:	695 B rue Gaudette
	St-Jean-sur-Richelieu, Québec, J3B 7S7

SPÉCIFICATION DE CALIBRATION	
Procédure de service:	4IN9101
Précision requise:	+/- 2°C
Fréquence d'étalonnage: (jours)	365

SPÉCIFICATION DE L'INSTRUMENT			
Type d'instrument:	Enregistreur	Type d'entrée:	Temp
Manufacturier:	Keithley	Type de sortie:	Digitale
No. Model:	7700	Type de mesure:	Température
No. Série:	1306774	Gamme:	Divers
Emplacement:	N/A	No. Machine:	N.A.
Type d'Étalonnage:		Test avec EM-147	

Instrumentation St-Laurent Inc. Certifie que l'instrument ci-haut, rencontre ou excède les spécifications établies par le fabricant. Le système qualité de l'entreprise est conforme aux exigences de la norme ISO 17025 et les étalons utilisés pour effectuer l'étalonnage est retraçable au CNRC et/ou au NIST. Le degré d'incertitude est basé sur un niveau de confiance=95%, K=2.

DATE D'ÉTALONNAGE / ÉMISSION DU CERTIFICAT	
Date d'Étalonnage:	5 Mars 2019
Date du prochain Étalonnage:	5 Mars 2020
Date d'émission du certificat:	5 Mars 2019

CONFORMITÉ D'ÉTALONNAGE		
	Avant	Après
Conforme:	X	X
Non Conforme:		

Le Service d'évaluation des laboratoires d'étalonnage (CLAS) du Conseil national de recherches du Canada (CNRC) a évalué et certifié la capacité d'étalonnage du laboratoire et la traçabilité au Système international d'unités (SI) ou à des étalons acceptables selon le CLAS. Le présent certificat d'étalonnage est délivré conformément aux conditions de certification du CLAS et aux conditions d'accréditation du Conseil canadien des normes (CCN). Numéro d'accréditation du CCN: # 669. Le CLAS et le CCN ne garantissent pas l'exactitude des étalonnages individuels effectués par les laboratoires accrédités.

*M L L J*

Martin Langlais - Technicien

*[Signature]*  
2019.03.19

## Certificat d'Étalonnage / Certificate of Calibration

**CLIENT :**  
 SERVICES POLYTESTS INC.  
 695-B GAUDETTE  
 ST-JEAN-SUR-RICHELIEU, QUEBEC

**Description:** CHRONOMÈTRE / STOPWATCH TIMER  
**Fabricant/ Manufacturer:** EXTECH  
**Modèle/ Model :** 365510  
**No série / Serial no :** 131636  
**# Inventaire / Asset # :** EM-175

**CERTIFICAT No / Certificate No:** 254068

**PROCÉDURE / Procedure :**  
 TRESCAL - EXTECH\_365510

**Date étalonnage/ Calibration Performed :** 2018-12-20

**Echéance/ Due Date :** 2019-12-20

Type de résultat / Results type : **As-Found = As-Left**

**Conditions de mesure / Measurement conditions**

Résultats d'essais / Test results : **Conforme / In Tolerance**

TEMPÉRATURE / Temp. : **22°C**  
 HUMIDITÉ / Humidity : **23% RH**

Usage restreint/ Restricted use :   
 Réparation effectuée / Repair performed :   
 Ajustement effectué / Adjustment performed :

**ÉTALONS UTILISÉS/ Standards Used:**

Identification	Manuf.	Model	Description	Ser. #	Étalonné/ Cal.	Echéance/ Due
PR0313	H-P	53132A	UNIVERSAL COUNTER	3546A03142	2018-07-03	2019-07-03
PR0392	AGILENT	33250A	FUNCTION/ARBITRARY WAVEFORM GENERATOR	MY40008014	2017-06-19	2019-06-19

Les spécifications mentionnées comme limites de tolérances d'essai sont celles établies par le manufacturier, sauf indication contraire.  
*Test tolerance limits are based on manufacturers specifications unless stated otherwise.*

**NOTES :**

  
 2019-01-07  
**Technicien :  
 Technician**

  
**Y. MEFTAH**

Le système qualité de la société est conforme aux exigences de la norme ISO 17025 et les étalons utilisés pour le processus d'étalonnage sont retraçables au SI par l'entremise du CNRC et/ou du NIST.

*Our quality system complies with the requirements of ISO 17025 and the standards used for the calibration are traceable to SI through NRC and/or NIST.*  
 LE DROIT D'AUTEUR DE CE CERTIFICAT APPARTIENT À TRESICAL / PRIMO INSTRUMENT INC. CE CERTIFICAT NE PEUT ÊTRE REPRODUIT AUTREMENT QU'EN ENTIER ET AVEC LE CONSENTEMENT PRÉALABLE ÉCRIT DU GROUPE TRESICAL.  
 TRESICAL / PRIMO INSTRUMENT INC. OWN COPYRIGHT OF THIS CERTIFICATE. THE CERTIFICATE MAY NOT BE REPRODUCED OTHER THAN IN FULL EXCEPT WITH THE PRIOR WRITTEN CONSENT OF THE TRESICAL GROUP.

CLIENT / Customer :

DESCRIPTION / Description :

MANUFACTURIER / Manufacturer :

MODÈLE / Model :

254068

SERVICES POLYTESTS INC.

CHRONOMÈTRE / STOPWATCH TIMER

EXTECH

365510

DESCRIPTION Description	LIMITES Limits	LECTURES Readings	LIMITES Limits
----------------------------	-------------------	----------------------	-------------------

**Temps écoulé, chronomètre sous test / Elapsed time on test stopwatch**

Minutes	Seconds	1/100 sec
27	0	60

Total au compteur / Reference timer: 162058.0 comptes/counts

( $\Delta t$ ) Deviation (1/100sec): 2.00

Deviation Par jour/ Per day (%): 0.0012 %

Deviation Par jour/ Per day (sec): 1.07 sec

\* Tolérances basées sur une déviation maximale de 3 sec/jour

\* Tolerances based on a 3 sec/day maximum deviation

Incertitude/ Uncertainty:  $\pm 37$  ms

Lorsque fournies dans le rapport, les incertitudes de mesure sont des incertitudes élargies représentant un niveau de confiance d'approximativement 95% , obtenu en multipliant l'incertitude-type composée par un facteur de couverture de k=2.

When supplied in the report, the measurement uncertainties are expanded uncertainties representing a confidence level of approximately 95% , obtain by multiplying the combined standard uncertainty by a coverage factor of k=2.

Min	Comptes / Counts Chronomètre/timer 162060	Max
* Secondes -3.00	Deviation 24hrs 1.07	* Secondes 3.00



**CERTIFICAT D'ÉTALONNAGE # 9799**

**Date d'étalonnage : 2018-11-14**

**Date d'émission du certificat : 2018-11-14**

**Services Polytests  
695 B Gaudette street  
St-Jean-sur-Richelieu, Québec, Canada  
J3B 7S7**

**Étalonnage d'un  
Shinigawa DCDA-2c S/N : 23544**

**CONFORMITÉ AU PROGRAMME DE QUALITÉ**

Tous les étalonnages sont effectués conformément au manuel d'assurance qualité de Polycontrols qui est conforme à la norme ISO/IEC 17025 – 2005, à la norme ISO 9001 – 2015 ainsi qu'à tout autre exigences de qualité définies dans la description d'achat des clients.

**TRAÇABILITÉ**

La traçabilité des étalons de débit au National Institute of Standards and Technology, NIST, est maintenue par les laboratoires de Fluke Corporation de Phoenix, Arizona et est conforme aux normes ISO/IEC 17025, AINSI/NCSL Z540-1-1994, ISO-10012-1, MIL-STD 45662A.

Le Service d'évaluation des laboratoires d'étalonnage (CLAS) du Conseil national de recherches du Canada (CNRC) a évalué et certifié la capacité d'étalonnage du laboratoire et la traçabilité au Système international d'unités (SI) ou à des étalons acceptables selon le CLAS. Le présent certificat d'étalonnage est délivré conformément aux conditions de certification du CLAS et aux conditions d'accréditation du Conseil canadien des normes (CCN). Le CLAS et le CCN ne garantissent pas l'exactitude des étalonnages individuels effectués par les laboratoires accrédités.

**APTITUDE EN MATIÈRE DE MESURE ET D'ÉTALONNAGE - CMC**

Les références utilisées pour l'étalonnage de débit ont une incertitude de  $\pm 0.2\%$  de la lecture pour les mesures entre 5 SCCM à 10 SLPM,  $\pm 0.3\%$  de la lecture pour les mesures entre 10 SLPM à 30 SLPM,  $\pm 0.2\%$  de la lecture pour les mesures entre 30 SLPM à 3000 SLPM,  $\pm 0.3\%$  de la lecture pour les mesures supérieures à 3000 SLPM jusqu'à 6000 SLPM et  $\pm 0.5\%$  pour les mesures inférieures à 5 SCCM jusqu'à concurrence de 1 SCCM, équivalent air ou azote. Les incertitudes exprimées sont élargies avec un facteur d'élargissement  $k = 2$ , et ce, pour un niveau de confiance d'environ 95 %, dans l'hypothèse d'une distribution normale incluant la résolution de l'instrument. Le rapport d'incertitude des essais (RIE) de cet étalonnage respecte un ratio de 4:1 à moins d'indication contraire.

**SOMMAIRE DES CONDITIONS DE L'INSTRUMENT EN TEST**

Conditions initiales	En bon état
Travail Effectué	Étalonnage de l'instrument
Résultats	Lectures initiales hors tolérance Lectures finales dans les tolérances
Remarques	Valeur de l'instrument corrigée = Lecture de l'indicateur de l'instrument * 0.98 K facteur Fréquence d'étalonnage aux 12 mois

  
Métrologiste

  
Responsable du laboratoire

2018. 11. 22

## Certificat d'étalonnage # 9799

Numéro de série:	23544	Station de mesure:	4
Date d'étalonnage:	2018-11-14	Procédure:	POS-CAL-005
Identification de l'instrument:	EM-178		

## Instrument de mesure de référence utilisé pour l'étalonnage initial

Description	Modèle	# Série	Traçabilité	Date dû
DHI molbloc (30 slpm)	3E4-VCR-V-Q	2359	1500231794	2019-01-19
DHI molbox1+	Molbox1+	2089	1500241952	2019-07-24
RTD Mist	Mist	L00295	2017007605	2018-12-07
Module 44.5 PSI avec Baro 163671	Module 30	160659	2018002180	2019-04-12

## Spécifications initiales de l'appareil

## Condition d'étalonnage

Spécifications initiales de l'appareil		Condition d'étalonnage	
Gaz	Air	Gaz	Air
Température d'opération		Température ambiante	21 °C
Pression à l'entrée		Pression ambiante	1009.77 mbar
Pression à la sortie		Orientation	Horizontale
Température de référence		Élastomère	Viton
Pression de référence		Valve	
Étendue d'échelle	10-2000 ALH		
Signaux Entrée/Sortie	-		
Alimentation			
Tolérance	±2 %O.R.		

## Lectures initiales

Débit du test ALH	Instrument en test L	Valeurs mesurées			Référence calculée L	Erreur calculée L	Tolérance acceptable L	TUR
		Pression PSIA	Température °C	Référence L				
364.6385	61.8500	14.6522	21.55	60.4150	60.6869	1.1631	1.2137	>4
612.3148	104.0800	14.6557	21.47	101.7210	102.1249	1.9551	2.0425	>4
1628.8459	276.5500	14.6757	21.45	269.8463	270.5303	6.0197	5.4106	>4

Carl Tessier Dansereau  
Métrologue

*Carl Tessier Dansereau*  
Signature

## Certificat d'étalonnage # 9799

Numéro de série:	23544	Station de mesure:	4
Date d'étalonnage:	2018-11-14	Procédure:	POS-CAL-005
Identification de l'instrument:	EM-178		

### Résultats initiaux

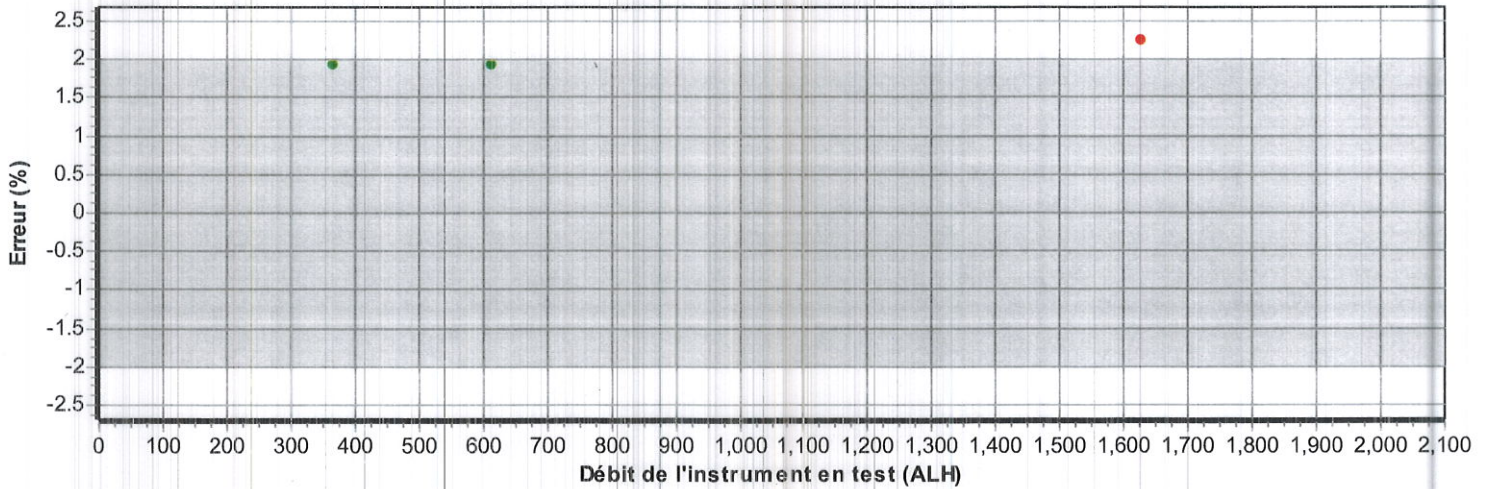

- La mesure (et son incertitude) se situe dans les tolérances
- La mesure (et son incertitude) se situe hors tolérance
- La mesure (et son incertitude) ne rencontre pas la marge de sécurité tel que spécifié dans le document G-8 de l'ILAC

Carl Tessier Dansereau  
Métrologue

Carl Tessier - Dansereau  
Signature

## Certificat d'étalonnage # 9799

Numéro de série:	23544	Station de mesure:	4
Date d'étalonnage:	2018-11-14	Procédure:	POS-CAL-005
Identification de l'instrument:	EM-178		

## Instrument de mesure de référence utilisé pour l'étalonnage final

Description	Modèle	# Série	Traçabilité	Date dû
DHI molbloc (30 slpm)	3E4-VCR-V-Q	2359	1500231794	2019-01-19
DHI molbox1+	Molbox1+	2089	1500241952	2019-07-24
RTD Mist	Mist	L00295	2017007605	2018-12-07
Module 44.5 PSI avec Baro 163671	Module 30	160659	2018002180	2019-04-12

## Spécifications finales de l'appareil

## Condition d'étalonnage

Spécifications finales de l'appareil		Condition d'étalonnage	
Gaz	Air	Gaz	Air
Température d'opération		Température ambiante	21.5 °C
Pression à l'entrée		Pression ambiante	1025.86 mbar
Pression à la sortie		Orientation	Horizontale
Température de référence		Élastomère	Viton
Pression de référence		Valve	
Étendue d'échelle	10-2000 ALH		
Signaux Entrée/Sortie	-		
Alimentation			
Tolérance	±2 %O.R.		

## Lectures finales

Débit du test ALH	Instrument en test L	Pression PSIA	Valeurs mesurées		Référence calculée L	Erreur calculée L	Tolérance acceptable L	TUR
			Température °C	Référence L				
352.3959	58.5060	14.8906	21.27	59.3386	58.5953	-0.0893	1.1719	>4
614.6929	102.2940	14.9046	21.20	103.7453	102.3248	-0.0308	2.0465	>4
1597.3393	265.5408	14.9230	21.23	270.0182	266.0123	-0.4715	5.3202	>4

*Fc. : 1.01007684*

Carl Tessier Dansereau  
Métrologue

*Carl Tessier Dansereau*  
Signature

## Certificat d'étalonnage # 9799

Numéro de série:	23544	Station de mesure:	4
Date d'étalonnage:	2018-11-14	Procédure:	POS-CAL-005
Identification de l'instrument:	EM-178		

## Résultats finaux

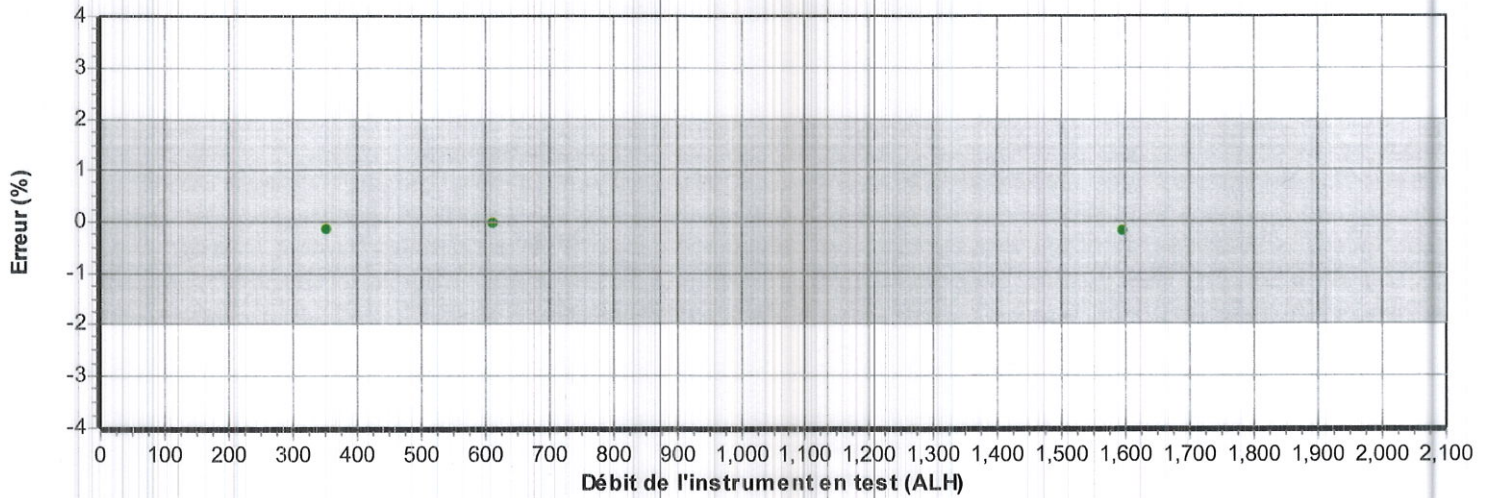

- La mesure (et son incertitude) se situe dans les tolérances
- La mesure (et son incertitude) se situe hors tolérance
- La mesure (et son incertitude) ne rencontre pas la marge de sécurité tel que spécifié dans le document G-8 de l'ILAC

Carl Tessier Dansereau  
Métrologue

*Carl Tessier Dansereau*  
Signature

**CERTIFICAT D'ÉTALONNAGE # 9801**

Date d'étalonnage : 2018-11-14  
Date d'émission du certificat : 2018-11-14

Services Polytests  
695 B Gaudette street  
St-Jean-sur-Richelieu, Québec, Canada  
J3B 7S7

Étalonnage d'un  
Shinigawa DCDA-2c S/N : 23543

**CONFORMITÉ AU PROGRAMME DE QUALITÉ**

Tous les étalonnages sont effectués conformément au manuel d'assurance qualité de Polycontrols qui est conforme à la norme ISO/IEC 17025 – 2005, à la norme ISO 9001 – 2015 ainsi qu'à tout autre exigences de qualité définies dans la description d'achat des clients.

**TRAÇABILITÉ**

La traçabilité des étalons de débit au National Institute of Standards and Technology, NIST, est maintenue par les laboratoires de Fluke Corporation de Phoenix, Arizona et est conforme aux normes ISO/IEC 17025, AINSI/NCSL Z540-1-1994, ISO-10012-1, MIL-STD 45662A.

Le Service d'évaluation des laboratoires d'étalonnage (CLAS) du Conseil national de recherches du Canada (CNRC) a évalué et certifié la capacité d'étalonnage du laboratoire et la traçabilité au Système international d'unités (SI) ou à des étalons acceptables selon le CLAS. Le présent certificat d'étalonnage est délivré conformément aux conditions de certification du CLAS et aux conditions d'accréditation du Conseil canadien des normes (CCN). Le CLAS et le CCN ne garantissent pas l'exactitude des étalonnages individuels effectués par les laboratoires accrédités.

**APTITUDE EN MATIÈRE DE MESURE ET D'ÉTALONNAGE - CMC**

Les références utilisées pour l'étalonnage de débit ont une incertitude de  $\pm 0.2\%$  de la lecture pour les mesures entre 5 SCCM à 10 SLPM,  $\pm 0.3\%$  de la lecture pour les mesures entre 10 SLPM à 30 SLPM,  $\pm 0.2\%$  de la lecture pour les mesures entre 30 SLPM à 3000 SLPM,  $\pm 0.3\%$  de la lecture pour les mesures supérieures à 3000 SLPM jusqu'à 6000 SLPM et  $\pm 0.5\%$  pour les mesures inférieures à 5 SCCM jusqu'à concurrence de 1 SCCM, équivalent air ou azote. Les incertitudes exprimées sont élargies avec un facteur d'élargissement  $k = 2$ , et ce, pour un niveau de confiance d'environ 95 %, dans l'hypothèse d'une distribution normale incluant la résolution de l'instrument. Le rapport d'incertitude des essais (RIE) de cet étalonnage respecte un ratio de 4:1 à moins d'indication contraire.

**SOMMAIRE DES CONDITIONS DE L'INSTRUMENT EN TEST**

Conditions initiales	En bon état
Travail Effectué	Lectures Initiales = Lectures finales, aucun ajustement Étalonnage de l'instrument
Résultats	Lectures initiales dans les tolérances
Remarques	Fréquence d'étalonnage aux 12 mois

  
Métrologiste

  
Responsable du laboratoire

## Certificat d'étalonnage # 9801

Numéro de série:	23543	Station de mesure:	4
Date d'étalonnage:	2018-11-14	Procédure:	POS-CAL-005
Identification de l'instrument:	EM-179		

### Instrument de mesure de référence utilisé pour l'étalonnage final

Description	Modèle	# Série	Traçabilité	Date dû
DHI molbloc (30 slpm)	3E4-VCR-V-Q	2359	1500231794	2019-01-19
DHI molbox1+	Molbox1+	2089	1500241952	2019-07-24
RTD Mist	Mist	L00295	2017007605	2018-12-07
Module 44.5 PSI avec Baro 163671	Module 30	160659	2018002180	2019-04-12

### Spécifications finales de l'appareil

### Condition d'étalonnage

Gaz	Air	Gaz	Air
Température d'opération		Température ambiante	21.5 °C
Pression à l'entrée		Pression ambiante	1027.25 mbar
Pression à la sortie		Orientation	Horizontale
Température de référence		Élastomère	Viton
Pression de référence		Valve	
Étendue d'échelle	10-2000 ALH		
Signaux Entrée/Sortie	-		
Alimentation			
Tolérance	±2 %O.R.		

### Lectures finales

Débit du test ALH	Instrument en test L	Valeurs mesurées		Référence L	Référence calculée L	Erreur calculée L	Tolérance acceptable L	TUR
		Pression PSIA	Température °C					
350.3144	59.1000	14.9078	21.31	59.1513	58.3496	0.7504	1.1670	>4
598.7895	101.1200	14.9160	21.26	101.1058	99.6653	1.4547	1.9933	>4
1605.3452	269.5100	14.9364	21.25	271.3957	267.1497	2.3603	5.3430	>4

*Fe: 0,98730288*

Carl Tessier Dansereau  
Métrologue

*Carl Tessier Dansereau*  
Signature

## Certificat d'étalonnage # 9801

Numéro de série: 23543	Station de mesure: 4
Date d'étalonnage: 2018-11-14	Procédure: POS-CAL-005
Identification de l'instrument: EM-179	

### Résultats finaux

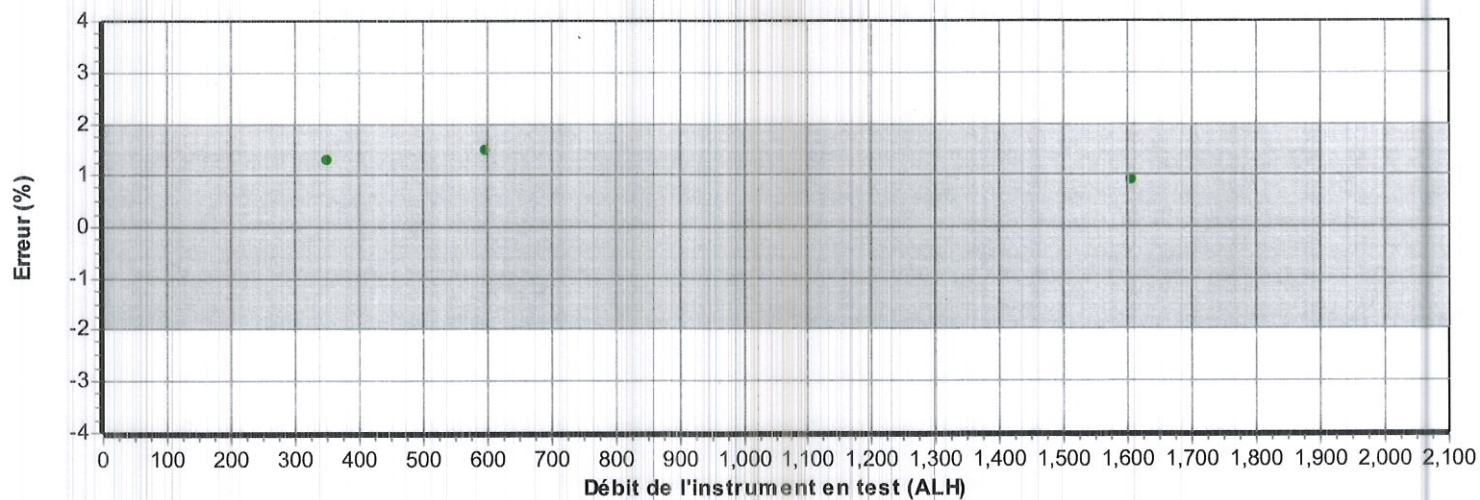

- La mesure (et son incertitude) se situe dans les tolérances
- La mesure (et son incertitude) se situe hors tolérance
- La mesure (et son incertitude) ne rencontre pas la marge de sécurité tel que spécifié dans le document G-8 de l'ILAC

Carl Tessier Dansereau  
Métrologue

*Carl Tessier Dansereau*  
Signature





## CERTIFICAT D'ÉTALONNAGE

No.Certificat: CE-EM-224 06/03/19

CLIENT	
Compagnie:	Services Polytests Inc
Adresse:	695 B rue Gaudette St-Jean-sur-Richelieu, Québec, J3B 7S7

SPÉCIFICATION DE CALIBRATION	
Procédure de service:	ISL-022
Précision requise:	+/- 1/32"
Fréquence d'étalonnage: (jours)	365

SPÉCIFICATION DE L'INSTRUMENT			
Type d'instrument:	Ruban à mesurer	Type d'entrée:	Mesure
Manufacturier:	Stanley	Type de sortie:	N/A
No. Model:	Leverlock 128#39;	Type de mesure:	Inch
No. Série:	N/A	Gamme:	0 à 12'
Emplacement:	Portable	No. Machine:	N/A

SPÉCIFICATION DE L'ÉTALON			
Étalon Utilisé:	Tape Mesure	No. du certificat d'étalonnage:	TA-47525320
No. Série:	17413592	Dernière date d'étalonnage:	23-Oct-17
Certificat fait par:	Starrett	Prochaine date d'étalonnage:	23-Oct-19
Commentaire:			

RÉSULTAT D'ÉTALONNAGE:					
Entrée Source	Valeur Donnée	Valeur Actuelle	Erreur de Déviation	Valeur après Étalonnage	Commentaire
1.00 "	1.00 "	1.00 "	0.00 "	1.00 "	
36.00 "	36.00 "	36.00 "	0.00 "	36.00 "	
72.00 "	72.00 "	72.00 "	0.00 "	72.00 "	
108.00 "	108.00 "	108.00 "	0.00 "	108.00 "	
132.00 "	132.00 "	132.00 "	0.00 "	132.00 "	
Conditions Environnementales: Température: 19 °C Humidité: 16 %RH					
Commentaire:					

Instrumentation St-Laurent Inc. Certifie que l'instrument ci-haut, rencontre ou excède les spécifications établies par le fabricant. Les étalons utilisés pour effectuer l'étalonnage est retraçable au CNRC et/ou au NIST.

DATE D'ÉTALONNAGE / ÉMISSION DU CERTIFICAT	
Date d'Étalonnage:	6 Mars 2019
Date du prochain Étalonnage:	6 Mars 2020
Date d'émission du certificat:	6 Mars 2019

CONFORMITÉ D'ÉTALONNAGE		
	Avant	Après
Conforme:	X	X
Non Conforme:		

  
Martin Langlais - Technicien

Martin Langlais - Technicien

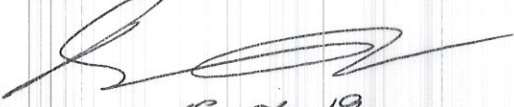
  
2019.03.19

Rapport d'étalonnage No. CA0124-510-092818

**Mettler Toledo**  
Service Business Unit Industrial  
1900 Polaris Parkway  
Columbus, Ohio 43240  
1-800-METTLER

# METTLER TOLEDO

ISO 9001 Registered  
ANSI/NCSL Z540-1 Accrédité



Accrédité par l'American Association for  
Laboratory Accreditation (A2LA)

CERT.CALIBRATION #1902.02

## Certificat d'étalonnage

### Client

**Société :** Services Polytests  
**Adresse :** 695-B Rue Gaudette  
**Ville :** Saint-Jean-Sur-Richelieu **État/Province :** Quebec  
**Code postal :** J3B 7S7 **Astea Customer ID:** 301288671

### Instrument

**Constructeur :** RICE LAKE **Modèle de terminal :** N/A  
**Modèle :** em257 **# série du terminal:** N/A  
**No de série :** C66221 **# série de l'imprimant** N/A  
**Capacité :** 1000 kg **Nbre de Divisions:** 20000  
**Résolution :** 0.05 kg **Procédure utilisée :** NIST Handbook 44  
**Classe :** III  
**No./ID d'inventaire:** EM256  
**Procédure:** Le présent certificat est émis conformément aux conditions de certification accordées par l'A2LA, en vertu de la norme ISO/IEC 17025. A2LA a évalué la capacité de mesure du laboratoire et la traçabilité des normes nationales reconnues.

**Date de calibrage :** 28-Sep-2018 **Date, prochaine Cal.** 30-Sep-2019  
**Signataire autorisé (A2LA) :** Pier-Hugues Riopel **Signature:** ELECTRONIC SIGNATURE

### Étalons de travail

**Retracabilité:** Les poids de test utilisés se réfèrent au National Institute of Standards and Technology.

Jeu de poids no :	Traçabilité NIST No.:	Classe ASTM/OIML	Date d'étalonnage :	Date proch. étalonnage
160941929	4350-8126171	Temperature Kit	18-Nov-2016	18-Nov-2018
42273	M17-0562	M1	23-Jan-2018	23-Jan-2019
T101-T150 (20kg)	1412537	M1	19-Apr-2018	19-Apr-2019

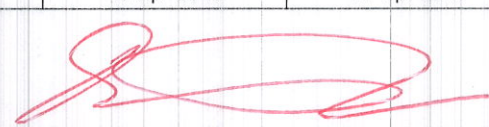
 2018-10-02

Version Logiciel : 4.6.4.2

Page 1 sur 4

© METTLER TOLEDO

Toute reproduction partielle du certificat est interdite, sous réserve du consentement écrit préalable du laboratoire émetteur.

**Résultats de mesure**

La température : 22 °C

Les conditions ambiantes ont été vérifiées afin d'assurer l'exactitude de l'étalonnage.

**Test de variation**

<input type="checkbox"/> 1	<input type="checkbox"/> 2
<input type="checkbox"/> 4	<input type="checkbox"/> 3

Poids Appliqués	Position	Avant Réglage	
		Valeur lue	
1: 200 kg	Position 1	200.00 kg	
2: 200 kg	Position 2	200.00 kg	
3: 200 kg	Position 3	199.95 kg	
4: 200 kg	Position 4	199.95 kg	
Erreur maximum :		0.05 kg	
Max Erreur Admissible :		0.15 kg	

**Linéarité**

	Avant réglage					Dans la Tolérance
	Poids Appliqués	Valeur lue	Erreur		Erreur admissible	
Zero 1	0.00 kg	0.00 kg	0.00 kg	0 d	1 d	YES
2	0.50 kg	0.50 kg	0.00 kg	0 d	1 d	YES
3	2.00 kg	2.00 kg	0.00 kg	0 d	1 d	YES
4	10.00 kg	9.95 kg	-0.05 kg	1 d	1 d	YES
Max 5	100.00 kg	100.00 kg	0.00 kg	0 d	2 d	YES

Méthode de substitution utilisée

Un réglage de la balance a été requis

Si non, les résultats "avant réglage" correspondent aux résultats tel que laissé.

OUI       NON

**Répétabilité**

Poids appliqués : 2.00 kg

	Chargé	Vide	Différence
1	2.00 kg	0.00 kg	2 kg
2	2.00 kg	0.00 kg	2 kg
3	2.00 kg	0.00 kg	2 kg
Erreur maximale :		0.00 kg	0.0 d
Tolérance :		0.05 kg	1 d

**Incertitude**

Mesure de l'incertitude = 0.029 kg

L'incertitude de mesure représente les incertitudes étendues selon un facteur de sécurité K=2 générant un niveau de confiance approximatif de 95 %. Des dispositions doivent être prises en matière d'environnement au lieu d'étalonnage, d'incertitude induite par l'article en étalonnage et d'effets indésirables causés par le transport du matériel d'étalonnage. Ces facteurs pourraient entraîner une incertitude plus grande que le CMC.

**Certificat de Pesée Minimale****Incertitude de mesure élargie**

$$U = U_0$$

$$U_{r1} = 0.03 \text{ kg}$$

**Exemple d'incertitudes élargies pour différentes valeurs de poids net :**

<i>Poids Net Affiché</i>	<i>Incertitude de mesure élargie</i>	
1 kg	0.03 kg	2.90000 %
10 kg	0.03 kg	0.29000 %
100 kg	0.03 kg	0.02900 %
500 kg	0.03 kg	0.00580 %
1000 kg	0.03 kg	0.00290 %

**Explication sur le tableau de pesée minimale**

Les valeurs du poids net affiché indiquées dans le tableau suivant sont les valeurs des pesées minimales. Pour ces valeurs, l'incertitude élargie de mesure, multipliée par un Facteur de Sécurité (1, 2, 3 ou 5) est inférieure ou égale à l'Erreur Relative R

**Tableau des Pesées Minimales pour différentes Erreurs Relatives et différents Facteurs de Sécurité**

<i>Erreur Relative Requise</i>	<i>Facteur de Sécurité FS</i>			
	<i>1x FS = 1</i>	<i>2x FS = 2</i>	<i>3x FS = 3</i>	<i>5x FS = 5</i>
0.1 %	29.00 kg	58.00 kg	87.00 kg	145.00 kg
0.2 %	14.50 kg	29.00 kg	43.50 kg	72.50 kg
0.5 %	5.80 kg	11.60 kg	17.40 kg	29.00 kg
1 %	2.90 kg	5.80 kg	8.70 kg	14.50 kg
2 %	1.45 kg	2.90 kg	4.35 kg	7.25 kg
5 %	0.58 kg	1.16 kg	1.74 kg	2.90 kg

**Remarques sur les valeurs de pesée minimale du tableau ci-dessus :**

- "N/A" est indiqué dans le tableau quand aucune valeur appropriée n'a pu être calculée.
- Pour les instrument à étendues et échelons multiples, les valeurs indiquées dans le tableau ci-dessus s'appliquent à la plus petite étendue de mesure.
- METTLER TOLEDO ne peut être tenu pour responsable du choix retenu concernant la sélection de l'Erreur Relative Requise ou du Facteur de Sécurité.
- Le client veille à ce que les paramètres de réglage restent identiques à ceux utilisés pour l'établissement de ce Constat de Vérification Standard.
- Le client veille à ce que l'environnement demeure identique aux conditions de travail retenues pour l'établissement de ce Constat de Vérification Standard.

**Remarques**

None.



22 Albiston Way  
Auburn, ME 04210  
800-292-6218  
207-777-6218  
Fax 207-777-6215  
www.specair.com

Date: 08/14/2017

## Certificate of Analysis

**Customer:**

VAC OXY

Results are reported in mole percent, unless otherwise indicated. Mixes are prepared via partial pressure methods, or gravimetrically, using high load high sensitivity electronic scales. Prior to use, scales are verified for accuracy using applicable NIST traceable weights; analyses are calibrated against reference materials traceable to NIST weights and/or NIST gas reference materials.

**Cylinder Serial #:** 809277

**Cylinder Size:** K

**CGA Connection:** 350

**Fill Pressure:** 1450 PSI

**Analysis:** Certified Standard

**Lot #:** 4722621

Component(s):	Requested Concentration(s):	Actual Concentration(s):
Carbon Monoxide	3%	3.0%
Carbon Dioxide	18%	18.0%
Oxygen	2%	2.0%
Nitrogen	BALANCE	BALANCE

**Expiration Date:** 08/2020

**Approved By:**

Tom Bosse

EM-275  
  
5-sept 2017

The information contained herein has been prepared at your request by qualified experts. While we believe that the information is accurate within the limits of the analytical methods employed, and is complete to the extent of the specific analyses performed, we make no warranty or representation as to the suitability of the use of the information for any particular purpose. The information is offered with the understanding that any use of the information is at the sole discretion and risk of the user. In no event shall the liability arising out of the use of the information contained herein exceed the fee established for providing such information.



22 Albiston Way  
Auburn, ME 04210  
800-292-6218  
207-777-6218  
Fax 207-777-6215  
www.specair.com

Date: 08/14/2017

## Certificate of Analysis

**Customer:**

VAC OXY

Results are reported in mole percent, unless otherwise indicated. Mixes are prepared via partial pressure methods, or gravimetrically, using high load high sensitivity electronic scales. Prior to use, scales are verified for accuracy using applicable NIST traceable weights; analyses are calibrated against reference materials traceable to NIST weights and/or NIST gas reference materials.

**Cylinder Serial #:** K3886

**Cylinder Size:** K

**CGA Connection:** 590

**Fill Pressure:** 1450 PSI

**Analysis:** Certified Standard

**Lot #:** 4722622

<b>Component(s):</b>	<b>Requested Concentration(s):</b>	<b>Actual Concentration(s):</b>
Carbon Monoxide	1%	1.0%
Carbon Dioxide	10%	10.0%
Oxygen	10%	10.0%
Nitrogen	BALANCE	BALANCE

**Expiration Date:** 08/2020

**Approved By:**

Tom Bosse

EM. 276  
5 sept 2017

The information contained herein has been prepared at your request by qualified experts. While we believe that the information is accurate within the limits of the analytical methods employed, and is complete to the extent of the specific analyses performed, we make no warranty or representation as to the suitability of the use of the information for any particular purpose. The information is offered with the understanding that any use of the information is at the sole discretion and risk of the user. In no event shall the liability arising out of the use of the information contained herein exceed the fee established for providing such information.

## APPENDIX 4: Unit pre burn



time minutes	Flue	Room	weight	right	back	bottom	top	left
1	89,81	77,27	8,60	118,47	94,06	127,131	100,9	108,7834
2	106,64	77,18	8,50	118,03	94,04	126,685	103,5	109,2107
3	218,51	77,33	8,40	117,58	93,87	126,253	141,8	109,3659
4	313,16	77,51	8,20	117,19	94,55	125,831	211,8	109,9949
5	402,14	77,25	7,90	116,82	95,28	125,364	328,4	107,8748
6	470,47	77,35	7,70	116,77	96,85	124,966	416,3	111,7593
7	497,01	77,47	7,50	117,13	99,23	124,519	488,2	104,7604
8	524,51	77,51	7,20	118,00	101,94	124,098	565,0	106,1550
9	512,07	77,56	7,00	119,46	105,20	123,690	603,6	109,4033
10	494,93	77,54	6,80	121,44	109,12	123,297	615,7	111,9180
11	479,35	77,76	6,70	124,04	112,77	122,963	621,3	108,6985
12	465,97	77,81	6,50	127,23	117,41	122,634	620,8	111,7740
13	473,62	77,99	6,40	130,89	121,73	122,402	624,6	115,4939
14	483,38	77,96	6,20	135,03	126,24	122,246	638,0	119,8106
15	491,36	78,17	6,10	139,54	130,88	122,181	657,4	123,1301
16	499,70	77,86	5,90	144,55	135,71	122,249	674,2	127,0380
17	516,90	77,94	5,70	149,94	139,41	122,413	700,8	130,9629
18	536,32	78,02	5,50	155,82	145,52	122,716	723,1	136,2316
19	546,83	78,11	5,30	161,57	141,66	123,176	743,9	139,2002
20	551,70	78,14	5,20	167,49	144,68	123,777	767,8	142,9930
21	547,63	78,21	5,00	173,83	151,72	124,513	783,6	147,6814
22	538,74	78,26	4,80	180,99	155,86	125,389	785,0	151,8624
23	536,39	78,31	4,70	188,02	156,50	126,458	790,7	156,6541
24	536,22	78,46	4,50	194,19	160,05	127,673	798,1	160,8944
25	537,64	78,83	4,40	200,72	162,89	129,019	804,9	164,4723
26	537,89	78,72	4,20	208,08	166,47	130,552	809,3	168,2471
27	542,25	78,53	4,10	215,78	169,95	132,242	818,7	171,8390
28	548,20	78,84	3,90	223,68	173,58	134,075	833,9	175,3676
29	540,84	78,68	3,80	231,76	177,08	136,087	837,7	178,8146
30	529,79	78,64	3,70	239,98	181,16	138,222	836,1	182,7359
31	524,97	78,79	3,50	248,31	182,99	140,481	831,0	185,0532
32	525,24	78,66	3,40	256,84	186,66	142,917	830,8	188,7192
33	524,63	78,45	3,30	265,47	191,24	145,456	830,8	193,3022
34	522,40	78,53	3,20	274,12	194,05	148,134	830,2	195,9053
35	517,79	78,65	3,10	282,86	195,76	150,897	825,0	197,8003
36	529,14	79,01	3,10	291,58	200,61	153,753	820,4	203,3598
37	482,12	79,16	21,59	301,47	183,88	157,003	790,4	185,3152
38	461,05	79,14	21,49	312,26	163,97	160,249	772,9	166,2814
39	471,79	79,07	21,29	322,01	156,90	163,468	771,5	159,4100
40	499,15	78,96	21,19	330,72	150,69	166,684	784,7	154,3534
41	539,23	79,43	20,99	338,26	148,90	170,014	808,3	153,9965
42	575,43	79,06	20,69	344,64	148,32	173,248	846,7	153,4443
43	591,92	79,42	20,49	349,86	146,72	176,504	877,6	151,7655
44	598,18	79,46	20,29	354,11	147,46	179,717	903,6	151,9045
45	598,08	79,34	20,09	357,65	148,56	182,914	922,5	152,8732
46	605,22	79,39	19,89	360,61	147,74	186,100	931,2	152,2243
47	600,40	79,67	19,59	363,19	149,17	189,169	931,2	153,0117
48	593,44	79,80	19,39	365,49	149,18	192,339	929,7	153,2056
49	591,53	79,84	19,29	367,62	150,90	195,357	934,5	154,8372
50	585,79	79,57	19,09	369,58	150,64	198,423	935,3	154,6081
51	585,71	79,33	18,89	371,42	153,70	201,383	942,4	157,6884
52	591,54	80,05	18,69	373,16	154,78	204,315	957,0	159,6026
53	594,08	79,93	18,49	374,73	154,68	207,248	969,2	159,5398
54	588,83	79,86	18,29	376,28	156,12	210,231	973,3	160,6196
55	584,63	79,82	18,09	377,80	157,46	213,112	971,5	161,6152
56	581,80	79,79	17,89	379,36	158,57	216,039	969,2	163,0975
57	585,36	79,96	17,69	381,04	158,73	218,987	969,8	162,8620
58	589,48	80,03	17,59	382,75	160,50	221,929	973,0	164,4154
59	589,49	79,86	17,39	384,47	161,55	224,626	973,3	165,7450
60	589,31	79,97	17,19	386,29	162,47	227,504	971,1	166,7181
61	588,21	79,71	16,99	388,14	163,31	230,290	969,1	166,8015
62	588,80	80,18	16,79	390,05	164,76	232,964	966,5	168,6171
63	586,99	79,75	16,59	391,97	163,23	235,758	963,5	167,4959
64	584,04	79,85	16,39	393,96	165,65	238,500	959,6	170,0271
65	579,71	79,64	16,29	395,88	166,34	241,145	954,4	170,5619
66	575,47	79,45	16,09	397,95	167,98	243,584	949,0	171,4288
67	573,44	79,99	15,89	400,02	167,53	246,200	944,7	171,2632
68	573,85	79,77	15,69	402,10	169,15	248,685	942,67	172,4186
69	575,60	79,88	15,50	404,13	171,08	251,190	941,59	174,1764
70	576,25	79,70	15,40	406,20	171,035	253,770	941,84	174,7327
71	576,82	80,14	15,20	408,31	173,203	256,229	942,97	176,6054
72	578,42	79,86	15,00	410,43	172,556	258,707	944,56	176,5210
73	579,41	79,49	14,80	412,61	174,029	261,198	946,58	177,8219
74	580,05	80,29	14,60	414,91	174,665	263,575	948,28	179,0687
75	580,43	80,09	14,40	417,29	177,421	266,005	949,83	181,3093
76	581,27	79,83	14,20	419,75	176,500	268,502	952,09	180,1961
77	580,91	80,21	14,10	422,30	176,389	271,085	952,74	180,9379
78	582,38	80,02	13,90	424,94	178,745	273,393	954,28	182,9730
79	583,13	80,54	13,70	427,68	179,012	275,863	955,57	183,3529
80	584,68	79,96	13,50	430,53	179,121	278,386	958,42	183,8623
81	585,96	80,48	13,30	433,45	177,806	280,847	961,34	181,8484
82	586,83	80,04	13,10	436,39	178,564	283,305	964,84	182,7764
83	587,52	80,59	13,00	439,42	182,053	285,786	968,97	185,8915
84	588,77	80,25	12,80	442,47	181,421	288,193	973,38	185,8566
85	589,30	79,71	12,60	445,54	185,025	290,469	977,14	188,6923
86	589,50	80,44	12,40	448,63	183,436	292,703	979,62	187,9273
87	590,61	80,59	12,20	451,63	185,957	294,899	982,92	190,7971
88	590,11	80,66	12,10	454,56	187,040	297,313	984,66	191,6170
89	591,40	80,88	11,90	457,48	185,772	299,531	987,22	190,4659
90	591,82	80,51	11,70	460,33	189,652	301,750	989,62	194,5052
91	593,66	80,12	11,50	463,20	190,517	303,997	993,33	194,6369
92	597,16	80,43	11,40	466,12	191,697	306,153	997,96	196,2119
93	599,00	80,24	11,20	469,07	192,824	308,255	1002,10	197,2460
94	601,66	80,61	11,00	471,96	190,300	310,570	1006,98	194,7881

95	604,73	80,72	10,80	474,85	191,916	312,878	1013,35	196,9425
96	607,70	80,99	10,70	477,73	195,817	315,036	1019,98	203,2819
97	608,94	80,60	10,50	480,60	194,213	317,427	1025,88	200,1712
98	611,52	80,69	10,30	483,49	196,897	319,619	1032,22	203,9306
99	614,27	80,71	10,10	486,40	197,737	321,852	1039,22	203,7379
100	618,12	80,51	9,90	489,44	199,322	324,013	1046,68	204,7249
101	622,00	80,28	9,80	492,45	199,560	326,138	1055,62	202,9774
102	626,34	80,86	9,60	495,51	200,098	328,330	1066,52	203,4605
103	628,06	79,99	9,40	498,63	200,956	330,418	1074,44	204,4845
104	627,62	81,00	9,30	501,89	202,467	332,259	1080,45	205,9390
105	627,43	80,70	9,10	505,13	204,108	334,350	1085,55	207,0399
106	626,20	81,13	8,90	508,42	203,693	336,533	1089,93	206,9824
107	624,66	80,92	8,80	511,73	204,700	338,830	1092,03	208,1365
108	622,54	80,58	8,60	515,02	206,626	340,974	1093,22	209,9323
109	619,62	80,80	8,50	518,31	206,546	343,110	1093,54	210,1205
110	614,89	80,46	8,30	521,54	206,764	345,596	1091,11	210,4652
111	607,37	80,77	8,20	524,75	207,710	347,919	1086,14	211,5542
112	603,14	80,52	8,10	527,96	208,070	350,251	1081,53	211,8350
113	598,53	80,76	7,90	531,11	208,736	352,619	1072,80	212,2600
114	592,99	80,95	7,80	534,27	206,651	355,184	1063,61	210,9601
115	586,71	80,66	7,70	537,42	208,432	357,504	1053,58	213,0662
116	579,88	80,59	7,60	540,57	207,163	359,672	1040,79	212,0453
117	575,03	80,90	7,40	543,82	207,556	361,983	1029,67	213,0296
118	568,98	80,68	7,30	547,07	211,111	364,275	1018,69	216,7067
119	562,07	81,00	7,20	550,41	210,846	366,476	1004,58	216,4445
120	554,82	81,16	7,10	553,78	208,702	369,162	989,93	214,9394
121	548,23	80,83	7,00	557,17	209,621	371,689	977,42	215,9989
122	543,55	81,04	6,90	560,56	208,903	374,164	966,84	215,3674
123	538,90	80,68	6,80	563,96	210,986	376,785	958,27	217,2140
124	535,37	80,92	6,70	567,31	209,303	379,327	946,77	215,5867
125	530,93	81,30	6,60	570,73	209,649	382,000	935,35	216,0386
126	527,48	81,03	6,60	574,17	211,296	384,384	925,67	217,8667
127	523,24	81,48	6,50	577,53	211,400	387,308	917,44	218,5984
128	521,35	80,90	6,40	580,86	211,375	390,085	911,67	218,6019
129	518,14	81,14	6,30	584,09	209,942	393,058	906,72	217,1675
130	514,68	80,81	6,20	587,27	207,808	395,934	901,83	215,3022
131	513,80	80,70	6,10	590,31	212,009	398,539	898,55	221,0137
132	511,71	81,03	6,00	593,33	209,523	401,144	895,68	218,0476
133	510,28	80,85	6,00	596,27	209,636	403,847	891,55	218,1308
134	506,89	81,25	5,90	599,11	212,255	406,699	885,36	223,2497
135	503,55	80,98	5,80	602,02	212,236	409,391	878,71	222,3201
136	499,16	80,89	5,70	604,82	212,780	412,063	870,03	223,0161
137	494,01	80,86	5,70	607,59	211,602	415,054	862,98	220,7933
138	490,72	81,25	5,60	610,27	213,675	418,031	855,56	224,5934
139	488,57	80,70	5,50	612,87	214,558	420,904	848,87	226,5168
140	485,22	81,29	5,40	615,42	210,814	424,302	842,87	221,7353
141	482,84	80,83	5,40	617,82	212,484	427,459	837,92	223,1529
142	480,96	81,06	5,30	620,09	211,988	430,716	833,11	222,6871
143	478,77	81,01	5,20	622,24	208,769	434,198	829,10	220,5486
144	476,72	81,03	5,20	624,24	211,499	437,148	824,35	222,5288
145	474,18	80,93	5,10	626,16	212,262	440,291	819,15	223,2127
146	472,93	80,77	5,10	627,99	210,211	443,607	814,54	221,0214
147	471,16	80,74	5,00	629,63	209,438	446,770	810,07	218,8495
148	469,07	80,94	5,00	631,14	211,148	449,865	805,48	220,2812
149	467,09	80,89	4,90	632,47	209,665	453,227	801,31	219,9595
150	465,48	80,74	4,80	633,74	211,510	456,377	796,74	221,2096
151	463,26	81,21	4,80	634,85	209,470	459,721	791,11	219,0420
152	461,22	81,21	4,70	635,84	209,704	463,211	785,32	219,5277
153	466,47	81,30	5,50	636,38	220,947	468,549	760,72	232,4957
154	475,87	81,47	4,60	636,70	222,231	471,514	756,92	230,6463
155	479,17	81,41	4,50	637,35	214,498	475,108	767,83	222,6105
156	480,72	81,44	4,50	637,82	217,141	478,336	775,35	226,5041
157	480,12	81,53	4,40	638,10	216,466	481,354	780,39	226,9475
158	478,39	81,77	4,40	638,38	214,379	484,526	783,76	222,5295
159	473,99	80,96	4,30	638,61	215,017	486,822	783,47	223,7149
160	469,36	81,27	4,30	638,77	213,647	488,998	781,01	222,4582
161	465,14	81,27	4,20	638,70	215,963	491,385	776,29	224,4645
162	462,60	81,05	4,20	638,54	214,539	493,517	771,46	224,4988
163	460,40	80,88	4,10	638,20	212,694	495,326	766,45	223,4908
164	456,35	80,93	4,10	637,72	214,579	497,140	760,99	225,3608
165	452,71	80,95	4,10	637,14	214,878	498,716	755,87	225,6447
166	446,65	80,73	4,00	636,41	214,204	500,187	748,61	225,2067
167	437,82	81,04	4,00	635,44	213,425	501,597	737,65	224,1345
168	430,17	81,15	4,00	634,39	214,309	503,120	725,52	225,2637
169	424,88	81,27	3,90	633,18	211,222	504,486	714,00	222,5504
170	420,50	81,31	3,90	631,75	211,595	505,145	703,81	222,4296
171	416,88	81,01	3,90	630,25	211,596	506,461	694,29	222,2296
172	413,72	80,93	3,80	628,59	207,902	507,758	685,85	217,9461
173	410,61	81,03	3,80	626,76	209,065	508,347	678,01	218,7728
174	408,08	80,87	3,80	624,80	208,867	509,443	670,83	218,5834
175	406,06	80,93	3,70	622,77	206,940	510,622	664,25	217,4981
176	405,18	81,17	3,70	620,55	206,837	511,594	658,57	217,1546
177	403,19	80,83	3,70	618,30	206,895	512,410	653,30	217,4061
178	402,10	81,06	3,70	616,03	208,003	513,405	648,70	218,4138
179	400,08	80,98	3,60	613,82	207,023	514,018	644,17	217,9091
180	399,06	81,15	3,60	611,49	207,145	514,365	639,87	217,8075
181	397,36	80,90	3,60	609,26	206,823	514,943	635,92	217,8694
182	396,07	81,20	3,50	606,99	202,204	515,556	631,97	213,7032
183	394,56	81,20	3,50	604,87	205,738	515,641	628,26	217,5650
184	393,69	81,03	3,50	602,67	203,901	516,090	624,66	216,0889
185	392,33	81,13	3,50	600,55	202,151	516,391	621,25	215,0113
186	391,27	81,15	3,40	598,40	202,688	516,663	617,58	217,2208
187	389,88	80,84	3,40	596,29	203,210	516,871	614,36	218,3385
188	389,12	80,95	3,40	594,17	204,173	517,181	611,22	220,2426
189	388,43	81,08	3,30	592,16	202,200	517,765	608,15	219,1999

190	387,54	81,15	3,30	590,19	203,048	517,801	605,61	221,0192
191	387,15	80,88	3,30	588,27	202,044	518,311	603,06	222,5493
192	361,79	81,51	0,00	586,19	212,033	521,792	584,23	227,7721
193	340,60	81,44	22,49	584,39	224,894	525,677	553,19	236,6127
194	347,08	81,53	22,39	582,72	234,555	529,295	528,56	247,8047
195	356,09	81,05	22,29	580,87	222,248	529,898	525,41	238,1015
196	391,32	81,33	22,09	578,76	213,731	531,207	557,42	229,7100
197	444,18	81,34	21,89	575,90	210,119	531,913	615,35	227,8351
198	506,90	81,19	21,69	572,30	206,771	532,586	677,38	221,4593
199	558,42	81,55	21,49	568,06	205,864	533,055	732,14	219,7589
200	578,70	81,59	21,19	563,36	204,163	533,382	783,24	217,1672
201	589,42	81,74	20,99	558,44	200,985	532,998	839,60	211,6038
202	606,15	81,35	20,69	553,47	203,598	533,260	880,76	211,6478
203	620,80	81,58	20,49	548,61	203,159	532,899	920,85	210,4780
204	625,60	81,76	20,29	543,94	202,056	532,275	947,52	209,1782
205	623,57	81,99	19,99	539,59	201,762	531,666	968,29	208,3260
206	622,06	81,88	20,05	535,54	201,614	530,594	982,24	208,0394
207	537,44	81,84	19,59	531,99	201,751	529,807	971,3	208,0939
208	486,86	81,72	19,39	529,41	203,092	528,684	953,9	209,7097
209	459,58	81,76	19,29	527,55	200,228	527,837	943,3	208,9018
210	441,79	82,03	19,09	526,02	201,217	526,756	935,7	209,7147
211	429,12	81,70	18,99	524,72	198,364	525,568	928,4	207,0775
212	418,79	81,67	18,79	523,63	200,177	523,562	921,8	208,8623
213	412,03	81,38	18,69	522,70	197,507	522,443	916,0	207,1387
214	406,65	81,57	18,59	521,82	196,730	521,258	911,5	207,1279
215	402,67	81,61	18,39	521,00	195,986	519,963	906,5	207,1155
216	398,35	81,93	18,29	520,28	195,905	518,404	900,6	207,5507
217	395,74	81,93	18,19	519,55	195,415	516,659	899,1	207,1776
218	394,39	81,92	17,99	518,86	194,103	515,470	897,6	206,9344
219	392,29	81,73	17,89	518,22	193,412	513,866	896,7	206,6972
220	392,15	81,74	17,69	517,64	192,797	512,463	897,8	205,6745
221	390,75	81,41	17,59	517,07	194,102	510,932	898,0	209,2966
222	389,72	81,67	17,39	516,48	192,657	509,536	901,0	207,3504
223	389,48	81,91	17,29	515,98	192,580	507,979	903,6	208,6957
224	388,77	81,55	17,19	515,57	191,320	506,487	903,6	205,9680
225	386,77	81,36	16,99	515,17	191,432	505,051	901,9	209,1786
226	385,81	81,66	16,89	514,89	190,268	503,591	900,4	207,3114
227	386,28	81,94	16,69	514,64	190,840	502,094	900,1	208,0462
228	386,25	81,75	16,59	514,44	186,878	500,831	901,1	203,2832
229	385,61	81,61	16,39	514,32	189,380	499,428	898,3	206,5071
230	384,58	81,89	16,29	514,25	186,154	498,125	896,7	202,7232
231	382,89	81,78	16,09	514,26	188,448	496,659	893,1	205,4991
232	381,20	82,03	15,99	514,38	186,554	495,201	888,8	201,7867
233	380,00	82,02	15,89	514,57	186,729	493,936	885,6	202,9598
234	379,72	82,12	15,69	514,81	183,580	492,832	883,5	200,4460
235	380,29	81,57	15,59	515,13	185,681	491,120	885,1	203,5798
236	379,88	82,09	15,39	515,52	183,155	490,135	884,9	199,8374
237	379,09	81,47	15,29	515,86	184,509	488,638	882,6	201,8751
238	378,69	82,11	15,10	516,27	184,191	487,340	883,1	197,9736
239	378,51	82,03	15,00	516,72	182,575	485,975	882,7	195,7870
240	377,47	81,52	14,90	517,18	183,255	484,716	882,5	198,0414
241	376,81	81,48	14,70	517,70	181,398	483,515	883,5	195,4875
242	376,38	81,97	14,60	518,25	182,489	481,964	883,5	197,7419
243	375,81	81,95	14,40	518,80	180,789	480,745	882,5	195,4440
244	374,39	82,15	14,30	519,38	180,691	479,633	880,3	195,1799
245	373,38	82,01	14,20	519,97	181,562	478,354	881,3	195,6201
246	372,22	81,80	14,00	520,50	181,076	477,141	879,4	195,1362
247	372,65	82,05	13,90	521,03	180,949	475,987	878,7	194,6696
248	371,68	82,06	13,80	521,58	180,812	474,941	876,9	194,8039
249	372,36	81,94	13,60	522,16	180,152	473,781	877,1	193,487
250	372,85	81,84	13,50	522,72	178,129	472,781	878,1	191,177
251	372,08	81,91	13,30	523,35	179,601	471,823	878,1	193,309
252	373,07	81,60	13,20	524,00	178,724	470,845	879,5	191,895
253	373,05	82,00	13,00	524,73	179,154	469,870	881,0	191,624
254	373,06	82,08	12,90	525,41	176,917	468,997	880,4	189,177
255	372,38	81,89	12,80	526,19	178,482	468,066	879,7	191,751
256	371,97	82,06	12,60	526,99	178,367	467,055	879,7	191,228
257	370,63	82,03	12,50	527,78	178,500	466,207	878,3	190,828
258	371,37	81,88	12,40	528,58	178,112	465,266	878,6	191,891
259	370,55	82,17	12,20	529,40	176,533	464,515	877,4	189,195
260	369,06	81,70	12,10	530,21	177,361	463,634	875,7	190,072
261	369,74	81,90	12,00	531,02	176,410	462,945	875,5	188,685
262	369,31	82,01	11,80	531,85	176,897	462,238	875,7	189,792
263	368,56	82,05	11,70	532,66	177,140	461,409	874,6	189,135
264	366,25	82,21	11,60	533,49	175,771	460,653	873,2	187,626
265	362,95	82,32	11,50	534,40	175,976	459,778	871,8	187,807
266	360,60	81,95	11,30	535,35	175,315	458,961	871,0	187,352
267	359,56	82,26	11,20	536,32	176,446	458,296	870,9	188,080
268	359,05	82,18	11,10	537,23	177,167	457,474	870,4	188,901
269	358,81	82,17	11,00	538,07	176,273	456,720	870,3	187,136
270	358,25	82,17	10,90	538,90	176,984	455,941	869,5	188,317
271	358,60	81,71	10,70	539,69	176,419	455,168	869,3	186,708
272	359,65	82,12	10,60	540,40	175,420	454,464	870,1	185,241
273	360,90	82,11	10,50	541,09	176,708	453,765	874,4	186,686
274	362,96	81,88	10,40	541,77	176,702	453,132	875,0	185,958
275	362,04	82,19	10,20	542,43	176,327	452,512	872,8	185,658
276	360,02	82,19	10,10	543,15	175,484	451,897	870,5	184,263
277	358,66	82,39	10,00	543,89	177,212	451,179	869,4	186,463
278	357,81	82,69	9,90	544,69	176,044	450,879	867,7	184,825
279	356,70	82,50	9,80	545,46	176,646	450,036	867,7	184,306
280	356,85	82,37	9,70	546,33	176,357	449,390	868,8	183,788
281	355,00	82,27	9,60	547,13	176,329	448,713	868,0	183,678
282	354,49	82,34	9,50	548,03	176,401	447,915	871,2	184,071
283	353,68	82,25	9,40	548,91	176,697	447,299	872,7	183,754
284	354,14	82,51	9,30	549,76	176,438	446,783	874,3	182,822

285	353,29	82,34	9,10	550,63	177,276	446,088	876,1	183,045
286	352,71	82,42	9,00	551,56	176,523	445,393	878,8	182,496
287	352,72	82,49	8,90	552,43	177,499	444,741	879,3	183,263
288	354,53	82,47	8,80	553,40	175,703	444,293	880,9	181,466
289	353,89	82,52	8,70	554,25	176,343	443,633	882,3	181,858
290	353,24	82,34	8,70	555,09	177,612	443,065	883,8	182,909
291	352,19	82,47	8,60	555,90	176,939	442,560	884,7	182,819
292	349,70	82,09	8,50	556,62	177,105	441,988	885,4	183,047
293	347,96	82,54	8,40	557,24	176,490	441,457	885,7	182,760
294	345,63	82,48	8,30	557,81	177,161	440,954	885,7	183,069
295	344,17	82,05	8,20	558,27	175,444	440,573	886,7	181,948
296	342,36	82,16	8,10	558,64	176,905	440,114	885,7	183,196
297	340,94	82,29	8,10	558,94	177,717	439,694	883,6	183,534
298	337,83	82,49	8,00	559,20	176,809	439,331	877,9	183,010
299	333,52	82,48	7,90	559,37	174,581	438,981	869,6	182,432
300	328,53	82,37	7,90	559,51	176,574	438,667	859,1	184,405
301	324,66	82,28	7,80	559,53	175,354	438,323	849,2	183,703
302	320,96	82,43	7,70	559,48	174,380	437,996	839,7	183,122
303	318,04	82,15	7,70	559,43	175,026	437,725	832,4	183,737
304	315,12	82,40	7,60	559,23	174,429	437,507	824,0	183,231
305	312,96	82,22	7,60	558,96	174,923	437,266	815,6	184,635
306	310,35	82,48	7,50	558,65	175,118	436,913	807,6	184,999
307	307,54	82,46	7,50	558,30	173,592	436,641	799,2	184,453
308	304,43	82,45	7,40	557,87	174,368	436,206	791,3	184,969
309	300,30	82,52	7,40	557,35	173,784	435,875	783,0	184,443
310	296,99	82,45	7,30	556,79	173,701	435,599	775,5	185,193
311	294,31	82,30	7,30	556,18	173,925	435,311	767,7	185,303
312	292,44	82,59	7,20	555,44	172,496	435,078	759,0	183,646
313	291,05	82,61	7,20	554,68	172,110	434,837	750,9	183,513
314	288,42	82,75	7,10	553,87	172,888	434,657	744,0	184,724
315	285,86	82,62	7,10	552,95	172,661	434,159	737,0	184,295
316	283,44	82,48	7,00	551,96	170,745	433,979	730,1	182,486
317	282,39	82,64	7,00	550,93	170,705	433,740	722,7	182,255
318	280,65	82,60	6,90	549,83	172,285	433,459	715,6	183,920
319	278,10	82,69	6,90	548,67	171,793	433,189	707,9	183,188
320	276,11	82,58	6,90	547,47	171,701	433,003	700,6	183,279
321	273,92	82,45	6,80	546,28	169,362	432,728	693,4	181,173
322	270,80	82,80	6,80	544,99	169,443	432,505	686,7	181,057
323	269,24	82,33	6,70	543,67	170,791	432,202	680,4	181,706
324	267,38	82,47	6,70	542,35	170,327	431,948	674,2	182,362
325	265,92	82,80	6,70	541,00	170,122	431,714	668,5	182,718
326	264,07	82,52	6,60	539,62	169,187	431,486	662,9	182,646
327	262,55	82,59	6,60	538,21	169,382	431,184	657,7	183,525
328	261,06	82,62	6,50	536,83	169,399	430,866	652,8	186,728
329	259,66	82,53	6,50	535,40	168,323	430,681	648,0	188,204
330	258,43	82,53	6,50	534,01	168,723	430,455	643,2	186,281
331	256,92	82,59	6,40	532,55	167,798	430,265	638,6	186,596
332	255,73	82,63	6,40	531,13	167,777	430,004	634,3	194,340
333	254,29	82,47	6,30	529,72	167,357	429,867	630,0	197,336
334	253,59	82,61	6,30	528,33	166,818	429,636	626,0	191,303
335	252,33	82,55	6,30	526,93	166,592	429,427	621,9	189,996
336	251,40	82,57	6,20	525,59	165,600	429,317	618,1	186,168
337	251,08	82,56	6,20	524,22	165,231	429,131	614,5	186,692
338	250,37	82,39	6,10	522,89	165,170	429,039	610,9	200,409
339	249,08	82,28	6,10	521,59	165,299	428,974	607,1	211,702
340	248,18	82,13	6,10	520,26	165,018	428,703	603,3	266,782
341	246,86	82,53	6,00	518,98	164,801	428,546	600,1	292,200
342	246,41	82,63	6,00	517,70	164,819	428,337	597,0	287,350
343	245,80	82,64	6,00	516,43	163,452	428,125	594,0	274,861
344	245,27	82,62	5,90	515,19	164,359	428,119	591,4	286,753
345	243,80	82,41	5,90	513,94	164,125	427,833	588,7	262,061
346	242,56	82,33	5,80	512,72	163,937	427,773	586,1	288,935
347	242,21	82,46	5,80	511,55	163,677	427,515	582,9	239,998
348	240,82	82,61	5,80	510,35	163,806	427,429	579,6	199,490
349	239,17	82,68	5,70	509,22	162,976	427,328	576,0	196,174
350	236,34	82,58	5,70	508,13	163,626	426,869	571,4	207,210
351	232,93	82,34	5,70	507,07	164,000	426,574	566,3	304,881
352	230,75	82,74	5,60	506,00	163,812	426,287	560,9	303,550
353	228,87	82,64	5,60	504,95	164,226	426,308	555,7	311,783
354	227,42	82,57	5,50	503,85	165,226	426,233	550,6	308,131
355	225,84	82,61	5,50	502,75	171,056	426,039	545,7	310,772
356	224,62	82,72	5,50	501,56	172,960	425,863	541,0	309,849
357	223,33	82,49	5,40	500,33	173,014	425,778	536,4	310,672
358	222,55	82,42	5,40	499,05	173,112	425,591	532,2	290,114
359	221,50	82,62	5,40	497,73	172,650	425,557	527,9	308,577
360	219,93	82,47	5,30	496,42	171,126	425,509	523,9	307,199
361	218,91	82,78	5,30	495,06	171,477	425,518	519,9	303,570
362	217,49	82,65	5,30	493,63	171,029	425,508	516,0	242,397
363	216,55	82,76	5,20	492,22	171,205	425,567	512,2	221,988
364	215,67	82,52	5,20	490,73	170,654	425,402	508,6	208,150
365	214,47	82,48	5,20	489,33	170,310	425,247	505,1	201,179
366	213,44	82,71	5,10	487,92	169,838	424,978	501,6	193,730
367	212,91	82,71	5,10	486,47	169,453	424,823	498,3	208,592
368	212,21	82,46	5,10	485,08	168,761	424,576	495,0	203,234
369	211,34	82,70	5,00	483,66	168,790	424,298	492,0	209,166
370	210,08	82,61	5,00	482,23	167,783	424,075	489,0	206,526
371	209,74	82,67	5,00	480,84	168,277	423,687	486,1	226,201
372	209,08	82,51	4,90	479,44	167,710	423,469	483,3	219,884
373	208,43	82,73	4,90	478,08	167,215	423,186	480,7	222,415
374	207,87	82,48	4,90	476,71	167,151	422,855	478,0	233,191
375	207,23	82,65	4,80	475,35	166,474	422,545	475,7	216,059
376	206,76	82,59	4,80	474,01	166,640	422,248	473,4	221,408
377	206,22	82,74	4,80	472,76	165,776	421,840	471,3	218,645
378	206,27	82,70	4,70	471,48	166,225	421,442	469,3	246,629
379	205,77	82,63	4,70	470,20	166,542	421,179	467,3	292,652

380	205,31	82,79	4,70	468,97	165,865	421,038	465,5	288,251
381	204,89	82,61	4,60	467,75	165,117	420,762	463,6	273,666
382	204,35	82,53	4,60	466,51	165,585	420,515	461,9	277,664
383	204,22	82,60	4,50	465,32	164,615	420,427	460,3	273,968
384	204,26	82,85	4,50	464,13	164,101	420,353	458,8	260,376
385	203,69	82,67	4,50	462,95	164,016	420,086	457,3	256,947
386	202,91	82,85	4,40	461,82	164,225	419,901	455,7	276,248
387	202,14	83,80	4,40	460,70	164,413	419,623	454,2	290,274
388	201,50	82,99	4,40	459,61	164,112	419,405	452,6	262,939
389	200,61	82,78	4,40	458,52	164,008	419,051	450,9	242,194
390	199,87	82,49	4,30	457,50	163,105	418,902	449,2	241,633
391	198,98	82,66	4,30	456,43	162,656	418,708	447,5	250,158
392	198,27	82,47	4,30	455,40	163,321	418,470	445,8	262,754
393	197,11	82,73	4,30	454,37	162,930	418,271	444,2	272,537
394	196,31	82,87	4,20	453,38	162,679	418,092	442,6	288,227
395	195,71	82,66	4,20	452,37	162,012	417,847	441,0	274,913
396	195,12	82,79	4,20	451,37	161,184	417,630	439,4	261,376
397	194,61	83,01	4,20	450,41	161,903	417,318	438,1	281,397
398	194,43	82,77	4,20	449,49	161,863	417,107	436,6	286,572
399	193,98	82,85	4,20	448,54	160,669	416,969	435,2	285,601
400	193,46	82,75	4,10	447,63	161,140	416,829	433,9	277,878
401	192,91	83,26	4,10	446,73	161,049	416,566	432,6	275,647
402	192,29	83,10	4,20	445,81	160,357	416,482	431,3	271,616
403	192,01	83,05	4,20	444,92	161,192	416,375	430,1	285,177
404	191,28	82,83	4,10	444,04	161,111	416,238	428,8	276,079
405	190,55	83,17	4,10	443,19	161,197	416,055	427,4	284,442
406	190,35	83,11	4,10	442,33	160,981	415,747	425,9	283,847
407	189,69	83,00	4,10	441,48	160,603	415,687	424,6	283,525
408	189,36	83,08	4,10	440,66	160,217	415,496	423,4	282,812
409	189,10	82,84	4,10	439,82	160,155	415,346	422,1	282,379
410	189,11	83,20	4,00	438,98	160,146	415,380	421,2	282,236
411	188,89	82,64	4,00	438,17	160,235	415,097	420,0	271,549
412	188,46	82,58	4,00	437,38	160,080	415,092	419,1	281,520
413	188,22	82,79	4,00	436,58	159,998	415,016	418,0	281,066
414	187,86	82,98	4,00	435,78	159,299	414,837	417,1	280,498
415	187,39	83,16	4,00	434,95	159,266	414,758	416,3	280,100
416	187,51	83,04	4,00	434,20	158,433	414,751	415,3	278,854
417	186,99	82,97	3,90	433,42	158,893	414,784	414,6	279,032
418	186,36	83,12	3,90	432,66	158,880	414,703	413,6	278,942
419	186,00	82,91	3,90	431,92	158,788	414,540	412,7	278,565
420	185,74	82,65	3,90	431,15	158,984	414,492	411,7	278,450
421	185,34	83,06	3,90	430,37	158,673	414,304	410,7	277,824
422	184,96	82,68	3,90	429,62	158,183	414,260	409,8	272,021
423	184,57	82,87	3,90	428,89	158,361	414,191	409,0	277,321
424	183,99	82,84	3,90	428,17	158,555	414,137	408,0	277,129
425	183,72	82,86	3,80	427,45	158,389	414,033	407,1	276,952
426	183,56	82,73	3,80	426,77	158,367	413,924	406,3	276,660
427	183,52	82,84	3,80	426,10	157,803	413,915	405,5	276,190
428	183,47	82,91	3,80	425,39	158,134	413,773	404,8	276,216
429	183,23	82,89	3,80	424,70	157,867	413,640	404,0	275,589
430	183,30	82,72	3,80	424,06	157,506	413,427	403,4	275,134
431	183,05	82,64	3,80	423,42	157,569	413,345	402,7	274,848
432	182,69	82,86	3,80	422,82	157,579	413,337	402,0	274,740
433	182,54	82,89	3,70	422,21	157,711	413,206	401,4	274,613
434	182,56	82,97	3,70	421,61	157,461	413,136	400,8	274,329
435	182,32	82,68	3,70	420,96	156,974	413,146	400,3	273,625
436	181,80	82,81	3,70	420,36	156,976	413,053	399,8	273,617
437	181,87	82,79	3,70	419,75	156,947	413,041	399,3	273,520
438	181,38	82,80	3,70	419,16	157,195	413,026	398,9	273,636
439	181,12	83,10	3,70	418,59	156,777	412,853	398,4	273,131
440	181,18	83,01	3,70	418,02	156,813	412,788	398,0	272,860
441	180,83	82,86	3,60	417,48	157,070	412,769	397,5	272,969
442	181,14	83,01	3,60	417,00	157,413	412,690	397,1	273,026
443	181,05	82,95	3,60	416,48	155,923	412,610	396,9	271,389
444	180,67	82,90	3,60	416,00	156,648	412,569	396,6	272,117
445	180,49	82,99	3,60	415,49	157,033	412,745	396,3	272,353
446	180,32	82,99	3,60	415,01	157,152	412,703	395,9	272,357
447	180,34	83,12	3,50	414,51	155,633	412,725	395,6	268,618
448	180,20	83,05	3,50	414,05	156,873	412,633	395,4	271,537
449	179,83	83,09	3,50	413,57	156,869	412,539	395,1	271,592
450	179,53	82,86	3,50	413,15	156,783	412,560	394,7	271,399
451	179,63	82,88	3,50	412,71	156,133	412,620	394,5	270,585
452	179,76	82,84	3,50	412,23	156,688	412,675	394,1	271,051
453	179,52	83,00	3,50	411,82	156,063	412,503	393,9	270,360
454	179,30	82,92	3,50	411,36	156,386	412,361	393,6	270,507
455	179,03	83,13	3,40	410,91	156,175	412,449	393,3	270,139
456	178,91	83,07	3,40	410,47	156,271	412,359	392,9	270,080
457	178,97	83,00	3,40	410,06	156,142	412,295	392,7	269,757
458	179,08	83,25	3,40	409,66	156,529	412,269	392,5	269,996
459	178,90	83,10	3,40	409,22	156,233	412,224	392,3	269,572
460	178,83	83,23	3,40	408,76	155,701	412,208	392,0	268,852
461	178,83	83,28	3,40	408,31	156,337	412,224	391,7	269,478
462	178,64	83,32	3,40	407,89	155,059	412,038	391,5	266,475
463	178,56	83,04	3,30	407,49	155,932	412,057	391,4	268,989
464	178,36	83,08	3,30	407,07	156,130	412,232	391,1	268,783
465	178,47	83,06	3,30	406,64	155,888	412,055	391,0	268,717
466	178,43	83,01	3,30	406,25	155,997	412,014	390,6	268,695
467	178,37	83,11	3,30	405,82	155,306	412,100	390,4	267,949
468	178,38	82,93	3,30	405,44	155,568	412,002	390,3	268,155
469	178,32	83,23	3,30	405,05	155,753	411,703	390,2	268,297
470	178,16	83,14	3,30	404,70	155,943	411,397	390,0	267,399
471	178,20	83,22	3,30	404,34	156,142	411,328	389,7	267,300
472	178,15	83,22	3,20	404,03	156,001	411,370	389,4	268,190
473	178,08	83,23	3,20	403,72	156,111	411,231	389,2	268,129
474	178,18	82,94	3,20	403,34	155,897	411,253	389,0	267,980

475	178,13	83,18	3,20	402,98	155,679	411,182	388,7	267,591
476	178,01	83,10	3,20	402,63	154,950	411,342	388,4	266,615
477	177,84	83,11	3,20	402,28	155,352	411,270	388,0	267,358
478	177,61	83,43	3,20	401,91	155,988	411,111	387,6	267,576
479	177,45	83,02	3,20	401,58	154,941	411,112	387,1	266,629
480	177,45	83,09	3,10	401,26	155,293	411,147	386,7	266,895
481	177,17	83,24	3,10	400,94	155,344	411,035	386,4	266,957
482	177,02	82,97	3,10	400,60	155,351	411,005	386,0	266,676
483	176,75	83,12	3,10	400,28	155,444	411,110	385,7	266,653
484	176,49	83,22	3,10	400,00	154,673	411,279	385,3	265,667
485	176,22	83,15	3,10	399,71	155,461	411,429	385,0	266,328
486	176,10	83,04	3,10	399,49	155,076	411,393	384,6	266,063
487	175,94	83,18	3,00	399,24	154,682	411,415	384,4	265,296
488	175,84	83,49	3,00	399,01	154,078	411,512	384,2	264,453
489	175,92	83,37	3,00	398,78	154,973	411,505	383,9	265,166
490	175,94	83,19	3,00	398,55	155,033	411,568	383,7	265,139
491	175,93	83,30	3,00	398,32	155,273	411,632	383,4	265,344
492	175,83	83,73	3,00	398,10	155,288	411,601	383,2	265,067
493	175,89	83,32	3,00	397,90	154,823	411,642	383,0	264,355
494	175,58	83,50	3,00	397,70	154,452	411,690	382,7	263,801
495	175,52	83,27	3,00	397,46	154,932	411,757	382,4	264,253
496	175,20	83,52	2,90	397,24	154,572	411,758	382,1	263,825
497	175,15	83,36	2,90	397,01	154,413	412,155	381,7	263,406
498	175,31	83,33	2,90	396,79	154,647	411,879	381,4	263,704
499	175,03	83,46	2,90	396,55	154,940	411,949	381,1	263,548
500	174,85	83,31	2,90	396,30	155,011	411,906	380,7	263,629
501	174,85	83,28	2,90	396,04	154,564	411,656	380,3	262,830
502	174,87	83,28	2,90	395,79	155,041	411,650	380,0	263,334
503	174,83	83,17	2,80	395,51	155,040	411,620	379,8	263,265
504	174,73	83,17	2,80	395,22	154,664	411,692	379,5	262,750
505	174,91	83,23	2,80	394,92	154,418	411,732	379,2	262,423
506	175,11	83,10	2,80	394,60	154,332	411,656	379,0	262,393
507	175,01	83,05	2,80	394,27	154,371	411,707	378,8	262,258
508	174,95	83,23	2,80	393,99	154,139	411,676	378,5	261,927
509	174,65	83,02	2,80	393,66	153,856	411,643	378,2	261,331
510	174,64	83,11	2,80	393,35	154,400	411,575	377,8	261,851
511	174,60	83,48	2,80	393,05	154,537	411,535	377,8	261,723
512	174,18	83,17	2,70	392,75	154,569	411,561	377,4	261,812
513	174,19	83,19	2,70	392,46	153,841	411,559	377,1	260,960
514	174,02	83,13	2,70	392,17	154,918	411,467	377,0	261,731
515	174,09	83,03	2,70	391,90	154,768	411,432	376,7	261,705
516	174,04	83,02	2,70	391,65	154,764	411,450	376,5	261,483
517	173,96	82,94	2,70	391,38	153,915	411,462	376,3	260,629
518	174,00	83,04	2,70	391,12	154,594	411,492	376,1	261,228
519	174,13	82,86	2,70	390,86	154,679	411,493	375,9	261,057
520	173,82	83,03	2,70	390,64	154,216	411,440	375,7	260,565
521	173,55	83,05	2,60	390,38	154,429	411,435	375,5	260,750
522	173,45	83,10	2,60	390,14	154,099	411,384	375,2	260,373
523	173,43	83,04	2,60	389,93	154,300	411,369	375,0	260,645
524	173,45	82,93	2,60	389,68	154,643	411,137	374,7	260,643
525	173,35	83,22	2,60	389,46	154,454	411,191	374,5	260,391
526	173,51	83,14	2,60	389,18	154,339	411,036	374,3	260,118
527	173,35	82,88	2,60	388,94	154,061	410,865	374,2	259,814
528	173,52	83,06	2,60	388,70	154,660	410,782	373,8	260,152
529	173,39	82,94	2,50	388,43	154,235	410,658	373,7	259,825
530	173,11	83,03	2,50	388,20	153,517	410,525	373,6	258,971
531	172,90	83,13	2,50	387,93	153,823	410,420	373,3	259,146
532	172,75	83,17	2,50	387,71	154,402	410,374	373,2	259,475
533	172,68	83,11	2,50	387,46	153,698	410,160	373,0	258,717
534	172,71	83,12	2,50	387,22	154,508	410,037	372,7	259,398
535	172,66	83,13	2,50	386,97	153,784	410,003	372,4	258,610
536	172,63	82,88	2,50	386,74	154,361	409,918	372,2	259,008
537	172,76	83,06	2,40	386,51	153,853	409,858	371,9	258,737
538	172,64	83,02	2,40	386,25	154,123	409,711	371,7	258,561
539	172,59	83,08	2,40	386,04	154,279	409,589	371,4	258,771
540	172,65	83,27	2,40	385,80	154,376	409,479	371,3	258,624
541	172,45	83,12	2,40	385,55	153,893	409,470	371,1	258,007
542	172,45	83,03	2,40	385,34	154,371	409,402	370,8	258,446
543	172,34	82,95	2,40	385,09	153,923	409,318	370,7	258,135
544	172,45	83,01	2,40	384,87	152,919	409,234	370,6	256,679
545	172,48	82,80	2,40	384,62	154,003	409,168	370,5	257,539
546	172,30	82,86	2,30	384,45	153,799	409,172	370,3	257,474
547	172,29	83,02	2,30	384,22	153,375	408,996	370,1	256,819
548	172,15	82,91	2,30	384,02	153,743	408,977	370,0	256,999
549	172,04	82,79	2,30	383,80	153,470	408,875	369,8	256,622
550	172,25	82,75	2,30	383,60	154,153	408,915	369,5	257,335
551	171,83	82,85	2,30	383,37	153,549	408,817	369,5	256,524
552	171,82	82,94	2,30	383,17	153,866	408,863	369,3	256,629
553	171,85	82,72	2,30	383,01	153,723	408,731	369,0	256,403
554	172,09	82,78	2,20	382,85	154,265	408,645	368,9	256,784
555	172,37	82,98	2,20	382,69	153,726	408,491	368,7	256,352
556	172,00	82,83	2,20	382,54	153,317	408,463	368,6	255,719
557	171,97	82,90	2,20	382,39	154,061	408,494	368,4	256,275
558	171,75	82,95	2,20	382,23	154,162	408,565	368,2	256,277
559	171,81	83,10	2,20	382,09	153,925	408,527	368,1	255,989
560	171,58	82,97	2,20	381,92	153,891	408,438	367,8	256,107
561	171,62	83,01	2,20	381,74	153,732	408,408	367,6	255,726
562	171,75	82,79	2,10	381,57	153,348	408,363	367,3	255,264
563	171,52	82,82	2,10	381,43	153,164	408,288	367,0	254,781
564	171,41	82,90	2,10	381,30	152,766	408,232	366,7	254,293
565	171,36	83,12	2,10	381,12	153,654	408,392	366,3	255,036
566	171,38	82,80	2,10	380,97	153,615	408,197	366,3	255,052
567	171,18	82,80	2,10	380,84	152,507	408,279	366,1	253,836
568	171,41	83,03	2,10	380,72	152,406	408,314	366,0	253,594
569	171,36	82,85	2,10	380,56	152,514	408,320	365,9	253,428

570	171,25	83,00	2,10	380,43	152,906	408,393	365,7	253,517
571	171,41	82,82	2,00	380,29	152,992	408,483	365,6	253,580
572	171,49	82,90	2,00	380,15	153,199	408,681	365,6	253,740
573	171,20	82,63	2,00	380,02	153,579	408,699	365,4	253,939
574	171,26	82,84	2,00	379,87	153,200	408,696	365,2	253,457
575	171,27	82,85	2,00	379,76	153,220	408,804	365,2	253,299
576	171,28	82,84	2,00	379,65	153,273	408,829	365,0	253,444
577	171,46	82,70	2,00	379,52	153,440	409,020	364,9	253,409
578	171,64	82,77	2,00	379,42	153,511	408,970	365,1	253,457
579	171,45	82,77	1,90	379,32	153,425	409,098	365,1	253,085
580	171,40	82,96	1,90	379,17	153,097	409,203	365,0	252,528
581	171,49	82,61	1,90	379,05	153,306	409,275	365,0	252,669
582	171,35	82,78	1,90	378,95	152,697	409,315	365,0	251,928
583	171,42	82,74	1,90	378,88	153,119	409,425	365,0	252,233
584	171,23	82,67	1,90	378,76	153,038	409,474	365,1	252,015
585	171,27	82,79	1,90	378,69	153,513	409,531	364,9	252,280
586	171,28	82,74	1,90	378,61	153,520	409,557	364,9	252,076
587	171,28	82,66	1,90	378,51	153,463	409,607	364,8	251,554
588	171,34	82,71	1,80	378,46	153,355	409,696	364,7	251,963
589	171,42	82,58	1,80	378,38	153,174	409,669	364,6	251,548
590	171,29	82,71	1,80	378,32	152,911	409,671	364,7	251,094
591	171,25	82,69	1,80	378,26	153,419	409,635	364,6	251,405
592	171,09	82,57	1,80	378,19	152,463	409,628	364,4	249,957
593	171,07	82,68	1,80	378,14	152,921	409,583	364,5	250,852
594	171,06	82,76	1,80	378,07	153,036	409,409	364,3	250,535
595	170,86	82,76	1,80	378,01	153,305	409,376	364,3	251,037
596	170,99	82,75	1,70	378,00	153,043	409,249	364,3	250,867
597	170,93	82,90	1,70	378,00	153,131	408,974	364,2	250,580
598	170,81	82,86	1,70	377,98	153,675	408,978	364,1	251,124
599	170,86	82,66	1,70	377,99	152,856	408,860	364,0	250,380
600	170,65	82,58	1,70	377,98	153,464	408,789	364,0	250,887
601	170,81	82,86	1,70	377,95	153,337	408,646	364,0	250,767
602	170,96	82,70	1,70	377,94	152,803	408,452	364,0	250,019
603	171,03	82,84	1,70	377,94	153,446	408,369	364,0	250,529
604	170,90	82,81	1,70	377,93	153,733	408,207	363,9	250,637
605	170,99	82,74	1,60	377,95	152,759	408,108	363,8	249,596
606	170,98	82,68	1,60	377,96	153,227	407,932	363,8	250,210
607	171,34	82,75	1,60	377,97	152,603	407,753	363,9	249,368
608	171,30	82,85	1,60	377,95	153,058	407,754	364,0	249,735
609	171,19	82,74	1,60	377,93	152,663	407,585	364,1	249,133
610	171,25	82,83	1,60	377,95	153,233	407,440	364,1	249,822
611	171,32	82,87	1,60	377,96	153,171	407,410	364,3	249,457
612	171,54	82,73	1,60	377,99	153,680	407,070	364,4	249,935
613	171,44	82,66	1,60	378,04	153,776	406,935	364,5	249,824
614	171,30	82,95	1,50	378,09	153,272	406,877	364,5	249,322
615	171,58	82,98	1,50	378,07	153,476	406,661	364,6	249,567
616	171,51	82,68	1,50	378,09	153,140	406,535	364,5	249,044
617	171,43	82,44	1,50	378,09	153,211	406,329	364,5	249,318
618	171,55	82,58	1,50	378,10	152,898	406,322	364,7	248,593
619	171,71	82,60	1,50	378,10	153,728	406,308	364,8	249,270
620	171,77	82,67	1,50	378,07	153,334	406,300	365,1	248,703
621	171,75	82,50	1,40	378,07	152,931	406,336	365,4	248,228
622	171,67	82,57	1,40	378,07	153,656	406,359	365,6	248,841
623	171,48	82,57	1,40	378,06	153,918	406,296	365,8	248,852
624	171,77	82,56	1,40	378,06	153,845	406,508	366,1	248,930
625	171,85	82,88	1,40	378,08	153,740	406,423	366,3	248,935
626	171,94	82,70	1,40	378,07	153,883	406,390	366,4	248,668
627	172,24	82,67	1,40	378,09	154,108	406,390	366,7	248,876
628	172,12	82,50	1,40	378,12	154,222	406,453	366,8	248,893
629	172,25	82,65	1,40	378,13	154,193	406,605	367,1	248,859
630	172,60	82,60	1,30	378,16	154,119	406,711	367,5	248,775
631	172,68	82,63	1,30	378,17	154,194	406,696	367,9	248,250
632	173,02	82,54	1,30	378,18	154,103	406,801	368,2	248,231
633	172,99	82,64	1,30	378,21	153,874	406,842	368,7	247,886
634	173,13	82,73	1,30	378,24	154,242	406,969	369,0	247,984
635	173,47	82,97	1,30	378,26	153,626	407,010	369,4	246,926
636	173,28	82,90	1,30	378,27	154,388	407,210	369,8	247,531
637	173,48	82,48	1,30	378,34	154,467	407,265	370,1	247,440
638	173,63	82,62	1,20	378,36	153,602	407,361	370,4	244,275
639	173,74	82,71	1,20	378,36	154,126	407,442	370,6	246,022
640	173,61	82,45	1,20	378,38	153,960	407,483	370,8	246,504
641	173,84	82,91	1,20	378,33	154,157	407,491	371,0	246,377
642	173,92	83,07	1,20	378,37	154,583	407,546	371,2	246,789
643	174,02	83,21	1,20	378,38	154,286	407,675	371,5	246,519
644	174,26	82,88	1,20	378,43	154,430	407,663	371,7	246,445
645	174,28	82,72	1,20	378,48	154,388	407,880	371,9	246,165
646	174,30	82,66	1,20	378,49	153,797	407,952	372,1	245,199
647	174,28	82,60	1,10	378,49	154,757	407,976	372,4	245,158
648	174,22	82,63	1,10	378,53	154,001	408,120	372,8	244,090
649	174,38	82,65	1,10	378,52	154,732	408,210	373,1	244,170
650	174,33	82,55	1,10	378,57	154,463	408,280	373,2	243,882
651	174,44	82,53	1,10	378,61	154,520	408,542	373,5	244,038
652	174,81	82,77	1,10	378,62	154,630	408,640	373,8	243,956
653	174,76	82,99	1,10	378,62	154,836	408,853	374,0	244,210
654	174,50	82,92	1,10	378,67	154,419	409,026	374,3	244,624
655	174,54	82,72	1,00	378,73	154,600	409,123	374,5	244,552
656	174,82	82,42	1,00	378,80	154,864	409,225	374,6	244,631
657	174,83	82,49	1,00	378,87	154,557	409,436	374,8	244,292
658	175,02	82,49	1,00	378,92	154,894	409,578	374,8	244,530
659	175,03	82,83	1,00	378,96	154,814	409,783	375,4	245,122
660	175,44	82,51	1,00	379,06	155,453	409,850	375,8	244,387
661	175,43	82,73	1,00	379,09	154,971	409,883	376,0	243,976
662	175,44	82,70	1,00	379,16	155,119	409,984	376,2	235,965
663	175,66	82,62	0,90	379,27	154,661	410,061	376,5	230,708
664	175,68	82,88	0,90	379,29	155,325	410,239	376,8	237,031

665	175,56	82,48	0,90	379,34	155,168	410,149	376,9	238,850
666	175,66	82,81	0,90	379,35	155,430	410,164	377,0	204,205
667	175,66	82,87	0,90	379,35	155,606	410,103	377,1	239,328
668	175,65	82,90	0,90	379,31	155,152	410,044	377,3	218,033
669	175,23	82,73	0,90	379,27	155,550	409,779	377,3	219,424
670	175,16	82,69	0,90	379,21	154,921	409,788	377,5	206,522
671	174,96	82,61	0,80	379,15	155,593	409,816	377,6	208,071
672	175,29	82,49	0,80	379,04	155,637	409,603	377,8	203,265
673	175,42	82,70	0,80	378,93	155,367	409,735	378,0	203,786
674	175,57	82,52	0,80	378,79	155,811	409,615	378,0	221,896
675	175,52	82,55	0,80	378,64	154,613	409,942	378,1	208,750
676	175,22	82,47	0,80	378,42	155,636	409,891	378,1	207,400
677	175,34	82,28	0,80	378,25	155,766	409,835	378,1	209,647
678	175,45	82,57	0,80	378,06	155,933	409,751	378,2	212,259
679	175,38	83,22	0,70	377,85	155,521	409,868	378,2	207,575
680	175,30	82,42	0,70	377,63	155,567	409,788	378,2	197,156
681	175,26	82,51	0,70	377,41	155,087	409,922	378,1	203,098
682	175,17	83,04	0,70	377,12	156,031	409,973	378,1	210,446
683	175,25	82,74	0,70	376,87	155,505	410,033	378,0	201,956
684	175,23	82,72	0,70	376,56	155,532	410,162	378,0	204,408
685	175,11	82,86	0,70	376,28	154,802	410,267	378,0	204,206
686	175,16	82,81	0,70	375,97	154,954	410,490	377,9	200,985
687	175,20	82,55	0,70	375,67	155,054	410,508	377,9	201,431
688	175,14	82,92	0,60	375,35	154,953	410,598	377,8	199,919
689	175,29	82,90	0,60	375,03	155,390	410,745	377,8	197,217
690	175,35	82,72	0,60	374,71	154,856	410,847	377,8	195,493
691	175,46	82,45	0,60	374,41	155,454	410,723	377,7	199,514
692	175,47	82,58	0,60	374,11	155,913	410,590	377,7	207,551
693	175,16	82,32	0,60	373,81	155,429	410,720	377,6	197,753
694	175,25	82,40	0,60	373,56	154,988	410,913	377,4	203,214
695	175,11	82,53	0,60	373,21	155,792	410,970	377,4	197,392
696	174,97	82,45	0,50	372,93	155,518	411,157	377,3	193,630
697	174,80	82,35	0,50	372,61	155,745	411,160	377,3	195,924
698	175,09	82,27	0,50	372,32	154,939	411,290	377,3	189,586
699	175,17	82,53	0,50	372,07	155,748	411,303	377,4	193,135
700	175,33	82,67	0,50	371,76	155,834	411,315	377,5	191,407
701	175,10	82,72	0,50	371,50	155,439	411,452	377,6	192,411
702	175,00	82,89	0,50	371,20	155,312	411,744	377,7	190,335
703	174,90	82,70	0,50	370,90	154,703	411,936	377,3	188,319
704	174,55	82,72	0,50	370,63	154,991	412,072	376,8	187,309
705	174,47	82,85	0,40	370,33	155,684	412,104	376,2	186,775
706	174,21	82,77	0,40	369,98	155,040	412,210	375,7	185,645
707	174,22	82,66	0,40	369,61	154,232	412,314	375,1	183,389
708	173,89	82,47	0,40	369,21	155,001	412,473	374,9	181,711
709	174,16	82,69	0,40	368,78	155,285	412,442	374,5	182,671
710	174,17	82,69	0,40	368,33	155,175	412,452	374,3	182,044
711	174,32	82,66	0,40	367,85	155,094	412,391	374,2	178,792
712	174,16	82,56	0,40	367,38	155,020	412,385	374,2	178,795
713	174,34	82,33	0,30	366,89	155,609	412,394	374,1	178,975
714	174,35	82,40	0,30	366,38	154,766	412,683	374,2	178,731
715	174,42	82,56	0,30	365,88	154,862	412,792	374,3	177,108
716	174,45	82,18	0,30	365,37	154,761	412,843	374,4	175,698
717	174,33	82,09	0,30	364,86	155,767	412,746	374,5	183,877
718	174,83	82,38	0,30	364,40	155,125	412,918	374,6	179,873
719	174,93	82,50	0,30	363,92	155,279	413,159	374,5	181,109
720	174,69	82,72	0,30	363,44	155,143	413,160	374,4	180,951
721	175,01	82,55	0,20	362,97	155,365	413,414	374,6	178,232
722	174,96	82,51	0,20	362,48	154,955	413,480	374,5	175,871
723	174,90	82,37	0,20	362,02	154,890	413,647	374,6	173,533
724	174,85	82,37	0,20	361,54	154,907	413,801	374,7	175,560
725	175,02	82,22	0,20	361,09	155,324	413,814	374,6	175,280
726	174,66	82,46	0,20	360,65	154,053	414,024	374,6	175,836
727	174,59	82,26	0,20	360,25	154,972	414,114	374,6	175,672
728	174,60	82,27	0,20	359,82	154,343	414,227	374,7	174,494
729	174,61	82,65	0,20	359,37	153,955	414,418	374,5	175,696
730	174,72	82,14	0,10	358,95	155,459	414,424	374,7	178,693
731	174,74	82,35	0,10	358,56	154,842	414,661	374,8	176,633
732	175,15	82,53	0,10	358,14	153,936	414,870	375,4	173,801
733	175,54	82,41	0,10	357,74	154,539	414,796	375,7	171,866
734	175,64	82,23	0,10	357,35	155,074	414,900	375,9	171,306
735	175,87	82,43	0,10	356,95	154,734	414,954	376,0	170,644
736	175,81	82,61	0,10	356,58	154,128	415,117	376,0	169,737
737	175,75	82,69	0,10	356,20	153,993	415,174	376,1	169,997
738	175,70	82,42	0,00	355,78	154,058	415,335	376,0	167,958
739	83,48	81,38	8,90	88,14	84,83	91,378	85,4	86,0163
740	116,00	81,54	8,90	87,93	84,91	91,330	90,6	86,0554
741	169,70	81,62	8,80	88,06	85,09	91,256	108,0	86,2244
742	204,34	81,28	8,60	89,29	85,86	91,173	125,7	86,7745
743	225,15	81,50	8,50	88,95	87,11	91,115	140,3	87,6668
744	262,88	81,51	8,30	89,50	88,56	91,073	160,1	88,6298
745	303,23	81,56	8,00	90,65	90,47	90,989	187,0	89,9487
746	341,65	81,79	7,90	92,37	92,69	90,929	221,7	91,6046
747	355,52	81,56	7,70	94,85	95,12	90,898	256,3	93,7312
748	388,53	81,69	7,50	98,04	97,64	90,859	289,8	96,1352
749	427,28	81,85	7,30	101,90	100,36	90,830	340,4	98,8795
750	414,47	81,90	7,10	106,49	103,63	90,854	384,7	102,1057
751	394,35	82,23	7,00	111,66	107,57	90,869	409,0	103,5750
752	379,54	82,46	6,80	117,37	111,69	90,973	421,6	105,5279
753	375,23	82,52	6,70	123,32	116,50	91,145	427,5	109,5275
754	390,75	82,13	6,60	129,31	120,62	91,360	446,0	113,2106
755	410,00	82,18	6,40	134,95	124,60	91,662	479,0	118,1136
756	416,05	82,14	6,30	140,53	128,09	92,022	504,4	121,9334
757	417,66	82,32	6,20	146,06	129,04	92,460	523,5	124,3387
758	419,12	82,15	6,00	151,36	129,48	92,991	536,8	128,4110
759	429,30	82,42	5,90	156,51	132,16	93,626	551,7	131,2851



760	442,50	82,44	5,70	161,89	135,51	94,320	563,1	134,9420
761	456,90	82,69	5,60	167,14	138,65	95,118	579,5	138,3593
762	465,82	82,42	5,40	172,43	143,53	95,994	599,9	142,0054
763	454,21	83,04	5,30	178,01	146,62	97,022	603,5	145,1233
764	448,86	82,92	5,20	183,68	149,95	98,084	606,7	148,5456
765	453,64	82,75	5,10	189,41	153,51	99,280	617,2	152,5029
766	451,91	82,53	4,90	195,34	156,46	100,578	624,2	154,8306
767	454,56	82,64	4,80	201,33	159,99	101,975	630,2	158,0038
768	453,43	82,78	4,70	207,49	163,11	103,470	633,8	161,1392
769	460,79	82,53	4,60	213,68	165,08	105,114	642,9	162,9385
770	476,64	82,86	4,40	219,87	167,59	106,828	658,4	165,3839
771	485,47	82,66	4,30	226,14	170,96	108,659	677,3	168,5393
772	480,30	82,87	4,20	232,49	173,45	110,700	683,3	171,1072
773	480,46	83,28	4,00	238,85	176,00	112,841	690,2	173,6813
774	485,18	83,11	3,90	245,24	178,76	115,102	701,3	177,2417
775	492,46	83,40	3,80	251,65	181,54	117,540	714,8	181,0712
776	490,25	83,30	22,79	258,12	184,92	120,093	701,4	183,3323
777	424,03	83,12	22,59	265,05	188,27	122,828	653,9	187,2280
778	388,70	83,16	22,49	272,38	188,60	125,759	610,8	187,5329
779	390,48	83,01	21,79	279,83	188,83	128,859	576,7	188,6581
780	394,31	83,06	21,79	287,15	189,05	132,072	548,6	190,8002
781	401,93	83,23	21,99	294,64	168,23	135,711	562,0	170,4715
782	395,57	83,40	21,79	301,53	152,86	139,092	572,7	153,5075
783	402,69	83,54	21,69	307,74	145,83	142,384	581,4	146,8908
784	418,75	82,89	21,59	313,25	141,76	145,575	595,3	145,9649
785	418,12	83,24	21,49	317,91	138,41	148,615	597,9	148,8248
786	410,80	83,11	21,39	321,95	139,35	151,468	595,7	144,0873
787	401,21	83,17	21,29	325,47	138,01	154,279	592,3	143,8826
788	393,81	83,62	21,19	328,49	138,27	156,976	586,8	144,2726
789	386,83	83,38	20,99	331,06	140,73	159,598	580,5	151,4763
790	381,07	83,58	20,99	333,16	141,49	162,133	574,4	179,1096
791	383,12	83,44	20,79	334,87	149,24	164,624	570,7	154,0457
792	391,22	83,18	20,69	336,15	147,42	167,114	570,5	155,3304
793	405,73	83,18	20,59	337,05	149,42	169,489	574,0	183,0497
794	422,90	83,33	20,49	337,68	148,75	171,870	586,0	182,4963
795	457,19	83,26	20,29	338,08	147,64	174,238	610,0	164,4827
796	498,82	83,34	20,09	338,33	148,17	176,537	651,8	161,5359
797	537,29	83,36	19,89	338,60	142,49	178,805	705,6	155,0886
798	559,10	83,79	19,59	338,94	140,59	181,137	758,3	152,3629
799	567,10	84,00	19,39	339,40	139,97	183,494	792,6	147,2690
800	571,73	83,84	19,19	340,07	140,97	185,807	820,5	146,0124
801	573,52	83,63	18,99	341,04	141,52	188,103	840,6	146,3032
802	576,71	84,10	18,79	342,18	143,15	190,416	853,7	147,2924
803	578,19	84,07	18,49	343,45	144,14	192,698	863,2	148,0809
804	577,34	84,14	18,39	344,81	144,48	195,014	870,1	149,5212
805	581,44	84,11	18,09	346,28	145,84	197,337	880,0	152,2143
806	582,10	84,04	17,99	347,82	147,26	199,548	889,2	151,1931
807	579,91	84,53	17,79	349,48	149,10	201,935	894,6	150,9432
808	576,41	84,53	17,59	351,25	148,56	204,368	898,2	150,3802
809	574,47	84,45	17,39	353,11	150,54	206,723	898,6	151,9918
810	572,85	84,30	17,19	354,97	151,10	209,181	899,46	152,6387
811	572,21	83,95	16,99	356,95	151,78	211,655	900,26	153,1421
812	571,59	84,19	16,89	359,00	154,173	214,227	901,71	154,6271
813	570,98	84,48	16,69	361,13	155,537	216,872	902,34	155,7849
814	571,14	84,16	16,49	363,30	156,458	219,546	903,99	156,7744
815	573,28	84,25	16,29	365,57	157,986	222,396	907,67	158,0118
816	575,09	84,50	16,09	367,87	159,014	225,236	910,43	159,0837
817	576,03	84,44	15,89	370,21	159,709	228,155	911,47	160,0676
818	577,62	84,54	15,79	372,63	160,818	231,002	915,39	161,6365
819	579,86	84,56	15,59	375,10	162,062	233,966	921,18	163,0545
820	581,29	84,81	15,39	377,64	163,089	236,898	925,23	164,1742
821	582,26	84,26	15,19	380,27	163,804	239,908	929,07	165,2147
822	580,10	84,97	15,00	382,91	162,916	242,958	930,92	164,8841
823	579,22	84,86	14,90	385,60	166,367	245,819	931,72	168,4626
824	579,29	84,79	14,70	388,31	166,545	248,627	935,25	168,9104
825	579,54	84,83	14,50	391,06	167,168	251,416	938,68	169,9713
826	581,65	84,92	14,30	393,88	169,654	254,144	944,81	172,3783
827	583,95	85,15	14,20	396,76	169,876	256,840	950,39	172,9271
828	587,09	85,35	14,00	399,73	172,482	259,563	956,96	175,8092
829	589,36	85,74	13,80	402,74	174,431	262,219	963,30	180,0001
830	589,00	85,49	13,60	405,81	175,618	264,950	965,65	182,0979
831	588,07	85,61	13,40	408,86	175,808	267,640	968,21	192,4873
832	588,42	85,49	13,30	412,00	177,012	270,265	971,30	191,9574
833	587,90	85,45	13,10	415,12	176,294	273,077	973,24	194,1419
834	588,18	85,58	12,90	418,28	178,852	275,593	975,88	196,8261
835	588,00	85,35	12,70	421,44	182,392	278,288	977,82	203,4400
836	588,47	85,38	12,60	424,62	182,946	280,845	978,64	208,1259
837	587,83	86,00	12,40	427,85	182,850	283,411	978,78	207,9534
838	588,17	85,67	12,20	431,14	182,825	285,960	981,57	208,4242
839	588,52	85,26	12,00	434,40	184,984	288,535	985,28	209,9465
840	589,47	85,57	11,90	437,70	185,696	291,047	987,90	211,0079
841	591,33	85,49	11,70	440,97	186,277	293,637	995,00	211,1364
842	592,12	85,58	11,50	444,23	187,337	296,208	1000,59	208,7325
843	592,98	85,82	11,40	447,53	188,625	298,745	1006,08	206,9304
844	593,50	85,88	11,20	450,82	190,587	301,326	1014,32	206,3312
845	593,61	85,98	11,00	454,08	191,761	303,917	1020,84	207,8270
846	593,50	85,93	10,90	457,44	191,670	306,551	1027,67	203,6724
847	593,64	85,86	10,70	460,80	192,998	309,374	1032,81	206,8532
848	593,75	85,86	10,50	464,15	194,314	312,063	1034,15	209,8843
849	590,06	85,89	10,40	467,49	194,819	314,728	1031,13	210,1832
850	585,05	85,93	10,20	470,83	195,431	317,388	1023,19	210,5318
851	581,01	86,09	10,10	474,23	195,805	320,071	1015,95	211,8362
852	577,27	86,21	10,00	477,58	197,030	322,593	1009,18	212,6356
853	574,77	85,91	9,80	480,91	196,735	325,130	1001,97	213,0135
854	573,97	85,73	9,70	484,14	197,490	327,653	998,52	216,7261

855	571,59	85,95	9,50	487,33	197,379	330,113	995,84	213,4790
856	569,79	86,12	9,40	490,44	197,834	332,492	993,61	211,6805
857	568,31	86,11	9,30	493,45	198,298	334,872	989,52	209,6168
858	566,13	86,15	9,20	496,45	198,783	337,437	986,49	209,1989
859	564,86	86,03	9,00	499,47	198,705	340,034	982,38	210,3201
860	563,18	85,96	8,90	502,59	201,598	342,626	977,35	214,9222
861	561,02	86,17	8,80	505,76	202,644	345,133	974,11	217,4136
862	560,23	85,99	8,60	509,05	202,851	347,679	971,75	216,5000
863	560,37	86,17	8,50	512,46	203,202	350,362	971,41	221,4483
864	560,33	86,20	8,40	515,86	203,679	352,968	972,33	217,7255
865	560,43	86,42	8,30	519,40	204,305	355,599	974,03	216,9261
866	560,77	86,25	8,10	522,98	204,464	358,435	976,47	218,2406
867	561,31	86,05	8,00	526,60	205,603	361,103	978,32	217,8572
868	562,06	85,81	7,90	530,31	205,779	363,838	982,00	218,1024
869	561,44	86,38	7,80	534,01	207,521	366,564	984,32	221,3319
870	561,53	86,24	7,70	537,70	207,514	369,419	988,53	219,1814
871	558,43	86,29	7,50	541,42	208,423	372,292	990,75	219,3393
872	552,16	86,21	7,40	545,16	208,969	375,071	989,53	220,0218
873	543,82	86,56	7,30	548,90	209,196	377,761	983,10	221,8903
874	537,37	86,54	7,30	552,57	208,072	380,308	976,03	218,5725
875	533,85	86,45	7,20	556,22	208,240	382,838	969,28	217,9967
876	532,14	86,72	7,10	559,89	208,161	385,586	960,86	218,9737
877	530,91	86,18	7,00	563,52	207,824	388,306	955,07	218,1403
878	528,60	86,45	6,90	567,11	207,889	391,202	949,35	216,6821
879	527,38	86,34	6,80	570,66	207,879	394,103	942,27	217,3280
880	526,89	86,37	6,70	574,20	208,142	397,135	938,28	217,7632
881	528,35	86,51	6,60	577,68	207,760	400,360	937,79	217,1821
882	529,57	86,60	6,50	581,17	208,404	403,585	936,48	217,7404
883	531,78	86,71	6,40	584,66	208,333	407,004	933,58	217,5634
884	532,43	86,28	6,30	588,19	209,757	410,378	930,32	219,1956
885	534,01	86,27	6,20	591,75	210,943	413,913	927,13	220,9973
886	533,96	86,44	6,10	595,45	211,132	417,589	923,60	220,1167
887	532,53	86,24	5,90	599,20	212,359	421,131	918,99	222,1566
888	531,26	86,60	5,90	603,08	213,156	424,772	914,00	224,0973
889	529,36	86,86	5,80	607,11	213,628	428,456	909,78	223,9133
890	526,39	86,73	5,70	611,19	214,040	432,288	907,56	224,9959
891	527,39	86,43	5,60	615,38	214,059	436,039	912,49	224,3480
892	526,44	87,10	5,50	619,60	214,058	440,035	918,83	225,1122
893	522,95	86,99	5,40	623,81	214,328	443,453	922,12	224,0550
894	517,81	87,21	5,40	617,30	215,183	447,008	919,05	224,3275
895	512,33	86,68	5,30	592,69	219,031	451,401	902,56	228,0354
896	499,47	87,02	5,30	574,84	218,606	454,973	885,19	228,4077
897	490,47	86,98	5,20	552,72	218,455	458,778	868,34	227,9730
898	482,09	86,96	5,20	532,01	216,877	462,585	850,31	227,1954
899	472,19	86,95	5,10	519,42	217,244	466,510	831,05	227,9665
900	463,74	86,74	5,10	501,69	216,659	470,010	811,87	228,5695
901	456,93	86,88	5,10	479,57	214,550	473,346	796,18	227,2591
902	451,69	86,58	5,00	471,50	215,595	476,663	782,01	227,5187
903	446,78	86,64	5,00	470,16	212,977	480,158	769,18	225,3874
904	441,83	86,85	5,00	468,08	214,533	483,475	757,18	228,3775
905	438,05	86,61	4,90	465,23	215,021	486,793	746,29	229,8543
906	433,90	86,87	4,90	464,09	213,865	490,112	736,10	229,7846
907	430,20	86,73	4,90	463,67	214,128	493,334	726,58	230,2210
908	426,95	86,67	4,80	462,49	213,566	496,363	717,40	229,2818
909	423,40	86,95	4,80	461,41	213,692	499,337	708,66	230,6728
910	419,95	86,74	4,80	460,67	213,012	502,087	700,21	230,8864
911	417,12	86,77	4,80	459,13	213,254	504,911	692,29	229,8035
912	413,83	86,80	4,70	457,34	212,716	507,443	684,53	228,5953
913	411,09	86,60	4,70	456,38	212,720	509,988	676,93	227,1425
914	407,64	86,67	4,70	456,07	212,247	512,572	668,94	227,6702
915	405,04	86,76	4,60	454,77	212,306	514,895	661,96	227,9779
916	402,08	86,90	4,60	452,98	213,245	517,556	655,50	229,8370
917	399,31	86,86	4,60	452,45	210,262	519,581	648,73	225,7701
918	396,79	86,57	4,60	451,90	210,300	521,761	642,62	226,2875
919	394,36	86,61	4,50	450,99	210,428	524,026	636,86	225,8207
920	392,37	86,19	4,50	450,23	209,111	526,300	631,22	224,0345
921	390,41	86,63	4,50	449,14	210,306	528,526	625,67	225,7741
922	388,58	86,82	4,50	447,16	207,857	530,878	620,47	223,3096
923	387,20	86,86	4,50	446,86	207,866	533,000	615,21	222,8102
924	385,25	87,05	4,40	445,56	208,513	535,179	610,63	223,1463
925	383,78	86,83	4,40	446,81	208,642	537,414	605,93	222,6179
926	382,05	86,62	4,40	449,28	208,128	539,278	601,73	222,6392
927	380,91	86,72	4,40	454,94	207,120	540,966	597,48	224,0556
928	379,19	87,11	4,30	462,22	208,504	542,979	593,54	225,4230
929	377,49	86,82	4,30	486,06	208,081	544,969	589,69	223,9899
930	376,17	86,88	4,30	522,61	207,087	546,834	586,07	226,3195
931	374,79	86,52	4,30	587,24	204,480	548,557	582,82	224,3707
932	373,29	86,71	4,20	608,33	205,381	550,208	579,64	224,9473
933	372,14	86,78	4,20	606,56	205,034	551,908	576,73	224,2991
934	371,19	86,97	4,20	604,37	204,967	553,510	573,87	223,6074
935	370,38	86,55	4,20	601,95	205,666	554,997	570,76	223,0805
936	369,05	86,75	4,10	599,47	204,472	556,300	567,72	222,3428
937	368,34	86,81	4,10	597,29	205,653	558,247	565,02	223,1007
938	367,11	86,80	4,10	594,95	202,950	559,707	562,02	220,3174
939	366,01	87,11	4,10	592,91	202,338	561,231	559,32	219,6713
940	364,93	87,03	4,00	589,62	203,492	562,846	556,85	220,5581
941	359,88	87,12	5,80	588,23	208,748	566,513	548,02	21,7000
942	331,73	87,25	21,69	586,10	224,965	572,877	520,62	259,6406
943	346,76	87,30	21,59	583,91	232,197	578,336	499,74	261,5854
944	362,34	86,91	21,39	580,98	226,519	580,205	488,50	254,6662
945	386,98	87,21	21,19	578,96	218,722	581,384	516,73	253,6847
946	448,45	87,08	20,99	575,92	215,494	582,746	572,10	250,0549
947	498,83	87,26	20,69	571,49	212,082	583,956	626,42	243,0837
948	538,98	87,41	20,39	567,08	209,952	584,839	678,62	237,9273
949	576,10	87,57	20,09	562,77	209,831	585,779	729,3	227,0369

950	606,68	87,56	19,79	523,14	212,230	585,933	777,4	222,2109
951	628,84	87,79	19,49	434,95	212,884	585,577	822,9	220,4580
952	644,38	87,86	19,29	444,75	215,361	585,375	861,7	220,7708
953	655,54	87,92	18,99	419,70	215,721	584,838	917,9	221,8571
954	664,59	87,71	18,69	428,04	216,340	584,023	946,2	221,9397
955	647,98	88,11	18,59	407,73	215,990	582,621	968,4	223,1215
956	585,79	88,24	18,29	412,24	216,438	581,402	976,6	223,3210
957	537,70	88,31	18,09	412,53	217,081	580,303	971,6	223,3343
958	512,41	88,15	17,89	409,76	216,209	578,932	966,7	223,3249
959	494,57	88,32	17,79	415,58	215,023	577,467	960,7	224,4028
960	482,75	88,16	17,59	407,53	213,661	576,188	957,6	224,3859
961	474,27	88,12	17,49	400,13	212,202	575,020	954,7	224,0199
962	467,73	87,90	17,29	394,83	212,172	573,280	951,6	224,4902
963	461,54	88,20	17,19	391,36	210,463	572,131	949,1	225,3274
964	457,98	87,94	16,99	388,65	214,198	570,604	948,4	229,5397
965	454,43	88,11	16,79	389,82	212,777	569,678	947,4	226,2727
966	450,85	88,01	16,69	389,32	213,194	568,094	947,1	226,7662
967	447,51	88,09	16,49	387,49	211,148	566,675	946,4	225,0136
968	445,33	87,92	16,39	387,16	209,067	565,805	945,3	225,1275
969	443,30	87,90	16,19	386,81	210,635	564,013	944,5	227,5220
970	441,21	87,32	16,09	389,54	209,827	562,175	944,1	226,3927
971	439,90	87,94	15,99	393,29	207,233	561,026	944,1	224,7222
972	438,62	88,44	15,79	395,32	210,024	559,478	944,6	228,7210
973	436,97	87,71	15,69	395,07	210,034	558,369	944,1	230,3038
974	436,12	88,05	15,49	393,46	208,988	557,578	945,3	227,9585
975	434,84	88,52	15,39	394,37	207,925	556,540	945,0	226,0705
976	435,46	88,62	15,19	397,39	205,709	556,154	946,2	224,3159
977	435,02	88,95	15,09	398,14	206,593	555,360	948,2	225,5329
978	434,61	89,10	15,00	398,47	206,369	554,857	949,5	225,0363
979	434,24	89,12	14,80	398,78	206,757	553,972	951,1	225,7034
980	434,04	89,33	14,70	398,69	206,540	553,722	952,9	225,1938
981	434,05	89,15	14,50	396,41	207,387	553,177	954,5	228,6078
982	434,15	88,97	14,40	398,23	208,172	552,656	956,7	228,0718
983	434,30	89,14	14,30	399,29	208,054	552,035	958,2	227,3356
984	434,38	88,95	14,10	401,44	208,823	551,431	960,0	227,7497
985	434,40	88,90	14,00	399,74	205,168	551,498	961,4	221,1606
986	434,65	88,30	13,80	397,12	208,540	551,109	963,3	221,0680
987	435,49	88,82	13,70	396,51	207,659	550,675	964,9	219,1604
988	436,02	88,61	13,60	395,19	210,301	550,255	966,3	220,8964
989	435,29	88,80	13,40	395,42	209,258	549,862	967,5	220,5097
990	436,06	88,71	13,30	394,23	206,283	549,613	969,0	217,6156
991	435,44	88,88	13,10	392,36	209,040	548,998	969,9	220,416
992	435,52	88,56	13,00	393,45	207,513	548,424	969,4	219,131
993	435,29	89,01	12,80	393,23	207,030	547,678	969,3	219,252
994	435,20	88,68	12,70	393,86	208,105	547,111	969,3	220,705
995	432,98	88,43	12,57	394,02	208,351	546,740	966,6	220,062
996	433,16	88,55	12,40	394,00	206,595	546,318	965,9	217,877
997	432,82	88,66	12,30	393,74	207,802	545,860	963,7	219,056
998	433,30	89,12	12,10	392,01	209,750	545,302	962,9	221,302
999	433,50	88,70	12,00	392,00	206,352	545,126	961,4	217,791
1000	432,36	88,84	11,80	390,92	208,015	544,935	960,4	221,199
1001	431,04	89,18	11,70	391,20	205,894	544,669	958,1	218,911
1002	431,06	89,06	11,50	390,82	207,391	544,087	958,1	221,665
1003	430,59	88,97	11,40	390,31	207,363	543,514	958,3	220,888
1004	428,70	89,09	11,20	391,00	207,188	542,712	957,1	219,146
1005	425,90	88,48	11,10	392,02	207,490	542,195	956,0	220,894
1006	424,15	88,88	11,00	392,86	206,562	541,747	954,7	219,735
1007	424,11	88,92	10,80	393,34	204,681	541,147	954,0	220,901
1008	423,18	89,22	10,70	393,67	205,015	540,595	953,5	219,836
1009	421,50	88,95	10,50	394,47	202,137	540,067	952,8	220,537
1010	420,50	88,70	10,40	394,83	204,545	539,574	951,6	222,227
1011	418,53	88,80	10,20	394,54	203,964	538,948	950,0	222,710
1012	418,81	89,02	10,10	395,51	202,285	539,004	952,4	219,981
1013	419,02	88,73	10,00	395,30	202,915	538,576	956,6	221,442
1014	419,03	89,24	9,90	396,35	203,178	538,346	960,2	219,490
1015	418,85	88,82	9,70	397,15	203,821	538,119	963,7	218,991
1016	419,73	88,94	9,60	396,47	205,179	537,665	966,7	222,374
1017	418,58	88,62	9,50	398,51	202,572	536,952	967,0	217,445
1018	419,56	88,73	9,40	398,53	202,033	536,624	970,3	217,733
1019	420,12	89,04	9,30	400,05	201,203	536,061	972,5	218,117
1020	419,29	88,81	9,10	399,64	201,588	535,517	972,7	217,869
1021	418,42	88,92	9,00	400,19	201,265	535,271	973,1	220,510
1022	417,42	89,02	8,90	401,07	198,466	535,168	972,7	218,973
1023	417,74	89,40	8,80	401,35	201,447	534,757	973,7	220,601
1024	418,05	89,03	8,70	402,18	199,906	534,292	973,1	217,471
1025	417,88	89,09	8,50	402,44	200,429	533,925	972,4	218,072
1026	418,41	88,98	8,40	402,88	201,707	533,538	973,1	218,513
1027	417,54	89,23	8,30	402,65	203,082	533,184	974,3	222,118
1028	415,98	88,97	8,20	404,08	203,426	532,424	976,2	221,585
1029	412,23	89,24	8,10	404,35	204,537	531,861	975,7	221,434
1030	407,87	89,11	8,00	403,45	202,398	531,548	970,9	217,203
1031	405,02	88,93	7,90	403,07	204,971	531,187	965,2	219,609
1032	401,28	89,12	7,80	403,75	203,309	530,426	957,1	217,109
1033	396,98	88,88	7,70	404,06	201,870	529,948	946,0	217,982
1034	392,63	89,01	7,60	404,51	202,014	529,496	933,4	217,730
1035	387,65	88,86	7,60	405,20	201,027	529,122	921,1	217,847
1036	382,53	89,12	7,50	405,63	201,414	528,712	907,6	218,963
1037	377,11	89,16	7,40	407,09	199,602	528,395	893,9	215,435
1038	372,40	88,76	7,30	407,28	201,047	527,772	881,2	218,753
1039	367,59	88,97	7,30	407,82	201,333	527,432	870,0	218,243
1040	364,78	89,03	7,20	408,37	201,827	526,448	859,7	217,897
1041	360,62	88,82	7,10	409,14	200,231	526,180	850,5	215,885
1042	357,72	89,20	7,10	408,99	198,893	525,776	842,4	216,077
1043	355,61	89,25	7,00	408,81	199,672	524,968	834,8	219,276
1044	353,60	88,68	6,90	408,90	197,796	524,736	828,2	219,614

1045	352,32	89,32	6,90	409,02	198,271	524,159	822,3	220,752
1046	350,82	89,13	6,80	408,91	198,245	523,054	816,8	222,510
1047	348,75	88,89	6,80	408,52	196,246	522,885	811,6	221,403
1048	348,05	89,14	6,70	408,73	196,093	522,325	807,0	220,519
1049	347,11	88,80	6,60	408,51	196,592	521,979	802,7	221,066
1050	346,48	88,91	6,60	407,82	195,776	521,722	798,5	220,089
1051	345,14	89,11	6,50	406,91	195,355	521,326	793,7	219,467
1052	344,00	88,80	6,40	406,60	193,909	521,131	789,4	218,723
1053	342,86	88,41	6,40	406,34	193,388	520,733	786,0	217,937
1054	341,35	88,71	6,30	405,54	190,959	520,669	781,3	215,895
1055	339,27	89,09	6,20	404,49	191,628	520,347	776,1	216,677
1056	337,78	89,04	6,20	404,44	191,552	519,922	771,1	216,416
1057	336,23	89,15	6,10	403,91	191,654	520,024	766,9	217,288
1058	334,17	88,93	6,10	403,26	191,029	519,634	762,5	216,766
1059	331,86	88,94	6,00	403,66	190,999	518,990	757,3	215,720
1060	329,44	89,07	6,00	404,46	189,880	519,006	752,1	214,502
1061	327,05	88,58	5,90	404,73	190,874	518,192	747,0	215,533
1062	325,61	88,90	5,90	406,66	189,670	517,563	741,7	215,856
1063	323,61	88,81	5,80	407,19	189,232	517,320	736,2	215,865
1064	322,18	88,39	5,70	408,09	189,573	517,104	731,3	216,400
1065	320,11	88,45	5,70	407,75	188,253	516,637	727,0	215,084
1066	318,87	88,62	5,70	408,68	188,032	516,281	722,8	215,206
1067	317,86	88,66	5,60	406,97	189,131	515,034	719,2	214,712
1068	315,85	88,23	5,60	407,20	189,299	514,652	715,6	214,163
1069	314,89	88,81	5,50	407,24	187,249	514,432	711,5	211,882
1070	313,61	88,14	5,50	406,03	188,508	513,982	707,2	213,435
1071	311,29	88,78	5,40	405,98	185,963	513,578	703,4	212,188
1072	308,68	88,58	5,40	407,53	188,251	512,990	699,1	214,880
1073	306,31	88,43	5,30	407,24	188,266	512,576	693,9	214,910
1074	303,58	88,17	5,30	411,90	187,185	512,186	688,2	213,979
1075	301,60	88,37	5,20	420,20	185,860	511,725	683,3	214,771
1076	300,07	88,40	5,20	429,68	185,441	511,458	678,5	215,872
1077	299,67	87,91	5,10	444,08	185,563	511,034	675,2	215,970
1078	299,23	87,91	5,10	449,65	184,154	510,971	672,3	216,664
1079	299,08	88,37	5,00	452,24	184,138	511,055	669,3	219,284
1080	297,97	88,01	5,00	445,83	183,229	511,008	665,7	218,798
1081	297,18	88,25	5,00	447,85	183,936	510,265	661,4	219,885
1082	295,85	88,40	4,90	447,10	183,444	510,248	657,3	221,075
1083	293,58	88,16	4,90	441,97	183,235	510,031	653,8	222,260
1084	292,35	88,05	4,80	442,42	183,116	509,807	650,3	221,338
1085	291,38	88,58	4,80	462,69	182,531	509,644	647,5	222,853
1086	290,54	88,37	4,70	463,88	182,711	509,757	644,5	223,569
1087	289,69	88,40	4,70	464,10	182,943	509,645	641,8	223,934
1088	289,35	88,03	4,70	443,01	181,368	509,572	639,2	223,527
1089	288,42	88,20	4,60	442,97	181,858	509,074	636,5	226,566
1090	288,16	88,72	4,60	443,10	181,339	508,884	634,1	228,086
1091	288,22	88,59	4,60	440,31	180,891	508,661	632,0	227,783
1092	288,08	88,37	4,50	440,02	181,949	508,165	631,1	226,356
1093	288,89	88,32	4,50	439,79	180,534	507,985	630,3	224,727
1094	289,52	88,23	4,40	437,17	181,333	507,510	629,5	226,010
1095	290,15	88,50	4,40	436,40	179,441	507,724	629,0	225,387
1096	290,45	88,09	4,30	434,01	178,751	507,777	629,1	224,179
1097	290,33	88,16	4,30	435,13	179,823	507,781	629,0	224,542
1098	288,83	88,14	4,30	432,57	178,889	507,793	628,2	226,007
1099	286,90	87,99	4,20	409,67	179,213	507,607	627,0	225,515
1100	283,95	88,09	4,20	401,03	178,258	507,803	624,6	223,073
1101	280,78	88,43	4,20	404,51	178,694	507,469	621,1	223,803
1102	277,32	88,00	4,20	405,39	178,017	507,295	617,1	224,558
1103	274,65	88,12	4,10	416,17	177,671	506,970	612,5	236,266
1104	272,31	87,88	4,10	471,38	178,587	506,801	608,1	229,228
1105	270,22	88,21	4,10	473,85	178,634	506,357	603,8	229,104
1106	267,67	87,86	4,10	468,91	177,846	506,156	599,3	226,315
1107	265,83	88,13	4,10	478,69	178,370	505,903	594,4	224,617
1108	263,67	88,36	4,00	469,20	177,922	506,352	589,0	225,896
1109	262,09	87,94	4,00	462,44	177,964	506,181	583,8	227,657
1110	261,16	87,97	4,00	426,22	177,861	505,829	579,3	244,498
1111	260,03	88,48	4,00	409,31	179,434	505,947	575,1	239,471
1112	258,66	88,10	4,00	402,09	180,440	505,826	570,5	242,055
1113	256,82	87,96	3,90	403,14	182,158	505,398	565,6	266,526
1114	255,42	88,02	3,90	393,55	182,042	505,134	561,1	314,675
1115	254,16	88,32	3,90	396,83	184,482	504,783	556,9	331,044
1116	253,01	87,70	3,90	407,05	185,339	504,903	552,2	300,872
1117	251,76	88,03	3,90	409,60	185,998	504,258	547,3	289,110
1118	249,99	88,15	3,90	400,59	186,214	504,304	542,5	316,882
1119	248,41	87,88	3,80	405,18	186,060	503,839	538,1	244,080
1120	247,47	88,03	3,80	401,76	186,101	503,531	533,8	273,817
1121	246,17	87,60	3,80	400,02	185,712	503,016	529,7	269,754
1122	245,11	88,04	3,80	394,92	185,125	503,147	525,8	329,389
1123	243,88	87,70	3,80	388,35	185,535	502,566	522,1	264,712
1124	242,87	88,10	3,80	382,12	184,319	502,393	518,6	301,574
1125	241,81	88,04	3,70	377,54	184,122	501,801	515,2	263,935
1126	240,84	87,98	3,70	367,03	184,047	501,679	511,9	225,929
1127	239,89	87,86	3,70	364,30	183,295	501,303	508,5	213,972
1128	239,04	88,03	3,70	358,77	183,151	500,833	505,1	209,181
1129	238,38	87,95	3,70	359,53	182,558	500,610	502,0	209,451
1130	237,14	87,78	3,60	358,73	182,890	500,536	499,0	220,364
1131	236,33	88,06	3,60	356,15	182,142	500,125	496,0	225,227
1132	236,27	87,59	3,60	350,96	181,819	499,471	493,2	227,327
1133	236,11	87,58	3,60	347,68	181,764	499,302	490,6	243,032
1134	234,80	87,52	3,60	343,44	180,845	499,064	488,1	254,662
1135	234,12	87,83	3,60	342,68	180,604	498,724	485,6	259,952
1136	233,42	87,64	3,50	340,78	180,118	498,441	483,2	248,809
1137	232,96	87,89	3,50	338,96	180,343	498,103	481,0	243,928
1138	232,02	87,71	3,50	335,93	179,627	497,825	478,7	230,959
1139	231,20	87,75	3,50	333,87	179,819	497,137	476,5	217,568

1140	230,30	87,55	3,50	332,18	179,338	496,423	474,3	216,744
1141	229,37	87,70	3,50	330,49	179,303	496,286	472,3	212,704
1142	228,92	87,18	3,50	328,48	179,725	495,919	470,0	212,398
1143	228,56	87,19	3,40	327,14	179,216	495,415	468,2	211,077
1144	228,23	87,26	3,40	326,12	178,899	495,075	466,5	215,578
1145	227,52	87,51	3,40	324,67	178,252	494,839	464,8	217,745
1146	226,91	87,73	3,40	323,13	178,454	494,407	463,3	218,145
1147	226,56	87,29	3,40	322,42	177,749	494,001	461,7	214,559
1148	226,86	87,43	3,40	321,17	177,970	493,804	460,2	212,708
1149	226,47	87,49	3,40	319,88	177,682	493,655	458,6	213,318
1150	226,22	87,58	3,30	318,65	177,618	493,196	457,2	214,434
1151	226,29	87,38	3,30	317,78	177,176	492,724	455,9	216,935
1152	226,02	87,18	3,30	316,44	177,275	492,324	454,7	215,357
1153	225,44	87,28	3,30	315,31	177,252	491,848	453,4	214,419
1154	224,61	87,40	3,30	314,63	176,904	491,505	452,0	213,088
1155	224,03	87,41	3,30	313,45	176,677	491,131	450,7	214,208
1156	223,72	87,23	3,30	312,80	176,910	490,354	449,5	213,659
1157	223,23	87,28	3,30	311,45	176,920	490,257	448,3	213,368
1158	222,85	87,22	3,20	311,19	176,385	490,435	447,0	211,791
1159	222,74	87,32	3,20	309,87	176,477	490,093	445,9	213,220
1160	222,32	87,45	3,20	309,31	176,763	489,661	444,8	213,600
1161	221,89	87,74	3,20	308,76	175,770	489,933	444,0	212,753
1162	221,38	87,09	3,20	307,45	176,065	489,740	443,0	218,219
1163	221,03	87,22	3,20	307,12	176,113	489,559	441,9	222,361
1164	220,55	87,05	3,10	306,46	175,507	489,441	440,7	228,001
1165	220,15	87,32	3,10	305,58	175,268	489,255	439,5	236,717
1166	219,80	87,17	3,10	304,64	175,030	488,991	438,3	267,787
1167	219,94	86,84	3,10	303,93	174,738	488,959	437,2	279,685
1168	219,74	86,94	3,10	303,34	174,901	488,723	436,2	306,090
1169	219,61	87,00	3,10	302,70	174,802	488,433	435,0	322,808
1170	219,16	87,01	3,10	302,20	174,666	488,028	433,9	322,429
1171	218,76	87,13	3,00	301,55	174,161	487,546	433,1	322,543
1172	218,13	87,11	3,00	300,50	174,119	486,972	432,1	316,771
1173	217,88	86,96	3,00	300,09	174,173	486,141	431,2	321,236
1174	217,36	86,95	3,00	299,11	174,257	485,408	430,1	321,497
1175	217,23	86,87	3,00	298,32	173,847	484,683	429,1	320,552
1176	216,61	86,90	3,00	297,63	173,454	484,005	428,4	320,486
1177	216,20	87,05	3,00	296,89	173,070	483,447	427,5	319,929
1178	215,96	87,05	2,90	296,13	172,761	482,595	426,7	319,298
1179	215,52	87,03	2,90	295,65	172,635	481,741	425,8	318,986
1180	214,92	87,07	2,90	294,73	172,463	481,122	424,7	318,819
1181	214,48	86,82	2,90	293,98	172,378	480,257	423,5	318,322
1182	214,29	86,85	2,90	293,48	172,475	479,705	422,5	318,310
1183	214,12	86,69	2,90	293,00	171,972	479,051	421,6	317,345
1184	213,79	86,76	2,90	292,46	171,854	478,529	420,6	317,373
1185	213,24	86,70	2,80	291,91	171,708	478,090	419,8	317,512
1186	213,17	86,99	2,80	291,71	171,298	477,759	418,9	316,691
1187	212,90	86,89	2,80	291,19	171,142	477,317	417,9	316,025
1188	212,72	86,54	2,80	290,67	171,277	476,839	416,9	316,330
1189	212,25	86,77	2,80	290,60	170,979	476,560	415,8	315,186
1190	211,73	86,91	2,80	290,38	170,941	476,283	414,7	315,515
1191	211,43	86,48	2,80	289,71	170,620	475,946	413,8	314,911
1192	211,09	86,51	2,80	289,11	170,654	475,710	412,8	314,477
1193	210,82	86,70	2,70	288,73	170,108	475,483	411,9	313,920
1194	210,62	86,57	2,70	288,37	169,906	475,156	411,0	313,052
1195	210,43	86,68	2,70	288,16	169,587	474,679	410,2	312,363
1196	210,12	86,66	2,70	287,57	170,167	474,305	409,5	312,829
1197	209,80	86,86	2,70	287,14	169,594	474,149	408,7	312,874
1198	209,80	86,81	2,70	286,60	169,095	474,007	408,0	311,918
1199	209,38	86,54	2,70	286,25	169,247	473,554	407,3	312,307
1200	209,36	86,50	2,70	285,74	168,810	473,354	406,6	311,376
1201	209,52	86,60	2,60	285,54	168,845	473,102	406,0	312,170
1202	209,06	86,72	2,60	285,22	168,524	472,754	405,5	311,071
1203	209,20	86,54	2,60	284,76	168,684	472,439	405,2	310,763
1204	209,27	86,30	2,60	284,27	168,923	472,196	404,8	310,371
1205	209,17	86,47	2,60	284,21	168,508	471,925	404,5	309,339
1206	209,07	86,46	2,60	283,87	168,508	471,605	404,2	309,105
1207	209,01	86,70	2,60	283,54	168,038	471,404	403,8	308,097
1208	208,78	86,43	2,50	283,13	168,474	470,795	403,4	308,523
1209	208,74	86,37	2,50	283,15	167,881	470,432	403,2	307,280
1210	208,49	86,37	2,50	282,80	167,662	470,168	403,0	306,245
1211	208,12	86,25	2,50	282,85	167,809	469,726	402,7	305,967
1212	208,37	86,26	2,50	282,07	167,794	469,229	402,5	305,131
1213	208,27	86,33	2,50	281,70	167,559	469,150	402,2	304,477
1214	208,40	86,37	2,50	281,53	167,672	468,748	401,9	304,443
1215	208,25	86,36	2,50	281,58	167,094	468,575	401,6	303,767
1216	208,12	86,34	2,40	281,52	167,198	468,536	401,4	303,642
1217	208,03	86,65	2,40	281,17	166,591	468,342	401,2	302,652
1218	208,01	86,31	2,40	280,71	166,993	468,397	400,9	302,548
1219	207,78	86,58	2,40	280,60	166,212	468,442	400,7	301,505
1220	207,41	86,53	2,40	280,86	166,019	468,425	400,5	300,841
1221	207,48	86,70	2,40	280,47	165,948	468,252	400,3	300,652
1222	207,29	86,53	2,40	280,47	166,060	468,341	399,9	300,196
1223	206,98	86,58	2,40	280,29	165,784	468,501	399,7	299,472
1224	207,19	86,40	2,30	279,99	165,519	468,250	399,4	298,856
1225	207,33	86,38	2,30	279,57	166,152	468,133	399,1	298,994
1226	207,41	86,60	2,30	279,44	165,406	468,120	398,8	298,063
1227	207,21	86,34	2,30	279,40	165,894	467,856	398,6	297,808
1228	207,17	86,44	2,30	279,31	165,029	467,830	398,4	297,173
1229	206,90	86,63	2,30	279,16	164,942	467,844	398,1	296,428
1230	206,88	86,66	2,30	278,90	164,757	467,556	397,9	295,996
1231	206,89	86,57	2,20	278,65	165,135	467,349	397,7	295,788
1232	206,56	86,37	2,20	278,35	165,621	467,418	397,5	295,811
1233	206,65	86,30	2,20	278,23	165,107	467,486	397,3	294,897
1234	206,78	86,42	2,20	278,25	164,680	467,516	397,0	294,585

1235	206,96	86,38	2,20	277,91	164,858	467,402	397,1	294,079
1236	207,12	86,13	2,20	278,04	165,109	467,387	397,0	294,078
1237	207,09	86,39	2,20	277,69	164,267	467,697	396,9	292,815
1238	206,92	86,26	2,10	277,77	164,370	467,864	396,8	292,403
1239	206,73	86,22	2,10	277,43	164,387	467,717	396,7	292,156
1240	207,16	86,67	2,10	277,33	164,376	467,787	396,6	291,716
1241	207,19	86,21	2,10	276,89	164,772	467,745	396,7	291,663
1242	207,14	86,12	2,10	276,97	164,507	467,871	396,6	291,133
1243	207,03	86,34	2,10	276,80	164,739	467,466	396,6	290,722
1244	207,18	86,25	2,10	276,66	164,285	467,702	396,5	289,995
1245	207,20	86,18	2,00	276,49	164,177	467,535	396,5	289,423
1246	207,45	86,13	2,00	276,32	164,712	467,423	396,6	289,585
1247	207,32	86,02	2,00	276,35	164,126	467,424	396,6	288,688
1248	207,62	85,99	2,00	276,17	164,091	467,459	396,7	288,116
1249	207,52	86,21	2,00	275,98	164,010	467,489	396,6	287,680
1250	207,56	86,23	2,00	276,18	163,643	467,545	396,5	286,888
1251	207,56	86,07	2,00	275,96	164,239	467,416	396,4	286,511
1252	207,61	86,26	1,90	275,96	164,218	467,409	396,3	286,068
1253	207,63	86,19	1,90	275,95	164,290	467,540	396,3	285,499
1254	207,69	86,35	1,90	275,52	164,678	467,559	396,2	285,355
1255	207,57	86,29	1,90	275,90	164,491	467,651	396,1	284,320
1256	207,84	85,86	1,90	275,52	164,752	467,733	396,2	284,039
1257	208,04	85,89	1,90	275,58	164,828	467,741	396,2	283,598
1258	207,80	86,00	1,90	275,76	164,422	467,767	396,2	282,161
1259	207,35	86,06	1,80	275,49	164,789	467,862	396,1	282,154
1260	207,58	86,19	1,80	275,66	164,298	468,219	396,0	276,246
1261	207,24	86,17	1,80	275,83	164,722	468,486	396,0	271,657
1262	207,24	85,92	1,80	275,39	164,917	468,767	395,9	235,547
1263	207,55	86,00	1,80	275,31	164,450	468,958	395,9	199,943
1264	207,17	85,90	1,80	275,45	164,625	469,539	396,0	195,050
1265	207,47	86,04	1,80	275,84	164,663	469,986	396,0	189,674
1266	207,89	86,08	1,70	275,95	165,110	470,329	396,3	187,405
1267	208,25	85,74	1,70	276,03	165,030	470,609	396,6	184,656
1268	208,26	85,93	1,70	276,25	165,268	471,189	396,6	183,662
1269	208,32	86,44	1,70	276,89	164,851	471,997	396,9	182,115
1270	208,09	86,35	1,70	276,89	165,204	472,478	396,9	181,412
1271	208,25	85,94	1,70	276,95	165,402	473,241	397,1	180,828
1272	208,48	86,12	1,60	277,10	165,336	473,416	397,4	180,240
1273	208,39	85,69	1,60	276,93	165,565	473,767	397,7	179,911
1274	208,32	86,08	1,60	277,07	165,692	474,277	397,9	179,622
1275	208,40	85,71	1,60	277,37	166,304	474,404	398,2	180,110
1276	208,74	85,57	1,60	277,03	166,392	474,548	398,5	179,447
1277	209,05	85,92	1,60	277,26	166,723	474,788	398,8	179,108
1278	209,13	85,67	1,50	277,61	166,789	475,286	399,3	178,481
1279	209,63	85,73	1,50	277,93	166,525	475,652	399,9	177,795
1280	209,99	85,75	1,50	277,78	167,056	475,854	400,3	177,453
1281	210,15	85,74	1,50	277,64	167,024	476,021	400,8	176,347
1282	210,74	85,86	1,50	277,92	166,832	476,357	401,3	175,651
1283	211,03	85,85	1,50	278,63	167,271	476,667	401,6	175,467
1284	210,80	85,60	1,50	278,39	167,164	476,769	401,9	174,771
1285	210,72	85,76	1,40	278,63	167,527	476,880	402,3	175,017
1286	210,91	85,76	1,40	278,85	167,635	477,108	402,4	174,058
1287	211,64	85,62	1,40	278,74	167,064	477,021	402,9	173,230
1288	211,52	85,56	1,40	279,11	166,622	477,312	403,3	173,294
1289	211,48	85,39	1,40	279,06	165,172	477,416	403,7	172,702
1290	211,58	85,47	1,40	279,42	164,590	477,704	404,1	172,429
1291	211,60	85,42	1,30	279,70	164,650	477,897	404,4	172,230
1292	212,32	85,85	1,30	279,90	165,821	478,124	404,9	172,376
1293	212,94	85,85	1,30	279,90	166,251	478,489	405,7	171,506
1294	213,13	85,72	1,30	280,18	166,073	478,740	406,3	171,248
1295	213,44	85,93	1,30	280,14	165,960	478,787	407,1	171,352
1296	213,24	85,87	1,30	280,14	166,236	478,999	407,7	171,788
1297	213,32	85,88	1,30	280,70	166,064	479,468	408,0	171,145
1298	213,63	85,68	1,20	280,98	167,389	479,716	408,3	170,829
1299	214,07	85,67	1,20	281,03	168,411	479,781	409,0	171,548
1300	214,36	85,48	1,20	281,06	169,039	480,015	409,7	171,445
1301	214,95	85,69	1,20	281,11	168,965	480,249	410,1	170,942
1302	215,15	85,61	1,20	281,55	168,728	480,613	410,9	171,027
1303	215,12	85,56	1,20	281,70	167,205	480,837	412,0	170,671
1304	215,36	85,75	1,10	282,28	168,922	481,240	413,1	170,492
1305	215,50	85,55	1,10	282,27	168,443	481,613	414,2	169,672
1306	215,63	85,75	1,10	282,25	167,174	481,792	414,9	170,397
1307	216,05	85,71	1,10	282,57	166,747	481,973	415,8	169,629
1308	216,17	85,76	1,10	282,82	168,083	482,186	416,7	170,333
1309	216,75	85,48	1,10	283,19	167,786	482,304	417,6	171,206
1310	217,05	85,52	1,00	283,39	167,422	482,434	418,0	170,601
1311	217,29	85,56	1,00	283,51	165,932	482,592	418,5	170,514
1312	217,47	85,70	1,00	283,90	167,507	482,836	419,1	170,364
1313	217,67	85,59	1,00	284,05	167,563	483,005	419,5	170,933
1314	217,67	85,91	1,00	284,62	167,770	483,216	420,0	170,927
1315	217,64	85,58	1,00	284,96	168,824	483,408	420,3	171,232
1316	217,52	85,47	0,90	285,28	168,418	483,400	420,6	170,744
1317	217,72	85,25	0,90	285,14	168,644	483,375	421,1	171,146
1318	219,01	85,53	0,90	285,91	168,292	483,288	423,1	170,945
1319	220,18	85,58	0,90	286,19	168,133	483,418	425,2	170,931
1320	221,09	85,70	0,90	286,46	168,531	483,207	426,9	172,159
1321	221,13	85,84	0,80	286,36	168,781	483,305	428,1	172,243
1322	221,60	85,49	0,80	286,73	167,943	483,192	429,3	173,644
1323	221,87	85,26	0,80	287,13	167,022	483,208	430,3	172,378
1324	222,78	85,29	0,80	287,35	167,608	483,104	431,6	173,513
1325	223,30	85,54	0,80	287,48	168,067	483,292	432,9	173,683
1326	223,31	85,42	0,80	288,07	168,875	483,686	434,1	174,529
1327	223,38	85,46	0,70	288,45	168,108	483,812	435,1	173,766
1328	223,80	85,60	0,70	288,41	167,417	484,230	436,0	174,359
1329	224,26	85,28	0,70	288,84	167,655	484,549	437,0	176,079

1330	224,79	85,45	0,70	289,00	166,800	484,860	438,0	175,837
1331	224,98	85,58	0,70	289,52	166,165	485,354	438,6	176,091
1332	225,02	85,65	0,70	289,50	167,011	485,803	439,3	177,702
1333	225,63	85,58	0,60	289,96	167,067	486,212	440,0	177,864
1334	225,50	85,37	0,60	290,56	165,302	487,006	440,4	176,482
1335	225,25	85,34	0,60	290,50	165,336	487,620	440,9	177,442
1336	225,40	85,56	0,60	290,75	165,962	488,265	441,1	178,299
1337	225,96	85,28	0,60	290,71	164,690	488,879	441,6	176,881
1338	226,24	85,36	0,60	291,06	165,828	489,472	442,1	178,093
1339	226,08	85,51	0,50	291,33	166,141	490,310	442,5	178,460
1340	226,36	85,61	0,50	291,86	165,293	491,239	442,8	177,792
1341	226,12	85,34	0,50	291,83	164,911	492,060	443,3	177,738
1342	226,08	85,26	0,50	292,35	165,417	492,951	444,3	178,754
1343	226,72	85,34	0,50	292,75	166,218	493,775	445,0	179,676
1344	226,90	85,37	0,50	292,71	165,676	494,582	445,8	178,964
1345	227,01	85,51	0,40	292,89	165,193	495,479	446,4	178,504
1346	227,27	85,00	0,40	292,98	164,908	496,325	447,0	178,042
1347	227,29	85,27	0,40	293,36	165,407	497,095	447,3	178,423
1348	227,23	85,42	0,40	293,43	165,912	497,673	447,7	178,876
1349	227,26	85,28	0,40	293,52	165,923	498,204	448,2	178,827
1350	227,28	85,14	0,40	293,75	166,527	498,718	448,4	179,400
1351	227,29	85,25	0,30	294,30	165,285	499,386	449,0	178,211
1352	227,31	85,16	0,30	294,37	166,197	499,735	449,1	179,301
1353	227,38	85,09	0,30	294,43	166,335	500,073	449,3	179,436
1354	227,37	85,05	0,30	294,41	165,858	500,626	449,7	178,863
1355	227,69	85,30	0,30	294,71	166,442	501,006	450,0	179,365
1356	228,15	85,20	0,30	295,00	165,355	501,391	450,5	178,220
1357	228,31	85,20	0,20	294,98	166,294	501,742	451,1	179,119
1358	228,49	85,23	0,20	295,12	166,662	502,045	451,5	179,763
1359	228,30	84,93	0,20	295,35	166,170	502,411	451,9	179,354
1360	228,61	84,99	0,20	295,56	165,651	502,744	452,0	179,188
1361	227,80	84,96	0,20	295,53	166,835	503,025	450,3	180,423
1362	228,99	85,15	0,20	295,15	167,227	503,157	448,8	180,762
1363	226,55	84,89	0,10	295,37	165,752	503,294	447,7	179,460
1364	225,80	85,19	0,10	294,95	166,388	503,362	446,4	180,112
1365	225,60	85,31	0,10	295,09	166,327	503,337	445,4	179,541
1366	225,52	85,35	0,10	294,94	164,541	503,143	444,3	178,796
1367	224,59	84,99	0,10	294,78	162,606	502,754	443,2	181,728
1368	224,40	85,09	0,10	294,22	163,171	502,139	442,0	185,874
1369	224,02	85,09	0,10	293,54	162,362	501,574	441,2	186,327
1370	223,43	84,82	0,10	293,02	162,416	500,783	440,2	185,485
1371	77,79	69,78	8,56	88,78	85,15	91,993	83,0	81,4210
1372	102,86	70,13	8,51	88,61	84,89	91,756	87,5	73,6245
1373	162,69	70,36	8,41	88,34	84,83	91,486	114,8	73,9869
1374	292,27	70,56	8,21	87,94	84,76	91,003	202,2	83,8181
1375	447,54	70,24	7,96	87,81	84,93	90,750	336,9	78,7633
1376	524,10	70,29	7,71	88,45	85,11	90,558	468,5	78,2940
1377	579,42	70,46	7,46	90,77	85,39	90,425	569,5	82,1615
1378	630,47	70,66	7,21	94,27	85,82	90,324	650,9	79,9750
1379	666,11	70,55	6,96	98,53	86,26	90,232	713,1	79,6292
1380	651,46	71,09	6,71	103,10	86,72	90,170	759,4	81,6814
1381	634,90	71,19	6,51	107,59	87,50	90,215	787,3	103,7745
1382	626,12	71,28	6,26	112,09	88,40	90,259	805,2	121,7691
1383	628,46	71,04	6,06	116,53	89,71	90,380	817,2	127,4891
1384	635,25	70,73	5,81	120,26	91,49	90,659	830,8	133,2389
1385	643,26	70,92	5,61	123,95	93,76	91,021	845,4	138,7711
1386	649,16	70,94	5,36	127,68	95,99	91,444	860,7	143,2740
1387	645,32	70,87	5,16	131,88	98,11	91,971	868,0	147,7365
1388	638,60	71,53	4,96	136,04	100,70	92,526	869,7	150,7608
1389	635,37	71,46	4,76	140,73	104,36	93,274	870,0	154,7540
1390	632,89	71,81	4,56	146,14	106,41	94,126	868,9	159,7851
1391	638,73	71,48	4,31	151,95	107,85	95,124	871,8	165,5005
1392	637,82	71,73	4,11	157,95	109,20	96,247	874,6	171,7175
1393	630,19	71,62	3,96	164,32	111,40	97,535	873,8	178,1281
1394	621,97	71,55	3,76	170,64	114,77	98,952	871,1	184,4226
1395	616,12	71,54	3,61	177,41	118,51	100,495	868,2	191,0270
1396	604,21	71,66	3,46	184,11	123,82	102,140	859,0	197,8190
1397	601,42	71,25	3,31	191,09	131,06	103,916	849,5	204,6185
1398	599,62	71,56	3,16	198,10	140,47	105,814	842,2	211,6146
1399	600,38	71,36	3,01	205,46	145,79	107,771	841,1	218,3422
1400	597,13	71,58	2,86	212,32	153,85	109,839	838,5	225,1368
1401	597,50	71,92	2,71	219,40	176,57	112,265	839,5	232,0544
1402	512,51	72,03	19,92	228,01	211,99	115,000	799,6	239,8776
1403	502,85	71,63	19,82	234,86	219,48	117,611	767,5	246,9581
1404	480,66	71,55	19,67	241,42	227,14	120,503	742,5	253,6165
1405	463,98	71,58	19,57	247,93	234,76	123,496	721,9	259,9380
1406	439,56	71,37	19,47	253,77	242,08	126,490	700,4	265,7560
1407	426,06	71,27	19,37	258,50	248,94	129,723	673,1	270,7711
1408	464,51	71,09	19,22	262,99	255,25	132,838	666,3	274,9417
1409	561,52	71,20	18,97	266,83	260,90	136,036	712,1	278,5469
1410	615,32	70,82	18,77	270,08	265,97	139,180	770,8	281,7248
1411	639,01	71,37	18,52	272,38	270,54	142,265	817,9	284,2413
1412	656,42	71,54	18,27	277,93	256,10	146,010	854,7	288,7592
1413	662,53	71,76	18,02	282,01	245,14	149,198	879,4	293,1791
1414	663,17	71,90	17,77	285,91	236,34	151,424	896,1	297,1387
1415	667,37	72,22	17,52	289,92	229,14	153,003	905,7	300,7665
1416	672,45	72,13	17,27	293,92	222,94	154,522	913,6	303,8214
1417	669,54	71,58	17,07	297,96	217,95	155,791	916,95	306,4936
1418	671,50	71,84	16,82	302,03	162,66	156,927	920,61	308,9185
1419	678,44	71,92	16,57	306,23	151,126	157,800	925,27	311,2601
1420	678,96	72,18	16,32	310,49	148,005	158,816	929,75	313,5723
1421	679,44	72,15	16,07	314,88	146,591	159,769	934,59	315,6723
1422	685,80	72,25	15,82	319,34	145,653	160,851	942,51	317,8882
1423	691,87	72,43	15,61	323,97	144,712	161,784	951,37	320,2086
1424	695,64	72,31	15,32	328,64	143,727	162,799	959,08	322,4238

1425	699,49	72,79	15,12	333,55	143,727	163,590	966,24	324,7452
1426	699,72	72,25	14,87	338,48	143,864	164,804	971,67	327,0634
1427	698,69	72,24	14,61	343,67	143,741	165,830	975,52	329,5152
1428	696,71	72,55	14,36	348,94	144,142	166,780	977,89	332,2464
1429	692,50	72,63	14,11	354,28	144,944	167,835	978,95	335,0877
1430	687,19	72,72	13,91	359,71	145,272	168,741	977,88	338,0934
1431	681,75	72,54	13,66	365,18	146,267	169,772	975,63	341,3042
1432	682,16	72,58	13,46	370,73	146,885	170,797	973,75	344,5833
1433	678,45	72,74	13,21	376,29	147,351	172,064	971,72	348,1136
1434	672,24	72,61	13,01	381,90	147,879	173,053	968,31	351,5451
1435	666,71	72,25	12,81	387,45	148,688	174,438	964,23	355,0253
1436	663,54	72,34	12,61	392,90	149,526	175,521	959,62	358,5886
1437	659,56	71,86	12,41	398,24	149,890	176,815	957,09	362,3532
1438	656,28	72,21	12,21	403,39	150,977	178,037	954,40	366,0420
1439	654,34	72,57	11,96	408,45	151,414	179,027	951,76	369,7773
1440	652,84	72,58	11,81	413,34	152,587	180,209	949,22	373,4954
1441	649,73	72,36	11,61	418,06	154,965	181,620	946,57	377,1521
1442	647,69	72,50	11,41	422,59	157,248	182,771	943,95	380,9094
1443	644,47	72,63	11,21	426,93	157,114	183,873	941,65	384,7775
1444	641,22	71,40	11,01	431,15	158,355	185,004	938,71	388,3494
1445	638,65	72,17	10,86	435,30	159,909	186,213	935,59	392,1220
1446	638,59	72,04	10,61	439,36	162,097	187,392	934,51	395,5919
1447	638,98	71,70	10,46	443,26	167,536	188,491	934,23	399,1704
1448	638,44	72,26	10,26	447,05	168,143	189,652	934,00	402,6332
1449	638,03	72,08	10,06	450,80	169,035	190,773	934,50	406,1621
1450	637,28	72,16	9,91	454,49	169,786	191,973	934,12	409,7386
1451	635,01	71,53	9,71	458,12	170,716	193,294	933,09	413,0230
1452	634,66	72,23	9,51	461,76	171,820	194,309	932,23	416,7253
1453	634,42	72,50	9,36	465,38	173,074	195,483	931,62	420,3902
1454	634,12	72,40	9,16	468,87	173,228	196,535	931,95	424,1194
1455	632,41	72,38	9,01	472,38	174,439	197,633	931,53	427,7253
1456	629,35	72,53	8,81	475,90	175,313	198,925	930,13	431,3605
1457	626,48	72,32	8,66	479,44	175,909	200,152	924,73	435,1502
1458	621,37	72,38	8,51	482,96	178,093	201,261	915,90	438,9102
1459	619,41	72,64	8,36	486,48	222,084	202,413	908,21	442,5345
1460	617,25	72,45	8,21	489,86	207,928	203,554	902,25	446,1423
1461	617,24	71,92	8,01	493,14	238,500	204,801	898,08	449,6382
1462	618,14	71,96	7,86	496,30	213,174	205,736	897,94	453,0959
1463	616,66	72,22	7,71	499,34	207,202	206,915	896,54	456,4689
1464	616,47	72,05	7,56	502,20	202,431	208,141	894,27	459,5944
1465	616,51	72,17	7,41	504,89	242,099	209,230	892,99	462,7371
1466	613,79	72,38	7,31	507,51	227,247	210,458	891,93	465,9340
1467	614,48	71,95	7,16	509,98	253,412	211,649	891,50	469,0077
1468	613,09	71,75	7,01	512,36	254,289	212,968	890,65	471,9494
1469	612,54	72,16	6,86	514,70	259,903	214,228	888,10	474,6658
1470	611,94	71,56	6,71	516,76	262,120	215,538	886,25	477,5735
1471	611,48	72,12	6,56	518,80	263,194	216,727	884,62	480,2918
1472	609,48	71,91	6,41	520,77	266,599	218,071	883,19	482,9296
1473	608,01	72,44	6,31	522,58	269,025	219,197	880,84	485,6064
1474	605,67	71,95	6,16	524,30	271,752	220,579	877,88	488,2382
1475	603,32	72,51	6,01	526,07	274,182	221,865	874,30	490,7689
1476	599,56	72,46	5,91	527,59	276,810	223,131	870,08	493,3195
1477	592,12	72,42	5,76	528,96	279,730	224,463	863,71	495,7184
1478	584,93	72,41	5,66	530,31	282,669	225,814	854,27	498,1918
1479	576,46	72,43	5,56	531,53	285,630	227,127	842,85	500,7682
1480	568,95	72,42	5,46	532,62	288,883	228,505	830,25	503,1804
1481	562,20	72,42	5,41	533,59	291,949	229,888	818,54	505,5634
1482	557,07	72,30	5,31	534,46	295,142	231,172	807,40	507,7974
1483	550,98	72,33	5,21	535,03	298,936	232,664	796,09	509,8355
1484	546,11	72,22	5,11	535,46	302,333	234,205	785,40	511,4725
1485	541,93	72,00	5,06	535,94	305,714	235,757	776,04	513,1174
1486	538,55	71,65	4,96	536,20	309,196	237,263	767,78	514,4525
1487	535,99	71,38	4,86	536,43	312,486	238,903	760,79	515,2729
1488	533,04	71,31	4,81	536,55	315,543	240,514	753,96	516,3091
1489	528,23	71,62	4,71	536,46	318,555	241,560	746,94	517,0989
1490	521,95	71,23	4,66	536,32	321,335	243,029	738,78	517,7313
1491	517,13	71,19	4,56	536,13	323,863	244,825	729,86	518,3212
1492	512,67	71,74	4,51	535,87	326,048	245,764	721,04	518,7806
1493	508,43	71,72	4,46	535,49	328,442	246,976	712,87	519,0748
1494	505,13	71,44	4,41	534,98	330,499	248,573	705,18	519,1597
1495	500,51	71,52	4,36	534,37	332,523	250,005	697,55	519,1993
1496	491,32	71,56	4,26	533,46	338,850	252,822	685,72	518,7968
1497	570,42	71,47	20,37	504,89	464,563	287,280	789,78	492,2782
1498	570,42	71,47	20,37	504,89	464,563	287,280	789,78	492,2782
1499	570,42	71,47	20,37	504,89	464,563	287,280	789,78	492,2782
1500	570,42	71,47	20,37	504,89	464,563	287,280	789,78	492,2782
1501	570,42	71,47	20,37	504,89	464,563	287,280	789,78	492,2782
1502	570,42	71,47	20,37	504,89	464,563	287,280	789,78	492,2782
1503	570,42	71,47	20,37	504,89	464,563	287,280	789,78	492,2782
1504	596,59	71,34	20,12	500,80	472,936	291,171	817,33	487,5016
1505	646,96	71,08	19,82	497,54	479,856	294,738	851,92	483,1436
1506	647,71	71,79	19,57	493,00	485,490	298,513	872,36	478,0826
1507	647,98	71,25	19,32	490,06	489,961	301,276	887,79	473,5388
1508	650,36	71,24	19,07	487,46	493,498	304,082	898,88	469,0885
1509	650,30	71,94	18,82	485,61	496,219	307,347	908,79	464,8084
1510	625,12	72,10	18,62	484,23	498,305	310,320	912,51	461,4666
1511	592,61	71,53	18,42	482,40	499,867	313,179	908,99	457,9447
1512	525,54	71,83	18,27	482,00	500,944	315,497	904,57	455,3391
1513	480,81	71,53	18,17	481,52	501,683	317,692	894,33	453,4697
1514	454,43	70,90	18,02	481,23	502,091	319,608	881,94	451,3828
1515	434,74	71,07	17,92	480,82	502,127	321,768	869,96	449,5552
1516	419,09	71,58	17,82	480,59	501,993	323,885	856,12	447,3383
1517	407,65	71,62	17,72	479,33	501,415	325,631	845,79	445,6170
1518	399,78	71,22	17,62	478,27	500,728	327,471	836,45	443,2332
1519	394,58	71,22	17,47	477,00	499,890	328,621	831,02	440,7828



1520	390,75	71,22	17,37	475,56	498,891	329,443	825,96	438,2497
1521	387,05	70,71	17,27	474,09	497,764	330,520	823,61	435,6967
1522	385,89	70,73	17,17	472,01	496,552	331,221	824,01	432,8973
1523	385,26	70,73	17,02	470,32	495,200	331,971	826,59	429,9040
1524	384,88	70,76	16,92	468,08	493,703	332,664	826,49	427,2121
1525	385,76	70,78	16,77	466,33	496,026	333,113	825,27	424,2208
1526	387,42	70,80	16,67	463,64	492,677	333,896	824,62	421,1172
1527	389,01	70,20	16,52	461,75	444,120	333,764	824,97	418,6342
1528	393,68	70,17	16,41	459,99	427,313	334,250	828,55	415,6032
1529	396,92	70,19	16,27	457,84	405,881	334,366	833,96	412,9995
1530	398,88	70,25	16,17	456,28	410,866	334,059	837,65	410,3288
1531	399,72	70,37	16,01	454,15	392,902	334,450	840,12	407,4243
1532	401,55	70,18	15,86	452,45	390,513	334,295	843,67	404,6184
1533	403,44	70,48	15,76	451,59	384,385	334,431	848,37	402,6860
1534	404,74	70,48	15,61	449,37	380,276	333,807	852,86	400,3046
1535	404,60	71,07	15,47	448,16	375,647	333,341	858,33	397,9231
1536	406,68	71,43	15,36	446,72	373,722	333,153	863,99	395,8308
1537	407,76	71,40	15,21	445,66	374,197	332,834	869,36	393,8050
1538	407,74	72,20	15,06	445,01	375,309	332,916	873,71	391,8300
1539	408,10	72,14	14,96	444,31	374,199	332,529	876,64	389,9036
1540	407,33	72,32	14,81	443,04	372,638	332,536	878,77	388,1651
1541	407,08	72,14	14,71	442,19	372,137	332,041	880,68	386,5319
1542	406,95	72,51	14,56	441,81	372,054	331,425	882,75	384,9601
1543	406,85	72,27	14,41	441,20	370,757	330,964	884,32	383,5762
1544	406,72	71,98	14,31	440,11	369,357	330,499	885,51	382,1378
1545	407,35	72,18	14,16	439,73	368,460	330,320	886,49	380,5580
1546	406,65	72,17	14,01	439,12	367,660	329,788	885,51	379,2590
1547	405,86	71,94	13,91	438,79	364,732	329,300	884,11	378,1302
1548	404,19	71,79	13,76	438,38	362,581	328,755	882,24	376,8705
1549	402,07	71,92	13,66	438,04	362,520	328,511	879,46	375,8635
1550	400,10	71,80	13,51	437,76	361,749	328,055	877,98	374,8004
1551	399,05	71,80	13,41	437,65	360,690	327,558	877,53	373,7964
1552	398,72	71,71	13,31	437,68	360,662	326,952	877,96	372,8257
1553	397,26	71,39	13,16	437,33	360,926	326,156	878,09	371,9504
1554	396,52	71,39	13,06	436,89	359,999	325,683	876,41	371,1401
1555	398,28	71,63	12,96	436,75	357,725	325,098	874,12	370,2577
1556	399,77	71,69	12,81	436,56	357,170	324,586	873,5	369,5017
1557	400,61	71,75	12,71	436,35	356,250	323,990	875,1	368,9801
1558	401,44	71,56	12,61	435,71	355,552	323,314	877,2	368,1337
1559	402,71	71,41	12,46	435,60	355,095	322,715	880,3	367,6125
1560	403,25	71,16	12,31	435,27	354,810	321,668	881,9	367,1620
1561	403,52	71,14	12,21	435,15	354,911	321,084	882,6	366,7184
1562	404,72	71,08	12,11	434,50	353,924	320,718	884,2	366,2080
1563	408,26	71,43	11,96	434,46	353,451	320,292	886,1	365,7331
1564	407,90	71,47	11,86	434,27	352,985	319,665	888,3	365,4529
1565	404,81	71,40	11,76	434,27	352,470	319,342	887,6	365,2050
1566	400,28	70,84	11,66	434,41	352,337	318,394	883,6	365,2432
1567	395,82	71,11	11,51	434,42	352,414	318,028	877,4	364,8980
1568	392,69	70,90	11,41	434,69	350,580	317,575	871,6	364,8868
1569	389,05	71,36	11,31	435,36	351,827	316,820	866,0	364,6929
1570	387,42	71,38	11,21	435,69	352,364	316,193	861,0	364,4131
1571	385,57	71,32	11,11	436,38	352,329	315,591	856,8	364,3205
1572	383,82	70,88	11,01	437,00	353,581	315,246	853,0	364,2963
1573	381,65	70,89	10,91	437,26	354,433	314,487	849,4	364,5364
1574	380,54	71,12	10,81	437,95	356,940	314,287	845,7	364,3723
1575	379,62	70,66	10,66	438,84	356,913	313,550	842,0	364,2858
1576	378,57	70,64	10,56	439,18	357,390	312,974	838,6	364,5555
1577	376,86	70,57	10,46	440,21	357,116	312,694	834,0	364,5872
1578	376,40	70,60	10,36	440,80	361,443	312,064	829,6	364,4924
1579	376,27	70,26	10,26	441,43	360,812	311,780	826,4	364,7532
1580	375,18	70,23	10,16	442,63	360,860	311,089	823,8	364,8569
1581	374,56	70,11	10,06	443,07	360,445	310,685	821,5	364,8903
1582	374,04	70,46	9,96	443,84	359,830	310,704	819,1	364,8749
1583	372,50	70,36	9,86	444,35	360,995	309,961	816,9	364,9602
1584	371,27	70,61	9,76	445,20	360,893	309,792	814,9	364,9876
1585	369,90	70,87	9,66	446,27	361,512	309,318	812,7	365,0882
1586	369,64	70,57	9,56	446,62	363,177	309,141	810,8	365,3210
1587	369,09	70,68	9,41	447,44	364,773	308,680	809,6	365,3987
1588	369,53	70,51	9,36	448,12	364,624	308,420	808,8	365,5486
1589	369,49	70,95	9,26	448,82	364,504	308,186	807,8	365,7305
1590	368,66	70,90	9,11	449,36	364,291	308,064	807,6	365,9028
1591	368,75	70,89	9,06	450,28	363,936	307,740	807,7	365,8296
1592	367,89	70,88	8,96	450,77	364,418	306,997	807,4	365,9295
1593	367,03	71,08	8,86	451,70	364,619	307,007	807,6	366,2672
1594	365,72	71,41	8,76	451,96	364,171	306,911	807,6	366,4377
1595	365,88	71,17	8,66	452,66	363,978	306,645	807,7	366,4448
1596	365,84	71,12	8,56	453,54	363,917	306,342	808,3	366,8312
1597	364,86	71,31	8,46	454,03	363,992	306,340	808,5	366,9241
1598	364,43	71,03	8,41	454,78	363,996	306,111	809,1	366,823
1599	363,84	71,44	8,26	455,11	363,962	305,733	809,0	367,079
1600	364,01	71,43	8,16	455,98	363,777	305,571	808,9	367,287
1601	363,89	70,89	8,06	456,24	364,826	305,201	808,0	367,505
1602	363,06	70,63	8,01	456,64	365,241	305,053	807,3	367,724
1603	362,06	70,61	7,91	457,25	366,044	304,513	806,5	368,197
1604	361,41	70,79	7,81	457,96	365,751	304,429	805,5	368,501
1605	361,80	70,63	7,71	458,03	365,687	304,035	804,5	369,044
1606	360,99	70,69	7,61	458,53	366,148	304,151	804,1	369,035
1607	361,14	70,49	7,56	459,02	366,201	304,088	803,4	369,406
1608	361,29	70,54	7,46	459,50	366,828	303,994	804,2	369,740
1609	360,45	70,32	7,36	459,88	366,313	303,665	803,3	370,435
1610	359,57	70,66	7,26	461,14	368,849	303,562	801,7	370,507
1611	357,65	70,48	7,16	460,96	372,730	302,935	799,1	371,131
1612	356,27	70,33	7,11	461,49	377,606	302,698	796,2	371,495
1613	354,08	70,47	7,01	461,84	377,961	302,523	793,2	371,854
1614	351,93	70,46	6,91	462,59	375,186	302,771	789,4	372,431

1615	349,92	70,47	6,86	462,74	376,496	302,585	785,5	372,814
1616	348,42	70,70	6,76	462,93	376,402	302,758	780,4	373,246
1617	345,48	70,15	6,71	463,07	381,586	302,716	774,8	373,758
1618	343,70	70,55	6,61	463,38	382,092	302,543	769,5	374,255
1619	341,68	70,62	6,56	463,37	382,143	302,495	764,8	374,867
1620	339,83	70,78	6,46	463,38	382,499	302,684	760,4	375,340
1621	339,02	70,66	6,41	463,60	383,022	302,724	756,6	375,575
1622	338,49	70,48	6,31	463,57	397,215	302,550	752,9	376,216
1623	337,15	70,85	6,26	463,77	395,861	302,517	750,0	376,590
1624	337,24	70,97	6,21	464,04	396,396	302,675	747,8	376,957
1625	337,02	70,91	6,11	463,29	396,949	302,659	746,0	377,316
1626	337,71	70,62	6,01	463,41	399,539	302,580	745,7	377,773
1627	338,30	70,70	5,96	463,01	402,108	302,424	746,1	378,338
1628	339,17	70,61	5,91	462,97	401,738	302,403	746,4	378,750
1629	339,33	70,67	5,81	462,52	402,011	302,542	747,4	379,214
1630	340,21	70,86	5,71	462,05	402,083	302,725	748,8	379,595
1631	339,39	70,91	5,66	461,81	402,573	302,882	749,5	380,183
1632	336,19	70,79	5,56	461,83	404,938	302,623	746,1	380,492
1633	335,30	70,65	5,51	461,22	404,148	302,934	742,9	381,054
1634	335,00	70,87	5,41	461,00	405,798	303,085	740,9	381,770
1635	334,97	70,46	5,36	460,60	406,637	302,893	739,2	382,304
1636	335,19	70,59	5,26	460,51	408,422	302,648	738,9	383,002
1637	335,72	70,76	5,21	459,92	410,824	302,643	738,7	383,495
1638	336,80	70,73	5,11	459,62	411,740	302,996	740,6	384,152
1639	339,12	70,70	5,06	459,16	411,986	303,334	743,4	384,814
1640	342,92	70,80	4,96	458,59	412,421	303,249	748,5	385,411
1641	345,38	70,81	4,91	458,21	413,873	303,388	753,6	386,173
1642	345,19	70,43	4,86	457,61	414,259	303,323	755,7	386,821
1643	344,54	70,79	4,76	457,02	413,646	303,579	756,4	387,602
1644	343,60	70,52	4,71	456,66	414,581	303,572	756,6	388,608
1645	343,74	70,55	4,61	456,19	415,236	303,414	757,8	389,449
1646	344,38	71,05	4,56	455,78	414,741	303,657	759,3	390,540
1647	344,61	71,00	4,51	455,13	417,945	303,777	761,7	391,677
1648	345,73	70,94	4,41	454,91	417,917	303,866	764,9	392,923
1649	345,84	71,04	4,36	454,41	418,547	303,795	767,8	394,293
1650	346,48	70,80	4,31	453,63	421,510	303,871	771,1	395,856
1651	345,80	70,57	4,26	453,47	419,390	303,792	772,5	397,263
1652	345,35	70,74	4,16	452,64	419,441	304,135	773,0	399,100
1653	345,35	71,06	4,11	452,19	419,040	304,286	774,5	400,633
1654	344,83	71,26	4,06	451,85	419,069	304,470	776,2	402,172
1655	344,47	71,33	4,01	451,36	423,720	304,738	777,8	403,956
1656	344,06	71,44	3,91	451,15	424,921	304,611	778,5	405,429
1657	341,90	71,29	3,91	450,76	425,692	304,623	778,5	407,385
1658	338,52	71,57	3,86	450,43	426,981	304,831	775,9	409,242
1659	334,45	71,38	3,81	450,17	426,738	304,953	770,1	410,894
1660	330,54	71,29	3,76	449,73	430,579	305,177	763,1	412,713
1661	327,18	71,33	3,71	449,49	433,908	305,459	756,0	414,785
1662	323,58	71,70	3,71	449,29	433,824	305,715	748,9	416,598
1663	319,79	71,33	3,66	449,09	439,422	305,659	742,1	418,420
1664	316,34	71,25	3,61	448,97	446,373	305,831	735,2	419,789
1665	312,89	71,57	3,61	448,46	450,312	306,058	728,2	421,824
1666	308,82	71,26	3,56	448,29	453,577	306,068	719,9	423,356
1667	303,88	71,37	3,56	447,80	444,252	306,344	711,2	425,108
1668	299,20	71,30	3,51	447,67	434,648	306,506	702,7	426,647
1669	295,69	71,22	3,51	447,45	426,090	306,718	694,8	428,433
1670	292,31	71,32	3,46	447,04	400,240	306,902	687,3	429,905
1671	289,44	71,32	3,46	447,02	399,280	307,050	680,2	431,088
1672	286,44	71,61	3,46	446,61	394,453	307,330	673,4	432,458
1673	284,14	71,44	3,41	446,16	387,686	307,396	667,0	433,451
1674	281,25	71,37	3,41	445,95	384,937	307,795	661,1	434,576
1675	278,94	71,40	3,36	445,70	384,947	307,918	655,4	435,331
1676	276,99	71,43	3,36	445,31	382,161	308,098	650,0	436,269
1677	275,14	71,07	3,31	444,90	400,290	308,138	644,9	436,993
1678	273,54	71,07	3,31	444,74	399,919	308,564	640,0	437,582
1679	270,77	71,01	3,31	444,21	399,563	308,536	635,1	438,166
1680	268,49	71,13	3,26	443,91	395,163	308,748	630,6	438,686
1681	266,73	71,00	3,26	443,33	390,251	308,954	625,8	439,062
1682	264,82	70,90	3,26	443,08	380,493	309,416	621,0	439,405
1683	262,93	70,76	3,21	442,36	374,148	309,253	616,4	439,797
1684	261,03	70,79	3,21	442,24	373,415	309,633	611,8	440,092
1685	259,60	70,78	3,21	441,89	372,127	309,670	607,2	440,083
1686	257,88	70,88	3,16	441,28	370,816	310,084	602,7	440,318
1687	256,11	70,83	3,16	440,55	371,280	310,301	598,5	440,108
1688	254,63	70,96	3,16	439,97	370,138	310,573	594,5	440,430
1689	252,98	70,88	3,11	439,53	370,235	310,576	590,6	440,395
1690	251,74	70,98	3,11	439,16	370,272	310,694	586,8	440,230
1691	250,11	71,18	3,11	438,70	369,147	311,035	582,9	440,015
1692	248,84	71,10	3,06	438,25	369,000	310,907	578,8	440,023
1693	247,54	70,84	3,06	437,67	369,171	311,241	575,1	439,927
1694	246,69	71,09	3,06	437,29	369,212	311,678	571,8	439,972
1695	245,10	70,86	3,01	436,65	369,361	311,786	568,5	439,791
1696	243,93	70,59	3,01	436,05	369,219	311,953	565,4	439,588
1697	243,11	70,77	2,96	435,29	366,881	312,335	562,6	439,238
1698	242,27	70,74	2,96	434,80	366,488	312,550	559,9	438,927
1699	241,31	70,57	2,96	434,34	366,296	312,387	557,1	438,800
1700	240,22	70,77	2,91	433,64	365,939	312,602	554,7	438,639
1701	239,27	70,88	2,91	432,89	365,597	313,060	552,4	438,145
1702	238,69	70,84	2,91	432,41	365,703	313,165	550,1	437,941
1703	237,86	70,57	2,86	431,61	365,757	313,369	547,9	437,711
1704	236,76	70,67	2,86	431,17	365,907	313,398	545,7	437,342
1705	235,90	70,59	2,86	430,83	365,914	313,637	543,6	436,924
1706	235,50	70,85	2,86	430,31	365,847	313,737	541,6	436,728
1707	234,86	70,97	2,81	429,55	366,129	314,117	539,8	436,381
1708	234,03	71,00	2,81	429,06	367,018	314,366	538,2	435,796
1709	233,49	70,90	2,81	428,36	367,127	314,641	536,7	435,150

1710	232,99	70,77	2,76	428,08	367,532	314,880	535,2	434,799
1711	232,83	70,75	2,76	427,57	367,497	315,069	533,6	434,439
1712	232,12	70,58	2,71	426,84	367,649	315,145	532,2	433,796
1713	231,29	70,65	2,71	426,36	367,984	315,488	530,8	433,430
1714	231,25	70,92	2,71	426,12	367,770	315,691	529,6	432,808
1715	230,63	70,70	2,71	425,50	367,784	315,778	528,4	432,508
1716	229,71	70,91	2,66	425,03	367,649	316,079	526,9	432,041
1717	229,40	70,91	2,66	424,76	367,864	316,192	525,6	431,450
1718	229,26	70,72	2,66	424,20	369,372	316,522	524,9	431,065
1719	229,17	70,68	2,61	423,55	369,328	316,516	524,2	430,397
1720	228,63	70,56	2,61	423,32	369,362	316,416	523,2	430,144
1721	228,61	70,57	2,61	422,81	369,314	316,615	522,6	429,645
1722	228,52	70,66	2,56	422,15	370,704	316,987	521,8	429,188
1723	228,16	70,78	2,56	421,63	370,824	316,926	521,1	428,596
1724	228,04	70,69	2,56	421,32	370,718	317,164	520,4	427,980
1725	227,67	70,81	2,51	420,90	370,498	317,339	519,7	427,609
1726	227,36	70,63	2,51	420,41	370,602	317,316	519,0	427,095
1727	227,30	70,63	2,51	420,13	370,556	317,655	518,2	426,690
1728	226,73	70,68	2,46	419,56	370,639	317,497	517,3	426,400
1729	226,55	70,63	2,46	419,17	370,736	317,865	516,9	425,951
1730	226,50	70,66	2,46	418,69	370,976	317,845	516,7	425,542
1731	226,66	70,87	2,41	418,61	370,721	318,246	516,1	424,806
1732	226,44	70,89	2,41	417,86	370,655	318,438	515,6	424,428
1733	225,82	70,81	2,41	417,39	370,955	318,580	515,1	423,903
1734	225,71	70,80	2,36	417,07	371,529	318,711	514,6	423,261
1735	225,91	70,98	2,36	417,06	371,641	318,981	514,5	422,849
1736	225,96	70,83	2,36	416,53	371,660	318,956	514,4	422,220
1737	226,20	70,95	2,31	416,16	371,653	319,118	514,4	421,836
1738	225,23	70,81	2,31	416,00	371,582	319,222	514,2	421,300
1739	225,26	70,86	2,31	415,45	371,414	319,399	514,1	420,893
1740	225,46	70,80	2,31	415,15	371,246	319,408	513,9	420,285
1741	225,26	71,06	2,26	414,81	369,181	319,614	513,9	419,920
1742	225,37	71,21	2,26	414,50	367,436	319,649	513,7	419,509
1743	225,58	71,00	2,21	414,03	366,828	319,772	513,5	418,933
1744	224,95	71,23	2,21	413,84	366,638	320,127	513,1	418,507
1745	225,30	70,97	2,21	413,69	366,603	320,074	512,7	418,236
1746	225,29	70,77	2,16	413,12	366,830	320,126	512,2	417,690
1747	225,46	70,69	2,16	412,82	366,976	320,291	511,8	417,468
1748	225,01	70,39	2,16	412,65	367,057	320,355	511,5	417,119
1749	224,73	70,49	2,11	412,09	367,288	320,161	511,1	416,694
1750	225,07	70,50	2,11	412,20	367,170	320,416	510,8	416,401
1751	225,00	70,51	2,11	411,82	367,126	320,493	510,6	416,234
1752	225,02	70,50	2,11	411,68	366,983	320,660	510,3	415,816
1753	224,96	70,57	2,06	411,68	366,993	320,910	510,2	415,483
1754	225,24	70,69	2,06	410,97	377,217	320,969	510,4	415,077
1755	225,15	70,63	2,06	410,88	369,999	321,099	510,3	414,602
1756	224,90	70,73	2,01	410,96	366,920	321,195	510,4	414,317
1757	225,00	70,87	2,01	410,53	366,573	321,284	510,3	413,849
1758	224,81	70,78	1,96	410,64	366,668	321,270	510,2	413,349
1759	224,58	70,77	1,96	410,50	366,543	321,487	510,1	412,958
1760	224,23	70,95	1,96	410,35	366,414	321,733	510,0	412,333
1761	224,52	70,69	1,96	409,96	366,634	321,686	509,8	412,145
1762	224,01	70,82	1,91	410,11	366,585	322,040	509,4	411,917
1763	223,84	70,78	1,91	409,73	366,518	321,963	508,9	411,435
1764	224,04	70,94	1,91	409,65	366,981	322,280	508,5	411,234
1765	223,95	70,82	1,86	409,58	367,154	322,145	508,0	410,748
1766	223,38	70,72	1,86	409,40	367,282	322,199	507,7	410,480
1767	223,14	70,64	1,86	409,11	367,221	322,294	507,2	410,129
1768	222,92	70,60	1,81	409,00	367,473	322,314	506,6	409,824
1769	223,20	70,77	1,81	408,72	367,097	322,487	506,3	409,528
1770	222,65	70,58	1,81	408,79	367,013	322,295	505,6	409,112
1771	222,32	70,62	1,76	408,25	366,912	322,587	505,1	408,620
1772	222,14	70,72	1,76	408,30	368,143	322,564	504,6	408,399
1773	222,29	70,91	1,76	407,85	368,826	322,703	504,0	407,903
1774	222,13	70,88	1,71	407,45	368,780	322,467	503,5	407,685
1775	221,90	70,84	1,71	407,28	368,651	322,548	503,0	407,175
1776	221,97	70,98	1,71	406,96	368,432	322,523	502,5	406,750
1777	221,95	70,75	1,66	407,28	368,429	322,663	502,0	406,656
1778	221,37	70,85	1,66	406,66	368,098	322,513	501,6	406,066
1779	220,93	70,69	1,66	406,21	367,745	322,629	501,0	405,618
1780	220,85	70,77	1,61	405,95	367,681	322,695	500,6	405,232
1781	220,59	70,70	1,61	405,65	367,544	322,675	499,9	405,023
1782	220,47	70,86	1,61	405,33	367,385	322,739	499,2	404,501
1783	219,76	70,93	1,61	404,88	367,295	322,789	498,4	404,296
1784	219,78	70,83	1,56	404,74	367,062	322,748	497,9	403,751
1785	219,80	71,01	1,56	404,17	366,644	322,663	497,1	403,259
1786	219,74	70,97	1,56	403,81	367,284	322,601	496,5	402,842
1787	218,80	71,14	1,51	403,58	367,212	322,619	495,9	402,419
1788	218,87	71,34	1,51	403,07	366,271	322,489	495,3	401,932
1789	218,74	71,25	1,51	403,07	365,507	322,376	494,6	401,495
1790	218,49	71,20	1,51	402,36	365,180	322,404	493,9	401,064
1791	218,91	71,26	1,46	401,93	365,005	322,359	493,4	400,653
1792	219,13	71,30	1,46	402,03	364,612	322,412	492,8	400,198
1793	218,50	71,37	1,46	401,51	364,070	322,477	491,9	399,482
1794	217,91	71,44	1,41	400,78	363,734	322,446	491,0	399,120
1795	217,54	71,42	1,41	400,51	363,503	322,400	490,0	398,762
1796	216,74	71,24	1,41	400,12	363,190	322,275	489,0	398,284
1797	216,74	71,24	1,41	400,12	363,190	322,275	489,0	398,284
1798	216,74	71,24	1,41	400,12	363,190	322,275	489,0	398,284
1799	216,74	71,24	1,41	400,12	363,190	322,275	489,0	398,284
1800	216,74	71,24	1,41	400,12	363,190	322,275	489,0	398,284
1801	216,74	71,24	1,41	400,12	363,190	322,275	489,0	398,284
1802	215,30	71,49	1,31	396,81	361,799	321,907	482,7	395,525
1803	215,28	71,53	1,31	396,42	361,030	321,923	481,8	394,999
1804	215,36	71,79	1,31	396,13	360,677	321,798	481,0	394,653

1805	214,83	71,65	1,26	395,60	360,274	321,756	480,1	394,142
1806	214,29	71,12	1,26	395,22	360,040	321,588	479,4	393,865
1807	214,25	71,37	1,26	394,58	359,766	321,675	478,9	393,425
1808	213,77	71,44	1,26	393,98	359,533	321,425	478,2	392,924
1809	213,06	71,53	1,21	393,39	359,262	321,331	477,5	392,510
1810	212,60	71,60	1,21	392,83	358,927	321,244	476,7	392,127
1811	212,86	71,44	1,21	392,40	358,613	321,122	475,9	391,701
1812	212,78	71,50	1,21	392,32	357,722	320,892	475,5	391,159
1813	213,17	71,43	1,16	391,84	357,034	320,713	475,0	390,732
1814	212,68	71,48	1,16	390,97	356,456	320,559	474,4	390,266
1815	212,77	71,44	1,16	390,44	355,937	320,708	474,2	389,797
1816	212,88	71,42	1,11	389,83	355,610	320,686	474,0	389,567
1817	212,69	71,52	1,11	389,43	355,244	320,452	473,7	389,007
1818	212,80	71,38	1,11	388,78	354,876	320,197	473,6	388,455
1819	212,29	71,47	1,11	388,24	354,587	320,114	473,3	388,163
1820	212,37	71,33	1,06	387,92	354,248	320,053	473,0	387,588
1821	211,68	71,34	1,06	387,50	353,995	319,927	472,6	387,171
1822	211,40	71,41	1,06	387,11	353,467	319,663	472,1	386,615
1823	211,49	71,41	1,01	386,50	353,159	319,594	471,5	386,331
1824	211,15	71,32	1,01	386,03	352,905	319,399	470,9	385,893
1825	210,54	71,48	1,01	385,53	352,467	319,272	470,5	385,423
1826	210,47	71,42	1,01	385,21	352,145	318,924	469,6	384,868
1827	210,06	71,21	0,96	384,57	351,852	318,610	468,4	384,306
1828	209,48	71,26	0,96	384,22	351,554	318,444	467,0	383,952
1829	208,93	71,22	0,96	383,63	351,300	318,267	465,6	383,601
1830	208,30	71,36	0,96	383,22	350,924	317,905	464,0	383,040
1831	207,93	71,37	0,91	382,45	350,871	317,689	462,5	382,427
1832	207,13	71,36	0,91	382,00	350,440	317,618	461,0	381,836
1833	207,03	71,11	0,91	381,55	350,055	317,520	459,4	381,194
1834	206,50	71,24	0,88	381,14	349,617	317,377	458,0	380,716
1835	206,04	71,29	0,86	380,62	349,329	317,322	456,7	379,954
1836	205,54	71,25	0,86	380,21	348,872	317,148	455,4	379,391
1837	205,08	71,09	0,86	379,55	348,334	316,896	454,2	378,690
1838	204,79	71,19	0,86	379,14	347,864	316,736	453,0	377,829
1839	204,36	71,30	0,86	378,69	347,347	316,493	451,9	377,166
1840	204,36	71,26	0,81	378,19	346,773	316,110	450,8	376,313
1841	203,91	71,32	0,81	377,62	346,240	315,948	449,7	375,690
1842	203,82	71,28	0,81	377,24	345,713	315,460	448,6	374,752
1843	203,60	70,93	0,81	377,07	345,055	315,146	447,4	373,998
1844	203,22	70,86	0,76	376,15	344,569	314,829	446,3	373,399
1845	202,65	70,96	0,76	375,66	344,061	314,683	445,3	372,632
1846	202,37	70,87	0,76	375,34	343,530	314,306	444,3	371,829
1847	201,74	71,03	0,76	374,76	342,951	314,081	443,3	371,058
1848	201,53	71,01	0,71	374,17	342,369	313,818	442,5	370,236
1849	199,50	72,21	0,71	349,95	433,858	294,651	91,5	356,606
1850	199,46	72,26	0,71	349,96	433,464	294,241	91,4	356,469
1851	199,80	72,37	0,71	349,16	433,551	293,739	91,4	356,409
1852	199,67	72,13	0,66	348,89	432,578	293,675	91,1	355,976
1853	199,09	72,18	0,66	348,45	431,897	293,280	91,1	355,759
1854	199,03	72,17	0,66	348,00	431,690	293,163	91,1	355,568
1855	198,82	72,05	0,61	348,04	431,762	293,018	91,1	355,347
1856	198,88	71,94	0,61	347,39	432,566	292,791	90,7	354,999
1857	199,19	71,86	0,61	346,68	432,098	292,490	90,7	354,682
1858	198,77	71,97	0,61	346,19	429,953	292,231	90,8	354,490
1859	198,75	71,75	0,56	345,71	430,808	292,093	90,8	354,117
1860	198,64	71,95	0,56	345,37	430,813	291,977	90,8	353,882
1861	198,49	71,87	0,56	344,99	430,734	291,992	90,8	353,730
1862	198,22	72,00	0,56	344,79	431,389	291,801	90,8	353,416
1863	197,99	71,89	0,56	344,27	430,611	291,686	90,8	353,119
1864	197,72	71,93	0,51	344,16	430,042	291,496	90,8	353,010
1865	197,89	71,75	0,51	343,87	430,708	291,338	90,7	352,559
1866	197,78	71,89	0,51	343,23	430,956	291,183	90,7	352,317
1867	197,64	72,08	0,51	343,00	431,574	291,043	90,7	352,001
1868	197,46	71,89	0,46	342,81	431,429	290,913	90,6	351,539
1869	197,18	71,84	0,46	342,07	431,106	290,736	90,6	351,172
1870	196,83	71,95	0,46	342,00	427,493	290,586	90,6	350,751
1871	196,21	72,03	0,46	341,56	428,976	290,235	90,5	350,388
1872	196,57	71,91	0,41	341,13	429,536	290,226	90,5	349,937
1873	196,33	71,86	0,41	340,57	430,305	290,138	90,5	349,515
1874	196,19	71,74	0,41	340,39	429,756	290,081	90,4	349,104
1875	195,98	72,01	0,41	339,96	429,578	289,818	90,3	348,553
1876	196,02	71,91	0,41	339,53	429,092	289,637	90,3	348,182
1877	196,34	71,92	0,36	339,37	421,487	289,378	90,3	347,818
1878	195,60	72,01	0,36	338,94	421,334	289,266	90,2	347,199
1879	195,50	71,86	0,36	338,42	422,476	289,117	90,2	346,896
1880	194,99	72,07	0,36	338,13	420,150	288,827	90,1	346,305
1881	195,00	71,88	0,31	337,89	419,510	288,671	90,0	345,821
1882	194,63	71,84	0,31	337,49	418,428	288,432	90,0	345,496
1883	194,39	71,83	0,31	337,32	417,833	288,156	89,9	345,001
1884	194,10	71,88	0,31	336,57	416,847	287,594	89,8	344,569
1885	194,09	71,74	0,31	336,13	416,597	287,090	89,7	344,140
1886	193,88	71,82	0,26	335,96	416,396	286,917	89,6	343,556
1887	193,99	71,99	0,26	335,35	415,816	286,623	89,5	343,070
1888	193,62	72,06	0,26	335,18	415,358	286,426	89,4	342,848
1889	193,19	71,97	0,26	334,71	414,840	286,494	89,4	342,405
1890	193,24	71,93	0,21	334,36	414,275	286,435	89,3	341,870
1891	192,85	71,71	0,21	334,09	413,783	286,221	89,2	341,402
1892	192,48	71,81	0,21	333,32	413,677	285,906	89,1	340,980
1893	192,19	72,02	0,21	333,06	413,628	285,757	89,0	340,563
1894	192,12	72,07	0,21	332,44	412,985	285,472	88,9	340,118
1895	191,71	71,91	0,16	331,79	412,653	285,164	88,8	339,343
1896	191,46	72,03	0,16	331,51	412,053	284,818	88,7	339,267
1897	191,25	71,87	0,16	330,86	410,889	284,549	88,6	338,735
1898	191,26	72,00	0,16	330,31	409,531	284,092	88,5	338,286
1899	191,11	72,11	0,16	329,70	407,943	283,736	88,4	337,943

1900	190,47	71,94	0,16	329,29	407,844	283,568	88,3	337,404
1901	190,25	71,94	0,11	328,90	407,682	283,150	88,2	337,130
1902	189,97	71,98	0,11	328,45	407,137	283,142	88,0	336,594
1903	189,84	72,03	0,11	328,05	406,594	283,138	87,8	336,127
1904	189,37	72,04	0,11	327,16	406,036	283,032	87,7	335,735
1905	189,39	71,92	0,06	326,99	405,568	282,873	87,6	335,197
1906	188,98	71,81	0,06	325,97	404,782	282,622	87,4	334,783
1907	188,47	71,93	0,06	326,03	403,834	282,208	88,1	334,421
1908	188,35	71,99	0,06	325,03	401,809	281,942	87,9	333,944
1909	188,18	71,83	0,06	324,54	400,285	281,522	87,8	333,472
1910	187,64	71,82	0,06	323,92	395,918	281,096	87,7	333,031
1911	187,55	71,85	0,00	323,27	401,312	280,608	87,7	332,707
1912	73,02	68,65	8,86	66,66	66,28	66,434	65,9	67,1715
1913	121,27	68,60	8,76	66,64	66,29	66,435	66,2	67,1921
1914	238,21	68,63	8,66	66,65	66,34	66,432	66,9	67,2353
1915	371,53	68,64	8,46	66,73	66,44	66,456	68,2	67,3971
1916	461,05	68,79	8,26	66,99	66,62	66,517	69,3	67,9424
1917	524,25	68,91	8,06	67,83	66,89	66,586	70,1	69,3348
1918	563,53	68,95	7,81	69,87	67,31	66,671	71,1	72,2513
1919	560,13	69,06	7,61	73,38	67,82	66,763	71,8	76,7346
1920	552,07	69,19	7,41	78,11	68,46	66,933	71,9	81,9820
1921	556,16	69,03	7,21	83,60	69,23	67,125	72,3	88,1166
1922	565,80	69,39	6,96	90,17	70,11	67,339	72,5	95,1780
1923	583,71	69,53	6,76	97,06	71,20	67,671	72,7	103,8178
1924	602,49	69,69	6,51	103,75	72,58	68,109	73,1	113,0586
1925	607,14	69,66	6,31	110,17	74,13	68,616	73,3	121,7815
1926	620,34	69,79	6,06	115,97	76,09	69,256	73,7	129,1554
1927	634,87	70,01	5,86	121,32	78,40	70,059	73,9	135,7872
1928	653,09	70,37	5,61	125,93	81,25	70,976	74,4	141,2998
1929	660,60	71,09	5,36	130,31	84,62	72,059	74,8	146,2979
1930	658,31	71,11	5,11	134,66	88,01	73,232	75,2	150,0441
1931	651,43	71,71	4,91	140,00	91,90	74,544	75,4	153,5253
1932	628,73	71,73	4,71	144,63	95,78	75,937	75,5	157,3989
1933	625,34	71,70	4,56	149,14	99,93	77,427	75,5	162,4847
1934	635,32	71,63	4,31	154,19	104,80	79,040	75,8	169,2972
1935	640,89	71,81	4,11	159,90	108,40	80,701	75,9	176,2834
1936	638,72	71,83	3,96	166,15	112,59	82,536	76,1	182,8417
1937	635,45	71,90	3,76	172,90	116,83	84,472	76,2	189,5735
1938	623,48	71,30	3,61	179,53	122,25	86,557	76,7	196,5204
1939	617,01	71,60	3,46	186,77	132,32	88,691	76,5	203,4812
1940	617,06	71,75	3,31	194,18	138,93	90,981	76,4	210,5205
1941	615,29	71,35	3,11	201,58	171,05	93,346	76,4	217,8260
1942	610,55	71,41	2,96	209,15	192,14	95,923	76,5	225,0052
1943	600,62	71,23	2,86	216,83	201,79	98,618	76,7	232,1754
1944	592,50	71,76	2,91	224,47	209,49	101,581	76,8	239,0248
1945	524,66	71,77	20,12	232,27	217,34	104,712	76,0	246,5327
1946	533,95	71,73	20,02	239,11	225,93	107,784	76,1	253,2274
1947	582,00	71,41	19,82	245,68	234,16	110,991	76,1	259,4071
1948	597,62	71,43	19,67	251,84	242,03	114,288	76,5	265,3001
1949	596,49	71,45	19,48	259,42	238,19	118,431	75,8	271,8221
1950	585,98	71,16	19,37	266,72	230,59	124,311	75,6	278,8587
1951	579,54	71,67	19,17	272,54	225,10	128,252	75,5	284,9539
1952	579,98	71,95	19,02	277,59	220,75	131,206	75,6	290,1755
1953	565,65	71,81	18,87	281,86	216,76	133,723	75,4	294,4745
1954	561,36	71,96	18,77	285,53	213,32	135,857	75,2	298,0029
1955	560,62	71,98	18,62	288,54	210,08	137,760	75,2	300,7652
1956	544,83	71,72	18,42	291,05	191,39	139,442	75,2	302,9419
1957	534,45	71,69	18,32	293,07	173,11	140,940	75,0	304,7251
1958	574,62	71,49	18,07	294,73	169,76	142,375	75,0	306,1682
1959	648,96	71,71	17,82	296,17	166,81	143,657	75,3	307,3457
1960	677,48	71,57	17,57	297,48	164,75	145,094	75,6	308,2810
1961	690,13	71,54	17,27	298,98	163,03	146,450	75,9	309,1758
1962	694,02	71,93	17,02	300,68	160,23	147,801	76,2	310,3232
1963	692,46	71,83	16,77	302,89	159,47	149,153	76,4	311,7001
1964	692,61	72,09	16,47	305,76	159,00	150,445	76,6	313,3891
1965	691,88	72,09	16,27	309,27	158,30	151,734	76,7	315,5216
1966	690,61	71,91	16,02	313,39	158,00	152,975	76,7	317,9145
1967	688,79	72,54	15,82	318,01	157,69	154,240	76,8	320,6580
1968	688,56	72,51	15,57	323,12	157,79	155,443	77,0	323,6243
1969	688,39	72,61	15,32	328,57	157,85	156,637	77,0	326,8482
1970	686,84	72,28	15,12	334,37	158,09	157,775	77,3	330,2725
1971	690,65	72,57	14,87	340,40	158,65	159,027	77,14	333,8311
1972	690,96	72,54	14,62	346,59	158,60	160,267	77,21	337,5839
1973	691,47	72,73	14,42	352,91	158,635	161,458	77,29	341,3242
1974	677,81	72,19	14,21	359,34	159,450	162,694	77,36	345,1642
1975	665,34	72,43	14,01	365,76	158,888	163,894	77,32	349,1247
1976	661,44	72,32	13,82	372,09	159,838	165,092	77,38	353,0240
1977	655,01	72,19	13,62	378,33	160,122	166,375	77,33	356,8719
1978	645,80	72,53	13,47	384,34	160,781	167,467	77,23	360,6795
1979	639,10	72,30	13,27	390,13	161,959	168,746	77,29	364,4572
1980	633,08	72,40	13,06	395,66	163,089	169,934	77,02	368,1469
1981	629,67	72,40	12,91	401,01	163,751	170,969	77,00	371,7632
1982	628,16	72,32	12,71	406,08	164,400	172,127	76,97	375,4417
1983	625,27	72,51	12,56	410,90	165,145	173,274	76,93	379,0750
1984	620,25	72,37	12,36	415,51	165,800	174,392	77,11	382,5565
1985	618,26	72,39	12,21	419,95	166,910	175,510	77,22	386,0831
1986	617,05	72,12	12,01	424,13	167,865	176,658	77,00	389,5830
1987	616,37	72,32	11,81	428,15	168,274	177,735	76,78	392,8771
1988	616,26	72,32	11,66	432,03	169,557	178,906	76,80	396,2631
1989	614,55	72,62	11,46	435,78	170,856	180,007	76,70	399,7327
1990	614,12	72,30	11,31	439,41	170,574	181,266	76,75	403,1136
1991	613,68	72,33	11,11	442,92	170,794	182,351	76,72	406,4876
1992	614,12	72,41	10,96	446,34	171,270	183,508	76,73	409,8063
1993	614,69	72,44	10,81	449,71	172,170	184,659	76,86	413,2445
1994	613,44	72,25	10,61	452,99	172,777	185,952	77,15	416,7235

1995	613,42	72,46	10,46	456,26	174,602	187,139	76,99	419,9986
1996	613,43	72,51	10,26	459,43	175,186	188,172	76,95	423,2432
1997	613,39	72,43	10,11	462,53	176,155	189,444	77,03	426,6554
1998	611,74	72,73	9,91	465,57	176,264	190,630	77,02	429,9438
1999	612,10	72,48	9,76	468,58	176,695	191,818	77,06	433,3160
2000	609,26	72,60	9,61	471,57	177,371	192,953	77,07	436,5485
2001	609,02	72,47	9,46	474,48	177,487	194,165	76,94	439,7399
2002	608,54	72,36	9,26	477,35	178,668	195,325	76,92	442,9240
2003	607,19	72,58	9,11	480,12	180,042	196,671	76,92	446,1277
2004	606,12	72,76	8,96	482,83	183,858	197,893	76,98	449,3727
2005	603,72	72,60	8,81	485,48	186,204	199,117	77,01	452,4964
2006	602,94	72,18	8,66	488,13	188,569	200,419	76,99	455,5624
2007	599,65	72,32	8,51	490,78	192,678	201,767	77,05	458,7000
2008	598,27	72,35	8,36	493,37	198,405	203,062	77,03	461,7213
2009	597,73	72,48	8,16	495,97	200,250	204,405	76,98	464,6151
2010	595,64	72,49	8,06	498,52	202,730	205,710	76,92	467,5130
2011	595,19	72,62	7,91	501,00	209,424	207,128	76,91	470,3501
2012	597,34	72,40	7,76	503,49	213,381	208,424	76,95	473,0901
2013	597,77	72,58	7,61	505,95	215,407	209,796	76,94	475,9389
2014	600,99	72,72	7,46	508,32	221,294	211,165	76,86	478,6317
2015	602,29	72,61	7,31	510,78	217,042	212,469	76,99	481,2426
2016	605,03	72,70	7,16	513,10	218,169	213,752	76,91	483,7408
2017	607,23	72,80	7,01	515,42	220,693	215,163	77,16	486,2786
2018	608,47	72,60	6,86	517,63	229,141	216,566	77,07	488,5848
2019	608,87	72,52	6,71	519,89	230,962	217,964	77,14	491,0472
2020	604,57	72,70	6,61	522,06	235,434	219,382	77,17	493,4521
2021	598,50	72,85	6,50	524,25	236,699	220,835	77,16	495,9277
2022	594,07	72,54	6,36	526,44	247,502	222,227	77,02	498,2109
2023	592,25	72,29	6,21	528,59	250,684	223,699	77,15	500,5606
2024	588,85	72,55	6,11	530,59	248,657	225,161	77,02	502,7596
2025	587,49	72,55	6,01	532,45	246,798	226,589	77,02	504,8946
2026	587,30	72,50	5,86	534,24	246,642	228,036	77,04	506,8849
2027	583,92	72,52	5,76	535,96	234,526	229,459	76,97	508,8572
2028	583,71	72,48	5,66	537,52	232,949	230,795	76,90	510,7202
2029	582,18	72,39	5,53	538,97	234,862	232,317	76,94	512,4189
2030	579,03	72,35	5,41	540,37	270,188	233,888	76,96	514,0732
2031	576,31	72,57	5,31	541,63	274,132	235,281	76,96	515,7494
2032	572,91	72,36	5,21	542,79	275,804	236,631	76,81	517,2263
2033	570,06	72,45	5,11	543,85	277,412	238,132	76,72	518,6755
2034	567,22	72,54	5,01	544,91	279,020	239,633	76,63	520,1246
2035	564,38	72,62	4,91	545,97	280,627	241,135	76,54	521,5738
2036	561,54	72,71	4,81	547,03	282,235	242,636	76,45	523,0230
2037	558,69	72,79	4,71	548,09	283,843	244,137	76,37	524,4721
2038	555,85	72,88	4,61	549,14	285,451	245,639	76,28	525,9213
2039	553,01	72,96	4,51	550,20	287,058	247,140	76,19	527,3704
2040	550,16	73,05	4,41	551,26	288,666	248,641	76,10	528,8196
2041	547,32	73,14	4,31	552,32	290,274	250,143	76,01	530,2687
2042	544,48	73,22	4,31	553,38	291,881	251,644	75,92	531,7179
2043	541,64	73,31	4,31	554,44	293,489	253,145	75,83	533,1671
2044	538,79	73,39	4,31	555,49	295,097	254,647	75,74	534,6162
2045	535,95	73,48	4,20	556,55	296,705	256,148	75,65	536,0654
2046	505,47	71,54	4,26	545,22	312,802	257,933	76,51	526,3118
2047	497,09	71,76	4,01	542,95	326,518	262,297	75,43	523,4099
2048	403,22	72,06	21,17	543,07	345,871	265,703	74,29	522,5743
2049	410,78	72,01	21,02	543,27	360,341	269,412	73,77	522,9044
2050	456,89	71,73	20,82	543,49	373,930	273,583	73,65	523,5176
2051	517,44	71,49	20,52	542,53	385,998	277,686	73,73	523,0049
2052	526,94	71,76	20,32	540,90	397,118	281,548	73,92	519,8943
2053	539,82	71,32	20,12	538,36	407,028	286,199	74,14	516,4075
2054	563,80	71,56	19,92	534,97	415,339	290,619	74,38	512,5297
2055	590,17	71,77	19,67	532,54	422,389	294,775	74,46	508,5373
2056	598,65	71,95	19,47	529,68	428,483	298,672	74,71	504,3261
2057	610,57	72,25	19,22	527,99	433,735	302,249	74,83	499,8084
2058	623,35	71,93	18,97	524,33	437,785	305,902	75,04	495,5374
2059	628,26	71,95	18,77	522,42	441,196	309,145	75,22	491,1388
2060	630,74	72,41	18,52	519,58	443,987	312,468	75,28	486,7872
2061	617,30	72,46	18,32	517,17	446,368	315,677	75,54	483,2650
2062	580,92	72,77	18,12	515,53	448,235	318,648	75,64	479,4005
2063	514,74	72,39	17,92	514,51	449,496	321,438	75,67	476,7019
2064	464,68	72,08	17,82	513,11	450,691	323,799	75,26	473,8632
2065	433,93	72,15	17,67	512,42	451,572	326,016	75,17	471,2467
2066	410,82	72,39	17,57	511,23	452,288	328,182	75,20	469,0574
2067	391,42	71,95	17,47	509,77	452,771	330,346	75,10	466,8496
2068	373,62	71,89	17,37	507,62	453,107	332,126	74,86	464,3452
2069	358,50	71,85	17,27	506,18	453,260	333,482	74,80	462,0731
2070	347,76	71,64	17,17	504,51	453,283	335,403	74,67	459,6082
2071	340,39	71,75	17,07	502,90	453,171	336,972	74,08	457,0424
2072	333,44	71,60	17,02	500,83	452,996	338,365	73,99	454,3588
2073	314,35	71,65	16,92	498,77	452,574	339,321	73,71	451,7382
2074	300,65	71,39	16,82	496,70	452,237	340,522	73,52	448,7104
2075	290,56	71,36	16,72	494,61	451,721	341,154	73,28	446,0538
2076	282,27	71,04	16,62	491,84	451,109	341,836	73,16	443,3049
2077	435,60	71,28	16,47	488,59	450,315	342,110	73,26	439,5247
2078	403,54	71,42	16,31	485,75	449,621	342,468	73,65	436,6019
2079	390,12	71,19	16,21	483,16	448,773	342,258	73,56	433,0786
2080	386,69	71,49	16,06	480,35	447,866	342,561	73,90	430,2676
2081	389,04	71,63	15,96	478,17	446,876	342,527	73,60	427,2361
2082	390,90	71,33	15,82	475,29	445,940	342,667	73,82	424,2488
2083	393,41	71,62	15,71	473,45	444,898	342,638	73,62	421,4060
2084	395,40	71,61	15,57	471,46	443,889	342,865	73,73	418,9927
2085	398,55	71,66	15,43	469,83	442,798	342,729	73,83	416,4402
2086	402,12	71,65	15,31	468,01	441,724	342,785	73,70	414,0858
2087	404,35	71,77	15,16	466,59	440,640	342,589	73,73	411,7596
2088	404,73	71,75	15,06	464,99	439,561	342,318	73,86	409,7070
2089	405,95	71,83	14,91	463,96	438,512	341,887	74,00	407,6669

2090	409,23	71,45	14,81	462,94	437,474	341,507	74,06	405,5869
2091	411,10	71,54	14,67	461,79	436,395	341,103	73,87	403,8513
2092	413,94	71,66	14,51	460,76	435,473	340,648	74,20	402,2987
2093	417,35	71,88	14,41	459,92	434,574	340,007	74,09	400,9070
2094	418,18	71,93	14,26	459,13	433,585	339,196	73,91	399,4909
2095	420,63	72,01	14,11	458,39	432,749	338,508	74,01	398,1078
2096	421,16	72,34	13,96	458,03	431,908	338,209	74,01	396,9817
2097	421,33	71,87	13,81	457,02	431,159	337,414	74,05	395,9683
2098	421,87	71,98	13,71	456,83	430,333	336,999	74,03	395,0060
2099	422,41	72,08	13,56	456,86	429,589	336,228	74,12	393,9036
2100	421,77	71,92	13,41	456,17	428,883	335,373	74,12	393,1267
2101	421,47	72,10	13,26	455,75	428,226	334,811	74,07	392,5732
2102	420,37	72,15	13,16	455,63	427,561	334,359	74,14	391,8492
2103	419,33	72,25	13,01	455,37	426,914	334,198	74,26	391,4621
2104	417,61	72,36	12,91	455,37	426,350	333,628	74,27	390,8762
2105	415,85	72,47	12,76	455,21	425,873	332,940	74,13	390,3031
2106	414,33	72,49	12,66	455,41	425,404	332,049	74,27	390,1460
2107	412,78	72,35	12,51	455,29	424,902	331,698	74,14	389,8895
2108	410,19	72,27	12,41	455,46	424,446	331,283	74,10	389,5106
2109	408,34	72,26	12,31	455,11	424,028	330,669	74,19	389,3571
2110	407,81	72,38	12,16	455,58	423,594	329,847	74,16	389,1546
2111	406,82	72,13	12,06	455,78	423,329	329,315	74,35	389,0826
2112	405,78	72,11	11,91	456,08	422,932	328,392	74,42	389,0633
2113	404,56	72,03	11,81	455,42	422,662	327,582	74,58	388,7760
2114	404,02	71,98	11,71	455,87	422,309	326,964	74,59	388,7932
2115	403,76	71,82	11,56	455,63	421,919	326,162	74,63	388,8511
2116	403,25	72,11	11,46	455,72	421,750	325,694	74,51	388,8650
2117	403,16	72,04	11,36	455,22	421,523	325,249	74,52	388,8238
2118	403,34	72,12	11,21	454,68	421,263	324,950	74,78	388,9332
2119	404,04	72,41	11,11	455,18	421,046	324,653	74,94	388,8674
2120	404,33	72,40	11,01	454,81	420,838	324,005	74,96	388,9766
2121	403,10	72,21	10,91	454,90	420,586	323,137	75,1	389,0625
2122	402,02	72,37	10,76	454,60	420,442	322,106	75,1	389,0736
2123	403,30	72,39	10,66	454,70	420,208	321,614	75,0	389,0846
2124	403,32	72,29	10,56	454,87	420,047	321,044	75,2	389,2187
2125	403,61	72,04	10,46	455,13	419,984	320,435	75,2	389,1581
2126	404,15	72,29	10,36	455,74	419,951	319,771	75,0	389,4637
2127	404,24	72,25	10,26	455,45	419,974	319,609	75,3	389,6133
2128	403,46	72,23	10,16	455,84	419,921	319,063	75,2	389,8181
2129	403,57	72,45	10,01	456,15	419,869	318,701	75,1	389,9826
2130	402,36	72,59	9,91	456,22	420,042	318,101	75,2	390,1572
2131	402,14	72,64	9,81	456,57	420,129	317,690	75,2	390,3271
2132	400,83	72,36	9,71	456,86	420,322	317,319	75,3	390,4771
2133	399,43	72,51	9,61	457,41	420,523	316,672	75,3	390,7911
2134	399,47	72,56	9,51	457,81	420,732	316,238	75,3	391,0237
2135	399,01	72,23	9,41	458,32	421,025	315,697	75,4	391,1974
2136	397,97	72,13	9,31	458,33	421,265	315,455	75,4	391,4787
2137	399,72	72,44	9,21	458,79	421,593	315,191	75,4	391,7057
2138	399,91	72,51	9,11	458,79	421,941	314,561	75,4	391,8930
2139	400,16	72,66	9,01	459,30	422,285	314,316	75,5	392,1651
2140	399,88	72,60	8,91	459,52	422,649	313,867	75,5	392,3626
2141	400,48	72,60	8,81	459,97	423,022	313,591	75,4	392,5743
2142	400,98	72,56	8,71	460,97	423,342	313,287	75,3	392,8126
2143	401,77	72,37	8,61	461,03	423,661	312,776	75,1	393,0316
2144	401,86	72,57	8,51	460,98	424,124	312,441	75,2	393,2684
2145	401,30	72,26	8,41	461,91	424,515	311,970	75,2	393,5515
2146	400,50	72,16	8,31	462,31	424,904	311,550	75,1	393,7325
2147	400,20	72,40	8,21	462,61	425,221	311,396	75,2	393,9500
2148	399,27	72,32	8,11	462,89	425,716	311,277	75,4	394,2587
2149	398,41	72,19	8,01	463,49	426,079	311,075	75,3	394,6133
2150	397,41	72,39	7,91	463,80	426,489	310,857	75,4	395,0187
2151	397,06	72,30	7,81	464,09	426,950	310,411	75,4	395,3507
2152	396,97	72,43	7,71	464,94	427,484	310,120	75,4	395,6219
2153	396,19	72,45	7,61	465,42	427,947	309,890	75,4	395,9368
2154	395,82	72,18	7,51	465,73	428,554	309,558	75,3	396,2301
2155	396,53	72,05	7,41	466,17	429,075	309,452	75,2	396,7412
2156	396,35	72,07	7,31	466,38	429,540	309,353	75,0	397,0541
2157	397,01	72,00	7,21	466,78	430,124	309,179	75,2	397,4101
2158	396,95	72,08	7,11	466,97	430,714	309,106	75,3	397,8940
2159	398,37	72,34	7,01	467,42	431,328	308,952	75,2	398,2328
2160	398,95	72,07	6,91	467,90	431,954	308,719	75,3	398,5217
2161	400,73	72,23	6,81	467,98	432,504	308,528	75,4	399,0074
2162	402,24	72,06	6,71	468,88	433,132	308,334	75,5	399,3816
2163	402,60	72,39	6,61	468,84	433,779	308,105	75,5	399,802
2164	403,36	72,28	6,51	469,48	434,427	307,975	75,6	400,266
2165	404,76	72,34	6,41	469,65	435,060	307,980	75,4	400,514
2166	404,58	72,36	6,31	470,08	435,770	307,868	75,5	401,163
2167	405,09	72,22	6,21	470,50	436,482	307,749	75,5	401,418
2168	406,84	72,35	6,11	470,76	437,193	307,413	75,6	402,052
2169	406,58	72,27	6,01	470,99	437,907	307,650	75,6	402,417
2170	405,84	72,36	5,91	471,54	438,662	307,591	75,5	402,655
2171	404,93	72,27	5,81	472,15	439,290	307,496	75,5	403,382
2172	404,66	72,49	5,71	472,41	440,040	307,656	75,8	403,833
2173	404,33	72,14	5,61	473,23	440,877	307,697	75,6	404,215
2174	403,90	72,05	5,56	473,39	441,687	307,388	75,6	404,807
2175	402,73	72,08	5,46	474,08	442,445	307,395	75,7	405,260
2176	400,39	72,24	5,36	474,45	443,343	307,276	75,7	405,824
2177	398,70	72,43	5,26	474,55	444,124	307,452	75,6	406,403
2178	393,18	72,48	5,21	474,95	444,942	307,555	75,6	406,731
2179	389,01	72,27	5,11	475,21	445,729	307,416	75,5	407,212
2180	386,59	72,30	5,06	475,43	446,554	307,511	75,5	407,736
2181	382,26	72,29	5,01	475,48	447,404	307,672	75,6	408,309
2182	378,13	72,50	4,91	475,49	448,337	307,779	75,5	408,900
2183	373,63	72,54	4,86	475,93	449,195	307,783	75,4	409,486
2184	369,16	72,33	4,81	475,56	450,123	307,555	75,3	410,193

2185	366,33	72,22	4,76	475,99	451,005	307,465	75,3	410,888
2186	363,13	72,43	4,71	476,12	451,907	307,766	75,2	411,683
2187	358,82	72,44	4,66	476,04	452,847	307,919	75,2	412,295
2188	355,48	72,59	4,61	476,82	453,842	307,842	75,3	413,038
2189	352,53	72,64	4,56	476,44	454,751	307,934	75,2	414,021
2190	349,40	72,69	4,51	477,00	455,648	308,186	75,2	414,808
2191	347,33	72,78	4,46	476,57	456,691	308,417	75,1	415,654
2192	346,33	72,74	4,41	476,92	457,655	308,397	75,1	416,414
2193	345,02	72,81	4,36	477,19	458,656	308,318	75,2	417,032
2194	343,71	72,85	4,31	477,70	459,604	307,727	75,1	418,094
2195	341,93	72,96	4,31	477,79	460,499	308,124	75,1	418,900
2196	339,45	72,63	4,26	478,01	461,453	308,797	75,2	419,805
2197	336,06	72,83	4,21	478,06	462,475	308,946	75,1	420,489
2198	333,17	72,87	4,16	478,60	463,301	309,478	75,1	421,032
2199	330,34	72,77	4,16	478,70	464,165	309,917	75,0	421,749
2200	326,88	72,87	4,11	479,07	465,000	310,016	75,0	422,484
2201	325,21	72,94	4,06	479,18	465,687	310,428	75,1	423,232
2202	323,71	73,05	4,06	479,25	466,469	310,700	75,0	423,692
2203	322,33	72,98	4,01	479,14	467,059	311,229	75,0	424,158
2204	320,95	72,92	4,01	479,03	467,650	311,757	74,9	424,624
2205	319,57	72,85	4,01	478,91	468,241	312,286	74,9	425,090
2206	318,19	72,79	4,01	478,80	468,832	312,815	74,8	425,556
2207	316,81	72,73	4,01	478,69	469,422	313,344	74,7	426,023
2208	315,42	72,66	4,01	478,57	470,013	313,872	74,7	426,489
2209	314,04	72,60	4,01	478,46	470,604	314,401	74,6	426,955
2210	312,66	72,54	4,01	478,35	471,195	314,930	74,6	427,421
2211	311,28	72,47	4,01	478,24	471,786	315,459	74,5	427,887
2212	309,90	72,41	4,01	478,12	472,376	315,987	74,5	428,354
2213	308,52	72,34	4,01	478,01	472,967	316,516	74,4	428,820
2214	307,13	72,28	4,01	477,90	473,558	317,045	74,3	429,286
2215	305,75	72,22	4,01	477,78	474,149	317,574	74,3	429,752
2216	304,37	72,15	4,01	477,67	474,740	318,102	74,2	430,218
2217	302,99	72,09	4,01	477,56	475,330	318,631	74,2	430,684
2218	301,61	72,03	4,01	477,44	475,921	319,160	74,1	431,151
2219	300,23	71,96	4,01	477,33	476,512	319,689	74,1	431,617
2220	298,85	71,90	4,01	477,22	477,103	320,217	74,0	432,083
2221	297,46	71,84	4,01	477,10	477,694	320,746	73,9	432,549
2222	296,08	71,77	4,01	476,99	478,284	321,275	73,9	433,015
2223	294,70	71,71	4,01	476,88	478,875	321,804	73,8	433,482
2224	293,32	71,64	4,01	476,76	479,466	322,332	73,8	433,948
2225	291,94	71,58	4,01	476,65	480,057	322,861	73,7	434,414
2226	290,56	71,52	4,01	476,54	480,647	323,390	73,6	434,880
2227	289,18	71,45	4,01	476,42	481,238	323,919	73,6	435,346
2228	287,79	71,39	4,01	476,31	481,829	324,447	73,5	435,813
2229	286,41	71,33	4,01	476,20	482,420	324,976	73,5	436,279
2230	285,03	71,26	4,01	476,08	483,011	325,505	73,4	436,745
2231	283,65	71,20	4,01	475,97	483,601	326,034	73,4	437,211
2232	282,27	71,13	4,01	475,86	484,192	326,562	73,3	437,677
2233	280,89	71,07	4,01	475,74	484,783	327,091	73,2	438,143
2234	279,51	71,01	4,01	475,63	485,374	327,620	73,2	438,610
2235	278,12	70,94	4,01	475,52	485,965	328,149	73,1	439,076
2236	276,74	70,88	4,01	475,40	486,555	328,677	73,1	439,542
2237	275,36	70,82	4,01	475,29	487,146	329,206	73,0	440,008
2238	273,98	70,75	4,01	475,18	487,737	329,735	73,0	440,474
2239	272,60	70,69	4,01	475,06	488,328	330,264	72,9	440,941
2240	271,22	70,62	4,01	474,95	488,919	330,792	72,8	441,407
2241	269,84	70,56	4,01	474,84	489,509	331,321	72,8	441,873
2242	268,45	70,50	4,01	474,72	490,100	331,850	72,7	442,339
2243	267,07	70,43	4,01	474,61	490,691	332,379	72,7	442,805
2244	265,69	70,37	4,01	474,50	491,282	332,907	72,6	443,271
2245	264,31	70,31	4,01	474,38	491,872	333,436	72,5	443,738
2246	262,93	70,24	4,01	474,27	492,463	333,965	72,5	444,204
2247	234,63	72,97	3,16	454,83	461,614	320,601	88,9	410,678
2248	234,70	72,92	3,16	453,49	461,368	320,613	88,3	410,136
2249	234,52	72,93	3,16	452,98	461,077	320,798	87,9	409,522
2250	233,59	72,72	3,16	452,28	460,867	320,481	87,2	408,785
2251	232,96	73,02	3,11	451,24	460,635	320,489	86,4	408,323
2252	233,12	73,10	3,11	450,29	460,460	320,496	86,1	407,775
2253	233,02	73,14	3,06	449,78	460,254	320,739	86,0	407,183
2254	232,54	73,17	3,06	449,07	460,100	320,850	86,0	406,633
2255	232,54	73,17	3,06	449,07	460,100	320,850	86,0	406,633
2256	232,54	73,17	3,06	449,07	460,100	320,850	86,0	406,633
2257	232,54	73,17	3,06	449,07	460,100	320,850	86,0	406,633
2258	232,54	73,17	3,06	449,07	460,100	320,850	86,0	406,633
2259	232,54	73,17	3,06	449,07	460,100	320,850	86,0	406,633
2260	232,54	73,17	3,06	449,07	460,100	320,850	86,0	406,633
2261	232,54	73,17	3,06	449,07	460,100	320,850	86,0	406,633
2262	232,54	73,17	3,06	449,07	460,100	320,850	86,0	406,633
2263	232,54	73,17	3,06	449,07	460,100	320,850	86,0	406,633
2264	232,54	73,17	3,06	449,07	460,100	320,850	86,0	406,633
2265	232,54	73,17	3,06	449,07	460,100	320,850	86,0	406,633
2266	232,54	73,17	3,06	449,07	460,100	320,850	86,0	406,633
2267	232,54	73,17	3,06	449,07	460,100	320,850	86,0	406,633
2268	232,54	73,17	3,06	449,07	460,100	320,850	86,0	406,633
2269	232,54	73,17	3,06	449,07	460,100	320,850	86,0	406,633
2270	232,54	73,17	3,06	449,07	460,100	320,850	86,0	406,633
2271	232,54	73,17	3,06	449,07	460,100	320,850	86,0	406,633
2272	232,54	73,17	3,06	449,07	460,100	320,850	86,0	406,633
2273	232,54	73,17	3,06	449,07	460,100	320,850	86,0	406,633
2274	232,54	73,17	3,06	449,07	460,100	320,850	86,0	406,633
2275	232,54	73,17	3,06	449,07	460,100	320,850	86,0	406,633
2276	232,54	73,17	3,06	449,07	460,100	320,850	86,0	406,633
2277	232,54	73,17	3,06	449,07	460,100	320,850	86,0	406,633
2278	232,54	73,17	3,06	449,07	460,100	320,850	86,0	406,633
2279	232,54	73,17	3,06	449,07	460,100	320,850	86,0	406,633



2280	230,68	72,84	2,81	438,51	458,109	320,521	84,9	399,399
2281	230,50	72,90	2,76	438,73	457,918	320,506	84,9	398,803
2282	229,91	72,93	2,76	437,25	457,740	320,587	84,8	398,658
2283	230,31	73,02	2,71	437,47	457,587	320,731	84,8	398,366
2284	230,05	72,86	2,71	436,16	457,355	320,692	84,7	398,139
2285	228,61	72,99	2,71	435,75	457,207	320,714	84,8	397,847
2286	227,37	72,89	2,71	435,18	457,054	320,758	84,6	397,508
2287	227,06	72,69	2,66	434,39	456,874	320,695	84,6	397,199
2288	226,63	72,84	2,66	434,09	456,770	320,664	84,5	396,976
2289	226,20	72,26	2,66	433,48	456,609	320,368	84,2	396,659
2290	225,61	72,46	2,61	432,66	456,511	320,057	84,1	396,290
2291	224,50	72,33	2,61	431,96	456,427	320,134	84,1	396,148
2292	224,22	72,48	2,61	431,59	456,293	320,182	84,0	395,690
2293	223,53	72,44	2,56	431,04	456,187	319,979	83,9	395,258
2294	223,25	72,10	2,56	429,91	456,139	319,278	83,7	395,003
2295	222,61	71,96	2,56	429,28	456,058	318,589	83,6	394,626
2296	222,46	71,93	2,56	428,65	455,995	318,949	83,6	394,220
2297	222,10	72,11	2,51	427,90	455,883	319,187	83,5	393,686
2298	221,56	72,11	2,51	427,14	455,782	319,332	83,5	393,324
2299	221,58	72,26	2,51	426,36	455,715	319,499	83,5	392,921
2300	221,33	72,10	2,51	426,29	455,658	319,365	82,6	392,367
2301	221,39	71,86	2,46	425,51	455,487	319,313	82,6	391,884
2302	220,24	72,08	2,46	424,05	455,381	319,420	82,5	391,550
2303	220,53	72,19	2,46	423,37	455,288	319,336	82,5	391,048
2304	220,45	72,33	2,41	422,59	455,210	319,334	82,5	390,503
2305	220,09	72,36	2,41	421,81	455,110	319,242	82,5	389,975
2306	219,62	72,42	2,41	421,00	454,983	319,156	82,5	389,494
2307	219,50	72,45	2,41	420,39	454,888	319,179	82,5	388,871
2308	219,38	72,43	2,36	419,66	454,772	319,063	82,4	388,412
2309	219,25	72,34	2,36	418,78	454,650	318,997	82,4	387,917
2310	219,11	71,96	2,36	417,98	454,531	318,865	82,5	387,356
2311	218,91	72,35	2,31	417,56	454,409	318,747	82,4	386,775
2312	218,91	72,47	2,31	416,99	454,264	318,566	82,4	386,316
2313	218,42	72,45	2,31	415,71	454,103	318,457	82,4	385,839
2314	218,15	72,46	2,26	415,33	453,987	318,325	82,4	385,348
2315	217,78	72,48	2,26	414,51	453,804	318,260	82,4	384,832
2316	217,38	72,48	2,26	413,64	453,697	318,172	82,4	384,277
2317	217,40	72,59	2,26	413,05	453,530	317,918	82,3	383,857
2318	217,67	72,41	2,21	412,57	453,423	317,765	82,3	383,403
2319	216,92	72,47	2,21	411,80	453,237	317,651	82,2	382,868
2320	216,55	72,40	2,21	411,08	453,099	317,618	82,3	382,420
2321	216,27	72,55	2,16	410,43	452,956	317,501	82,2	382,024
2322	216,01	72,46	2,16	409,77	452,763	317,401	82,2	381,604
2323	215,81	72,52	2,16	409,37	452,617	317,248	82,2	381,144
2324	215,49	72,10	2,16	408,65	452,363	316,975	82,2	380,813
2325	215,48	72,18	2,11	407,97	452,159	316,685	82,2	380,230
2326	215,26	72,27	2,11	407,46	451,946	316,600	82,2	379,908
2327	215,56	72,06	2,11	406,77	451,675	316,525	82,1	379,262
2328	215,54	72,09	2,06	406,33	451,457	316,304	82,1	378,952
2329	215,33	72,06	2,06	405,76	451,221	316,087	82,2	378,589
2330	215,13	72,29	2,06	405,04	450,967	315,972	82,2	378,172
2331	214,81	71,97	2,06	404,50	450,751	315,899	82,1	377,689
2332	214,43	72,33	2,01	403,64	450,420	315,494	82,1	377,451
2333	214,56	72,30	2,01	403,11	450,215	315,192	82,1	377,144
2334	213,88	72,28	2,01	402,96	449,961	314,734	82,1	376,643
2335	213,79	72,24	1,96	401,76	449,731	314,460	82,1	376,382
2336	213,57	72,14	1,96	401,75	449,561	314,159	82,1	376,028
2337	212,87	72,11	1,96	400,54	449,349	313,987	82,0	375,747
2338	212,93	72,07	1,96	399,94	449,138	313,527	82,0	375,327
2339	212,85	72,19	1,91	399,39	449,036	313,069	82,0	374,971
2340	212,31	72,19	1,91	398,62	448,873	312,812	81,9	374,737
2341	212,61	72,04	1,91	398,04	447,153	312,591	81,9	374,303
2342	212,19	72,25	1,86	397,29	447,061	312,362	81,9	373,952
2343	211,54	72,30	1,86	397,00	446,936	312,292	81,9	373,928
2344	211,66	72,29	1,86	395,98	446,888	312,263	81,9	373,558
2345	211,47	72,25	1,81	395,23	446,599	312,217	81,8	372,962
2346	212,06	72,26	1,81	394,50	446,545	312,004	81,8	372,612
2347	211,17	72,29	1,81	393,96	446,476	311,679	81,8	372,248
2348	211,38	72,19	1,81	393,76	446,462	311,408	81,8	371,983
2349	210,81	72,06	1,76	392,61	446,457	311,264	81,8	371,760
2350	210,62	72,04	1,76	391,79	446,244	311,048	81,8	371,211
2351	210,38	72,27	1,76	391,45	446,849	310,645	81,8	371,006
2352	210,27	72,25	1,76	391,00	448,316	310,751	81,8	370,581
2353	209,90	72,16	1,71	390,24	448,361	310,663	81,8	370,074
2354	209,58	72,13	1,71	389,58	447,086	310,471	81,8	369,780
2355	209,81	71,63	1,71	388,94	446,951	310,498	81,7	369,533
2356	209,45	72,18	1,66	388,50	446,982	310,663	81,8	369,167
2357	209,58	72,03	1,66	388,02	447,050	310,695	81,7	368,642
2358	209,33	72,08	1,66	387,25	447,126	310,660	81,8	368,406
2359	208,98	72,18	1,66	386,93	447,223	310,301	81,7	368,221
2360	208,62	71,97	1,61	386,01	447,277	310,243	81,6	367,871
2361	208,71	72,16	1,61	385,24	448,186	309,983	81,6	367,637
2362	208,40	72,14	1,61	384,83	448,698	309,800	81,6	367,262
2363	207,79	72,02	1,61	384,30	447,593	309,703	81,6	366,902
2364	207,78	71,90	1,56	383,56	447,585	309,267	81,6	366,771
2365	207,59	72,04	1,56	382,82	447,488	309,155	81,5	366,696
2366	207,59	72,00	1,56	382,19	447,399	308,806	81,5	366,168
2367	207,59	72,24	1,51	381,75	448,277	308,490	81,5	366,080
2368	207,43	72,11	1,51	381,20	448,148	308,194	81,5	365,708
2369	207,52	72,05	1,51	380,53	447,951	308,310	81,5	365,552
2370	207,02	72,10	1,51	380,19	447,671	308,295	81,5	365,351
2371	206,93	72,00	1,46	379,50	447,382	308,174	81,5	364,982
2372	206,93	71,89	1,46	378,90	447,033	308,100	81,5	364,741
2373	206,71	71,84	1,46	378,65	446,701	307,955	81,6	364,500
2374	206,64	71,94	1,46	377,92	446,256	307,698	81,7	364,285

2375	206,82	72,02	1,41	377,17	445,800	307,223	81,8	364,146
2376	206,60	71,90	1,41	376,62	445,356	306,778	81,8	363,999
2377	206,29	72,06	1,41	376,04	444,535	306,500	81,8	363,850
2378	206,18	72,07	1,36	375,32	444,118	306,274	81,7	363,829
2379	206,09	72,06	1,36	374,79	443,675	305,809	81,8	363,638
2380	206,21	72,05	1,36	374,64	443,351	305,774	81,8	363,639
2381	205,96	72,07	1,36	373,79	443,012	305,659	81,8	363,511
2382	205,45	72,13	1,31	373,23	442,644	305,440	81,8	363,451
2383	205,20	72,04	1,31	372,84	442,209	305,212	81,9	363,388
2384	205,01	72,03	1,31	372,15	441,935	305,056	81,9	363,260
2385	204,90	71,97	1,31	371,88	442,012	304,896	81,9	363,178
2386	204,56	71,83	1,26	371,17	441,726	304,741	81,9	363,023
2387	204,74	71,89	1,26	370,93	441,475	304,467	81,9	362,967
2388	204,10	71,87	1,26	370,08	441,236	304,281	81,9	362,776
2389	203,88	71,85	1,26	369,77	441,079	304,126	82,0	362,882
2390	204,13	72,05	1,21	369,20	440,843	303,987	82,0	362,753
2391	204,15	71,95	1,21	368,78	440,634	303,773	82,3	362,629
2392	203,94	71,91	1,21	368,10	440,443	303,580	82,3	362,454
2393	204,09	71,99	1,16	367,47	440,236	303,209	82,3	362,417
2394	203,85	71,82	1,16	367,01	440,061	303,045	82,2	362,263
2395	203,78	71,95	1,16	366,32	439,877	302,923	82,2	362,144
2396	203,77	71,96	1,16	366,27	439,688	302,681	82,2	362,053
2397	203,79	72,01	1,11	365,32	439,485	302,438	82,1	361,937
2398	203,87	72,02	1,11	364,85	439,307	302,089	82,1	361,740
2399	203,98	72,14	1,11	364,63	439,231	301,846	82,1	361,767
2400	203,57	72,10	1,11	363,73	439,143	301,639	82,1	361,626
2401	203,39	72,10	1,06	363,39	439,100	301,385	82,0	361,488
2402	202,73	72,17	1,06	362,68	439,083	300,909	82,0	361,425
2403	202,67	72,17	1,06	362,40	439,100	300,609	81,9	361,549
2404	202,48	72,08	1,06	361,72	439,151	300,227	81,9	361,571
2405	202,46	72,03	1,01	361,42	439,178	299,988	81,9	361,460
2406	202,50	71,85	1,01	361,04	439,237	299,866	81,9	361,154
2407	202,25	72,00	1,01	360,42	439,099	299,618	81,8	361,110
2408	201,42	72,07	0,96	360,14	439,363	299,457	81,9	360,990
2409	201,69	71,99	0,96	359,34	439,403	299,303	81,8	360,891
2410	201,77	71,97	0,96	359,10	439,419	299,100	81,8	360,700
2411	201,38	71,93	0,96	358,49	439,426	298,931	81,8	360,515
2412	201,57	72,22	0,91	358,17	439,350	298,803	81,7	360,390
2413	201,32	72,04	0,91	357,37	439,235	298,526	81,7	360,200
2414	201,28	72,08	0,91	356,86	437,712	298,104	81,7	360,045
2415	201,04	72,22	0,91	356,46	437,740	297,839	81,7	360,043
2416	201,28	72,19	0,86	355,91	437,664	297,568	81,6	359,925
2417	200,76	72,30	0,86	355,46	437,538	297,288	81,6	359,641
2418	200,89	72,13	0,86	355,04	437,272	296,939	81,6	359,533
2419	200,52	72,03	0,86	354,72	437,118	296,670	81,5	359,123
2420	200,74	72,09	0,81	354,25	438,022	296,491	81,5	359,176
2421	200,53	71,97	0,81	353,62	437,672	296,336	111,8	358,989
2422	200,60	72,07	0,81	353,55	436,116	296,219	91,9	358,701
2423	200,34	72,26	0,81	352,99	437,063	296,017	91,8	358,538
2424	200,43	72,34	0,76	352,75	436,711	295,921	91,8	358,310
2425	200,14	72,34	0,76	352,12	436,002	295,746	91,7	358,005
2426	200,19	72,07	0,76	351,95	435,206	295,616	91,6	357,753
2427	200,03	71,97	0,76	351,31	434,608	295,394	91,5	357,532
2428	199,96	72,27	0,76	351,14	435,379	295,273	91,5	357,209
2429	200,10	72,11	0,71	350,60	435,084	294,984	91,5	357,011
2430	199,50	72,21	0,71	349,95	433,858	294,651	91,5	356,606
2431	199,46	72,26	0,71	349,96	433,464	294,241	91,4	356,469
2432	199,80	72,37	0,71	349,16	433,551	293,739	91,4	356,409
2433	199,67	72,13	0,66	348,89	432,578	293,675	91,1	355,976
2434	199,09	72,18	0,66	348,45	431,897	293,280	91,1	355,759
2435	199,03	72,17	0,66	348,00	431,690	293,163	91,1	355,568
2436	198,82	72,05	0,61	348,04	431,762	293,018	91,1	355,347
2437	198,88	71,94	0,61	347,39	432,566	292,791	90,7	354,999
2438	199,19	71,86	0,61	346,68	432,098	292,490	90,7	354,682
2439	198,77	71,97	0,61	346,19	429,953	292,231	90,8	354,490
2440	198,75	71,75	0,56	345,71	430,808	292,093	90,8	354,117
2441	198,64	71,95	0,56	345,37	430,813	291,977	90,8	353,882
2442	198,49	71,87	0,56	344,99	430,734	291,992	90,8	353,730
2443	198,22	72,00	0,56	344,79	431,389	291,801	90,8	353,416
2444	197,99	71,89	0,56	344,27	430,611	291,686	90,8	353,119
2445	197,72	71,93	0,51	344,16	430,042	291,496	90,8	353,010
2446	197,89	71,75	0,51	343,87	430,708	291,338	90,7	352,559
2447	197,78	71,89	0,51	343,23	430,956	291,183	90,7	352,317
2448	197,64	72,08	0,51	343,00	431,574	291,043	90,7	352,001
2449	197,46	71,89	0,46	342,81	431,429	290,913	90,6	351,539
2450	197,18	71,84	0,46	342,07	431,106	290,736	90,6	351,172
2451	196,83	71,95	0,46	342,00	427,493	290,586	90,6	350,751
2452	196,21	72,03	0,46	341,56	428,976	290,235	90,5	350,388
2453	196,57	71,91	0,41	341,13	429,536	290,226	90,5	349,937
2454	196,33	71,86	0,41	340,57	430,305	290,138	90,5	349,515
2455	196,19	71,74	0,41	340,39	429,756	290,081	90,4	349,104
2456	195,98	72,01	0,41	339,96	429,578	289,818	90,3	348,553
2457	196,02	71,91	0,41	339,53	429,092	289,637	90,3	348,182
2458	196,34	71,92	0,36	339,37	421,487	289,378	90,3	347,818
2459	195,60	72,01	0,36	338,94	421,334	289,266	90,2	347,199
2460	195,50	71,86	0,36	338,42	422,476	289,117	90,2	346,896
2461	194,99	72,07	0,36	338,13	420,150	288,827	90,1	346,305
2462	195,00	71,88	0,31	337,89	419,510	288,671	90,0	345,821
2463	194,63	71,84	0,31	337,49	418,428	288,432	90,0	345,496
2464	194,39	71,83	0,31	337,32	417,833	288,156	89,9	345,001
2465	194,10	71,88	0,31	336,57	416,847	287,594	89,8	344,569
2466	194,09	71,74	0,31	336,13	416,597	287,090	89,7	344,140
2467	193,88	71,82	0,26	335,96	416,396	286,917	89,6	343,556
2468	193,99	71,99	0,26	335,35	415,816	286,623	89,5	343,070
2469	193,62	72,06	0,26	335,18	415,358	286,426	89,4	342,848

2470	193,19	71,97	0,26	334,71	414,840	286,494	89,4	342,405
2471	193,24	71,93	0,21	334,36	414,275	286,435	89,3	341,870
2472	192,85	71,71	0,21	334,09	413,783	286,221	89,2	341,402
2473	192,48	71,81	0,21	333,32	413,677	285,906	89,1	340,980
2474	192,19	72,02	0,21	333,06	413,628	285,757	89,0	340,563
2475	192,12	72,07	0,21	332,44	412,985	285,472	88,9	340,118
2476	191,71	71,91	0,16	331,79	412,653	285,164	88,8	339,343
2477	191,46	72,03	0,16	331,51	412,053	284,818	88,7	339,267
2478	191,25	71,87	0,16	330,86	410,889	284,549	88,6	338,735
2479	191,26	72,00	0,16	330,31	409,531	284,092	88,5	338,286
2480	191,11	72,11	0,16	329,70	407,943	283,736	88,4	337,943
2481	190,47	71,94	0,16	329,29	407,844	283,568	88,3	337,404
2482	190,25	71,94	0,11	328,90	407,682	283,150	88,2	337,130
2483	189,97	71,98	0,11	328,45	407,137	283,142	88,0	336,594
2484	189,84	72,03	0,11	328,05	406,594	283,138	87,8	336,127
2485	189,37	72,04	0,11	327,16	406,036	283,032	87,7	335,735
2486	189,39	71,92	0,06	326,99	405,568	282,873	87,6	335,197
2487	188,98	71,81	0,06	325,97	404,782	282,622	87,4	334,783
2488	188,47	71,93	0,06	326,03	403,834	282,208	88,1	334,421
2489	188,35	71,99	0,06	325,03	401,809	281,942	87,9	333,944
2490	188,18	71,83	0,06	324,54	400,285	281,522	87,8	333,472
2491	187,64	71,82	0,06	323,92	395,918	281,096	87,7	333,031
2492	187,55	71,85	0,00	323,27	401,312	280,608	87,7	332,707
2493	73,67	67,53	8,71	91,62	80,61	89,500	64,8	87,1912
2494	162,74	67,37	8,56	91,33	80,45	89,279	65,2	87,0358
2495	623,10	67,59	8,16	90,90	80,29	88,837	66,7	86,8592
2496	674,22	67,87	7,81	90,80	80,28	88,490	68,5	86,9420
2497	632,99	67,93	7,56	92,39	80,42	88,191	68,6	87,9245
2498	614,21	67,51	7,31	95,94	80,66	87,925	69,5	90,2731
2499	608,96	68,00	7,11	101,03	81,00	87,672	70,7	93,9282
2500	612,08	68,05	6,86	107,28	81,51	87,510	71,4	98,4950
2501	627,80	68,72	6,61	113,91	82,17	87,405	72,2	103,4536
2502	635,86	68,96	6,41	120,02	83,05	87,494	72,6	108,5214
2503	640,54	69,35	6,16	125,08	84,05	87,597	73,1	114,0264
2504	645,30	69,80	5,96	129,45	85,19	87,836	73,8	119,1694
2505	651,11	70,14	5,71	133,50	86,55	88,175	74,3	123,5270
2506	656,80	70,61	5,51	137,25	88,12	88,636	74,7	128,1513
2507	659,92	71,20	5,31	140,96	89,86	89,165	74,9	132,4963
2508	651,08	71,24	5,11	144,42	91,83	89,858	75,0	136,2558
2509	657,32	71,22	4,86	147,76	93,91	90,554	75,1	140,4390
2510	652,42	71,26	4,66	151,70	96,13	91,370	75,5	144,5675
2511	662,94	71,32	4,46	156,29	98,33	92,252	75,9	149,5306
2512	657,40	71,16	4,26	162,86	100,64	93,230	76,5	155,0867
2513	651,28	70,81	4,06	169,74	102,84	94,248	76,6	162,1931
2514	651,79	71,65	3,82	177,30	104,96	95,432	76,8	170,2184
2515	649,06	71,68	3,61	185,22	107,33	96,722	76,7	177,8530
2516	642,13	71,63	3,46	193,26	109,94	98,117	76,9	185,7004
2517	635,30	71,67	3,26	201,29	112,57	99,657	76,9	193,8489
2518	635,82	71,56	3,11	209,66	116,40	101,256	77,2	202,1593
2519	632,21	71,61	2,96	218,33	122,57	103,011	77,3	210,3245
2520	628,91	71,48	2,78	226,47	131,69	104,963	77,4	218,6747
2521	571,28	71,89	21,72	235,51	191,32	107,388	74,2	227,4801
2522	601,85	71,89	19,87	243,91	198,83	109,493	73,8	235,9182
2523	653,67	71,53	19,62	251,78	206,89	111,907	73,9	244,1248
2524	704,38	71,98	19,37	259,23	214,94	114,597	74,0	251,7497
2525	725,63	71,85	19,12	270,14	211,29	118,573	74,3	260,8204
2526	719,44	71,61	18,87	279,79	207,18	123,652	74,3	269,7457
2527	709,55	71,69	18,62	288,72	155,65	127,227	74,3	278,1393
2528	695,45	71,59	18,42	297,43	147,43	130,179	74,4	285,8539
2529	689,96	72,09	18,22	305,89	145,71	132,655	74,4	292,7867
2530	681,02	72,32	17,97	313,99	144,55	134,875	74,4	298,9226
2531	667,83	71,52	17,77	321,77	144,08	136,993	74,5	304,3549
2532	661,97	71,71	17,57	329,23	143,98	138,973	74,2	309,1427
2533	657,22	72,00	17,37	336,43	143,83	140,795	74,1	313,4026
2534	648,14	72,16	17,22	343,34	143,88	142,533	74,2	317,1373
2535	643,70	72,34	17,02	349,88	143,59	144,138	74,1	320,4971
2536	639,25	72,34	16,82	356,12	143,28	145,658	74,0	323,6323
2537	637,94	72,20	16,62	362,11	143,36	147,118	73,9	326,5810
2538	631,68	72,37	16,47	367,87	143,49	148,514	73,9	329,2999
2539	617,70	72,19	16,27	373,30	143,83	149,866	73,8	331,9785
2540	607,97	72,26	16,12	378,43	144,04	151,195	73,6	334,5094
2541	606,87	72,53	15,92	383,25	144,27	152,420	73,5	336,9049
2542	606,70	72,47	15,77	387,68	144,55	153,633	73,5	339,3421
2543	607,58	72,46	15,57	391,72	144,90	154,815	73,5	341,6391
2544	605,12	72,56	15,36	395,45	145,16	155,920	73,4	344,0355
2545	600,51	72,18	15,22	398,82	145,49	157,086	73,4	346,2823
2546	598,00	71,62	15,07	401,82	145,64	158,113	73,4	348,4929
2547	596,89	71,69	14,87	404,76	146,28	159,255	73,4	350,6411
2548	596,99	71,86	14,67	407,55	146,59	160,309	73,4	352,5996
2549	597,71	72,17	14,56	410,32	146,74	161,224	73,4	354,4211
2550	600,22	72,03	14,36	413,07	146,85	162,103	73,4	356,0903
2551	607,36	72,05	14,16	415,90	147,07	163,017	73,4	357,7591
2552	615,43	72,11	13,97	418,68	147,42	164,022	73,4	359,2641
2553	621,88	72,10	13,81	421,50	147,80	164,899	73,5	360,7302
2554	630,00	71,94	13,62	424,40	148,11	165,834	73,6	362,3757
2555	638,29	72,43	13,41	427,26	148,43	166,726	73,8	363,8395
2556	642,24	72,59	13,21	430,19	148,70	167,657	73,9	365,4763
2557	642,98	72,64	13,01	433,22	149,20	168,684	74,1	366,9656
2558	642,72	72,39	12,81	436,16	149,81	169,713	74,1	368,6173
2559	639,46	72,54	12,66	439,18	150,35	170,681	74,2	370,1000
2560	638,37	72,41	12,46	442,28	150,66	171,509	74,3	371,6695
2561	637,11	72,47	12,31	445,43	151,54	172,506	74,5	373,3715
2562	640,18	72,10	12,11	448,57	151,92	173,297	74,7	375,1658
2563	643,07	72,36	11,91	451,76	152,36	174,245	74,8	377,1289
2564	648,26	72,28	11,76	454,90	152,94	175,221	74,9	379,3316

2565	653,23	72,16	11,56	458,11	153,53	176,149	74,9	381,6135
2566	653,83	72,27	11,36	461,31	154,16	177,103	75,1	383,9730
2567	653,18	72,22	11,16	464,47	154,79	178,113	75,1	386,5798
2568	653,34	72,15	11,01	467,65	155,33	179,091	75,12	389,3034
2569	655,53	72,25	10,81	470,77	156,23	180,130	75,33	392,1732
2570	659,93	72,47	10,61	473,82	156,943	181,110	75,49	395,0960
2571	663,91	72,38	10,41	476,89	157,499	182,189	75,41	398,1044
2572	666,49	72,51	10,26	479,84	158,442	183,165	75,54	401,0790
2573	669,27	72,34	10,06	482,80	159,167	184,264	75,62	404,1250
2574	672,78	72,09	9,86	485,69	160,334	185,254	75,64	407,2856
2575	676,44	72,29	9,71	488,45	161,314	186,345	75,76	410,3987
2576	681,23	72,57	9,51	491,17	162,345	187,462	75,73	413,6387
2577	685,81	72,52	9,31	493,81	163,315	188,634	75,77	416,7815
2578	689,13	72,64	9,11	496,39	164,048	189,709	75,77	420,0334
2579	692,50	72,63	8,96	499,00	165,115	190,774	76,03	423,3555
2580	690,46	72,55	8,76	501,53	166,237	191,830	75,90	426,6085
2581	689,32	72,67	8,56	504,10	167,515	193,070	75,92	430,0095
2582	683,54	72,29	8,41	506,69	168,975	194,270	76,06	433,3363
2583	679,39	72,64	8,21	509,34	170,831	195,595	76,35	436,7437
2584	674,10	72,75	8,06	511,97	171,882	196,809	76,27	440,1229
2585	668,88	72,79	7,86	514,64	173,111	198,177	76,24	443,6789
2586	661,78	72,84	7,71	517,32	175,480	199,490	76,10	447,2650
2587	654,45	72,69	7,56	520,07	177,523	200,986	75,97	450,7657
2588	645,81	72,24	7,41	522,74	179,439	202,420	76,03	454,3795
2589	640,20	72,73	7,26	525,40	181,585	203,907	75,91	457,9374
2590	632,03	72,75	7,16	528,07	184,326	205,472	75,76	461,6019
2591	626,74	72,45	7,01	530,64	190,456	207,033	75,84	465,1266
2592	624,72	72,46	6,86	533,12	189,575	208,494	75,64	468,3824
2593	619,96	72,41	6,76	535,55	192,923	210,103	75,58	471,6735
2594	616,54	72,72	6,66	537,85	198,323	211,522	75,52	474,9492
2595	614,73	72,50	6,56	539,97	193,236	213,115	75,54	478,1146
2596	611,63	72,17	6,41	541,94	192,922	214,624	75,47	481,1736
2597	607,84	72,42	6,31	543,73	197,257	216,179	75,52	483,9506
2598	604,60	72,43	6,21	545,28	198,095	217,874	75,43	486,5924
2599	603,34	71,94	6,11	546,69	202,096	219,528	75,44	488,9769
2600	598,88	71,84	6,01	547,95	199,702	220,932	75,27	491,3029
2601	597,49	72,59	5,91	549,11	199,223	222,430	75,19	493,2748
2602	592,68	72,67	5,81	550,22	203,134	223,870	75,15	495,3687
2603	588,81	72,62	5,71	551,22	257,677	225,530	75,24	497,1197
2604	580,76	72,02	5,61	552,04	271,218	227,095	75,00	499,0685
2605	572,81	72,18	5,51	552,85	272,890	228,852	74,86	500,8653
2606	568,62	72,23	5,46	553,53	276,137	230,685	74,92	502,4223
2607	561,46	72,34	5,36	554,21	278,470	232,082	74,85	503,9199
2608	556,08	71,86	5,31	554,84	280,770	233,726	74,83	505,4217
2609	549,04	72,25	5,21	555,40	283,306	235,573	74,76	506,6975
2610	545,56	72,12	5,16	555,90	285,539	237,092	74,63	508,0602
2611	539,96	72,20	5,11	556,36	287,730	238,833	74,54	509,1953
2612	535,78	72,16	5,01	556,76	290,020	240,576	74,56	510,1356
2613	531,34	72,10	4,96	557,08	291,003	242,039	74,38	510,9826
2614	528,28	72,01	4,91	557,40	278,828	243,560	74,20	511,7740
2615	524,27	71,94	4,86	557,50	274,110	245,345	74,11	512,3350
2616	520,62	72,17	4,76	557,65	277,262	247,095	74,11	512,9230
2617	516,90	71,85	4,71	557,67	274,846	248,628	73,93	513,3040
2618	513,37	71,80	4,66	557,68	272,676	250,215	74,02	513,5918
2619	510,81	71,94	4,61	557,58	273,563	251,891	73,96	513,7729
2620	507,49	71,78	4,56	557,42	274,787	253,660	74,09	513,9706
2621	504,82	71,93	4,51	557,24	276,407	255,162	73,97	514,0293
2622	502,45	71,71	4,46	556,90	277,896	256,903	73,92	514,1386
2623	499,99	71,95	4,41	556,55	281,911	258,512	73,86	514,1150
2624	496,67	71,97	4,31	556,17	284,434	260,340	74,01	514,1257
2625	490,37	71,96	4,26	555,93	319,111	263,468	73,95	513,9224
2626	497,10	72,11	4,26	548,11	348,018	270,654	73,97	508,0574
2627	495,70	71,82	4,21	544,63	329,114	275,934	74,03	504,3809
2628	492,08	72,22	4,16	542,20	382,745	280,536	74,02	501,5315
2629	486,56	72,30	4,11	539,29	397,861	285,282	73,81	499,2228
2630	482,29	71,44	4,06	537,75	411,801	290,024	72,41	497,2485
2631	477,76	70,74	4,01	535,31	423,485	294,738	72,25	495,8032
2632	473,51	71,39	4,01	533,56	435,119	299,412	72,54	494,5373
2633	468,33	69,43	3,96	531,85	445,115	303,745	71,57	493,3546
2634	406,91	70,11	21,77	532,51	450,341	308,327	71,42	494,4924
2635	490,29	70,41	21,57	531,63	434,104	312,460	71,82	493,8041
2636	564,46	71,12	21,47	530,03	429,613	316,363	71,89	493,5360
2637	555,02	71,19	21,27	527,77	374,838	320,381	72,49	492,2104
2638	568,13	71,64	21,07	525,21	358,167	324,085	72,95	490,2015
2639	607,97	71,53	20,82	523,05	356,490	327,169	73,37	487,4613
2640	627,28	71,86	20,57	519,71	357,457	330,576	73,59	484,6447
2641	634,45	71,91	20,37	516,04	358,178	333,721	73,95	481,4937
2642	644,75	72,10	20,12	512,97	359,050	336,567	74,00	478,3735
2643	659,58	72,14	19,87	510,27	360,198	339,239	74,23	475,1413
2644	670,19	72,65	19,57	507,76	360,949	341,750	74,47	471,7024
2645	680,96	72,48	19,32	505,08	361,003	343,985	74,89	468,6691
2646	687,87	72,32	19,07	503,22	361,021	346,085	75,33	465,6246
2647	676,20	72,35	18,82	501,59	360,679	348,021	75,22	462,6678
2648	650,75	72,43	18,62	499,88	359,453	349,793	75,35	460,3219
2649	600,85	72,37	18,37	499,30	358,166	351,329	75,86	458,5442
2650	578,61	72,44	18,17	498,88	356,784	352,866	75,70	456,5784
2651	565,06	72,88	18,02	498,64	356,724	354,134	75,54	454,7423
2652	557,00	72,64	17,82	499,20	357,481	355,368	75,50	453,3491
2653	550,58	72,66	17,67	499,12	358,618	356,317	75,46	451,7953
2654	546,98	72,72	17,42	499,53	368,849	357,164	75,41	450,2520
2655	543,62	72,36	17,27	499,75	375,118	357,997	75,48	448,3845
2656	541,96	72,65	17,07	500,35	375,450	358,798	75,38	447,1161
2657	540,12	72,73	16,92	500,64	384,196	359,459	75,44	445,5442
2658	538,32	73,02	16,72	501,17	386,337	359,894	75,44	443,9297
2659	536,93	73,19	16,52	501,14	383,150	360,358	75,48	442,5919

2660	537,40	72,80	16,37	501,77	379,508	360,729	75,42	441,0347
2661	537,80	73,36	16,17	502,03	371,428	360,936	75,48	439,5587
2662	537,83	72,86	15,96	502,95	368,615	360,962	75,67	438,2463
2663	537,19	73,01	15,82	503,09	371,540	360,973	75,76	436,9831
2664	537,22	72,49	15,61	503,91	376,954	361,013	75,78	435,7725
2665	533,61	72,87	15,47	504,45	377,968	360,906	75,84	434,8395
2666	531,64	72,82	15,31	505,11	377,208	359,584	75,98	433,5274
2667	528,09	72,55	15,12	506,80	368,343	358,889	75,75	432,3340
2668	526,89	73,02	14,96	507,18	361,452	358,698	75,86	431,1251
2669	524,92	72,99	14,81	507,78	360,154	358,076	76,02	430,3622
2670	522,29	73,35	14,61	508,61	360,667	358,191	75,96	429,3261
2671	520,62	73,60	14,46	509,77	357,570	357,774	75,91	428,4278
2672	516,93	73,58	14,31	510,74	355,556	357,550	75,96	427,3872
2673	513,98	73,10	14,16	511,38	354,325	357,264	75,90	426,5272
2674	511,39	72,84	13,96	511,95	354,512	357,118	75,88	425,6626
2675	509,01	73,35	13,81	512,93	355,975	356,705	75,93	425,0047
2676	507,57	73,33	13,66	513,93	354,753	356,133	76,00	424,2554
2677	506,97	73,42	13,51	515,37	352,500	355,767	75,96	423,6809
2678	505,61	73,12	13,36	515,82	351,612	355,275	75,96	422,9536
2679	505,19	73,38	13,21	516,68	352,582	354,522	76,00	422,4157
2680	504,04	73,23	13,06	517,79	352,257	354,502	75,92	421,8571
2681	503,18	73,46	12,91	518,35	351,832	353,666	75,95	421,2758
2682	502,56	73,14	12,76	519,37	351,965	353,510	75,82	420,7697
2683	502,20	73,31	12,61	520,34	351,838	353,035	75,86	420,2319
2684	501,38	72,98	12,46	521,25	351,242	352,858	76,03	419,6203
2685	501,25	72,92	12,31	521,76	350,905	352,168	75,94	419,2464
2686	500,15	73,24	12,16	522,93	350,496	351,768	75,90	418,8470
2687	499,68	73,01	12,01	523,47	349,674	351,649	76,07	418,5143
2688	498,67	72,89	11,86	524,79	352,057	351,484	75,91	418,3070
2689	496,21	73,17	11,71	525,11	351,998	350,996	76,11	418,1610
2690	494,98	73,43	11,61	525,94	353,576	350,442	76,06	417,9466
2691	494,68	73,21	11,46	526,61	353,927	349,849	76,11	417,8512
2692	492,64	72,86	11,31	527,99	355,033	349,702	76,08	417,7214
2693	490,54	73,09	11,16	528,43	355,346	349,362	76,21	417,4451
2694	489,93	73,05	11,06	529,22	357,330	349,296	76,10	417,2623
2695	490,00	73,35	10,91	529,93	357,289	348,492	76,33	417,2542
2696	486,85	73,25	10,76	530,69	357,740	347,732	76,28	417,3529
2697	484,26	72,83	10,66	531,49	359,563	347,418	76,10	417,2509
2698	481,20	73,51	10,51	532,63	360,641	347,255	76,05	417,2636
2699	479,50	72,97	10,41	534,11	362,866	346,961	76,12	417,2087
2700	478,83	73,07	10,31	534,91	360,192	346,353	76,17	417,0942
2701	477,72	72,91	10,16	535,19	359,257	345,656	76,20	417,2223
2702	476,68	73,12	10,06	535,99	358,559	345,221	76,20	417,2650
2703	477,49	73,10	9,96	536,79	357,703	345,468	76,16	417,5202
2704	477,43	72,73	9,81	537,66	357,493	345,097	76,17	417,4860
2705	476,11	72,89	9,71	538,16	357,032	345,181	76,21	417,5505
2706	475,20	72,95	9,56	539,11	356,292	344,873	76,30	417,7359
2707	475,39	72,97	9,46	539,76	356,456	344,334	76,2	418,0983
2708	477,29	72,72	9,31	540,47	356,532	344,334	76,3	418,3485
2709	481,84	72,71	9,21	541,32	356,417	344,042	76,3	418,6915
2710	486,02	72,85	9,06	542,00	356,119	343,877	76,3	418,9301
2711	489,57	72,87	8,91	542,39	356,307	343,808	76,3	419,4690
2712	491,29	72,99	8,76	543,02	356,565	343,648	76,4	420,0903
2713	492,34	72,91	8,61	544,24	356,869	343,297	76,4	420,7121
2714	492,37	73,01	8,46	544,42	358,946	343,501	76,4	421,0966
2715	490,47	72,96	8,31	545,74	360,061	343,241	76,4	422,0746
2716	488,21	72,83	8,21	545,96	362,234	343,195	76,3	423,0493
2717	485,96	72,90	8,06	547,27	374,866	343,134	76,4	423,9014
2718	483,22	73,13	7,96	547,35	383,230	343,137	76,3	425,0234
2719	480,60	72,72	7,81	548,11	392,044	343,046	76,3	426,2138
2720	478,27	72,99	7,71	548,78	387,909	342,917	76,3	427,4746
2721	476,60	73,08	7,56	549,85	391,606	342,766	76,3	428,7292
2722	474,91	72,98	7,46	550,52	407,653	342,248	76,3	430,1123
2723	472,42	73,03	7,36	550,80	417,195	342,591	76,3	431,5812
2724	469,81	73,14	7,21	551,42	432,674	342,448	76,3	433,1776
2725	467,94	72,94	7,11	551,83	471,250	342,764	76,3	434,6849
2726	466,11	72,93	7,01	552,33	472,428	342,585	76,2	436,2729
2727	464,58	72,99	6,91	552,91	473,567	342,591	76,3	438,0199
2728	463,53	72,75	6,81	553,14	474,725	342,934	76,2	439,6536
2729	459,76	73,04	6,71	554,00	475,980	343,104	76,2	441,2626
2730	458,51	72,63	6,56	554,18	477,218	343,301	76,2	443,0578
2731	456,62	72,86	6,51	554,20	478,441	343,352	76,3	444,5325
2732	454,90	72,33	6,41	554,66	479,646	343,499	76,2	446,2683
2733	452,71	72,71	6,31	554,78	480,954	343,172	76,3	447,9170
2734	450,58	72,93	6,21	554,69	482,249	343,268	76,4	449,6081
2735	449,53	72,83	6,11	554,63	483,461	343,370	76,2	451,1637
2736	448,78	72,63	6,01	554,41	484,660	343,374	76,3	452,9718
2737	446,70	72,69	5,91	554,64	486,033	343,303	76,2	454,4491
2738	445,76	72,98	5,86	553,95	487,361	343,517	76,1	456,2107
2739	444,74	73,09	5,76	554,26	488,580	343,296	76,1	457,6227
2740	443,66	73,02	5,66	553,44	488,127	343,380	76,1	459,4339
2741	443,07	73,30	5,56	553,05	487,737	343,539	75,9	461,0552
2742	443,81	73,12	5,46	552,85	488,725	343,838	75,9	462,5092
2743	440,39	73,18	5,41	552,59	482,637	343,714	76,0	464,0136
2744	436,80	73,02	5,31	552,52	494,010	343,677	75,9	465,6245
2745	433,77	72,76	5,26	552,36	492,662	343,481	75,9	467,2764
2746	430,83	72,70	5,16	551,54	489,560	344,011	75,9	468,8315
2747	428,57	72,75	5,11	551,73	494,359	343,914	75,7	470,4903
2748	426,02	72,92	5,01	551,12	494,014	344,256	75,8	472,2089
2749	423,43	73,04	4,96	550,97	499,998	344,632	75,6	473,953
2750	420,14	72,70	4,91	550,47	504,069	345,031	75,7	475,501
2751	415,66	72,51	4,86	550,32	502,112	345,153	75,7	477,526
2752	411,89	72,91	4,81	549,67	502,972	345,379	75,6	478,954
2753	409,10	72,90	4,71	548,87	506,337	345,396	75,6	480,481
2754	406,75	72,87	4,66	548,61	503,721	345,268	75,5	482,153

2755	405,64	72,78	4,61	547,56	497,898	345,094	75,6	483,518
2756	403,76	72,35	4,56	547,56	485,928	345,609	75,5	485,074
2757	401,96	72,62	4,51	546,35	475,966	345,731	75,7	486,414
2758	399,96	72,68	4,46	545,93	469,375	346,056	75,5	487,856
2759	398,26	72,65	4,41	545,17	466,368	346,473	75,5	489,275
2760	395,70	72,99	4,36	544,56	469,355	346,461	75,5	490,317
2761	393,16	72,74	4,31	543,58	470,427	347,309	75,3	491,658
2762	389,82	72,80	4,26	542,86	469,648	347,429	75,2	492,769
2763	388,53	73,03	4,21	541,81	467,626	348,003	75,2	493,986
2764	386,89	72,70	4,16	541,24	467,209	348,456	75,2	495,276
2765	383,99	72,62	4,11	540,56	467,741	348,706	75,1	496,301
2766	379,01	72,26	4,11	539,94	468,029	348,996	74,9	497,232
2767	374,21	72,71	4,06	538,45	462,388	349,142	74,9	498,283
2768	370,57	72,79	4,06	537,48	478,343	349,786	75,0	498,982
2769	366,32	72,88	4,01	536,89	481,673	349,999	74,8	499,907
2770	363,79	72,62	3,96	535,67	480,354	350,302	74,8	500,311
2771	361,27	72,93	3,96	534,98	475,007	350,292	74,7	500,872
2772	358,91	72,85	3,91	533,80	471,525	350,179	74,6	501,103
2773	357,41	72,74	3,86	533,14	470,870	350,850	74,5	501,243
2774	356,56	72,61	3,86	532,26	469,389	351,390	74,6	501,167
2775	354,98	72,77	3,81	531,52	469,196	351,941	74,6	501,062
2776	353,47	72,39	3,76	530,48	469,325	352,215	74,5	500,818
2777	352,03	72,63	3,76	528,95	468,627	352,816	74,5	500,183
2778	350,37	72,62	3,71	528,55	467,660	353,003	74,5	499,866
2779	348,52	72,32	3,71	527,64	467,151	353,629	74,4	499,184
2780	346,29	72,43	3,66	526,23	466,518	353,220	74,4	498,265
2781	345,62	72,64	3,66	525,60	464,581	353,625	74,3	497,724
2782	344,25	72,46	3,61	524,32	463,348	354,130	74,4	496,675
2783	343,02	72,40	3,61	523,78	462,204	354,402	74,3	495,960
2784	340,73	72,35	3,56	522,73	460,061	354,915	74,1	494,977
2785	339,03	71,69	3,56	521,84	458,911	354,755	74,2	494,042
2786	337,24	72,08	3,51	521,01	456,793	355,032	74,2	493,086
2787	335,96	72,47	3,51	520,04	453,955	355,160	74,1	492,267
2788	334,50	72,50	3,46	519,07	445,792	355,502	74,2	491,213
2789	333,24	72,30	3,46	517,76	448,323	356,017	74,1	490,104
2790	330,85	72,12	3,46	516,88	449,616	356,293	74,2	489,311
2791	327,68	72,08	3,41	515,88	450,442	356,146	73,9	488,017
2792	325,09	72,32	3,41	515,06	449,251	356,660	73,9	486,902
2793	323,25	71,77	3,36	514,02	450,294	357,197	73,8	485,856
2794	321,01	71,86	3,36	513,29	426,748	357,306	73,9	484,683
2795	319,27	72,15	3,31	512,48	419,992	357,813	73,8	483,519
2796	316,67	72,06	3,31	511,70	414,457	358,597	73,6	482,477
2797	315,09	72,20	3,31	510,57	409,623	358,879	73,8	481,222
2798	313,52	72,24	3,26	510,22	408,266	359,193	73,8	480,023
2799	311,80	72,31	3,26	509,29	402,898	359,536	73,7	478,891
2800	309,97	72,17	3,26	508,78	399,685	359,913	73,6	477,477
2801	308,56	71,90	3,21	507,98	398,360	360,139	73,5	476,344
2802	307,56	72,27	3,21	507,54	397,229	359,862	73,4	475,073
2803	306,10	72,30	3,16	506,36	396,247	360,224	73,4	473,810
2804	304,92	72,24	3,16	505,01	394,067	360,241	73,3	472,497
2805	303,89	72,07	3,16	504,04	393,309	360,268	73,3	471,271
2806	302,58	71,78	3,11	503,19	393,002	360,605	73,4	470,053
2807	301,06	72,16	3,11	501,74	392,172	360,876	73,4	468,870
2808	299,67	71,95	3,11	500,98	391,858	360,755	73,4	467,415
2809	298,80	72,09	3,06	499,94	391,433	361,085	73,2	466,199
2810	298,11	72,30	3,06	498,52	390,949	360,954	73,3	464,991
2811	297,20	72,28	3,06	497,50	390,711	361,115	73,3	463,822
2812	296,52	72,17	3,01	496,27	390,272	361,293	73,4	462,524
2813	294,92	71,93	3,01	495,46	390,031	361,511	73,3	461,071
2814	294,57	72,25	2,96	494,18	389,945	361,340	73,2	459,736
2815	294,39	72,15	2,96	492,74	389,767	360,879	73,2	458,558
2816	293,13	71,93	2,97	491,69	389,730	361,155	73,2	457,323
2817	292,81	72,12	2,91	490,56	389,805	361,389	73,2	456,257
2818	292,22	72,09	2,91	489,04	388,970	362,133	73,1	455,012
2819	291,36	71,91	2,91	488,06	388,949	361,959	73,0	453,897
2820	290,84	71,97	2,86	487,06	388,094	361,687	73,0	452,625
2821	289,94	72,06	2,86	485,57	387,321	361,954	73,0	451,611
2822	288,74	72,07	2,86	485,08	386,784	362,228	73,0	450,324
2823	287,88	72,11	2,81	483,64	386,279	362,419	73,0	449,143
2824	287,30	72,14	2,81	482,55	385,479	362,100	73,0	448,121
2825	287,00	72,08	2,76	481,29	384,742	362,411	72,9	446,919
2826	286,51	71,97	2,76	479,72	384,359	362,103	73,0	445,766
2827	286,25	72,10	2,76	479,14	384,263	361,446	73,1	444,707
2828	285,76	71,89	2,71	478,15	388,730	361,953	73,0	443,665
2829	285,13	71,86	2,71	476,93	388,441	361,730	72,9	442,683
2830	285,23	72,12	2,71	476,17	387,880	361,432	72,9	441,498
2831	284,42	71,98	2,66	475,32	387,486	361,592	72,8	440,460
2832	284,01	71,48	2,66	474,22	387,083	361,462	72,9	439,570
2833	283,87	72,07	2,66	473,23	386,651	360,983	73,0	438,656
2834	283,70	71,90	2,61	472,40	386,487	361,118	72,8	437,724
2835	282,96	71,94	2,61	471,37	386,188	361,064	73,0	436,680
2836	281,76	72,10	2,61	470,30	385,444	360,934	73,0	435,657
2837	281,82	71,91	2,56	469,89	384,955	360,692	72,7	434,830
2838	281,08	71,83	2,56	468,99	382,444	360,867	72,6	433,992
2839	280,66	71,82	2,51	467,63	381,031	360,461	72,8	432,975
2840	280,87	71,62	2,51	467,03	379,485	359,909	72,7	432,215
2841	280,54	71,69	2,51	466,13	377,928	359,887	72,7	431,277
2842	280,13	71,57	2,46	465,30	377,113	360,126	72,6	430,360
2843	279,70	71,68	2,46	464,41	376,579	359,933	72,7	429,668
2844	279,45	71,76	2,46	463,84	375,860	360,087	72,6	428,766
2845	279,33	71,87	2,41	462,82	375,394	360,339	72,6	428,058
2846	278,54	71,66	2,41	462,11	374,864	360,064	72,5	427,290
2847	278,64	71,72	2,41	461,51	374,329	359,977	72,6	426,364
2848	278,53	71,50	2,36	460,66	373,885	360,113	72,6	425,556
2849	278,02	71,32	2,36	459,80	373,370	359,824	72,4	424,922

2850	276,92	71,60	2,36	459,11	372,940	359,885	72,6	424,206
2851	276,79	71,68	2,31	458,14	372,535	359,829	72,5	423,518
2852	276,46	71,57	2,31	457,36	372,242	359,748	72,5	422,846
2853	276,12	71,71	2,31	456,57	371,962	359,266	72,5	422,168
2854	275,85	71,60	2,26	455,96	371,508	358,888	72,4	421,456
2855	276,08	71,63	2,26	455,37	371,198	358,901	72,5	420,715
2856	275,12	71,65	2,21	454,47	370,925	358,926	72,4	420,010
2857	274,75	71,69	2,21	453,67	370,724	358,347	72,5	419,410
2858	274,68	71,84	2,21	453,36	370,344	357,838	72,5	418,788
2859	274,65	71,93	2,16	452,65	370,259	358,267	72,4	418,232
2860	273,82	71,96	2,16	451,83	370,092	358,139	72,5	417,538
2861	273,48	71,88	2,16	451,23	369,968	357,811	72,5	416,912
2862	273,27	71,99	2,11	450,38	369,886	357,443	72,5	416,168
2863	272,65	71,84	2,11	449,92	369,716	357,082	72,5	415,531
2864	272,51	71,61	2,11	449,38	369,478	357,272	72,5	414,892
2865	271,93	71,81	2,06	448,80	369,357	357,440	72,3	414,210
2866	271,58	71,44	2,06	448,06	369,238	357,637	72,4	413,817
2867	271,43	71,56	2,06	447,71	369,165	357,305	72,4	413,243
2868	271,49	71,75	2,01	446,86	369,063	357,150	72,4	412,540
2869	271,39	71,72	2,01	446,14	368,919	356,617	72,4	411,879
2870	270,94	71,69	2,01	445,70	368,857	356,439	72,3	411,417
2871	270,92	71,78	1,96	445,02	368,666	355,972	72,3	410,856
2872	270,26	71,65	1,96	444,41	368,487	355,459	72,3	410,248
2873	270,59	71,76	1,96	443,92	368,383	355,406	72,3	409,843
2874	270,00	71,72	1,91	443,60	368,444	355,413	72,1	409,159
2875	269,11	71,62	1,91	442,84	368,292	355,627	72,2	408,761
2876	269,29	71,60	1,91	442,30	368,198	356,275	72,2	408,134
2877	269,00	71,61	1,86	441,68	368,148	356,148	72,2	407,558
2878	269,02	71,44	1,86	441,02	368,128	355,653	72,2	407,140
2879	268,80	71,53	1,86	440,26	367,963	355,240	72,2	406,526
2880	268,58	71,51	1,81	439,99	367,872	355,005	72,1	405,969
2881	268,97	71,68	1,81	439,18	367,822	354,916	72,2	405,571
2882	268,25	71,36	1,81	438,66	367,691	354,470	72,1	405,045
2883	268,25	71,65	1,76	438,15	367,513	354,394	72,2	404,457
2884	267,96	71,49	1,76	437,65	367,362	354,125	72,2	403,978
2885	268,19	71,59	1,76	437,07	367,173	354,060	72,2	403,543
2886	268,20	71,69	1,71	436,62	367,063	353,592	72,2	403,013
2887	267,65	71,63	1,71	436,08	367,043	353,351	72,2	402,558
2888	268,02	71,79	1,71	435,58	366,920	353,821	72,3	402,237
2889	267,90	71,69	1,66	435,14	366,809	353,634	72,2	401,738
2890	267,71	71,68	1,66	434,33	366,772	353,188	72,3	401,282
2891	267,89	71,57	1,61	433,67	366,844	353,401	72,3	400,831
2892	267,69	71,73	1,61	433,12	366,825	352,958	72,2	400,413
2893	267,45	71,73	1,61	432,61	367,007	353,294	72,3	399,994
2894	267,56	71,71	1,56	432,21	366,977	353,255	72,2	399,653
2895	267,95	71,49	1,56	431,75	367,039	353,421	72,0	399,308
2896	267,40	71,46	1,56	430,99	367,076	353,205	72,1	398,898
2897	267,47	71,57	1,51	430,71	367,105	353,007	72,1	398,533
2898	267,19	71,66	1,51	430,12	367,157	353,190	72,1	398,233
2899	267,09	71,60	1,51	429,53	367,201	353,221	72,2	397,966
2900	266,80	71,58	1,46	429,12	367,114	352,434	72,1	397,708
2901	266,43	71,26	1,46	428,72	367,108	352,200	72,1	397,374
2902	266,48	71,60	1,46	428,47	367,119	352,318	72,1	397,120
2903	266,31	71,42	1,41	427,85	366,992	352,253	72,0	396,919
2904	265,40	71,57	1,41	427,22	366,851	351,910	72,1	396,804
2905	265,52	71,62	1,41	426,50	366,745	351,041	72,1	396,546
2906	265,12	71,70	1,36	425,95	366,364	350,693	72,1	396,299
2907	264,72	71,55	1,36	425,42	366,048	351,011	72,1	396,037
2908	263,98	71,69	1,36	424,55	365,828	350,787	72,1	395,775
2909	263,52	71,56	1,36	424,10	365,475	350,592	72,2	395,391
2910	262,83	71,40	1,31	423,20	365,133	350,800	72,0	395,301
2911	262,53	71,63	1,31	422,58	364,800	350,660	72,0	394,856
2912	262,00	71,61	1,26	421,74	364,460	350,612	71,9	394,724
2913	261,76	71,63	1,26	420,67	364,089	350,674	72,0	394,356
2914	261,78	71,01	1,26	420,01	363,739	349,858	71,9	394,043
2915	261,52	71,33	1,26	419,13	363,473	349,235	71,9	393,755
2916	261,34	71,42	1,21	418,76	363,042	349,467	72,0	393,563
2917	260,85	71,49	1,21	417,73	362,610	349,266	71,9	393,282
2918	260,74	71,59	1,21	416,77	362,110	348,843	72,0	392,905
2919	260,55	71,57	1,16	415,84	361,636	348,893	72,0	392,704
2920	260,18	71,50	1,16	414,93	361,154	349,022	72,0	392,318
2921	260,19	71,55	1,16	414,19	360,669	349,148	72,0	392,048
2922	259,78	71,62	1,16	412,97	360,230	348,760	71,9	391,618
2923	259,49	71,59	1,11	412,22	359,824	348,428	72,0	391,253
2924	259,86	71,53	1,11	411,22	359,378	347,978	72,0	390,839
2925	259,94	71,72	1,11	410,17	358,945	347,818	72,0	390,549
2926	259,23	71,52	1,06	409,44	358,559	348,039	71,9	390,093
2927	258,57	71,72	1,06	408,55	357,984	347,658	72,0	389,691
2928	258,42	71,47	1,06	407,63	357,613	347,366	71,9	389,349
2929	258,53	71,36	1,01	407,34	357,151	347,435	72,1	389,018
2930	258,37	71,52	1,01	406,20	356,722	346,552	72,0	388,485
2931	258,16	71,50	1,01	406,01	356,397	346,540	71,9	388,196
2932	258,15	71,42	0,96	404,67	356,062	346,311	71,9	387,689
2933	257,98	71,37	0,96	403,89	355,705	345,853	71,7	387,394
2934	257,87	71,03	0,96	403,18	355,358	345,637	71,8	386,974
2935	257,11	71,26	0,96	402,33	355,383	345,707	71,6	386,566
2936	257,42	71,34	0,91	401,64	354,965	345,262	71,6	386,158
2937	257,13	71,32	0,91	401,09	354,637	344,900	71,6	385,727
2938	256,52	71,25	0,91	400,03	354,325	344,382	71,6	385,325
2939	256,45	71,31	0,86	399,56	354,081	344,147	71,6	385,004
2940	256,44	71,11	0,86	398,83	353,947	344,320	71,6	384,825
2941	256,08	71,31	0,86	398,22	353,919	344,540	71,7	384,421
2942	255,95	71,02	0,81	397,51	353,648	343,908	71,6	384,040
2943	255,77	71,24	0,81	396,50	353,426	343,770	71,6	383,506
2944	255,52	71,27	0,81	395,90	353,141	343,083	71,7	382,979

2945	255,55	71,29	0,76	395,30	352,941	342,774	71,7	382,736
2946	254,95	71,20	0,76	394,75	352,688	342,603	71,5	382,400
2947	255,50	71,23	0,76	393,95	352,478	342,270	71,6	382,093
2948	254,92	71,31	0,76	393,31	352,340	341,474	71,5	381,729
2949	254,52	71,40	0,71	392,91	352,051	341,152	71,5	381,436
2950	254,04	71,28	0,71	392,00	351,679	340,550	71,5	380,976
2951	254,14	71,42	0,71	391,48	351,293	340,607	71,6	380,558
2952	254,08	71,32	0,71	390,87	351,032	340,511	71,6	380,310
2953	253,56	71,34	0,66	390,02	350,679	339,795	71,6	379,910
2954	253,54	71,28	0,66	389,50	350,432	339,509	71,6	379,622
2955	253,28	71,29	0,66	388,97	350,127	339,482	71,5	379,127
2956	252,76	71,34	0,61	388,20	349,822	339,293	71,5	379,005
2957	252,08	71,38	0,61	387,37	349,493	338,448	71,5	378,507
2958	251,70	71,43	0,61	386,69	349,229	338,115	71,5	378,196
2959	251,27	71,44	0,61	386,02	348,968	337,561	71,5	377,660
2960	251,62	71,41	0,56	385,46	348,640	337,269	71,3	377,437
2961	250,90	71,18	0,56	384,73	348,402	337,106	71,4	377,091
2962	250,36	71,31	0,56	384,35	348,149	336,782	71,3	376,554
2963	250,22	71,38	0,51	383,54	347,859	336,404	71,1	376,296
2964	250,05	71,12	0,51	382,74	347,611	335,727	71,3	375,766
2965	249,77	71,06	0,51	382,23	347,424	335,138	71,3	375,418
2966	250,07	71,00	0,51	381,87	347,132	335,075	71,2	375,152
2967	249,48	71,03	0,46	380,83	346,908	334,812	71,3	374,605
2968	249,48	71,09	0,46	380,23	346,662	334,732	71,2	374,110
2969	249,22	71,03	0,46	379,58	346,428	334,416	71,3	373,816
2970	249,07	70,94	0,41	378,65	346,204	333,681	71,3	373,373
2971	249,34	71,06	0,41	378,08	345,984	333,609	71,2	372,920
2972	249,32	70,99	0,41	377,33	345,675	333,147	71,2	372,371
2973	249,08	71,03	0,41	376,72	345,378	332,909	71,2	372,016
2974	249,09	70,88	0,36	376,01	345,111	332,368	71,2	371,533
2975	248,73	70,94	0,36	375,26	344,835	332,183	71,2	371,113
2976	248,39	71,00	0,36	374,53	344,567	332,057	71,1	370,691
2977	247,98	70,92	0,31	373,99	344,314	331,944	71,1	370,165
2978	247,70	70,94	0,31	373,31	344,072	331,933	71,1	369,942
2979	247,64	70,89	0,31	372,94	343,745	331,362	71,1	369,550
2980	247,25	70,77	0,31	372,12	343,463	330,974	71,0	369,076
2981	246,71	70,84	0,26	371,36	343,238	330,959	71,1	368,642
2982	247,01	70,89	0,26	370,77	342,976	330,954	71,1	368,331
2983	246,44	70,82	0,26	369,99	342,756	330,749	70,9	367,925
2984	246,30	70,70	0,21	369,30	342,472	330,132	71,0	367,533
2985	246,18	70,80	0,21	368,70	342,229	329,309	71,1	367,214
2986	246,11	70,76	0,21	368,02	342,033	328,816	71,0	366,953
2987	245,85	70,89	0,21	367,33	341,785	328,281	71,0	366,574
2988	245,68	70,80	0,16	366,86	341,731	327,608	70,9	366,222
2989	245,91	70,75	0,16	366,35	341,660	327,549	70,9	365,939
2990	245,36	70,68	0,16	365,66	341,452	327,614	71,0	365,685
2991	245,25	70,57	0,13	365,00	341,281	327,610	70,9	365,445
2992	244,82	70,61	0,11	364,23	341,066	327,175	70,9	365,032
2993	244,45	70,60	0,11	363,49	340,891	326,150	71,0	364,752
2994	244,49	70,68	0,11	362,96	340,795	325,737	70,9	364,518
2995	244,67	70,61	0,06	362,40	340,670	325,762	70,9	364,320
2996	243,77	70,60	0,06	361,81	340,538	325,159	70,9	363,984
2997	242,87	70,60	0,06	361,09	340,461	325,238	70,9	363,814
2998	242,50	70,57	0,06	360,28	340,420	324,905	70,9	363,546
2999	241,38	70,57	0,06	359,86	340,390	324,544	70,8	363,303
3000	240,22	70,63	0,01	359,24	340,290	324,319	70,8	362,945



## APPENDIX 5: Participants

**Danick Power ing.**  
v-p operation  
**Services Polytests inc.**  
450.741.3636  
[www.polytests.com](http://www.polytests.com)

**Sébastien Boulais**  
Technicien  
**Services Polytests inc.**  
450.741.3636  
[www.polytests.com](http://www.polytests.com)

**Maxime Martin**  
Technicien  
**Services Polytests inc.**  
450.741.3636  
[www.polytests.com](http://www.polytests.com)

## APPENDIX 6: Drawings and specifications



ITEM NO.	PART NUMBER	DESCRIPTION	EPI3/QT.Y.
1	W350-0603	HOUSING, FIREBOX	1
2	W035-0287	BASE, FIREBOX	1
3	W010-2884	ASSEMBLY, FIREBOX TOP WELDMENT	1
4	W600-0575	RETAINER, OUTER SHELL (REAR)	2
5	W080-0209	BRACKET, 5/16-18 X 9/16T 2701	2
6	W485-0010	PIN, HINGE	2
7	W330-0006	BUSHING, HINGE 7/8X7/8X3/8	2
8	W215-0158	DEFLECTOR, BLOWER AIR	1
9	W080-1284	BRACKET, LOG RETAINER	2
10	W080-1161	BRACKET, CASTING MOUNT	4
11	W010-2797	ASSEMBLY, S/A CHAMBER (RS)	1
12	W010-2530	ASSEMBLY, S/A CHAMBER (LS)	1
13	W720-0191	TUBE, SECONDARY AIR #1	1
14	W720-0192	TUBE, SECONDARY AIR #2	1
15	W720-0194	TUBE, SECONDARY AIR #3	1
16	W720-0194	TUBE, SECONDARY AIR #4	1
17	W720-0165	TUBE, PILOT	1
18	W600-0141	RETAINER AIR TUBE 5 X NZ6	1
19	W450-0028	NET, BRASS 3/8-16 HEX	4
20	W485-0047	PIN, HAIRPIN/COTTER 0.093 X 2-1/2	4
21	W010-2858	ASSEMBLY, OUTER BASE	1
22	W350-0604	HOUSING, OUTER SHELL	1
23	W705-0264	TOP, OUTER SHELL	1
24	W1150-0061	CHANNEL, AIR (TOP)	2
25	W1190-0052	CONTROL, AIR INDICATOR	1
26	W010-2548	ASSEMBLY, AIR CONTROL	1
27	W311-0189	INSULATION, FIREBOX BASE	1
28	W390-0185	BRICK, FRONT EDGE	1
29	W390-0186	BRICK, FRONT	1
30	W390-0184	BRICK, BOTTOM (LS)	1
31	W390-0185	BRICK, BOTTOM (RS)	1
32	W390-0192	BRICK, RIGHT SIDE	1
33	W390-0191	BRICK, LEFT SIDE	1
34	W390-0190	BRICK, REAR	1
35	W016-0133	BAFFLE, FIREBOX	1
36	W135-0485	CASTING, FLUE COLLAR	1
37	W735-0011	WASHER, 1/4" FLAT BLACK ZINC PLATED	8
38	W460-0001	NUT, HEX 1/4"-20	2
39	W200-0411	COVER, AIR CONTROL	1
40	W650-0794	SHIELD, SMOKE SHELF	1
41	W650-0647	PLATE, LOG RETAINER	1
42	W715-0916	TRIM, LOG RETAINER	1
43	W080-0245	BRACKET, SHIPPING	3
44	W290-0215	GASKET, S/A CHAMBER	2
45	W600-0693	RETAINER, BRICK (FRONT)	2
46	W600-0694	RETAINER, BRICK (REAR)	2
47	W625-0003	SPEAKER, FLUE	1
48	W200-0356	COVER, BLOWER	1
49	W080-1307	BRACKET, CASTING MOUNT (LOWER)	2
50	W670-0135	SCREW, SHOULDER 1/4-11X1/2 HEX WASH	2
51	W670-0007	SCREW, 1/4-20X3/8 HEX, HD SS, MS	25
52	W670-0018	SCREW, 9-11X1/2 WILDRIIL 1/4 HD SS	45
53	W670-0006	SCREW, #8X1/2" TEKSPAN HEAD	3
54	W670-0060	SCREW, #8 X 1/2" TRUSS HD (QUAD)	2
55	W670-0175	SCREW, #8 X 1-1/2" FLAT HEAD WOOD PHILLIPS	6
56	W650-0783	SHIELD, HEAT (BLOWER)	1
57	W018-0145	BAFFLE, REAR AIR	2
58	W600-0638	PLATE, RATING	1
59	W385-1905	LABEL, EPI3 BLOWER OPERATION	1
60	W290-0229	GASKET, BLOWER VIBRATION DAMPER	1
61	W065-0016	BOLT 1/4"-20X1-1/2" RND HD CMBIROB(SLOT)	4
62	W270-0031	SCREW, LEVELING 5/16-18 X 1.5 THRS	2
63	W361-0182	INSULATION, BLOWER HOUSING	1
64	W270-0047	SCREW, 1/4-20X1/2 ROBERTSON & SLOT	4
65	W735-0049	WASHER, 1/4" ID 1-1/4" OD	1
66	W080-1265	BRACKET, PALLET	2
67	W455-0469	SUPPORT, CASTING CENTRE	1
68	W010-4218	ASSEMBLY, CAST FRONT TRADITIONAL	1
69	W670-0187	SCREW, CAP 1/4-20 1/2", GRADE 5 STEEL HEX HEAD	8
70	W670-0199	SCREW, CAP 1/4-20 3/4", GRADE 5 STEEL HEX HEAD	5
71	W670-0160	SCREW, 1/4-20 SET	1
72	W010-4219	ASSEMBLY, CAST DOOR	1
73	W080-1249	BRACKET, CASTING	1
74	W600-0641	RETAINER, CASTING	4
75	W1150-0714	CASTING, LS (TRADITIONAL)	1
76	W1150-0715	CASTING, RS (TRADITIONAL)	1
77	W1150-0713	CASTING, CENTER SECTION (TRADITIONAL)	1
78	W350-0930	HOUSING, S/A VERTICAL	2
79	W120-0100	CAP, S/A ENTRANCE	2
80	W010-2882	ASSEMBLY, BLOWER	1

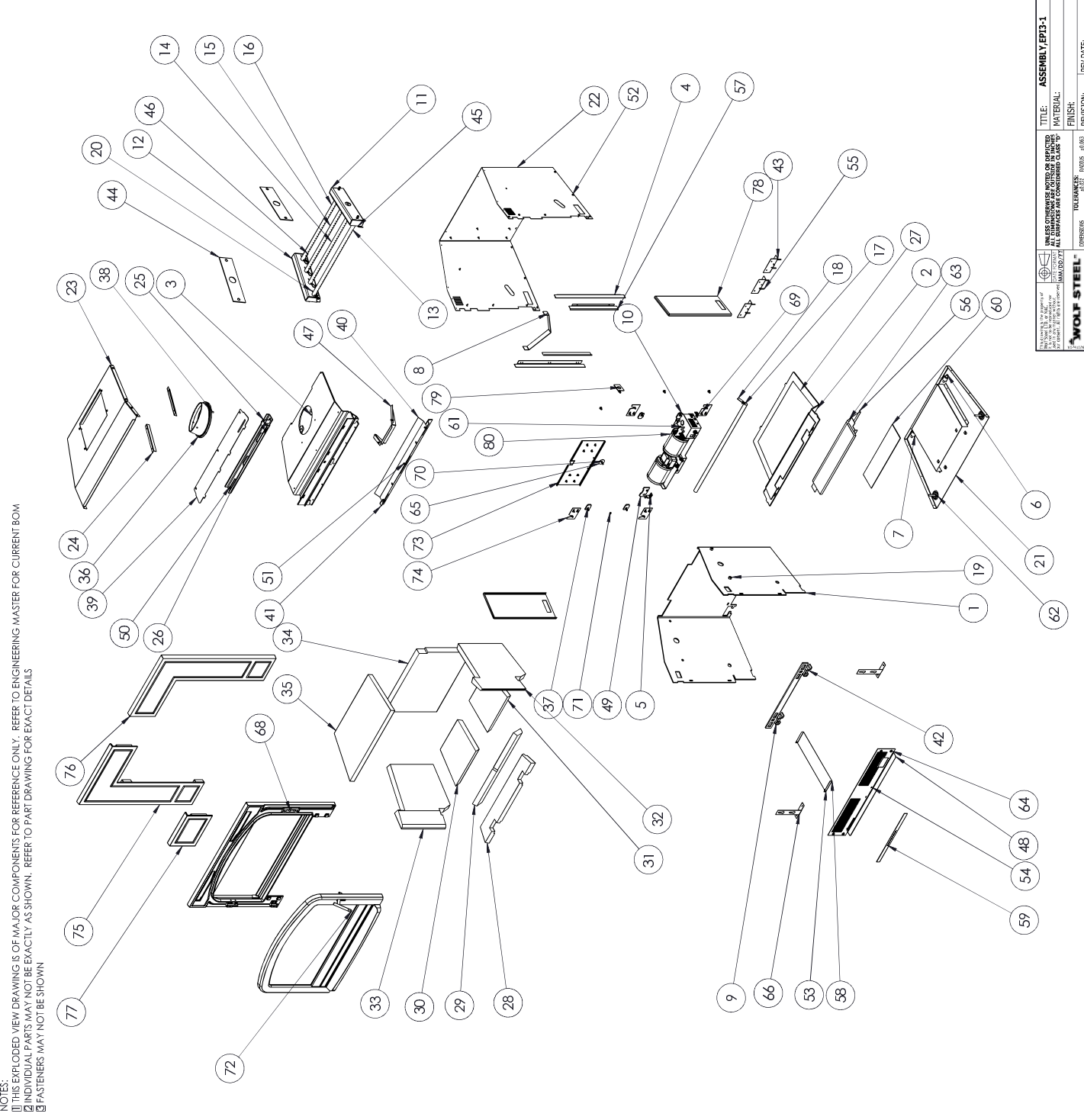

NOTES:  
 1) THIS EXPLODED VIEW DRAWING IS OF MAJOR COMPONENTS FOR REFERENCE ONLY. REFER TO ENGINEERING MASTER FOR CURRENT BOM.  
 2) INDIVIDUAL PARTS MAY NOT BE EXACTLY AS SHOWN. REFER TO PART DRAWING FOR EXACT DETAILS.  
 3) FASTENERS MAY NOT BE SHOWN.

**WOLF STEEL**  
 10000 Highway 100, Suite 100, Houston, TX 77036  
 Tel: 281-486-1000 Fax: 281-486-1001  
 Email: sales@wolfsteel.com  
 © 2010 Wolf Steel, Inc. All rights reserved.

**ASSEMBLY, EPI3-1**  
 TITLE: MATERIAL: FINISH: REVISION: REV. DATE:

PROJECT LEAD: P. HODGES  
 SCALE: 1:12 SHEET 1 OF 3  
 MODEL: EPI3-1 DRAWING: UNRELEASED  
 THICKNESS: 399.430 LBS  
 O.M.F.:  
 ISSUE DATE: UNRELEASED  
 CHECKED BY: UNRELEASED

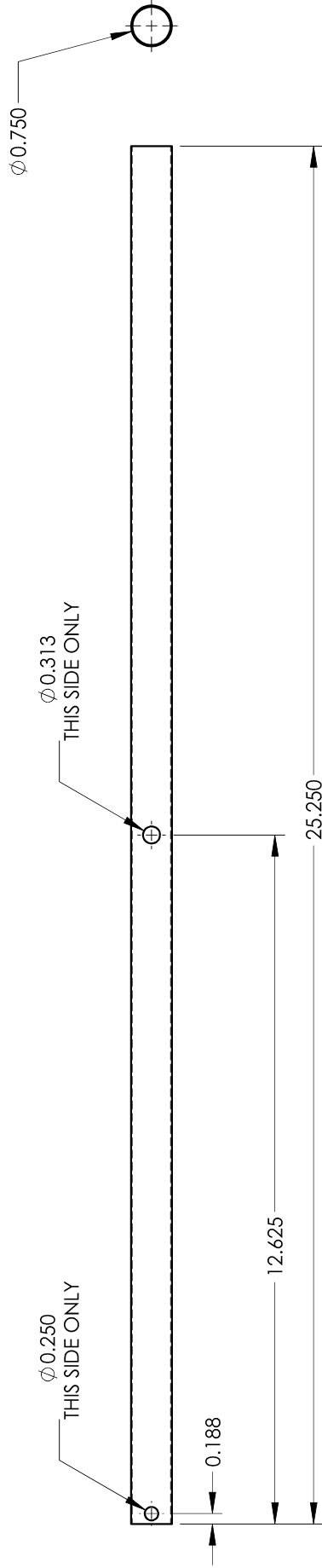

UNLESS OTHERWISE NOTED OR DEPICTED  
 ALL DIMENSIONS ARE OUTSIDE IN INCHES  
 UNLESS OTHERWISE SPECIFIED  
 WHERE APPLICABLE, FLAT IS SHOWN FINISHED SIDE UP

TOLERANCES:  
 FORMED PARTS ±0.031"  
 BEVELLED PARTS ±0.063"  
 SURFACE DIMENSIONS ±.2°  
 ANGLES

This drawing is the property of Wolf Steel Ltd., or NAC. It is to be used only for the project and location specified hereon. All rights are reserved.

**WOLF STEEL**<sup>TM</sup>  
**NAC** Manufactured in Canada

01/09/12 AR

TITLE:	<b>TUBE, PILOT</b>	MODEL:	EP13	DRAWING:	<b>W720-0165</b>
MATERIAL:	18 GA 430 ST. ST. - ZB FINISH	THICKNESS:	0.048	DRAWN BY:	<b>A.RIGDEN</b>
FINISH:		SCALE:	1:3	MM/DD/YYYY:	<b>6/13/2012</b>
REVISION:	-			SHEET 1 OF 1	CHECKED BY: <b>R.TJART</b>

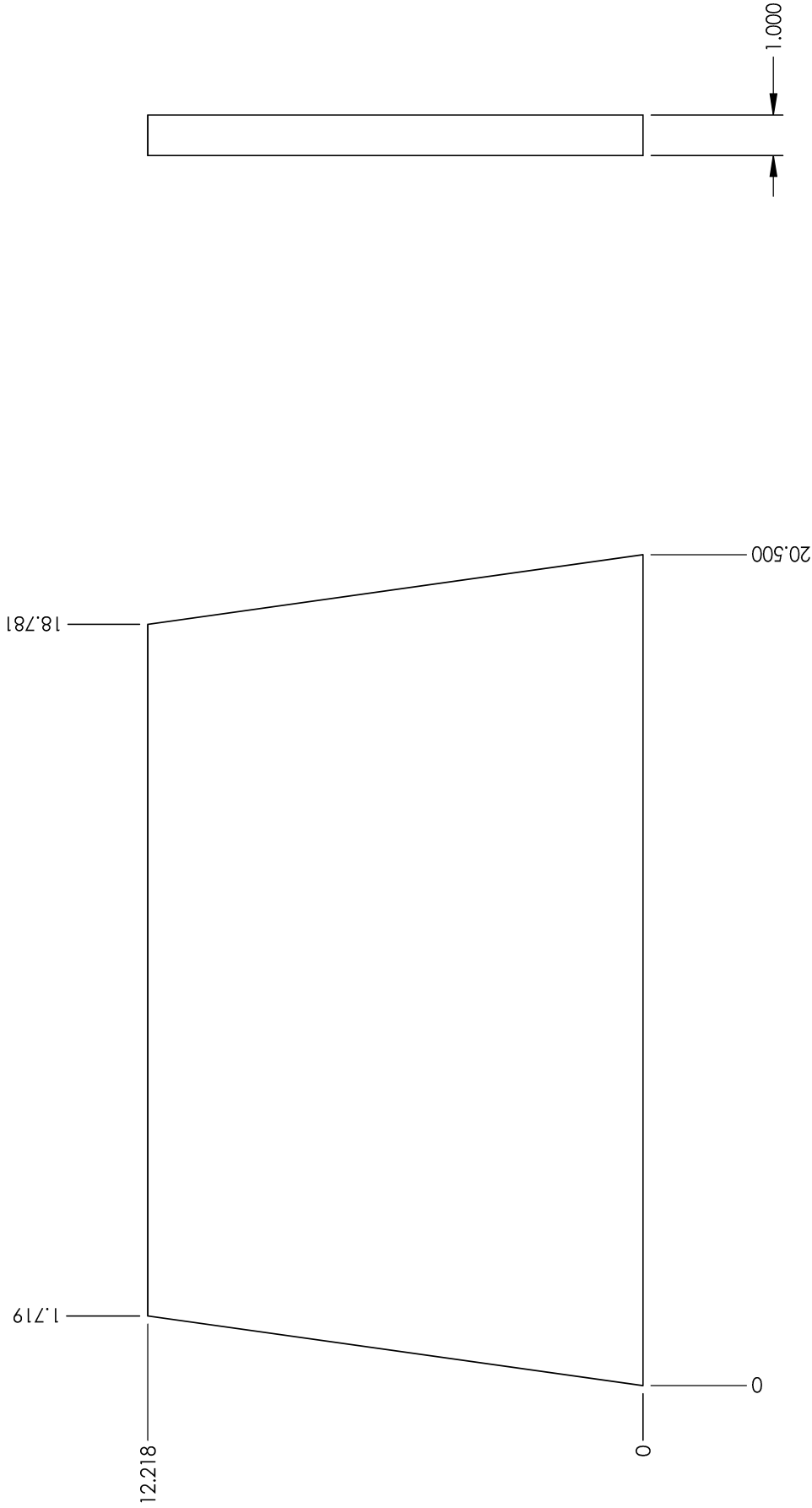

This drawing is the property of Wolf Steel LTD. or NAC. It is to be used only for the project and location specified. All rights are reserved.



01/09/12 AR

UNLESS OTHERWISE NOTED OR DEPICTED  
ALL DIMENSIONS ARE OUTSIDE IN INCHES  
ALL SURFACES ARE CONSIDERED CLASS 10

**TOLERANCES:**

DIMENSIONS ±0.003"  
REFERENCE DIMENSIONS ±0.125"  
ANGLES ±2°

TITLE: **BAFFLE, FIREBOX**

MATERIAL: VERMICULITE V-1100°C (700)

FINISH:

REVISION: -

MODEL:

5.803 LBS

SCALE: 1:4

SHEET 1 OF 1

DRAWING: **W018-0133**

DRAWN BY: **A.RIGDEN**

MM/DD/YYYY: **6/13/2012**

CHECKED BY: **R.TJART**

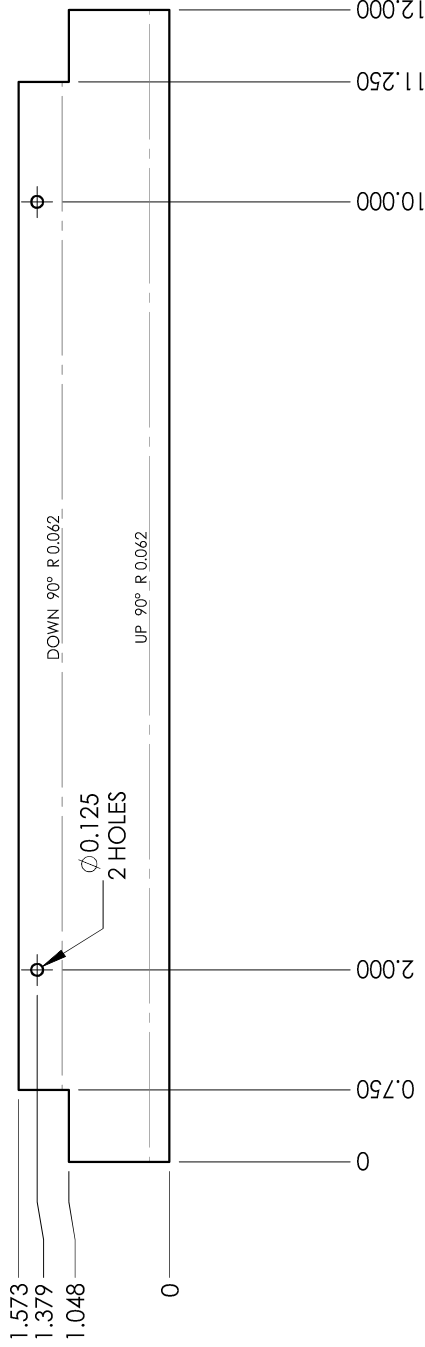
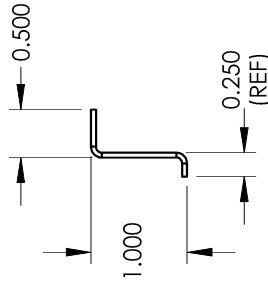

UNLESS OTHERWISE NOTED OR DEPICTED:  
ALL DIMENSIONS ARE IN INCHES UNLESS NOTED OTHERWISE  
ALL SURFACES ARE CONSIDERED CLASS 'D'  
REFER TO ENG-009 AND ENG-010  
FOR SURFACE FINISH CRITERIA

TOLERANCES:  
FORMED PARTS ±0.031 REFERENCE DIMENSIONS ±0.063  
BLANKED PARTS ±0.010 ANGLES ±2

**WOLF STEEL**<sup>TM</sup>  
**NAC**  
NORTH AMERICAN  
CORPORATION

TITLE:	<b>BAFFLE, REAR AIR</b>	MODEL:	EP13	DRAWING:	<b>W018-0145</b>
MATERIAL:	18 GA GALVANNEAL	THICKNESS:	0.051	DRAWN BY:	<b>A.RIGDEN</b>
FINISH:		SCALE:	1:2	SHEET 1 OF 1	<b>2/25/2013</b>
REVISION:	~	CHECKED BY:			<b>R.TJART</b>



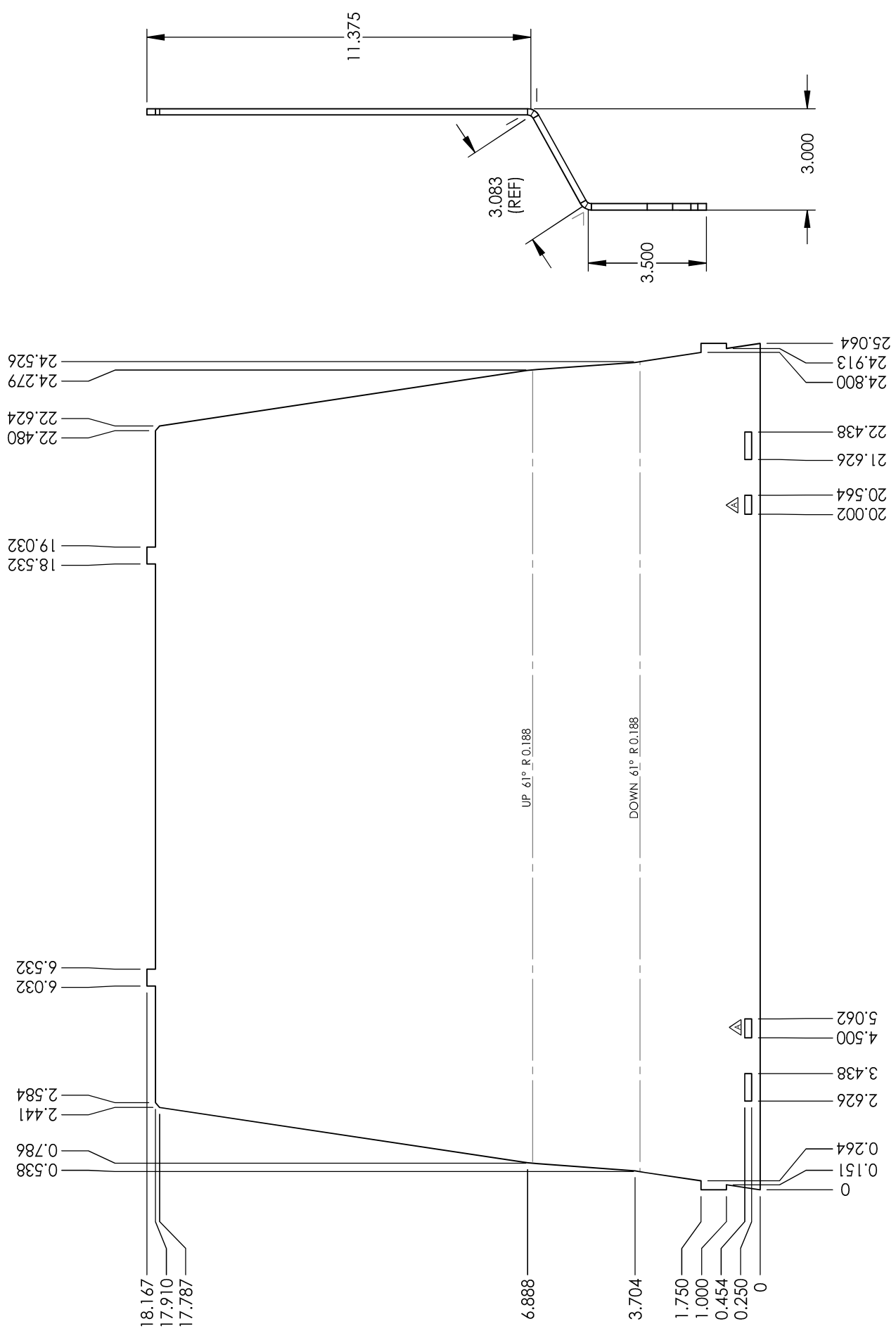

<p><small>This drawing is the property of Wolf Steel LTD. or NAC. It is not to be used, copied, or reproduced in any form without our consent. All rights are reserved.</small></p> <p><b>WOLF STEEL<sup>TM</sup></b>  <b>NAC</b>  <small>Manufactured in Canada</small></p>		<p><b>UNLESS OTHERWISE NOTED OR DEPICTED ALL DIMENSIONS ARE OUTSIDE IN INCHES</b></p> <p><b>TOLERANCES:</b>          WHERE APPLICABLE, FLAT IS SHOWN FINISHED SIDE UP          FORMED PARTS ±0.031"          BLANKED PARTS ±0.010"          REFERENCE DIMENSIONS ±0.063"          ANGLES ±2°</p>		<p><b>TITLE:</b> BASE, FIREBOX</p> <p><b>MATERIAL:</b> 3/16 HR P&amp;O</p> <p><b>FINISH:</b></p>	<p><b>MODEL:</b> EP13</p> <p><b>THICKNESS:</b> 0.188</p> <p><b>SCALE:</b> 1:4</p>	<p><b>DRAWING:</b> W035-0287</p> <p><b>DRAWN BY:</b> A.RIGDEN</p> <p><b>SHEET 1 OF 1</b></p>	<p><b>DATE:</b> 2/11/2013</p> <p><b>REVISION:</b> A</p>	<p><b>DATE:</b> 6/13/2012</p> <p><b>CHECKED BY:</b> R.TJART</p>
<p>UP 61° R.0.188</p> <p>DOWN 61° R.0.188</p>		<p>21.541 LBS</p>	<p>(AGR) ADD SLOTS</p>	<p>20.002</p> <p>20.564</p> <p>21.626</p> <p>22.438</p> <p>24.800</p> <p>24.913</p> <p>25.064</p>	<p>11.375</p> <p>3.000</p> <p>3.500</p> <p>3.083 (REF)</p>	<p>18.532</p> <p>19.032</p> <p>22.480</p> <p>22.624</p> <p>24.279</p> <p>24.526</p>	<p>18.167</p> <p>17.910</p> <p>17.787</p> <p>6.888</p> <p>3.704</p> <p>1.750</p> <p>1.000</p> <p>0.454</p> <p>0.250</p> <p>0</p> <p>0.151</p> <p>0.264</p> <p>2.626</p> <p>3.438</p> <p>4.500</p> <p>5.062</p>	

NOTES:

- 1 PART IS NOT SYMMETRICAL  $\triangle B$
- 2 FORM PART TO DRAWING REGARDLESS OF BUR DIRECTION

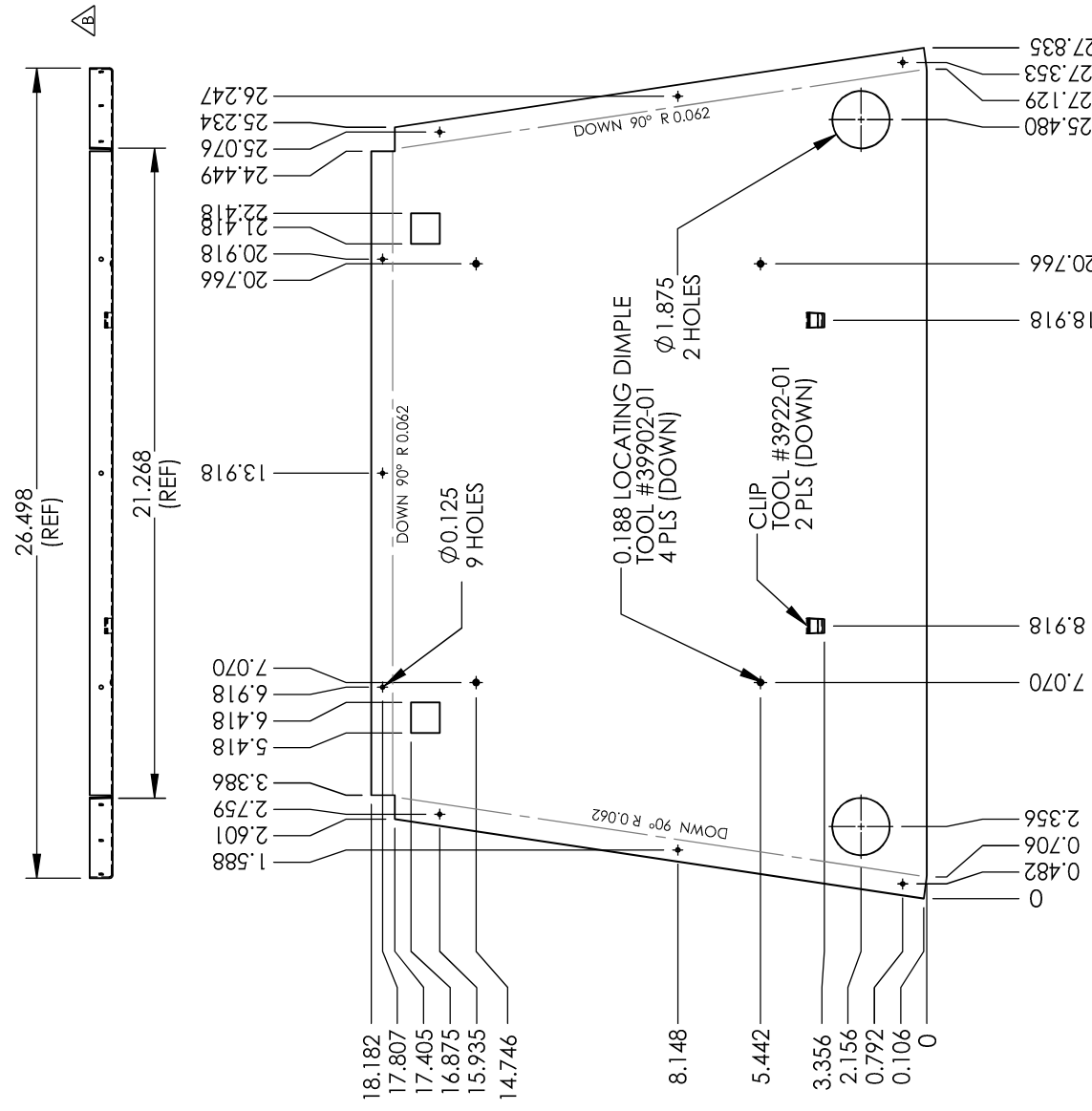
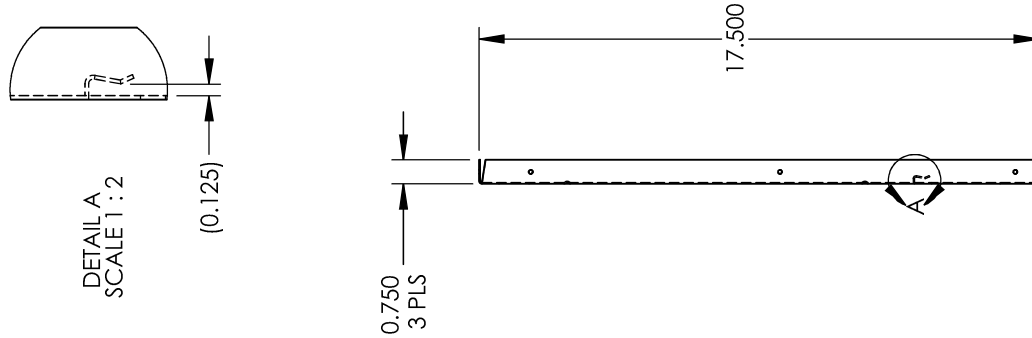

UNLESS OTHERWISE NOTED OR DEPICTED ALL DIMENSIONS ARE OUTSIDE IN INCHES ALL SURFACES ARE CONSIDERED CLASS "D" REFER TO ENG-009 AND ENG-010 FOR SURFACE FINISH CRITERIA	TITLE: <b>BASE, OUTER SHELL</b>	MODEL:	EPI3 DRAWING: <b>W035-0288</b>
	MATERIAL: 20 GA GALVANNEAL	THICKNESS: 0.039	DRAWN BY: <b>A.RIGDEN</b>
FINISH:	REVISION: <b>B</b>	SCALE: 1:6	SHEET 1 OF 1
TOLERANCES: FORMED PARTS ±0.031 REFERENCE DIMENSIONS ±0.063 BLANKED PARTS ±0.010 ANGLES ±2°	MM/DD/YY: <b>10/30/2015</b> (AGR) ADD VIEW/ADD NOTES	CHECKED BY:	6/13/2012
08/27/15 AGR	1	4	5



This drawing is the property of Wolf Steel LTD. or NAC. It is to be used only for the project and location specified on the drawing. All rights are reserved.

NOTE: BREAK ALL EDGES

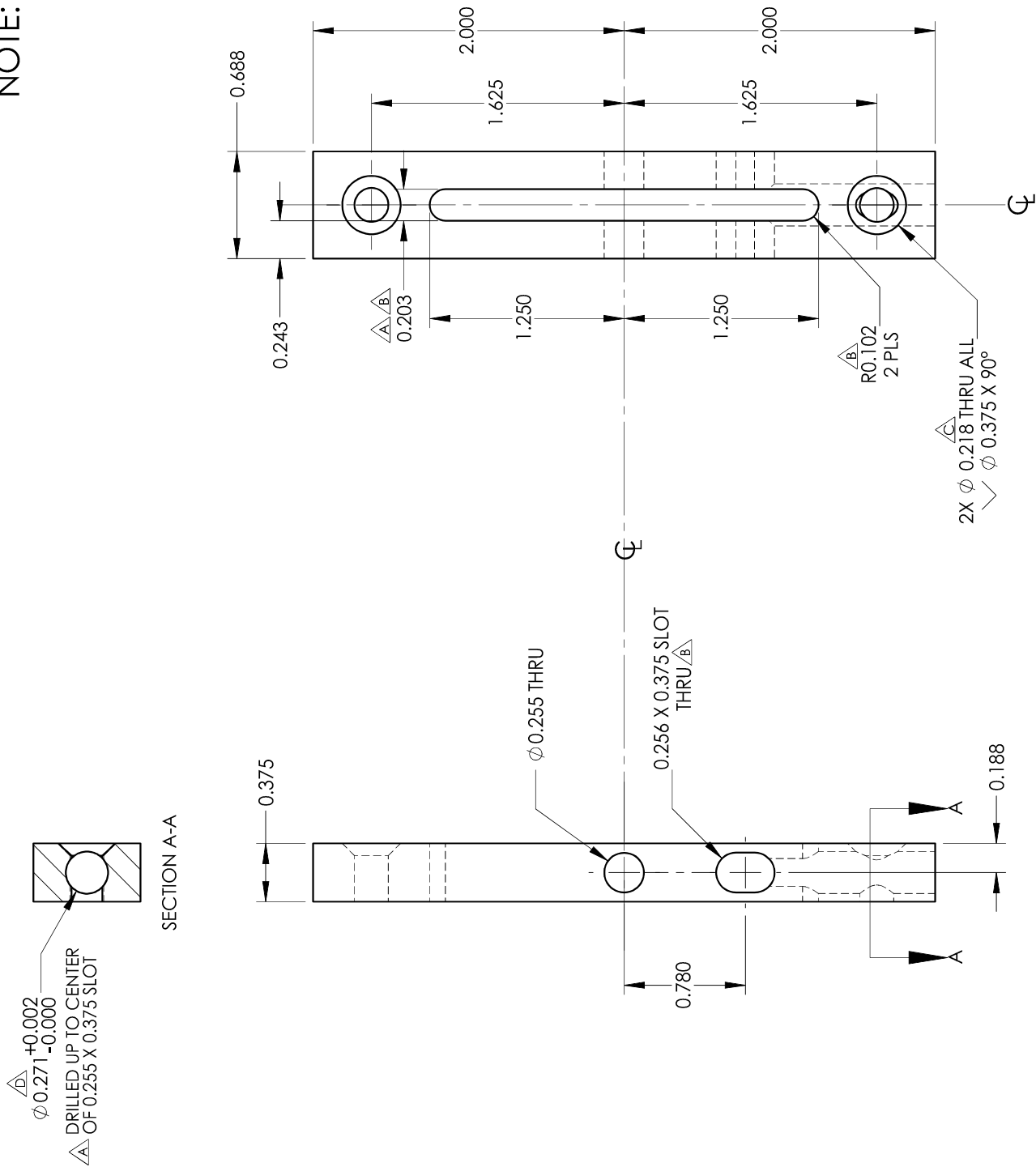

$\Delta$  +0.002  
 $\phi$  0.271 -0.000  
 DRILLED UP TO CENTER  
 OF 0.255 X 0.375 SLOT

UNLESS OTHERWISE NOTED OR DEPICTED ALL DIMENSIONS ARE OUTSIDE IN INCHES ALL SURFACES ARE CONSIDERED CLASS 10 DIMENSIONS $\pm 0.005"$ ANGLES $\pm 1$ TOLERANCES:	TITLE:	<b>BLOCK, DOOR LATCH</b>	MODEL:	S4	DRAWING:	<b>W060-0012</b>
	MATERIAL:	CRS		0.200 LBS	DRAWN BY:	<b>J.DUCHESNE</b>
	FINISH:	BLACK OXIDE		SHEET 1 OF 1	MM/DD/YYYY:	<b>10/30/2012</b>
	REVISION:	<b>D</b>	<b>6/27/2013</b>	(JMD) REVISED HOLE DIAMETER	CHECKED BY:	<b>R.TJART</b>

The drawing is the property of Wolf Steel LTD. or NAC. It is to be used only for the project and for the quantity specified. All rights are reserved.

**WOLF STEEL**<sup>TM</sup>  
**NAC**  
 Precision in  
 Architecture  
 Construction

10/09/12 AR

Thread Size 5/16" - 18  
 Width (A) 0.625"  
 Thickness (B) 0.139"  
 Length of Leg from End to Angle (C) 0.985"  
 (C1) 0.985"  
 Centre of Hole to Angle (D) 0.609"  
 Pilot Diameter (E) 0.349"  
 Pilot Height (F) 0.08"  
 Projection Width (G) 0.136"  
 Projection Height (H) 0.022"  
 Projection Length (I) 0.126"  
 Material High-Welding Quality,  
 Low Carbon Steel  
 Finish Plain  
 Threads Unified Standard Class 2B

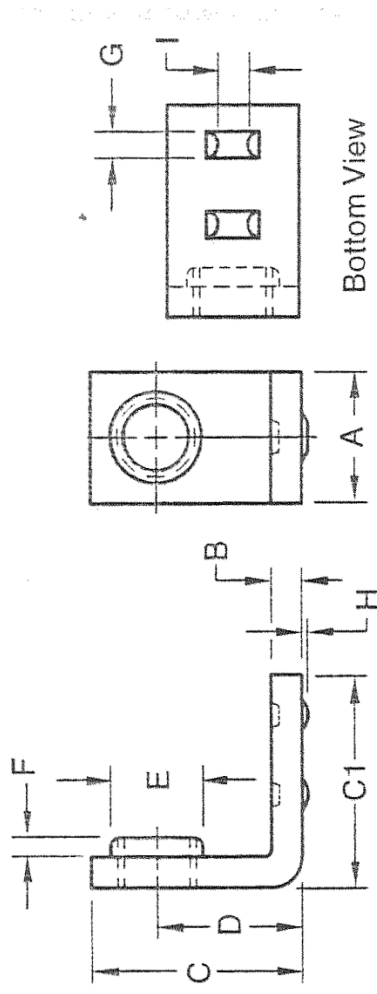

WOLF STEEL LTD

DIMS: INCHES

TITLE: BRACKET, 5/16-18 x 5/8"

DWG#: W080-0209

REV:

DATE: 06.15.11\_JFK

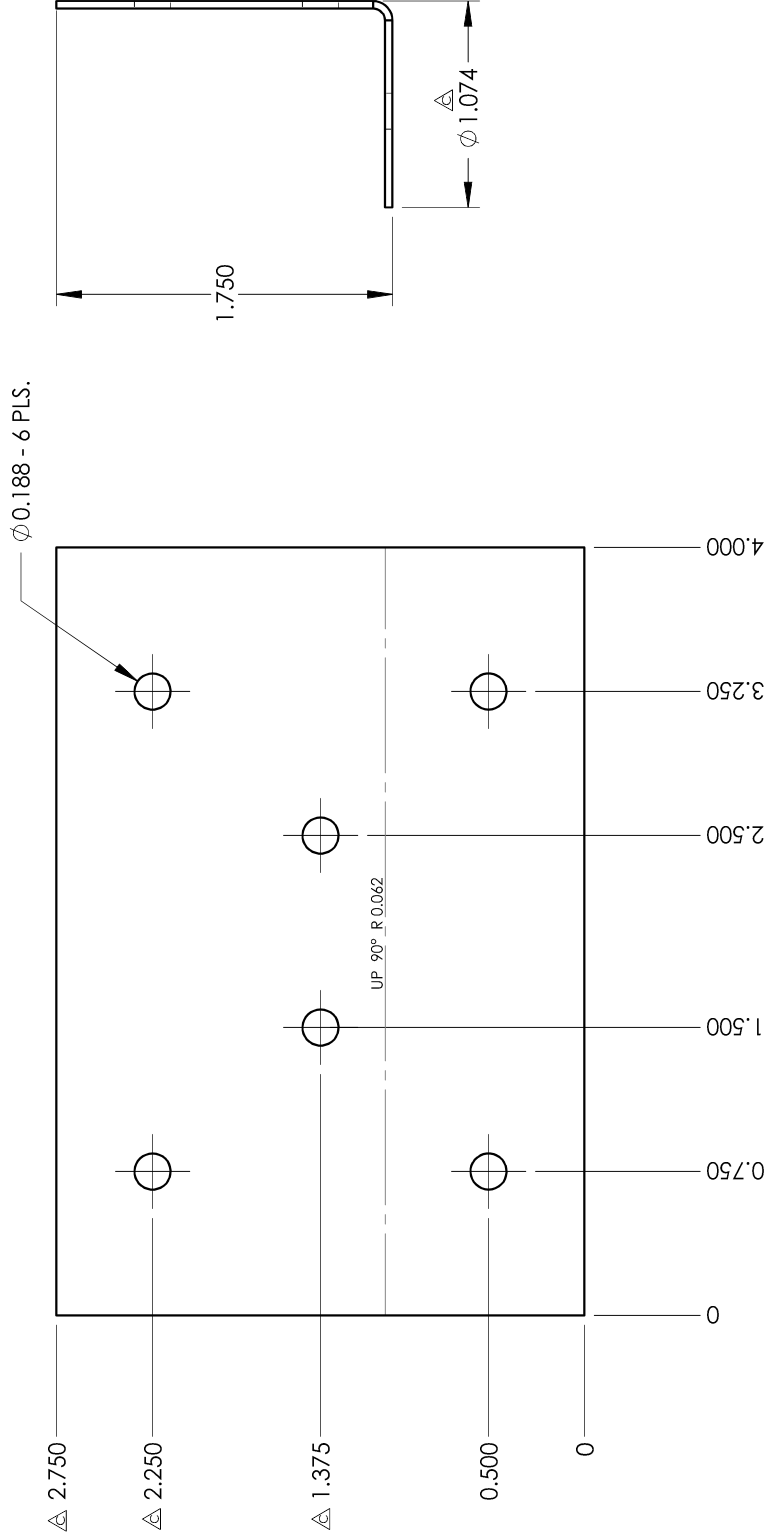

UNLESS OTHERWISE NOTED OR DEPICTED ALL DIMENSIONS ARE OUTSIDE IN INCHES WHERE APPLICABLE. FINISH IS SHOWN FINISHED SIDE UP TOLERANCES: FORMED PARTS ±0.031" BURNED PARTS ±0.063" SURFACE DIMENSIONS ±.2° ANGLES	TITLE: <b>BRACKET, SHIPPING</b>	MODEL:	DRAWING: <b>W080-0245</b>
	MATERIAL: 20 GA GALVANNEAL	THICKNESS: 0.039	DRAWN BY: <b>JTA</b>
FINISH:	SCALE: 1:1	SHEET 1 OF 1	MM/DD/YYYY: <b>7/20/1994</b>
REVISION: <b>C</b>	DATE: <b>12/3/2015</b>	(JDP) MODIFY DIMS/HOLE POSITIONS	CHECKED BY: <b>R.TJART</b>

This drawing is the property of Wolf Steel LTD., or NAC.  
 It is not to be reproduced, stored in a retrieval system,  
 or transmitted in any form or by any means, electronic,  
 mechanical, photocopying, recording, or by any information  
 storage and retrieval system, without our consent. All rights are reserved.

**WOLF STEEL**<sup>TM</sup>  
**NAC**  
 NORTH AMERICAN  
 CORRUGATED SHEET  
 COMPANY

01.09.12 AR

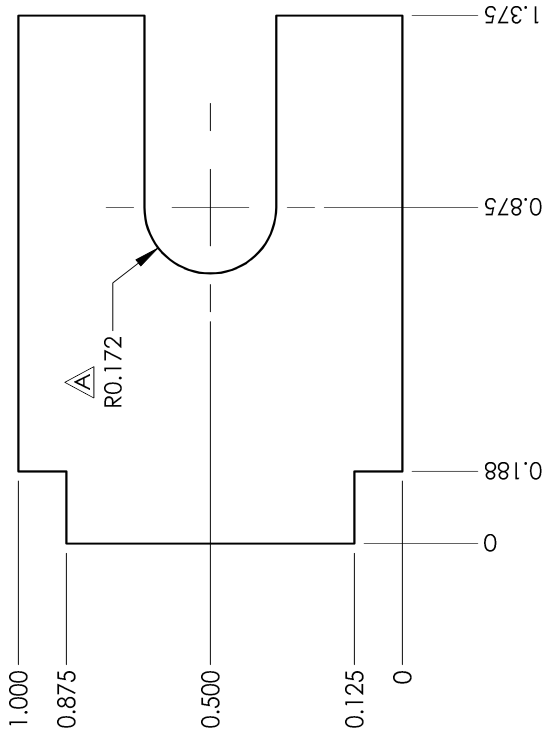

UNLESS OTHERWISE NOTED OR DEPICTED  
 ALL DIMENSIONS ARE OUTSIDE IN INCHES  
 TOLERANCES:  
 WHERE APPLICABLE, FLAT IS SHOWN FINISHED SIDE UP  
 FORMED PARTS ±0.031"  
 BLANKED PARTS ±0.010"  
 REFERENCE DIMENSIONS ±0.063"  
 ANGLES ±2°

TITLE: **BRACKET, CASTING MOUNT**  
 MATERIAL: 3/16 HR P&O  
 FINISH:  
 REVISION: **A** 06/12/17 (RB) INCREASED SLOT DIA

MODEL: EP13  
 THICKNESS: 0.188  
 SCALE: 2:1  
 SHEET 1 OF 1  
 DRAWING: **W080-1161**  
 DRAWN BY: **A.RIGDEN**  
 MM/DD/YYYY: **06/13/12**  
 CHECKED BY: **CLIFF**

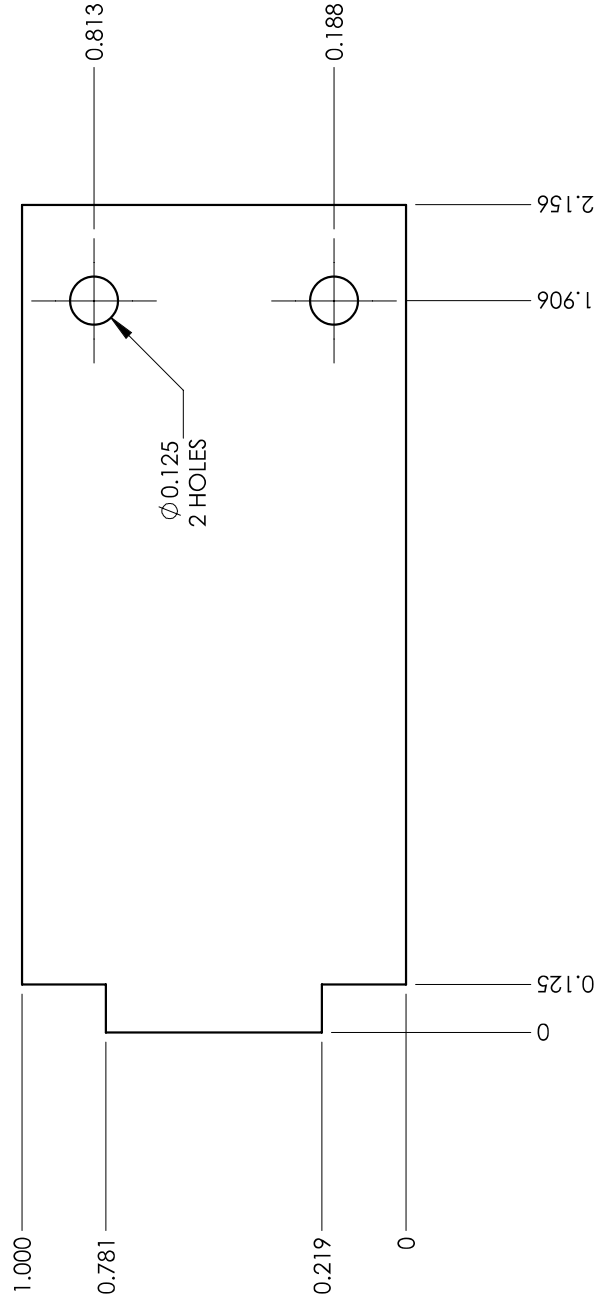

<p><small>This drawing is the property of Wolf Steel Ltd., or NAC. It is to be used only for the part and project identified hereon without our consent. All rights are reserved.</small></p> <p><b>WOLF STEEL</b><sup>ltd.</sup> Napoleon America Corporation <b>NAC</b></p>	<p><b>UNLESS OTHERWISE NOTED OR DEPICTED ALL DIMENSIONS ARE OUTSIDE IN INCHES</b></p> <p><b>TOLERANCES:</b> WHERE APPLICABLE, FLAT IS SHOWN FINISHED SIDE UP</p> <p>FORMED PARTS ±0.031" BLANKED PARTS ±0.010" REFERENCE DIMENSIONS ±0.063" ANGLES ±2</p>	<p><b>TITLE:</b> BRACKET, AIR CONTROL</p> <p><b>MATERIAL:</b> 14 GA HR P&amp;O</p> <p><b>FINISH:</b></p> <p><b>REVISION:</b> -</p>	<p><b>MODEL:</b> EP13</p> <p><b>THICKNESS:</b> 0.044 LBS</p> <p><b>SCALE:</b> 2:1</p>	<p><b>DRAWING:</b> W080-1176</p> <p><b>DRAWN BY:</b> A.RIGDEN</p> <p><b>MM/DD/YYYY:</b> 06/13/12</p> <p><b>CHECKED BY:</b> R.TJART</p>
	<p><b>SHEET 1 OF 1</b></p>			

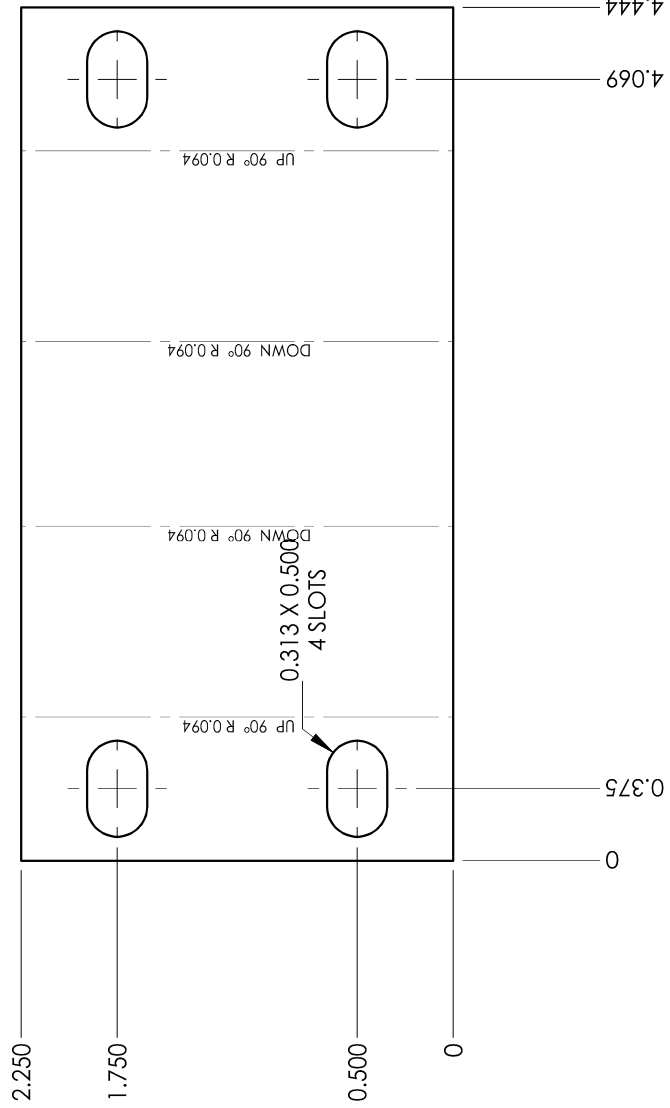
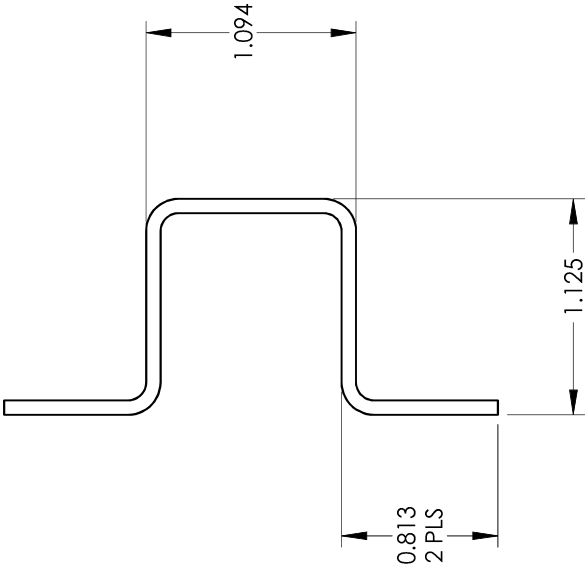

<p>UNLESS OTHERWISE NOTED OR DEPICTED ALL DIMENSIONS ARE OUTSIDE IN INCHES WHERE APPLICABLE. FINISH IS SHOWN FINISHED SIDE UP</p> <p>TOLERANCES: FORMED PARTS: ±0.031" BURNED PARTS: ±0.063" SURFACE DIMENSIONS: ±0.063" ANGLES: ±2°</p>	TITLE:	BRACKET, CASTING	MODEL:	EPI3C	DRAWING:	W080-1234
	MATERIAL:	14 GA HR P&O	THICKNESS:	0.075	DRAWN BY:	A.RIGDEN
FINISH:		SCALE:	1:1	SHEET 1 OF 1	MM/DD/YYYY:	6/13/2012
REVISION:	-	CHECKED BY:				R.TJART

This drawing is the property of Wolf Steel LTD., or NAC. It is to be used only for the project and order number shown hereon. All rights are reserved.

**WOLF STEEL**<sup>TM</sup>  
**NAC**

Manufactured in  
Canada

01/09/12 AR





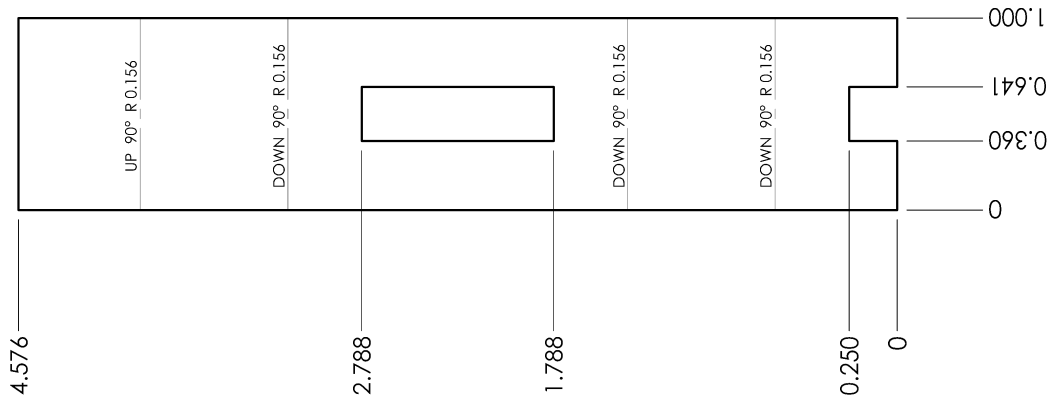
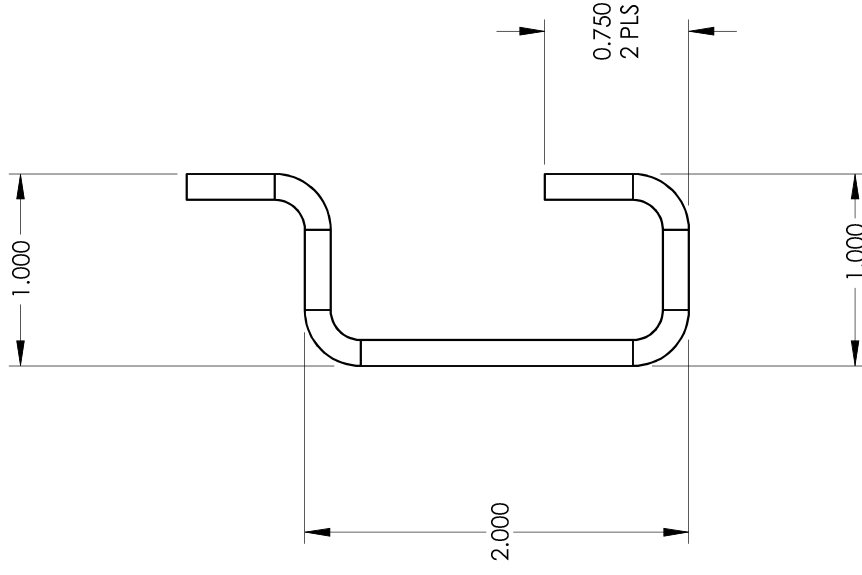

UNLESS OTHERWISE NOTED OR DEPICTED  
 ALL DIMENSIONS ARE OUTSIDE IN INCHES  
 UNLESS OTHERWISE NOTED  
 WHERE APPLICABLE, FLAT IS SHOWN FINISHED SIDE UP

TOLERANCES:  
 FORMED PARTS ±0.031"  
 BEVELLED PARTS ±0.063"  
 SURFACE DIMENSIONS ±.2°  
 ANGLES

**WOLF STEEL**<sup>TM</sup>  
**NAC**  
 NORTH AMERICAN  
 CORRUGATED STEEL  
 COMPANY

TITLE:	<b>BRACKET, LOG RETAINER</b>	MODEL:	EP13	DRAWING:	<b>W080-1284</b>
MATERIAL:	10 GA HR P&O	THICKNESS:	0.135	DRAWN BY:	<b>A.RIGDEN</b>
FINISH:		SCALE:	1:1	SHEET 1 OF 1	<b>6/13/2012</b>
REVISION:	~	CHECKED BY:			<b>R.TJART</b>

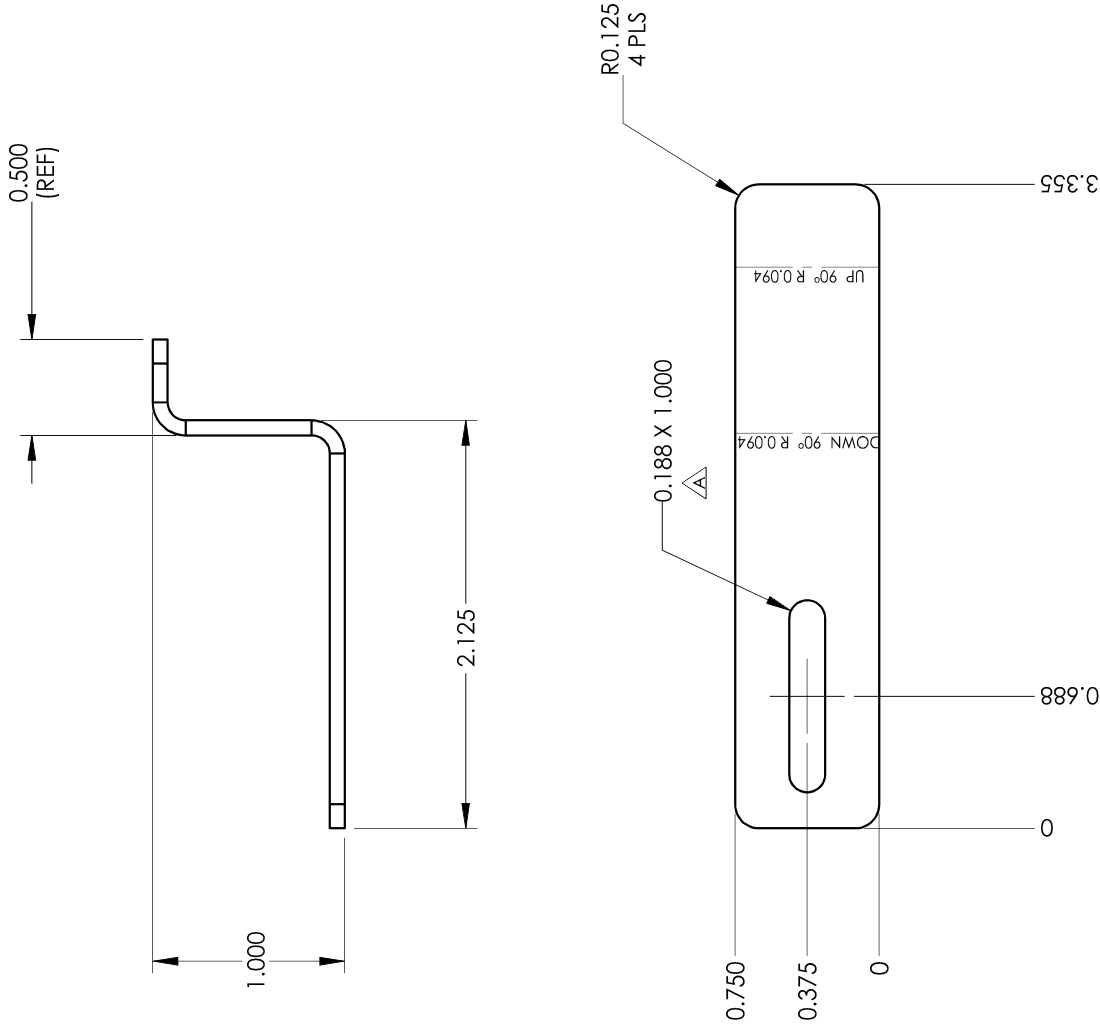

UNLESS OTHERWISE NOTED OR DEPICTED  
 ALL DIMENSIONS ARE OUTSIDE IN INCHES  
 SURFACES ARE TO BE SMOOTHED AND FINISHED SIDE UP  
 WHERE APPLICABLE TO ENGINTEERING AND ENG-010  
 FOR SURFACE FINISH CRITERIA

TOLERANCES:  
 FORMED PARTS ±0.031" REFERENCE DIMENSIONS ±0.063"  
 BLANKED PARTS ±0.010" ANGLES ±2°

10/09/12 AR

**WOLF STEEL**<sup>TM</sup>  
**NAC**  
 NORTH AMERICAN  
 CORPORATION

TITLE:	BRACKET, FAN SWITCH	MODEL:	EPT3	DRAWING:	W080-1306
MATERIAL:	14 GA HR P&O	THICKNESS:	0.078	DRAWN BY:	A.RIGDEN
FINISH:		SCALE:	1:1	SHEET 1 OF 1	MM/DD/YYYY: 2/1/2013
REVISION:	A			CHECKED BY:	
(SDE) INCREASED SLOT					

D

C

B

A

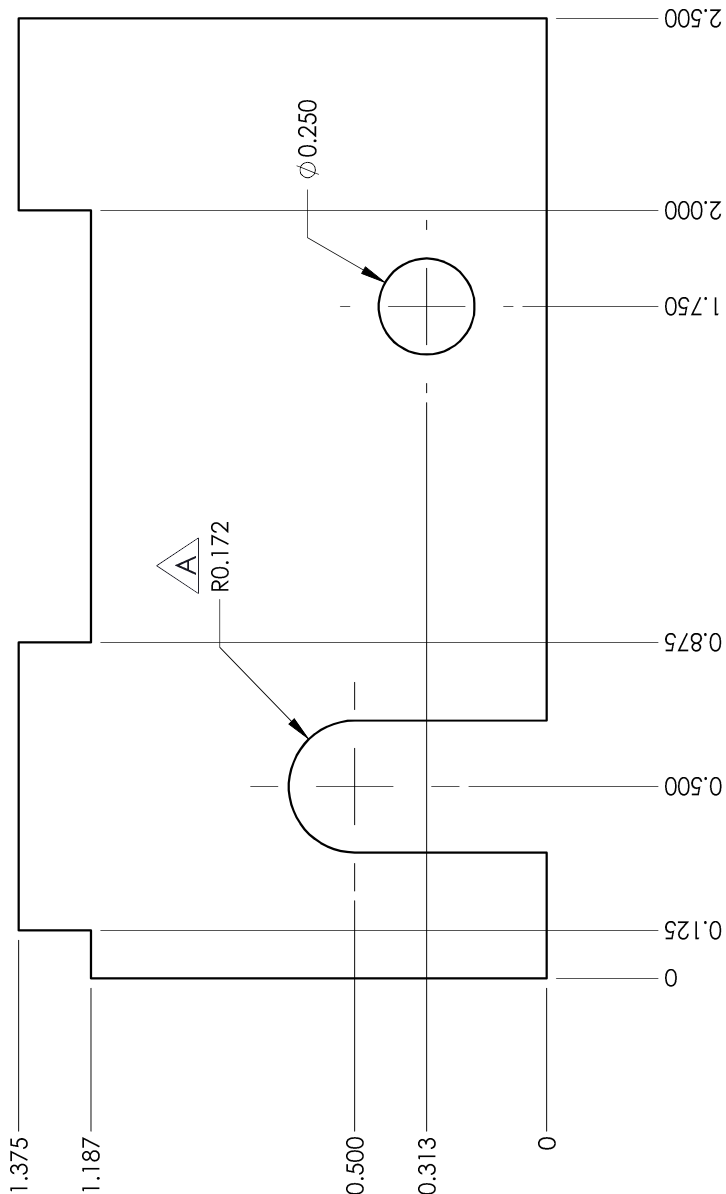

<small>This drawing is the property of Wolf Steel LTD. or NAC. It is not to be reproduced, stored in a retrieval system, or transmitted in any form or by any means, without our consent. All rights are reserved.</small> <b>WOLF STEEL LTD.</b> <b>NAC</b> <small>Manufacturing Solutions</small>	<small>UNLESS OTHERWISE NOTED OR DEPICTED ALL DIMENSIONS ARE OUTSIDE IN INCHES. ALL SURFACES ARE CONSIDERED CLASS "D" REFER TO ENG-009 AND ENG-010 FOR SURFACE FINISH CRITERIA</small>	<small>TOLERANCES:          FORMED PARTS ±0.031 REFERENCE DIMENSIONS ±0.063          BLANKED PARTS ±0.010 ANGLES ±2°</small>	<b>TITLE:</b> BRACKET, CASTING MOUNT (LOWER)	<b>MODEL:</b>	<b>EPI3 DRAWING:</b> W080-1307
	<small>FORMED PARTS ±0.031 REFERENCE DIMENSIONS ±0.063          BLANKED PARTS ±0.010 ANGLES ±2°</small>	<b>MATERIAL:</b> 3/16 HR P&O	<b>FINISH:</b>	<b>THICKNESS:</b> 0.155 LBS	<b>DRAWN BY:</b> Husaish
	<b>REVISION:</b> A	<b>REV DATE:</b> 9/14/2017	<b>INCREASED SLOT DIAMETER</b>	<b>SCALE:</b> 2:1	<b>ISSUE DATE:</b>
				<b>CN#:</b>	<b>SHEET 1 OF 1</b>
					<b>CHECKED BY:</b> CL

D

C

B

A

1

08/01/17 by G.R.

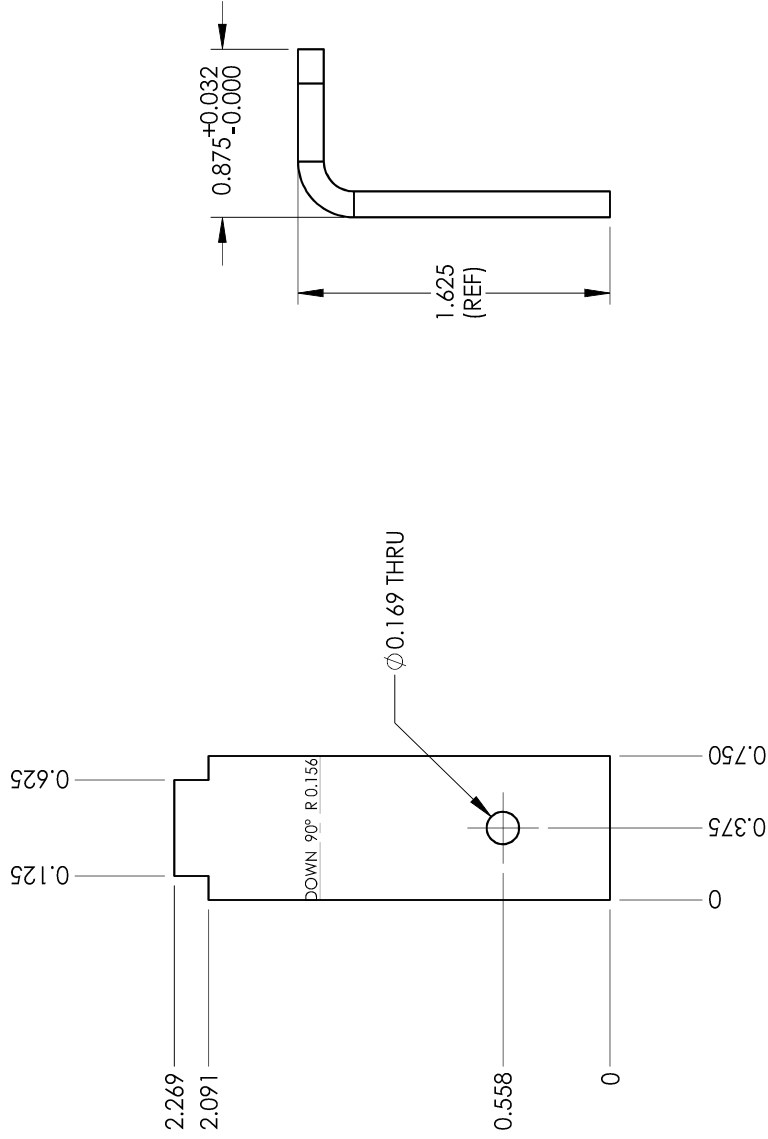

UNLESS OTHERWISE NOTED OR DEPICTED:  
 ALL DIMENSIONS ARE REFERENCED TO CLASS 'D'  
 ALL SURFACES ARE CONSIDERED CLASS 'D'  
 REFER TO ENG-009 AND ENG-010  
 FOR SURFACE FINISH CRITERIA

TOLERANCES:  
 FORMED PARTS ±0.031 REFERENCE DIMENSIONS ±0.063  
 BLANKED PARTS ±0.010 ANGLES ±2

**WOLF STEEL**<sup>TM</sup>
  
**NAC**
  
 NAC Steel Inc.
   
 10000 N. 10th St.
   
 Aurora, CO 80010-3447

TITLE:	BRACKET, DOOR ROLLER (REPL W080-1283)	MODEL:	EPI3C	DRAWING:	W080-1336
MATERIAL:	10 GA HR P&O	THICKNESS:	0.135	DRAWN BY:	A.RIGDEN
FINISH:		SCALE:	1:1	SHEET 1 OF 1	9/4/2013
REVISION:	-	WEIGHT:	0.062 LBS	CHECKED BY:	R.TJART

MADE FROM HYDRAULIC SETTING, CLAY BASE  
 CASTABLE FORMULATED WITH A MEDIUM GRIND  
 HIGH TEMP. CALCINED AGGREGATE.  
 APPROX DENSITY 130# PER CU. FT

NOTE: ALL DRAFTS 5° EXCEPT WERE NOTED

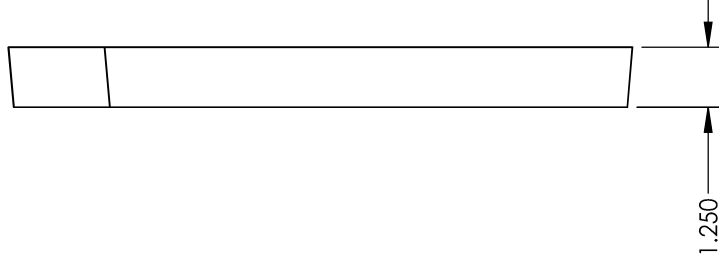
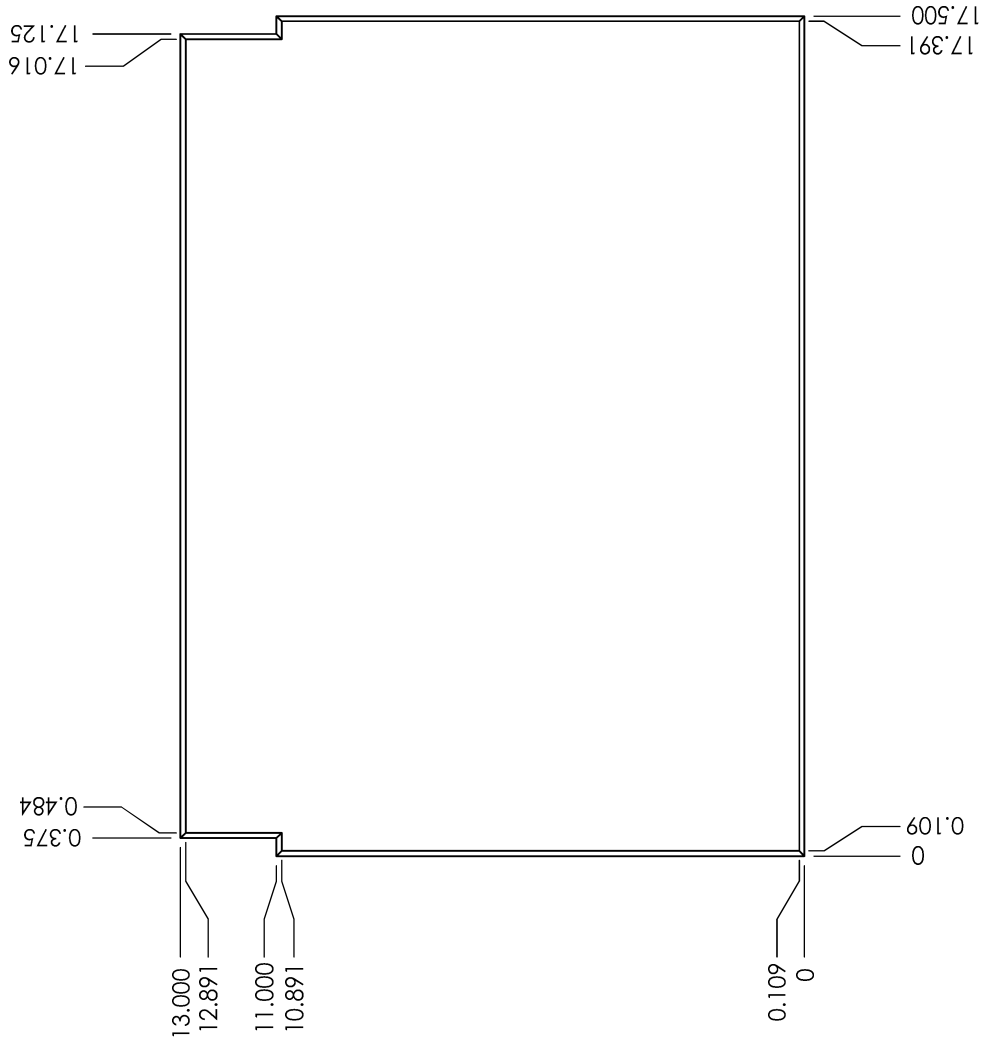
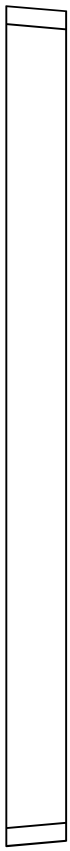

UNLESS OTHERWISE NOTED OR DEPICTED ALL DIMENSIONS ARE OUTSIDE IN INCHES TOLERANCES: DIMENSIONS ±0.125" ANGLES ±1°	TITLE: <b>BRICK, REAR</b>	MODEL:	EPT3	DRAWING: <b>W090-0190</b>
	MATERIAL: REFRACTORY	20.876 LBS	DRAWN BY: <b>A.RIGDEN</b>	SCALE: 1:4
FINISH:	SHEET 1 OF 1	MM/DD/YYYY:	4/30/2012	CHECKED BY:
REVISION: ~	R.TJART	R.TJART		



MADE FROM HYDRAULIC SETTING, CLAY BASE  
 CASTABLE FORMULATED WITH A MEDIUM GRIND  
 HIGH TEMP. CALCINED AGGREGATE.  
 APPROX DENSITY 130# PER CU. FT

NOTE: ALL DRAFTS 5° EXCEPT WHERE NOTED

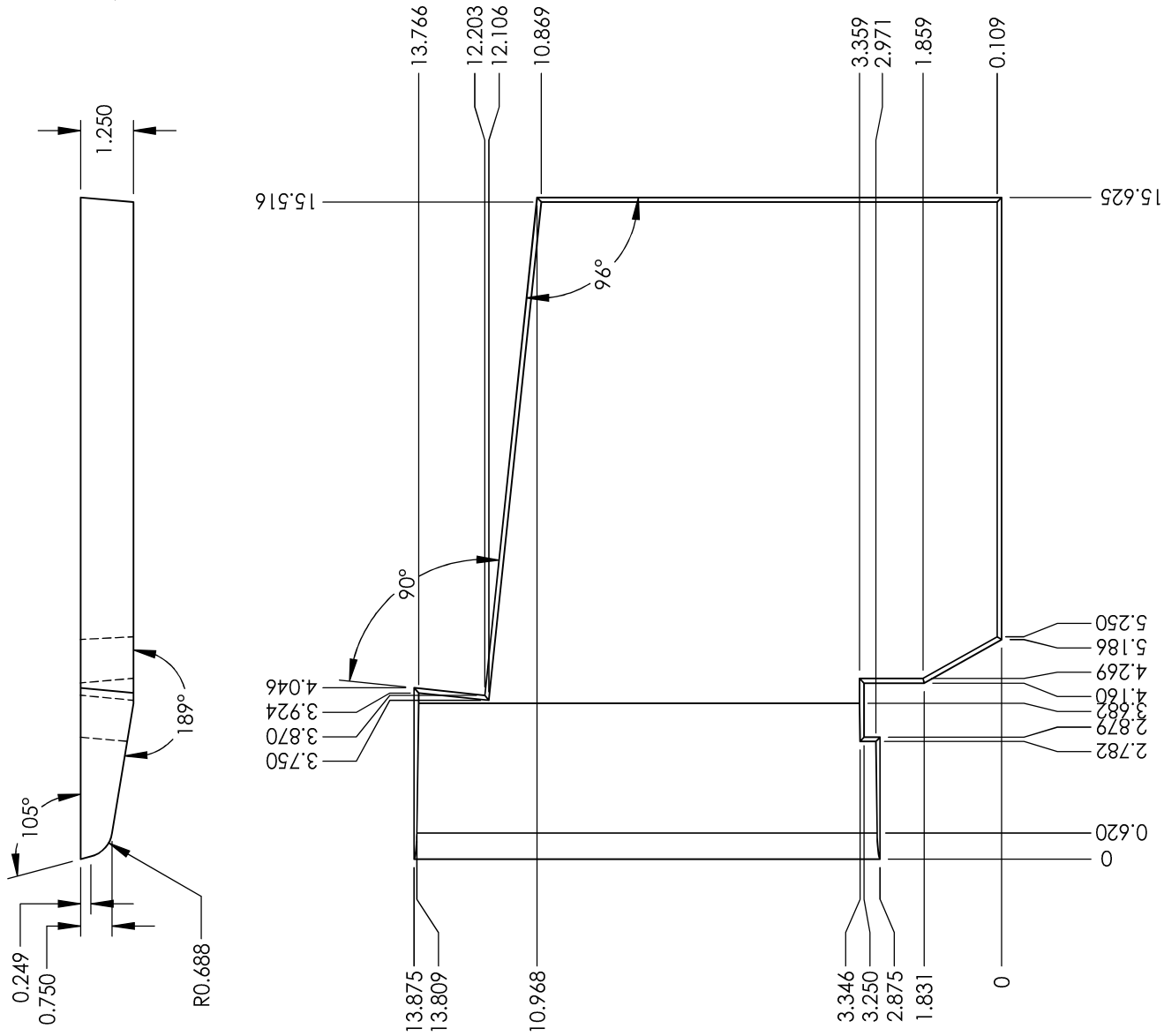

UNLESS OTHERWISE NOTED OR DEPICTED ALL DIMENSIONS ARE OUTSIDE IN INCHES DIMENSIONS ±0.125" ANGLES ±1°	TITLE: <b>BRICK, LEFT SIDE</b>	MODEL: EP13	DRAWING: <b>W090-0191</b>
	MATERIAL: REFRACTORY	15.348 LBS	DRAWN BY: <b>A.RIGDEN</b>
FINISH:	SCALE: 1:4	SHEET 1 OF 1	MM/DD/YYYY: <b>4/30/2012</b>
REVISION: ~		CHECKED BY: <b>R.TJART</b>	



MADE FROM HYDRAULIC SETTING, CLAY BASE  
 CASTABLE FORMULATED WITH A MEDIUM GRIND  
 HIGH TEMP. CALCINED AGGREGATE.  
 APPROX DENSITY 130# PER CU. FT

NOTE: ALL DRAFTS 5° EXCEPT WHERE NOTED

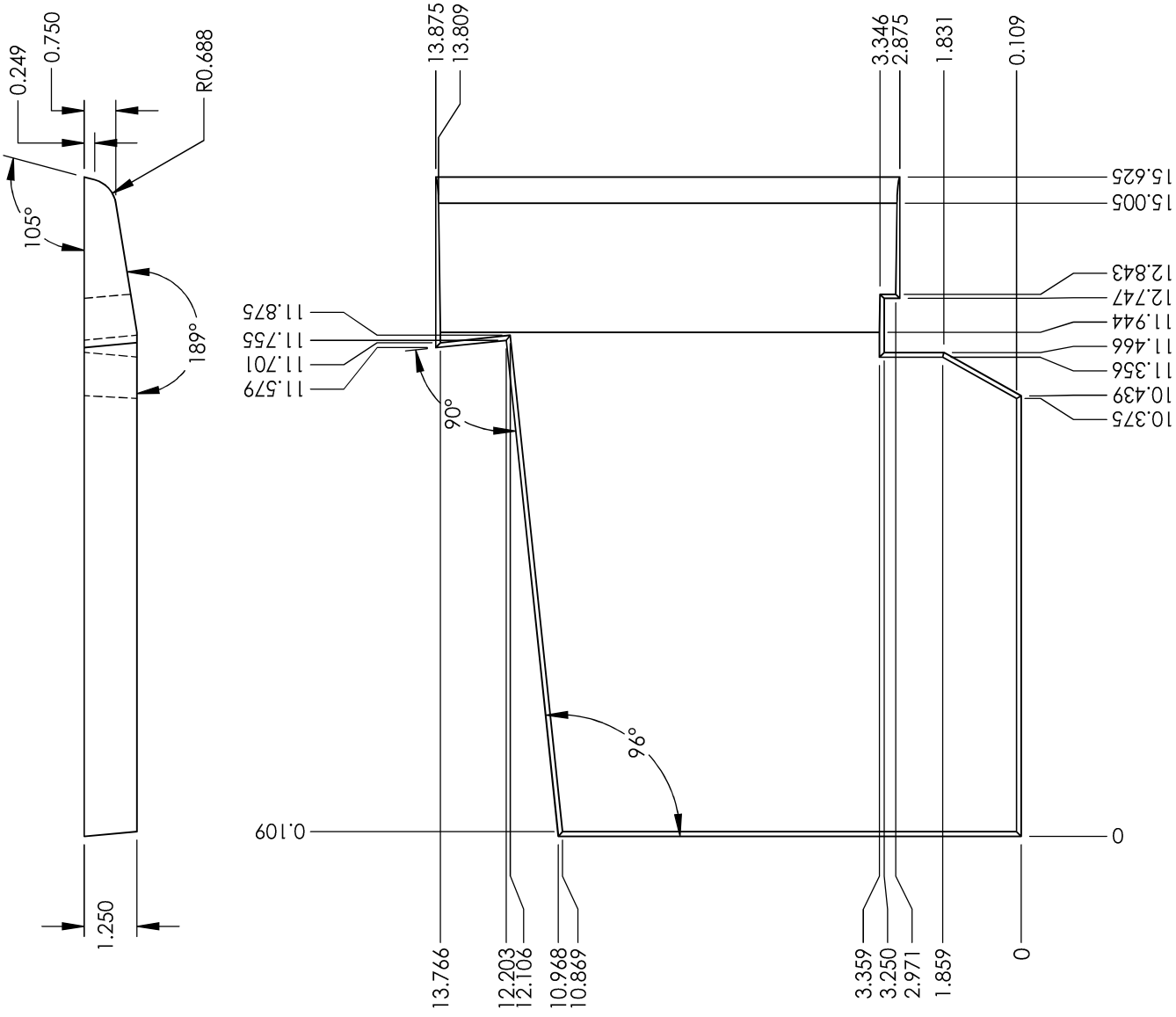

UNLESS OTHERWISE NOTED OR DEPICTED ALL DIMENSIONS ARE OUTSIDE IN INCHES TOLERANCES: DIMENSIONS ±0.125" ANGLES ±1°		TITLE: <b>BRICK, RIGHT SIDE</b> MATERIAL: REFRACTORY FINISH: REVISION: 2	MODEL: EP13 MODEL: 15.348 LBS SCALE: 1:4 SHEET 1 OF 1	DRAWING: <b>W090-0192</b> DRAWN BY: <b>A.RIGDEN</b> MM/DD/YYYY: <b>4/30/2012</b> CHECKED BY: <b>R.TJART</b>
---	--	---	--	--





MADE FROM HYDRAULIC SETTING, CLAY BASE  
CASTABLE FORMULATED WITH A MEDIUM GRIND  
HIGH TEMP. CALCINED AGGREGATE.  
APPROX DENSITY 130# PER CU. FT

NOTE: ALL DRAFTS 5° EXCEPT WERE NOTED

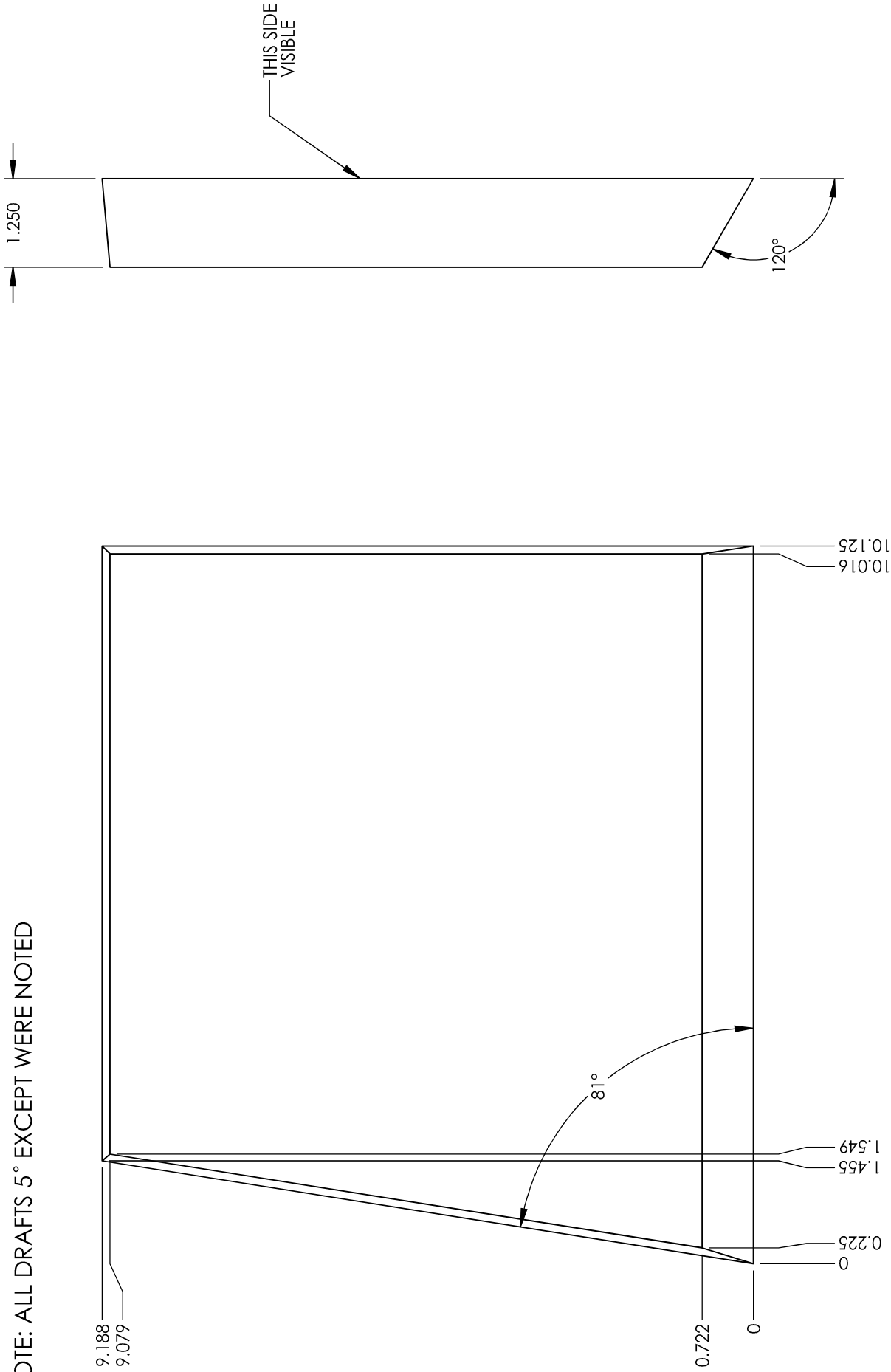

<small>This drawing is the property of Wolf Steel LTD. or NAC. It is to be used for the project and for the material specified herein without our consent. All rights are reserved.</small>		<b>UNLESS OTHERWISE NOTED OR DEPICTED ALL DIMENSIONS ARE OUTSIDE IN INCHES</b>		<b>TITILE: BRICK, BOTTOM (RS)</b>		<b>MODEL: EP13</b>		<b>DRAWING: W090-0193</b>	
<b>DIMENSIONS</b> ±0.125"		<b>MATERIAL: REFRACTORY</b>		<b>MATERIAL: 7.620 LBS</b>		<b>SCALE: 1:2</b>		<b>DRAWN BY: A.RIGDEN</b>	
<b>ANGLES</b> ±1°		<b>FINISH:</b>		<b>FINISH:</b>		<b>SHEET 1 OF 1</b>		<b>MM/DD/YYYY: 4/30/2012</b>	
<b>REVISION:</b> ~		<b>REVISION:</b>		<b>REVISION:</b>		<b>CHECKED BY: R.TJART</b>		<b>CHECKED BY:</b>	



MADE FROM HYDRAULIC SETTING, CLAY BASE  
 CASTABLE FORMULATED WITH A MEDIUM GRIND  
 HIGH TEMP. CALCINED AGGREGATE.  
 APPROX DENSITY 130# PER CU. FT

NOTE: ALL DRAFTS 5° EXCEPT WHERE NOTED

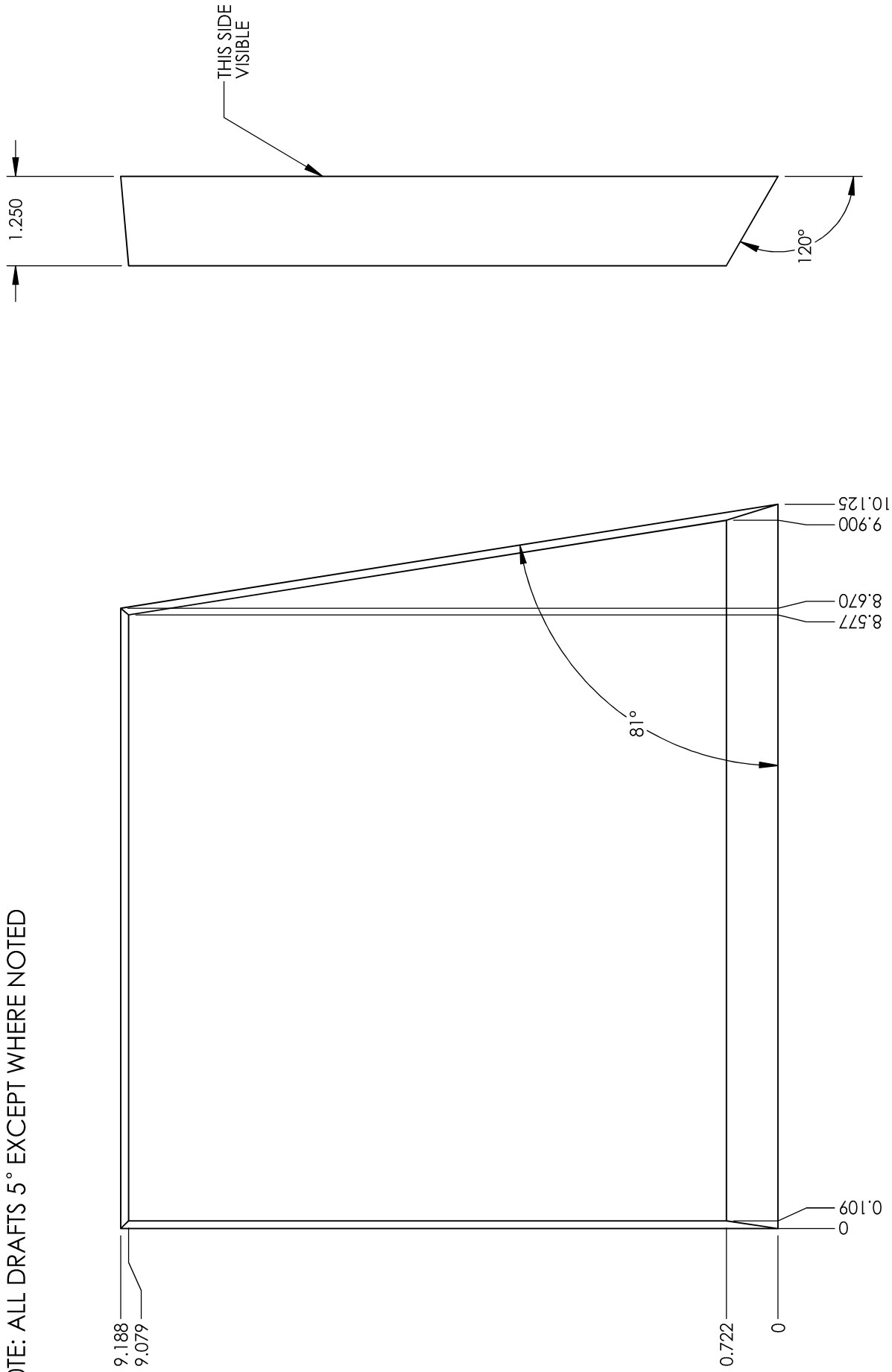

UNLESS OTHERWISE NOTED OR DEPICTED ALL DIMENSIONS ARE OUTSIDE IN INCHES TOLERANCES: DIMENSIONS ±0.125" ANGLES ±1°	TITLE: <b>BRICK, BOTTOM (LS)</b>	MODEL: EP13	DRAWING: <b>W090-0194</b>
	MATERIAL: REFRACTORY	7.620 LBS	DRAWN BY: <b>A.RIGDEN</b>
FINISH:	SCALE: 1:2	SHEET 1 OF 1	MM/DD/YYYY: <b>4/30/2012</b>
REVISION: ~	CHECKED BY:	R.TJART	R.TJART



MADE FROM HYDRAULIC SETTING, CLAY BASE  
 CASTABLE FORMULATED WITH A MEDIUM GRIND  
 HIGH TEMP. CALCINED AGGREGATE.  
 APPROX DENSITY 130# PER CU. FT

NOTE: ALL DRAFTS 5° EXCEPT WHERE NOTED

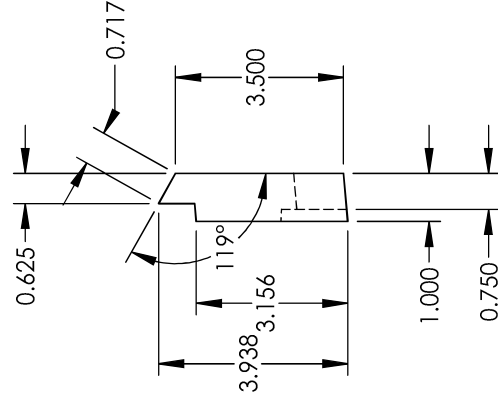
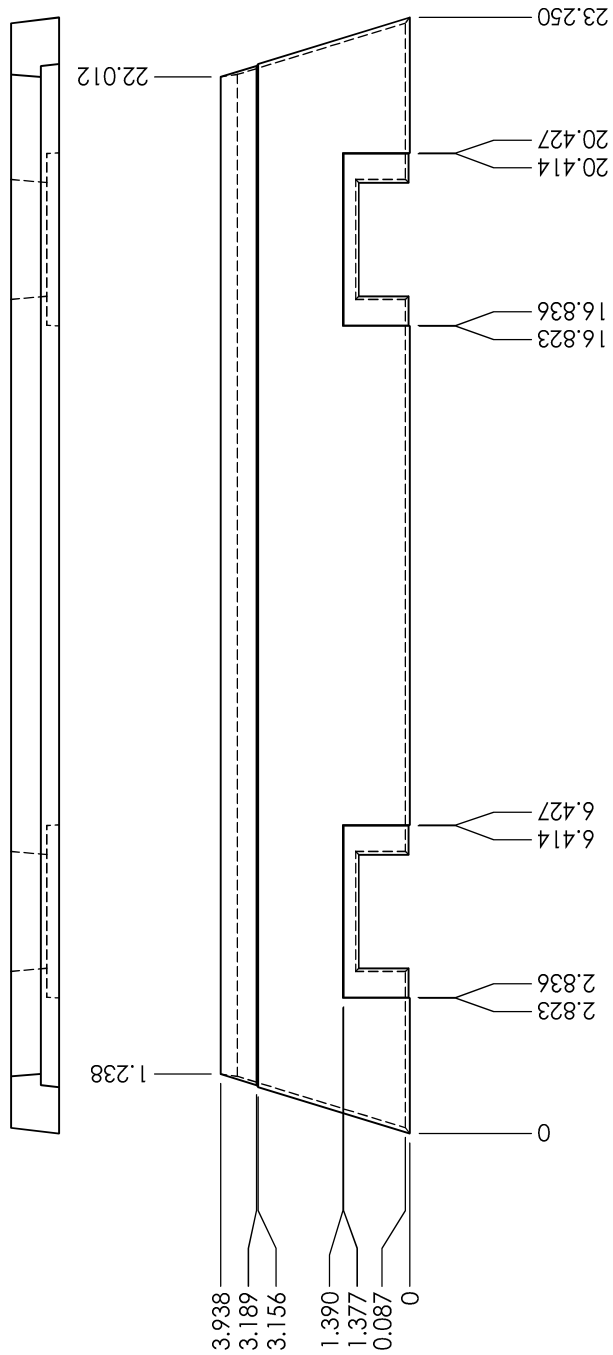
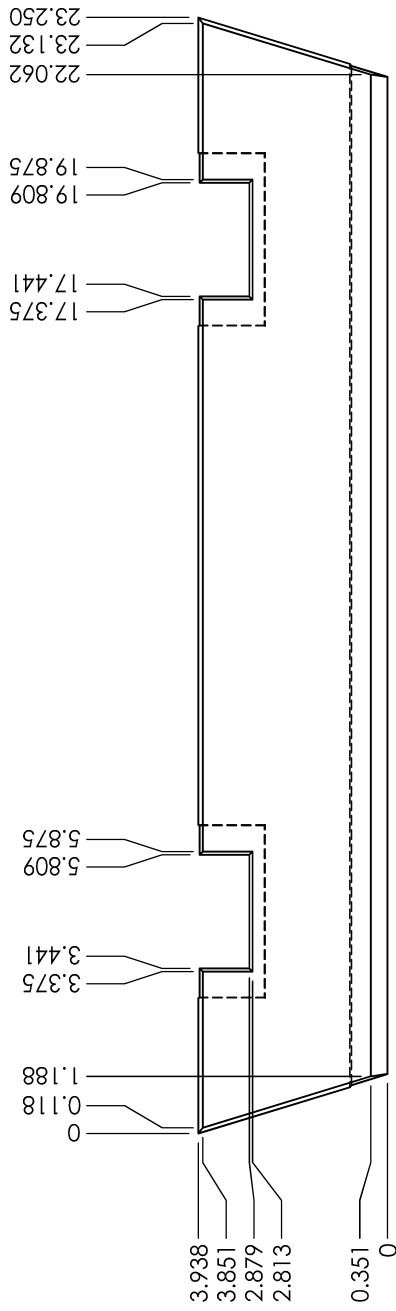

UNLESS OTHERWISE NOTED OR DEPICTED  
 ALL DIMENSIONS ARE OUTSIDE IN INCHES  
 TOLERANCES:  
 DIMENSIONS ±0.125"  
 ANGLES ±1°

TITLE: **BRICK, FRONT LEDGE**  
 MATERIAL: REFRACTORY  
 FINISH:  
 REVISION: **A** 5/31/2012 (AGR) REDESIGN PART

MODEL: EP13 DRAWING: **W090-0195**  
 5.316 LBS DRAWN BY: **A.RIGDEN**  
 SCALE: 1:4 SHEET 1 OF 1 MM/DD/YYYY: **4/30/2012**  
 CHECKED BY: **R.TJART**

MADE FROM HYDRAULIC SETTING, CLAY BASE  
 CASTABLE FORMULATED WITH A MEDIUM GRIND  
 HIGH TEMP. CALCINED AGGREGATE.  
 APPROX DENSITY 130# PER CU. FT

NOTE: ALL DRAFTS 5° EXCEPT WHERE NOTED

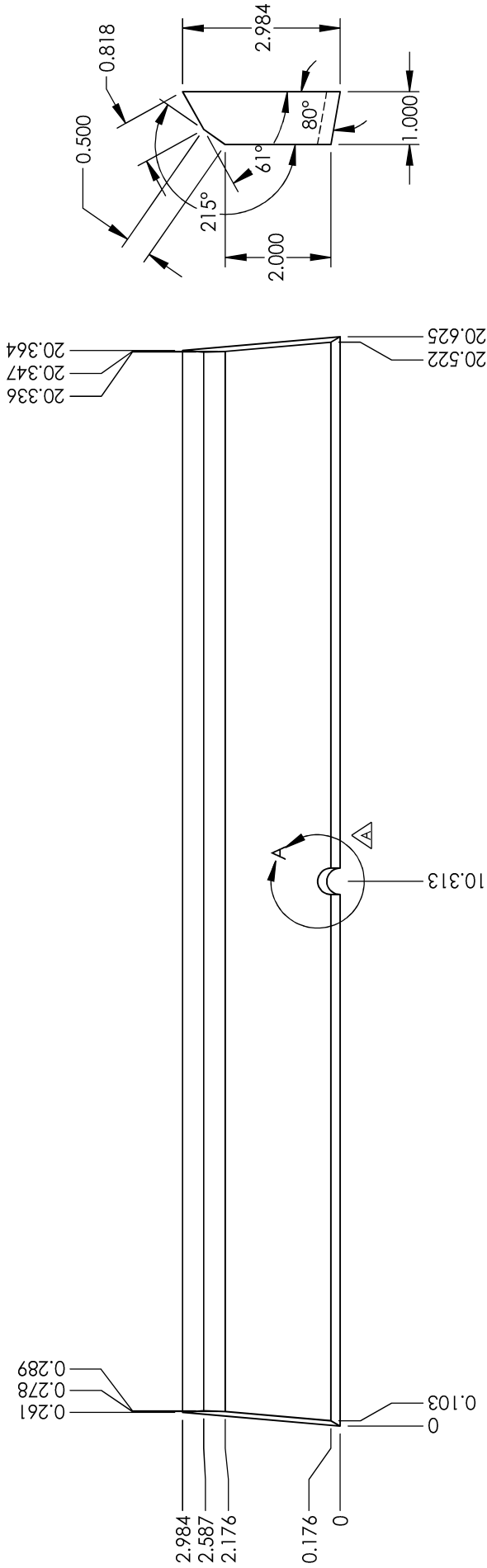

DETAIL A  
 SCALE 1:1

UNLESS OTHERWISE NOTED OR DEPICTED ALL DIMENSIONS ARE OUTSIDE IN INCHES TOLERANCES: DIMENSIONS ±0.125" ANGLES ±1°	TITLE:	BRICK, FRONT	MODEL:	EP13	DRAWING:	W090-0196
	MATERIAL:	REFRACTORY	SCALE:	1:3	DRAWN BY:	A.RIGDEN
FINISH:		REVISION:	A	5/27/2013	SHEET 1 OF 1	4/30/2012
		(AGR) ADD RELIEF			CHECKED BY:	R.TJART



NOTE: NO SHARP EDGES

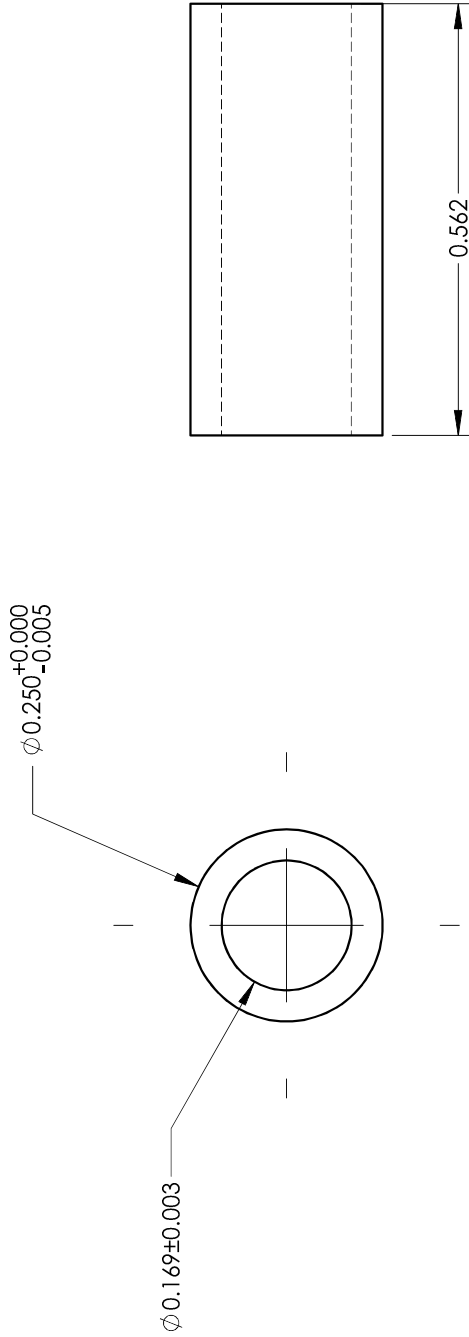

05.06.13 AR

**WOLF STEEL**<sup>TM</sup>  
**NAC**  
 Precision Steel  
 Products  
 Corporation

UNLESS OTHERWISE NOTED OR DEPICTED  
 ALL DIMENSIONS ARE OUTSIDE IN INCHES  
 ALL SURFACES ARE CONSIDERED CLASS "D"  
 REFER TO ENG-009 AND ENG-010  
 FOR SURFACE FINISH CRITERIA  
 DIMENSIONS ±0.015 RADIUS ±0.031  
 REFERENCE DIMENSIONS ±0.031 ANGLES ±2°

TITLE:	<b>BUSHING, DOOR ROLLER (EPI3C)</b>	MODEL:	EPI3C	DRAWING:	<b>W105-0019</b>
MATERIAL:	AISI 12L14 COLD DRAWN STEEL	SCALE:	4:1	DRAWN BY:	<b>A.RIGDEN</b>
FINISH:			SHEET 1 OF 1	MM/DD/YYYY:	<b>9/4/2013</b>
REVISION:	-			CHECKED BY:	R.TJART

5 4 3 2 1

D C B A

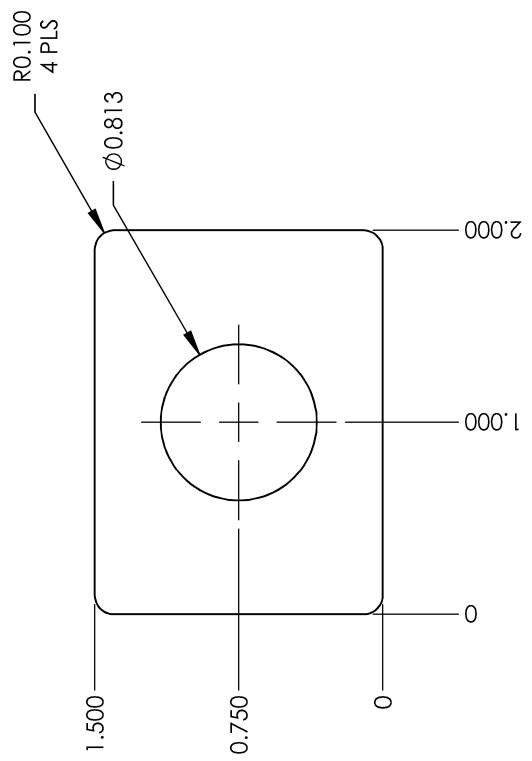

UNLESS OTHERWISE NOTED OR DEPICTED ALL DIMENSIONS ARE OUTSIDE IN INCHES ALL SURFACES ARE CONSIDERED CLASS "D" REFER TO ENG-009 FOR SURFACE FINISH CRITERIA TOLERANCES: FORMED PARTS ±0.031 REFERENCE DIMENSIONS ±0.063 BLENDED PARTS ±0.010 ANGLES ±2°	TITLE: <b>CAP, S/A ENTRANCE</b>	MODEL: EPI3-1	DRAWING: <b>W120-0100</b>
	MATERIAL: 14 GA HR P&O	THICKNESS: 0.052 LBS	ISSUE DATE: 0.075
FINISH:	CN#:	SCALE: 1:4	SHEET 1 OF 1
PROJECT LEAD: P HODGES	REV NOTE:	DRAWN BY:	UNRELEASED
REVISION: <b>P02</b>	REV DATE: <b>03/22/19</b>	CHECKED BY:	UNRELEASED



1 2 3 4 5







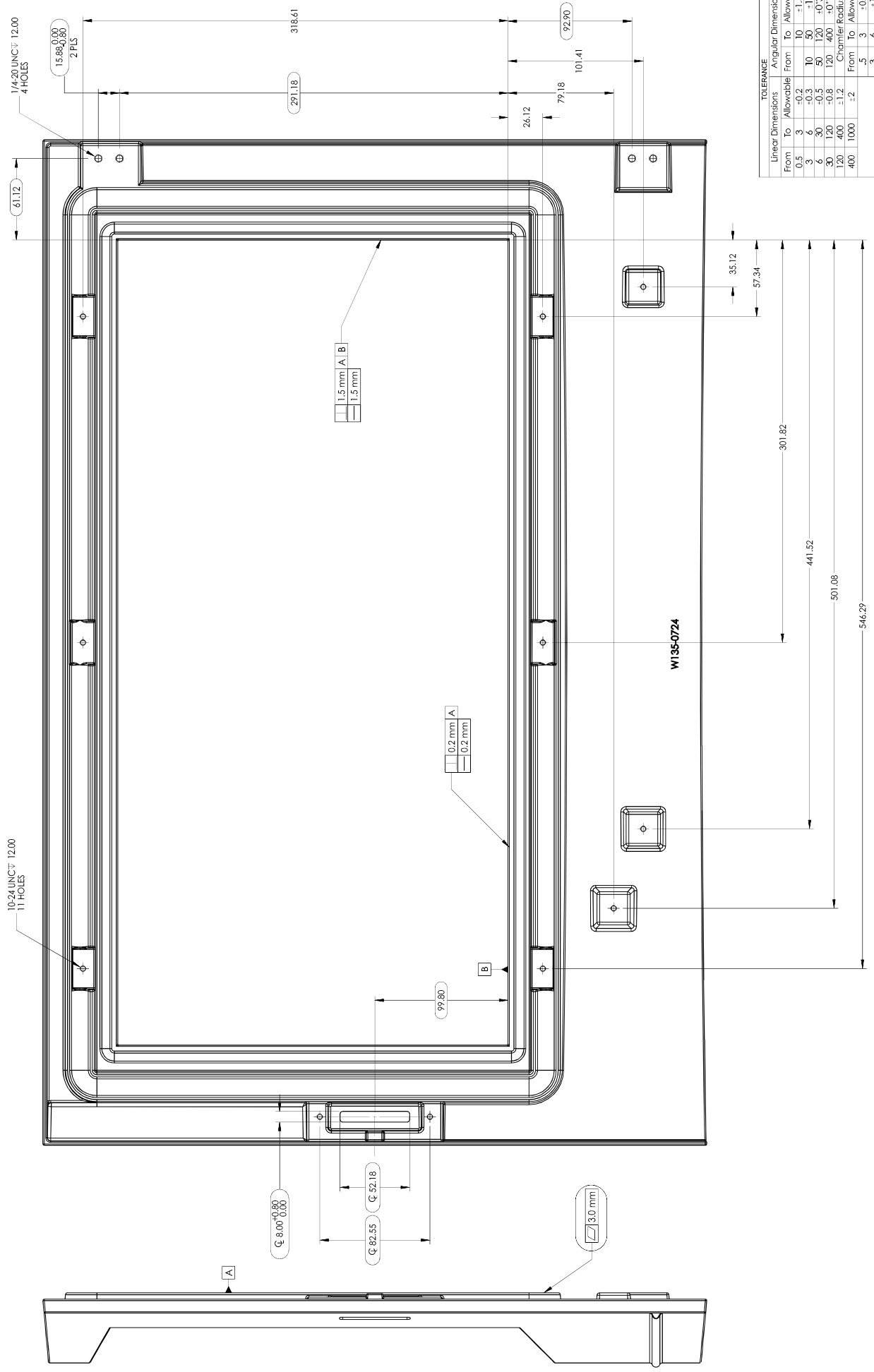

TOLERANCE		Angular Dimensions	
Linear Dimensions	From	To	Allowable
0.5	3	-0.2	10
3	6	-0.3	10
6	30	-0.5	50
30	120	-0.8	120
120	400	±1.2	400
400	1000	±2	1000
		From	To
		5	3
		3	6
		6	1
		1	2

**MODEL:** ABSTRACT ISO 2768  
**TITLE:** CASTING MAIN DOOR (CONTEMPORARY)  
**MATERIAL:** CAST IRON  
**FINISH:** STONE BRIGHT HIGH TEMP RETALIC BLACK PAINT  
**PROJECT LEAD:** P. HODGES  
**REV. DATE:** 12/04/2017  
**REV. NOTE:**  
**REVISION:** B  
**ISSUE DATE:** 05/10/17  
**SCALE:** 1:2  
**SHEET 2 OF 2**  
**DRAWN BY:** UNRELEASED  
**CHECKED BY:** UNRELEASED

NOTE:  
 1 DRAFT ANGLE 5° UNLESS OTHERWISE STATED  
 2 SYMBOL DENOTES KEY PRODUCT CHARACTERISTIC  
 3 CLASS A SURFACE FINISH BETWEEN Rg 6.3 - 12.5 (RMS 275 - 500)  
 4 USE TOLERANCE TABLE PROVIDED FOR DRAWING DIMENSIONS (DO NOT USE TOLERANCES IN TITLE BLOCK)

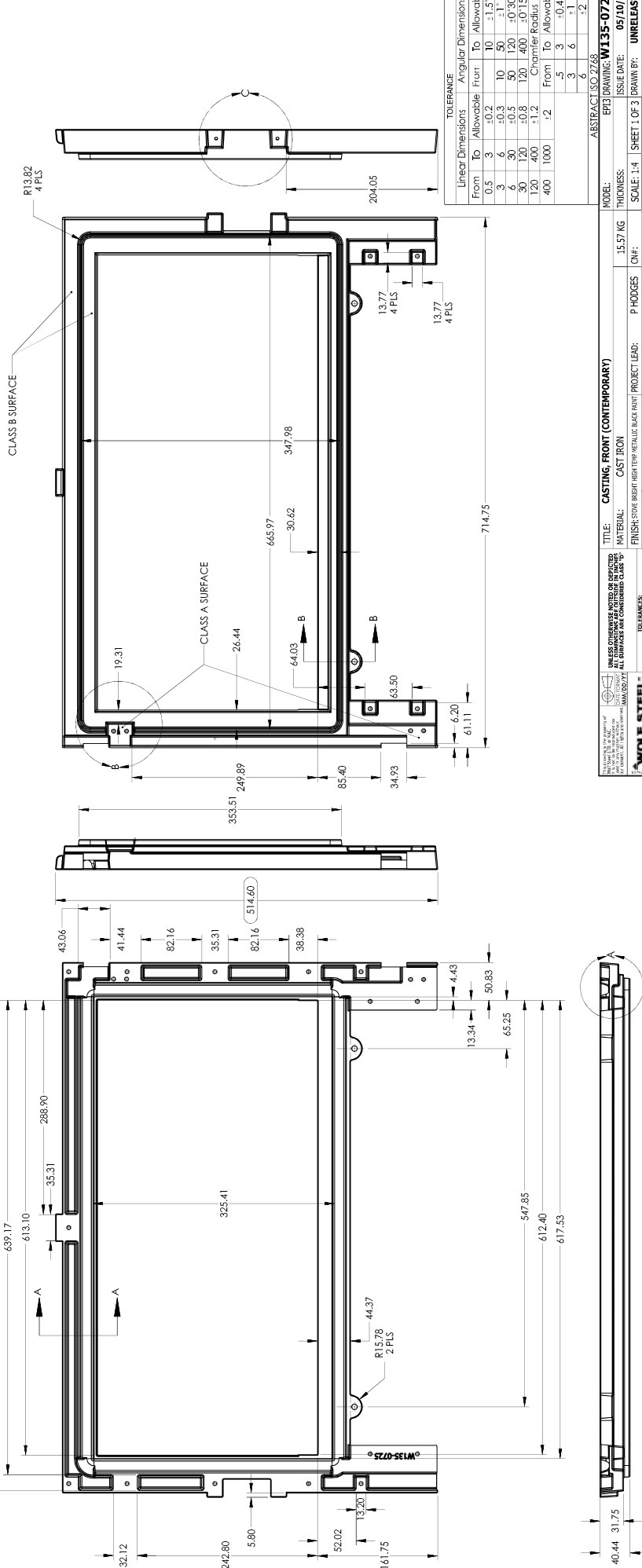
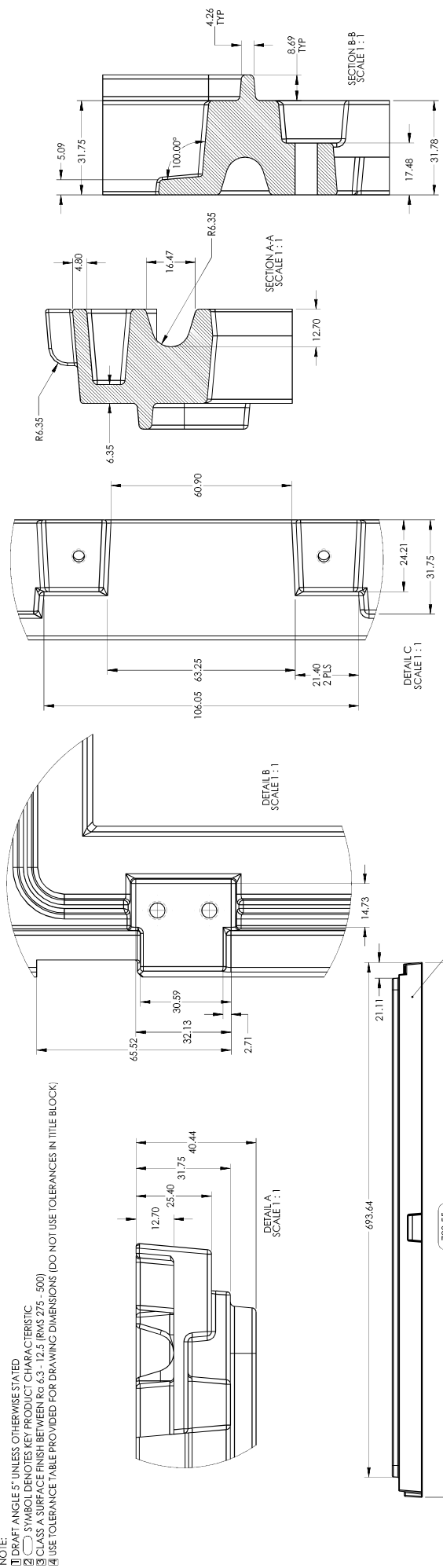

TOLERANCE		Angular Dimensions	
Linear Dimensions	From	To	Allowable
0.5	3	-0.2	10
3	6	-0.3	10
6	30	-0.5	50
30	120	-0.8	120
120	400	-1.2	400
400	1000	-1.2	1000
Chamfer Radius		From	To
		From	Allowable
		.5	3
		3	6
		6	12

**WOLF STEEL**  
 10000 WOLF STEEL DRIVE, WOLF STEEL, MISSOURI 64086  
 PHONE: (816) 338-1000 FAX: (816) 338-1001  
 WWW.WOLFSTEEL.COM

**CASTING FRONT (CONTEMPORARY)**  
 TITLE: CASTING FRONT (CONTEMPORARY)  
 MATERIAL: CAST IRON  
 FINISH: STOVE BRIGHT HIGH TEMP METALLIC BLACK PAINT  
 PROJECT LEAD: P. HODGES  
 REVISION: B (REV DATE: 12/04/17) (REV NOTE: )  
 MODEL: EPD DRAWING: W135-0725  
 THICKNESS: 15.57 KG  
 SCALE: 1:4  
 SHEET: 1 OF 3  
 DRAWN BY: UNRELEASED  
 CHECKED BY: UNRELEASED





- NOTES:
- 1] DRAFT ANGLE 5° UNLESS OTHERWISE STATED
  - 2] SYMBOL DENOTES KEY PRODUCT CHARACTERISTIC
  - 3] CLASS A SURFACE FINISH BETWEEN R<sub>a</sub> 6.3 - 12.5 (RMS 275 - 500)
  - 4] USE TOLERANCE TABLE PROVIDED FOR DRAWING DIMENSIONS (DO NOT USE TOLERANCES IN TITLE BLOCK)

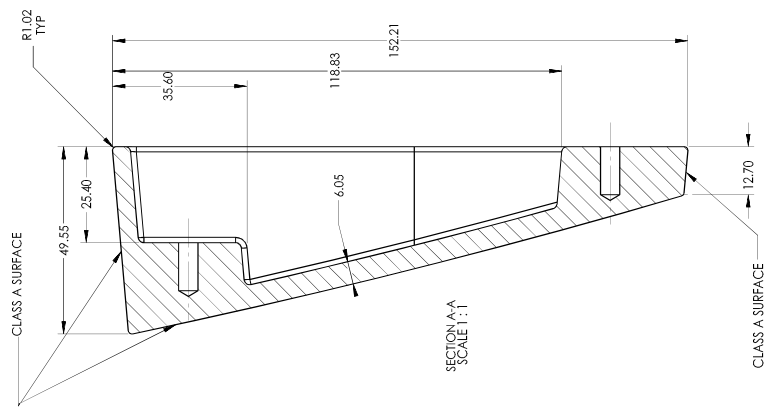
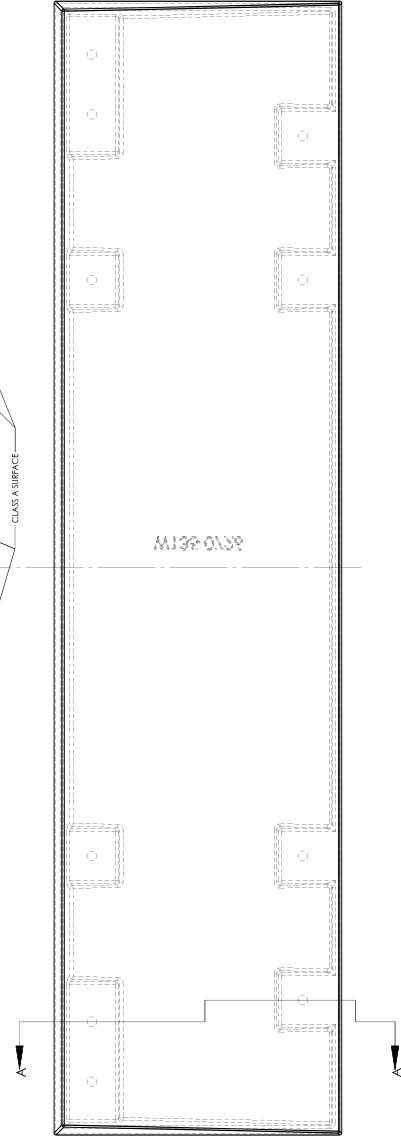
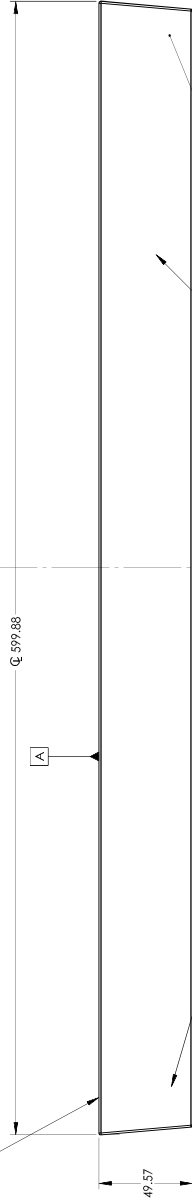
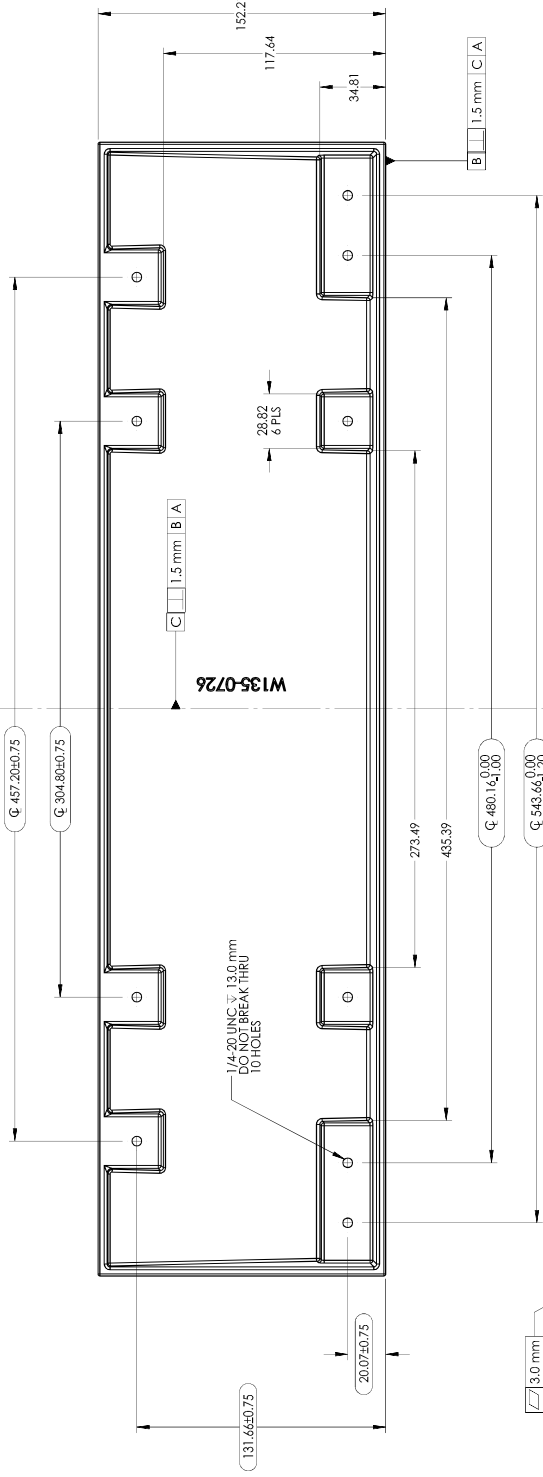

**WOLF STEEL**  
 10000 WOLF STEEL DRIVE  
 WOLF STEEL, MO 63398  
 TEL: 636-337-3300 FAX: 636-337-3301  
 WWW.WOLFSTEEL.COM

**CASTING, SIDE TRIM (CONTEMPORARY)**  
 MATERIAL: GREY CAST IRON (HT150) SUITABLE FOR PORCELAIN ENAMEL  
 FINISH: STONE BRUSH WITH VERTICAL BACKRAT PROJECT LEAD: P. HODGES ONP.  
 REVISION: C (REV DATE: 12/04/17) (REV NOTE: CORRECT WEIGHT AND NOTES)

MODEL: ABSTRACT NO. 2748  
 EPD DRAWING: W135-0726  
 THICKNESS: 05/10/17  
 SCALE: 1:2 SHEET 1 OF 1 DRAWN BY: UNRELEASED  
 CHECKED BY: UNRELEASED



NOTES:  
 1 ELIMINATE THE OLD PART NUMBER W135-0490 FROM THE MOLD AND USE THE NEW PART NUMBER W135-0727  
 2 DENOTES CRITICAL INSPECTION CRITERIA/ $\Delta$   
 3 USE TOLERANCE TABLE PROVIDED FOR DRAWING DIMENSIONS (DO NOT USE TOLERANCES IN TITLE BLOCK)  $\Delta$

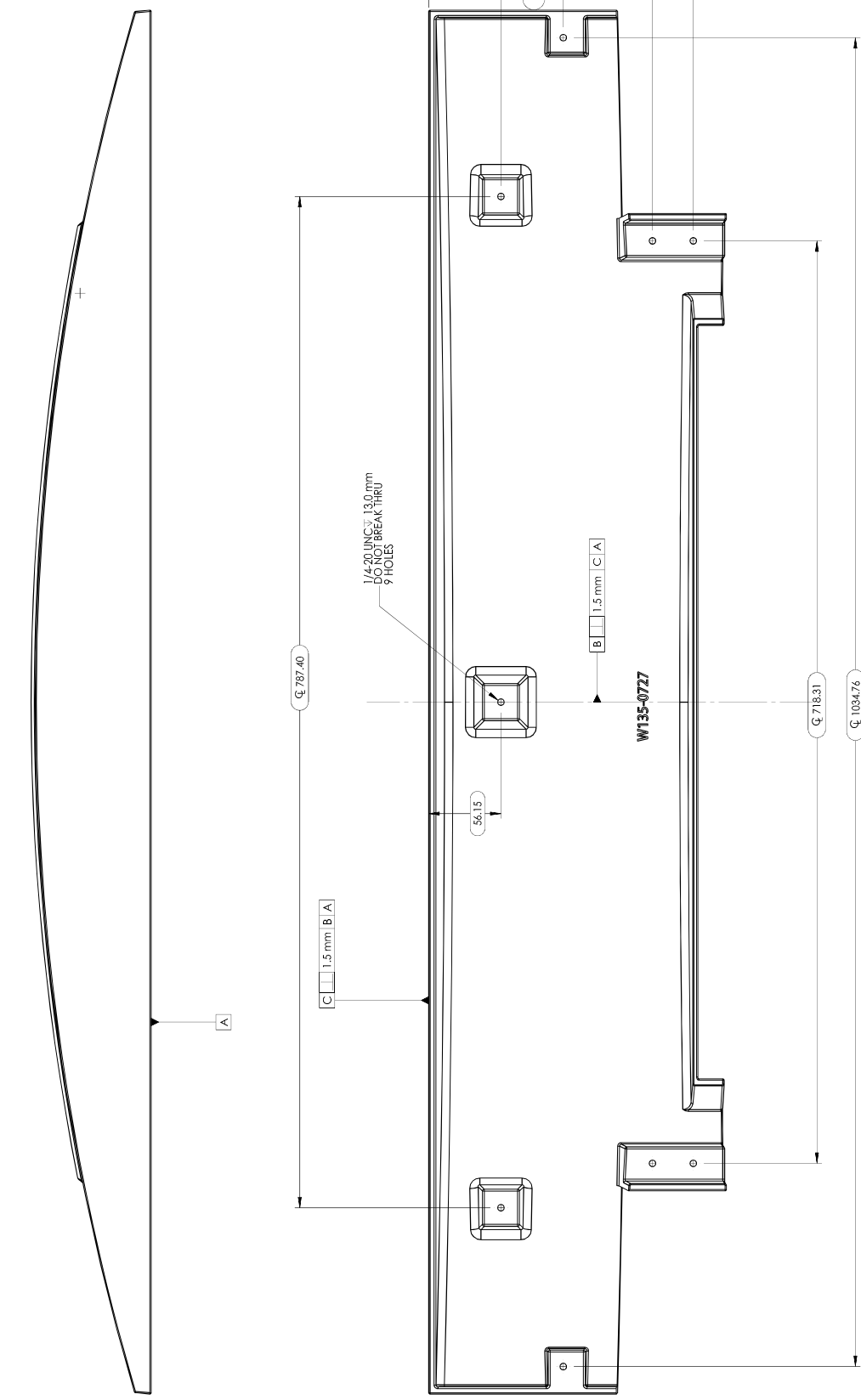

**3**  $\Delta$

Linear Dimensions		Angular Dimensions	
From	To	From	To
0.5	3	-0.2	10
3	6	-0.3	50
6	30	-0.5	120
30	100	-0.7	180
100	400	-1.0	270
400	1000	-1.2	360

ABSTRACT ISO 2768

UNLESS OTHERWISE NOTED OR SPECIFIED, ALL DIMENSIONS ARE TO BE IN MILLIMETERS AND DECIMALS THEREOF. DIMENSIONS IN PARENTHESES ARE IN INCHES AND DECIMALS THEREOF. DIMENSIONS IN PARENTHESES TAKE PRECEDENCE OVER DIMENSIONS IN MILLIMETERS.

WOLF STEEL  
 10000 WOLF STEEL DRIVE, WOLF CREEK, MISSOURI 64085-1000  
 PHONE: (816) 875-2000 FAX: (816) 875-2001  
 WWW.WOLFSTEEL.COM

TITLE: **CASTING, TOP TRIM (CONTemporary)**  
 MATERIAL: GREY CAST IRON (HT150) SUITABLE FOR PORCELAIN ENAMEL  
 FINISH: STOVE BRIGHT HIGH TEMP METALLIC BLACK PAINT  
 MODEL: 15.83 LBS  
 THICKNESS: 0.015"  
 SCALE: 1:4  
 SHEET 2 OF 2  
 DRAWN BY: UNRELEASED  
 CHECKED BY: UNRELEASED

REVISION: **C** (REV DATE: 12/4/2017) (REV NOTE: )

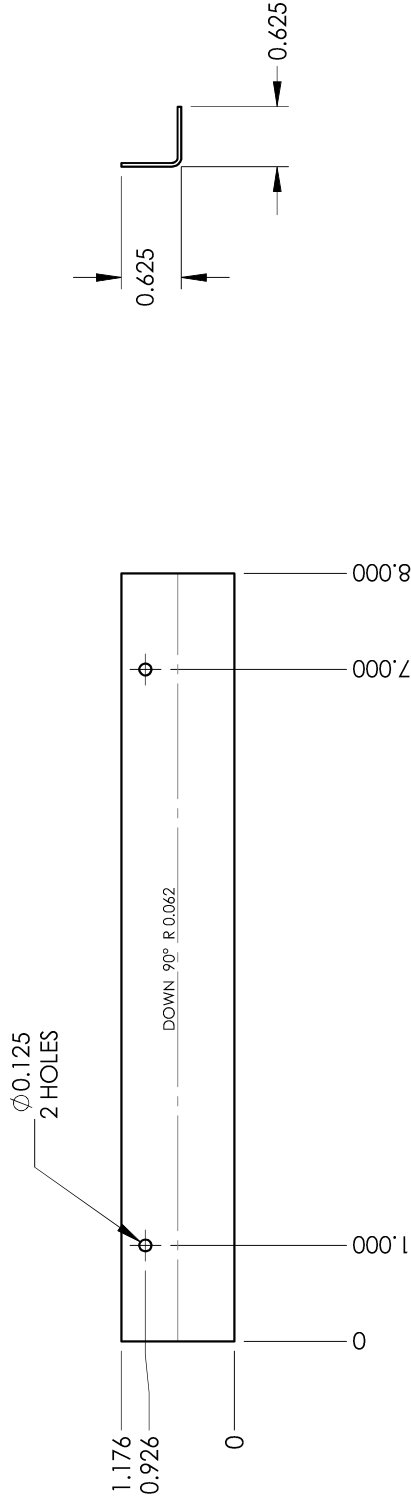

UNLESS OTHERWISE NOTED OR DEPICTED  
 ALL DIMENSIONS ARE OUTSIDE IN INCHES  
 UNLESS OTHERWISE SPECIFIED  
 WHERE APPLICABLE, FLAT IS SHOWN FINISHED SIDE UP

TOLERANCES:  
 FORMED PARTS ±0.031"  
 BEVELLED PARTS ±0.003"  
 SURFACE DIMENSIONS ±.2°  
 ANGLES



**WOLF STEEL**<sup>TM</sup>  
**NAC**  
 Product of  
 America  
 Corporation

TITLE:	CHANNEL, AIR (TOP)	MODEL:	EP13	DRAWING:	W150-0061
MATERIAL:	20 GA GALVANNEAL	THICKNESS:	0.039	DRAWN BY:	A.RIGDEN
FINISH:		SCALE:	1:2	SHEET 1 OF 1	MM/DD/YYYY: 6/13/2012
REVISION:	-			CHECKED BY:	R.TJART

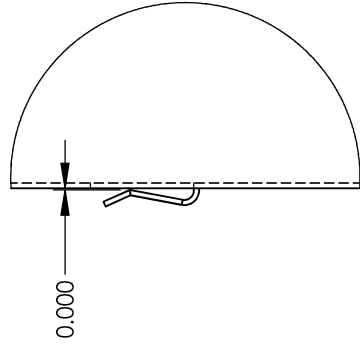

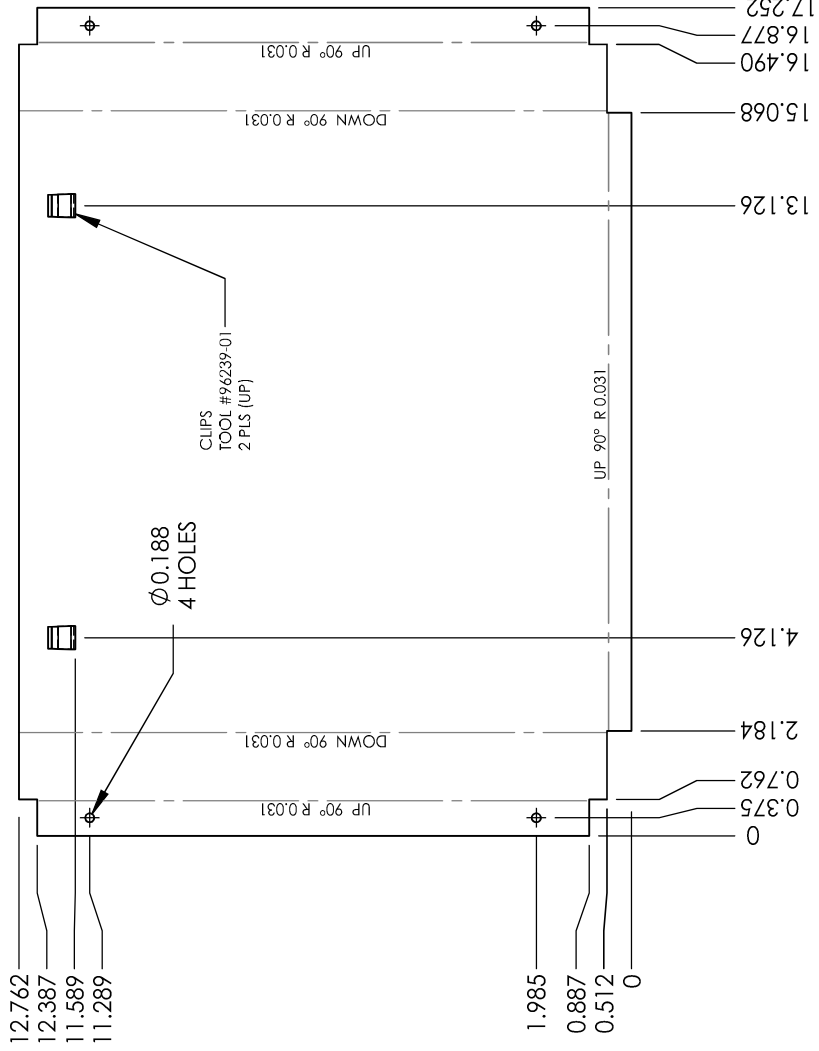
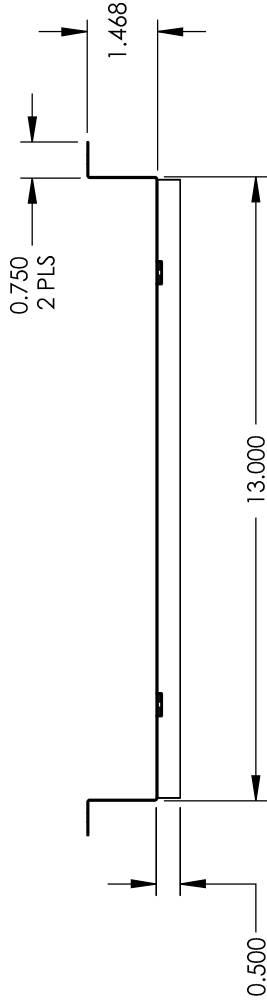

DETAIL A  
SCALE 1:1



UNLESS OTHERWISE NOTED OR DEPICTED  
ALL DIMENSIONS ARE OUTSIDE IN INCHES  
UNLESS OTHERWISE NOTED OTHERWISE  
WHERE APPLICABLE FLAT IS SHOWN FINISHED SIDE UP

TOLERANCES:  
FORMED PARTS ±0.031"  
BLANKED PARTS ±0.005"  
SURFACE DIMENSIONS ±.2°  
ANGLES



**WOLF STEEL**<sup>TM</sup>  
**NAC**  
NORTH AMERICAN  
CORPORATION

TITLE: CHANNEL, BLOWER AIR	MODEL: EP13	DRAWING: W150-0063
MATERIAL: 24 GA GALVANNEAL	THICKNESS: 0.027	DRAWN BY: A.RIGDEN
FINISH:	SCALE: 1:4	SHEET 1 OF 1
REVISION: A	1/30/2013	(AGR) ADD CLIPS
1.663 LBS	MM/DD/YYYY: 6/13/2012	CHECKED BY: R.TJART

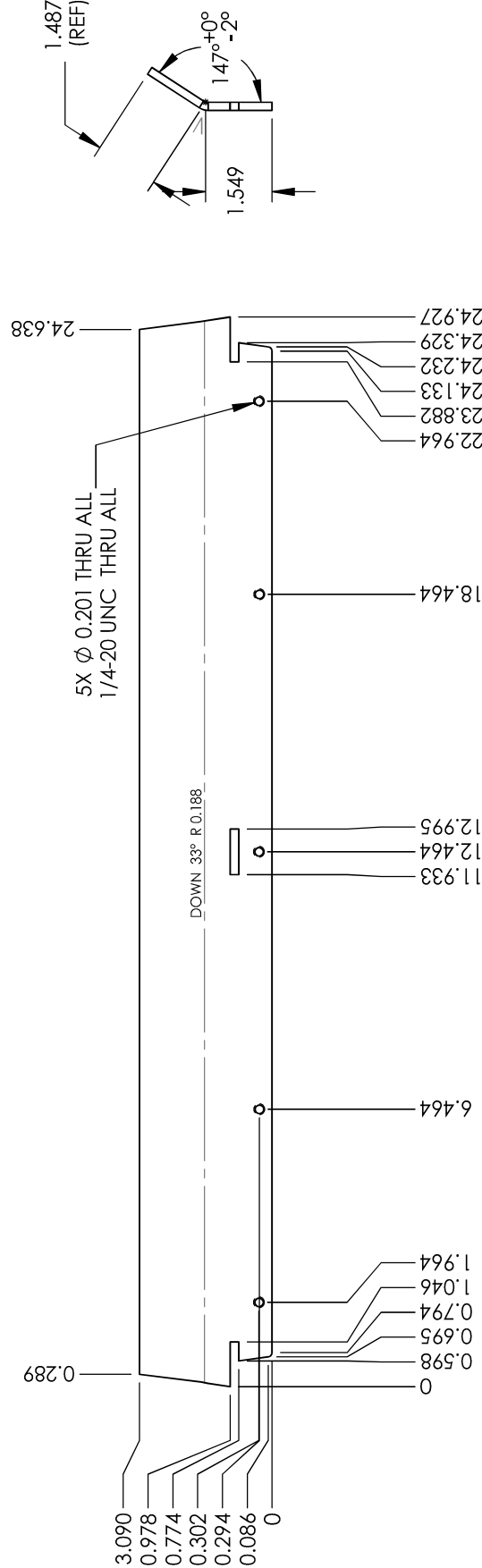
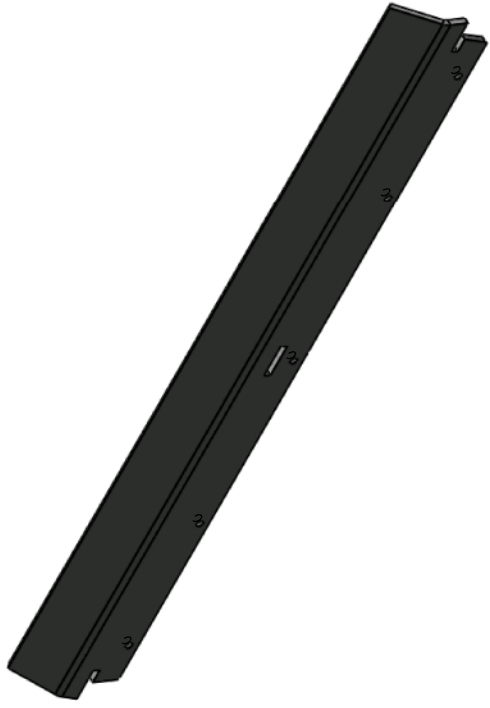

<p>120617 BY G.S.</p> <p><b>WOLF STEEL™</b></p> <p>This drawing is the property of Wolf Steel Ltd. or NCC. It is not to be used in any manner without our consent. All rights are reserved.</p> <p>DATE FOR WAT MM/DD/YY</p>	<p><b>TOLERANCES:</b> UNLESS OTHERWISE NOTED OR DEPICTED ALL DIMENSIONS ARE OUTSIDE IN INCHES ALL SURFACES ARE CONSIDERED CLASS "D"</p> <p>DIMENSIONS ±0.062 REFERENCE DIMENSIONS ±0.125</p> <p>RADIUS ±0.062 ANGLES ±2</p>	<p><b>TITLE:</b> CHANNEL, AIR WASH</p> <p><b>MATERIAL:</b> 3/16 HR P&amp;O</p> <p><b>FINISH:</b></p>	<p><b>MODEL:</b> EP13-1</p> <p><b>THICKNESS:</b> 0.188</p> <p><b>SCALE:</b> 1:4</p>	<p><b>DRAWING:</b> W150-0064</p> <p><b>ISSUE DATE:</b> 06/13/12</p> <p><b>SHEET 1 OF 1</b></p>
	<p><b>PROJECT LEAD:</b> P HODGES</p> <p><b>REV DATE:</b> 6/19/2018</p> <p><b>REV NOTE:</b></p>	<p><b>3.950 LBS</b></p> <p><b>CN#:</b></p>	<p><b>CHECKED BY:</b> UNRELEASED</p>	<p><b>DRAWN BY:</b> UNRELEASED</p>

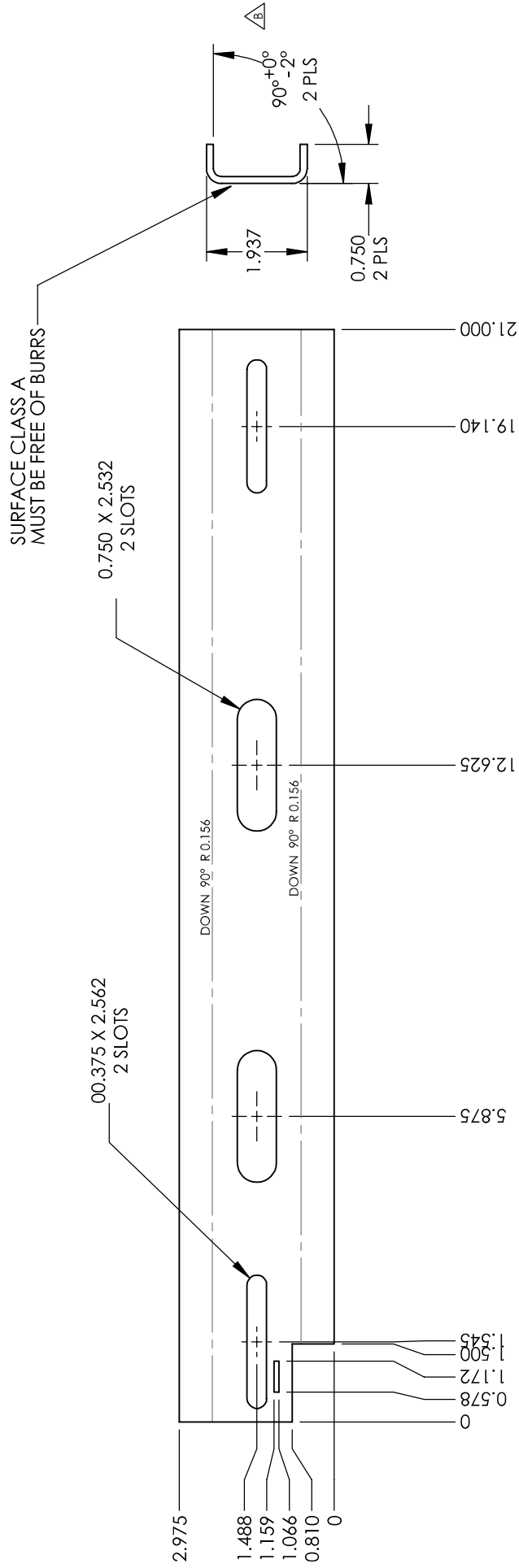

<p>UNLESS OTHERWISE NOTED OR DEPICTED ALL DIMENSIONS ARE OUTSIDE IN INCHES</p> <p>TOLERANCES: WHERE APPLICABLE, FLAT IS SHOWN FINISHED SIDE UP</p> <p>FORMED PARTS ±0.031" BLANKED PARTS ±0.010" REFERENCE DIMENSIONS ±0.063" ANGLES ±2°</p>		<p>TITLE: CONTROL, AIR</p> <p>MATERIAL: 10 GA SS 304-2B</p> <p>FINISH:</p> <p>REVISION: B 05/24/13 (AGR) ADD DIM&amp;TOLERANCE</p>	<p>MODEL: EPT3</p> <p>THICKNESS: 0.135</p> <p>SCALE: 1:3</p>	<p>DRAWING: W190-0043</p> <p>DRAWN BY: A.RIGDEN</p> <p>MM/DD/YYYY: 06/13/12</p> <p>CHECKED BY: R.TJART</p>
--	--	--	--	--



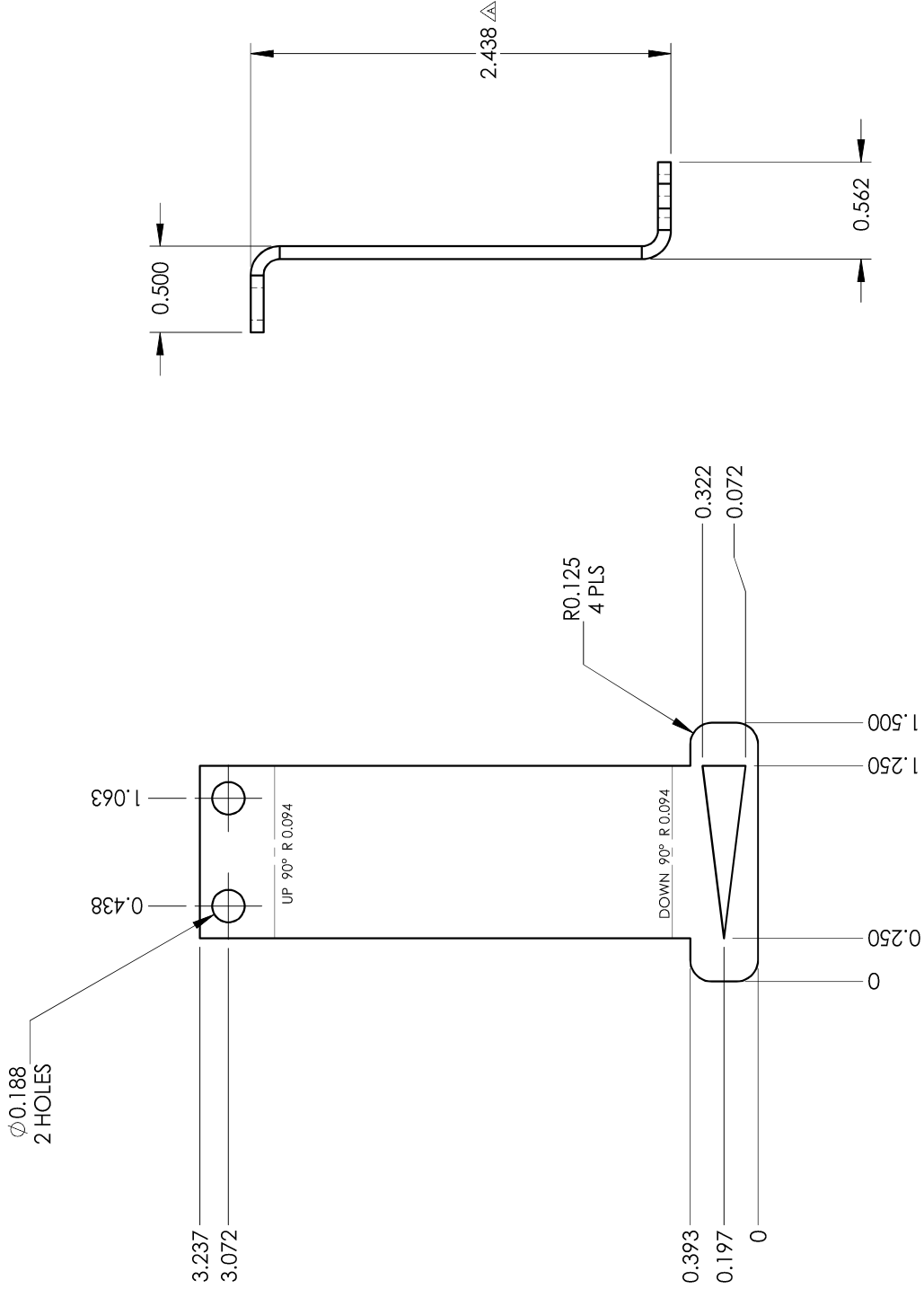

UNLESS OTHERWISE NOTED OR DEPICTED  
 ALL DIMENSIONS ARE OUTSIDE IN INCHES  
 UNLESS OTHERWISE SPECIFIED  
 WHERE APPLICABLE FLAT IS SHOWN FINISHED SIDE UP

**TOLERANCES:**  
 FORMED PARTS ±0.031"  
 BEVELLED PARTS ±0.009"  
 SURFACE FINISH DIMENSIONS ±2°  
 ANGLES

The drawing is the property of Wolf Steel LTD., or NAC. It is to be used only for the project and order number for which it was prepared. All rights are reserved.

**WOLF STEEL<sup>TM</sup>**  
**NAC** Manufactured in America  
 C-10710-0011-01

TITLE:	<b>CONTROL, AIR INDICATOR</b>	MODEL:	EPI3T	DRAWING:	<b>W190-0052</b>
MATERIAL:	14 GA HR P&O	THICKNESS:	0.075	DRAWN BY:	<b>A.RIGDEN</b>
FINISH:		SCALE:	1:1	MM/DD/YYYY:	<b>6/13/2012</b>
REVISION:	<b>A</b>	(AGR) ADD MATERIAL		SHEET 1 OF 1	CHECKED BY: <b>R.TJART</b>

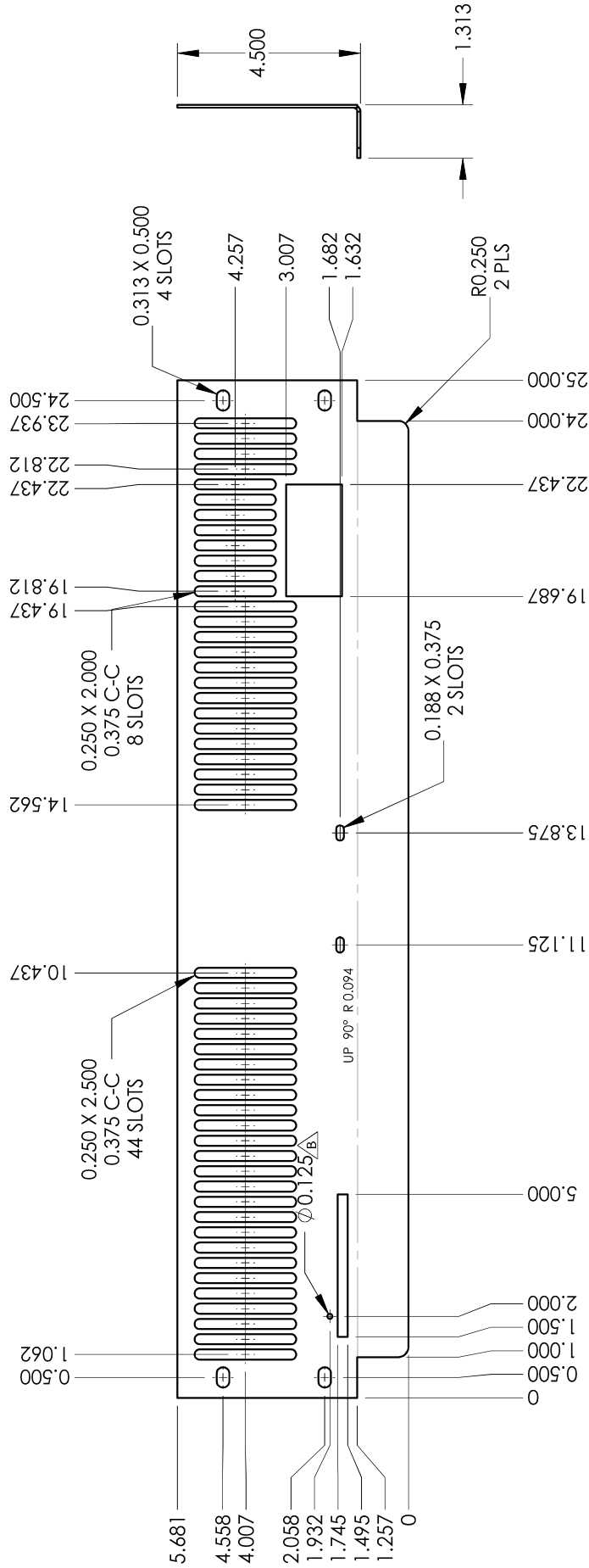

UNLESS OTHERWISE NOTED OR DEPICTED, ALL DIMENSIONS ARE TO BE INTERPRETED TO CLASS "B" UNLESS OTHERWISE SPECIFIED. ALL SURFACES ARE CONSIDERED CLASS "D". REFER TO ENG-009 AND ENG-010 FOR SURFACE FINISH CRITERIA.	TITLE:	COVER BLOWER	MODEL:	EPI3	DRAWING:	W200-0356
	MATERIAL:	14 GA HR P&O	THICKNESS:	0.075	DRAWN BY:	A.RIGDEN
FINISH:		WEIGHT:	2.184 LBS	SCALE:	1:4	SHEET 1 OF 1
REVISION:	B	DATE:	5/16/2013	CHECKED BY:	R.TJART	
TOLERANCES: FORMED PARTS ±0.031 BLANKED PARTS ±0.010 REFERENCE DIMENSIONS ±0.063 ANGLES ±2						



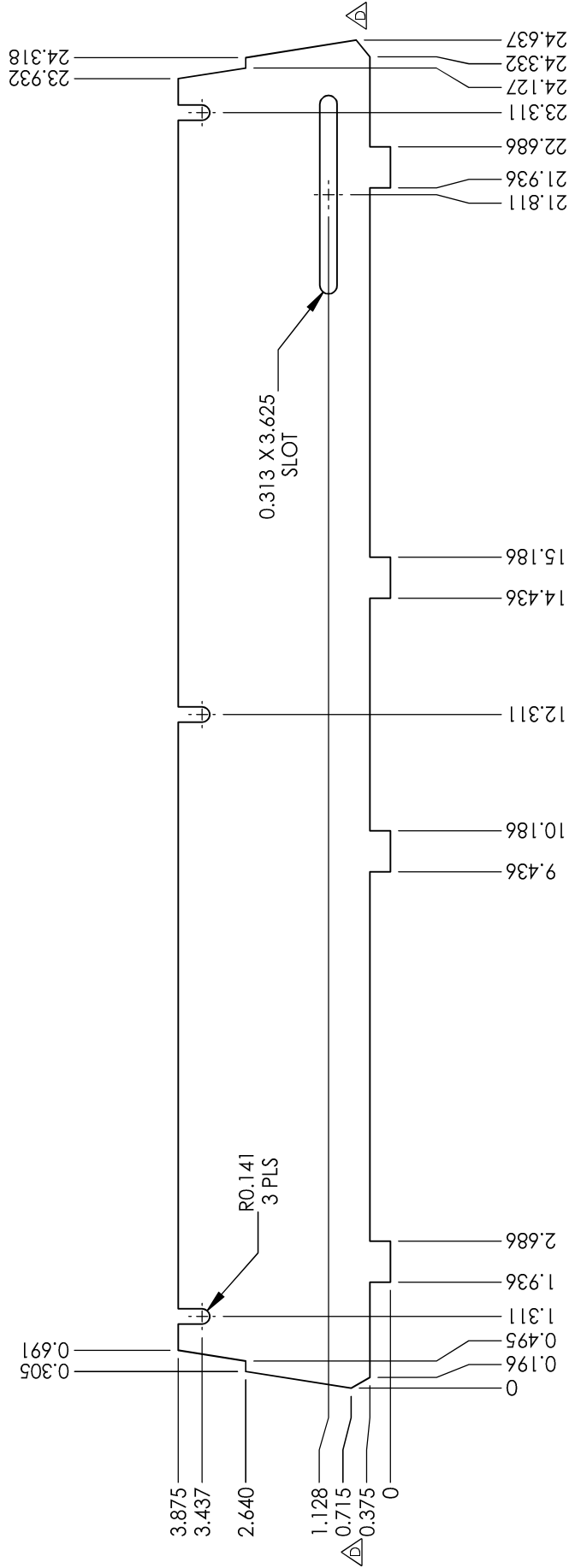

UNLESS OTHERWISE NOTED OR DEPICTED ALL DIMENSIONS ARE OUTSIDE IN INCHES UNLESS OTHERWISE NOTED WHERE APPLICABLE, FLAT IS SHOWN FINISHED SIDE UP		TITLE: <b>COVER, AIR CONTROL</b>		MODEL: EP13		DRAWING: <b>W200-0411</b>	
TOLERANCES: FORMED PARTS ±0.031" BEVELLED PARTS ±0.003" SURFACE DIMENSIONS ±.2°		MATERIAL: 18 GA ALUMINIZED		THICKNESS: 0.051		DRAWN BY: <b>A.RIGDEN</b>	
FINISH:		WEIGHT: 1.207 LBS		SCALE: 1:3		SHEET 1 OF 1	
REVISION: <b>D</b>		DATE: <b>9/27/2013</b>		CHECKED BY:		DATE: <b>6/13/2012</b>	
(AGR) ADD RELIEFS		(AGR) ADD RELIEFS		(AGR) ADD RELIEFS		(AGR) ADD RELIEFS	



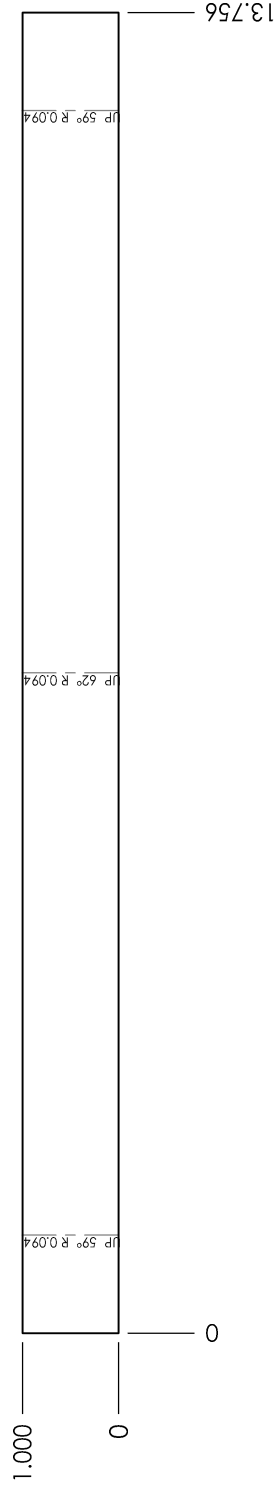
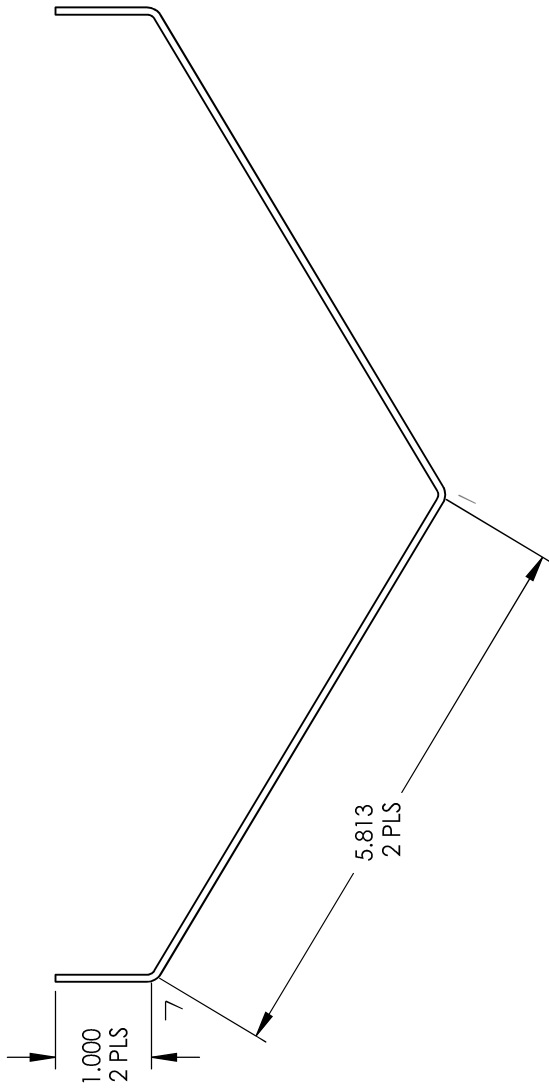

<p>UNLESS OTHERWISE NOTED OR DEPICTED ALL DIMENSIONS ARE OUTSIDE IN INCHES</p> <p>WHERE APPLICABLE, FLAT IS SHOWN FINISHED SIDE UP</p> <p>FORMED PARTS ±0.031" BLANKED PARTS ±0.010" REFERENCE DIMENSIONS ±0.063" ANGLES ±2°</p>		<p>TOLERANCES:</p>	<p>TITLE: DEFLECTOR, BLOWER AIR</p>	<p>MODEL: EP13</p>	<p>DRAWING: W215-0158</p>
<p>MATERIAL: 14 GA HR P&amp;O</p>	<p>0.287 LBS</p>	<p>THICKNESS: 0.074</p>	<p>FINISH:</p>	<p>SCALE: 1:2</p>	<p>DRAWN BY: A.RIGDEN</p>
<p>REVISION: -</p>	<p>SHEET 1 OF 1</p>	<p>SHEET 1 OF 1</p>	<p>CHECKED BY: R.TJART</p>	<p>DATE: 6/13/2012</p>	<p>DATE: 6/13/2012</p>



This drawing is the property of Wolf Steel LTD. or NAC. It is to be used only for the project and order number for which it was prepared. All rights are reserved.

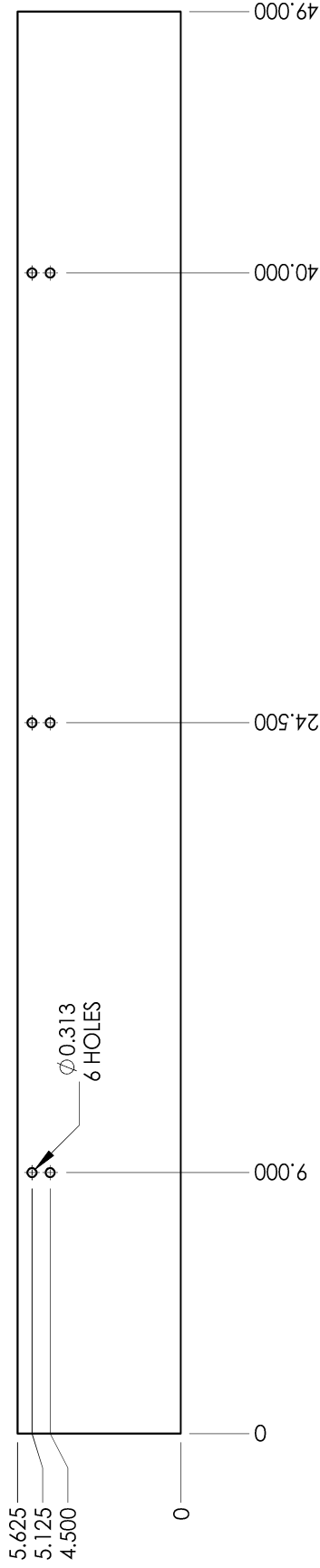

UNLESS OTHERWISE NOTED OR DEPICTED  
 ALL DIMENSIONS ARE OUTSIDE IN INCHES  
 WHERE APPLICABLE. FINISH IS SHOWN FINISHED SIDE UP

TOLERANCES:  
 FORMED PARTS ±0.031"  
 BURNED PARTS ±0.063"  
 SURFACE DIMENSIONS ±.2°  
 ANGLES

The drawing is the property of Wolf Steel Ltd., or NAC. It is to be used only for the project and location specified hereon. All rights are reserved.

**WOLF STEEL**<sup>TM</sup>  
**NAC**  
 Engineered in  
 Canada  
 Corporation

TITLE:	FLASHING, TOP	MODEL:	EP13	DRAWING:	W263-0132
MATERIAL:	24 GA GALVANNEAL	THICKNESS:	0.027	DRAWN BY:	A.RIGDEN
FINISH:		SCALE:	1:6	SHEET 1 OF 1	MM/DD/YYYY: 7/5/2012
REVISION:	~	CHECKED BY:			R.TJART



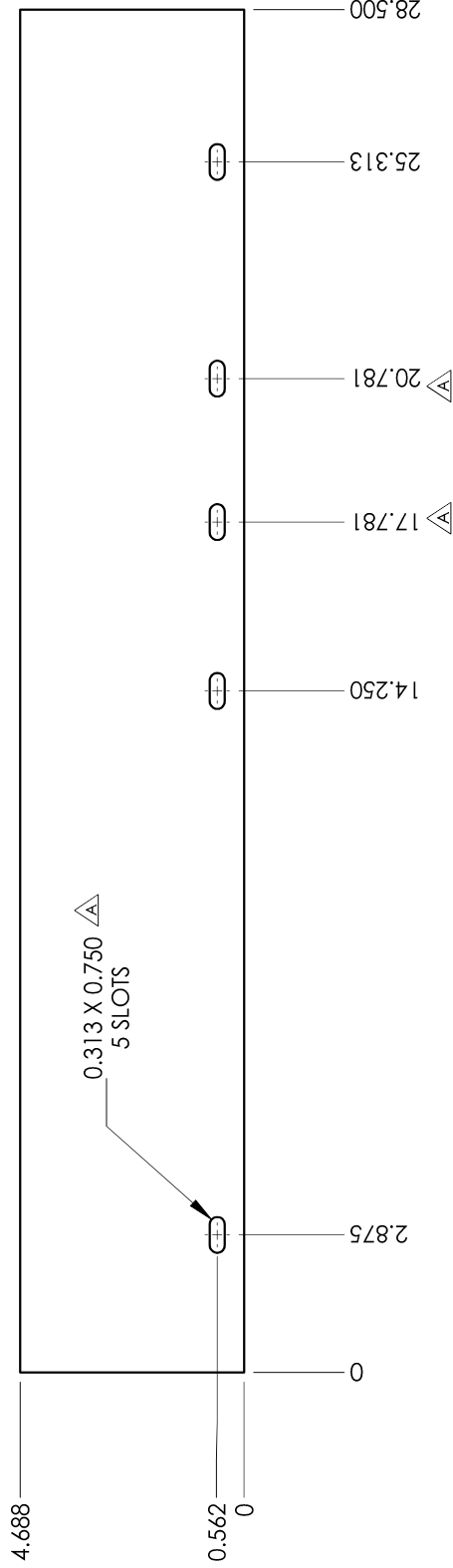

UNLESS OTHERWISE NOTED OR DEPICTED ALL DIMENSIONS ARE OUTSIDE IN INCHES SURFACES UNLESS SHOWN OTHERWISE WHERE APPLICABLE, FINISH IS SHOWN FINISHED SIDE UP		TITLE: <b>FLASHING, SIDES</b>		MODEL: EP13		DRAWING: <b>W263-0133</b>	
TOLERANCES: FORMED PARTS: ±0.031" BURNED PARTS: ±0.063" SURFACE DIMENSIONS: ±0.063" ANGLES: ±2°		MATERIAL: 24 GA GALVANNEAL		THICKNESS: 1.017 LBS		DRAWN BY: <b>A.RIGDEN</b>	
FINISH:		REVISION: <b>A</b>		SCALE: 1:4		CHECKED BY: <b>R.TJART</b>	
(AGR) ADD SLOT/MOVE SLOT		5/27/2013		SHEET 1 OF 1		7/5/2012	

**WOLF STEEL**<sup>TM</sup>  
**NAC**  
 NORTH AMERICAN  
 CORRUGATED  
 COMPANY

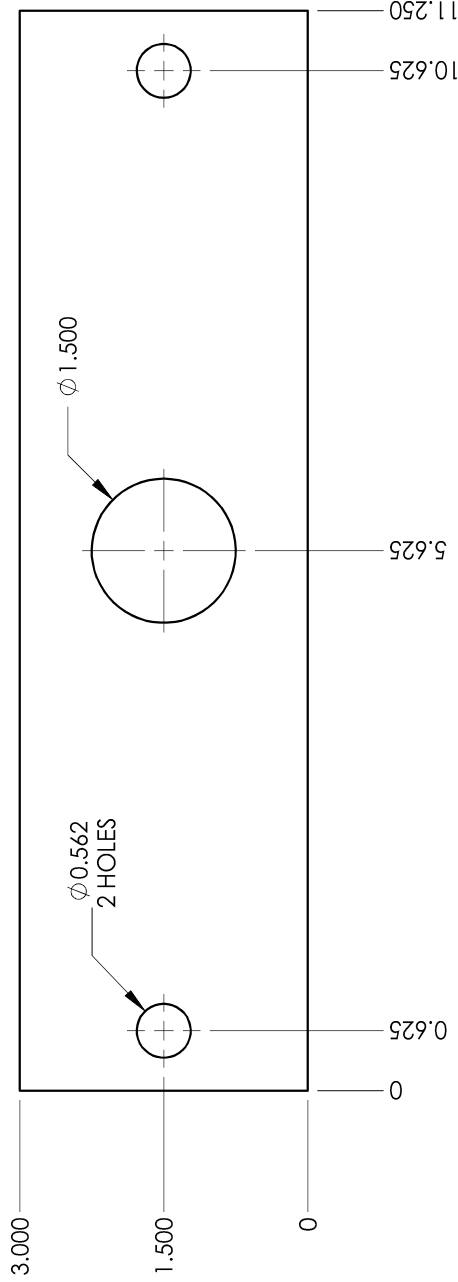

This drawing is the property of Wolf Steel LTD., or NAC. It is to be used only for the project and for the customer named herein. All rights are reserved.

UNLESS OTHERWISE NOTED OR DEPICTED  
 ALL DIMENSIONS ARE OUTSIDE IN INCHES  
 ALL SURFACES ARE CONSIDERED CLASS 10  
**TOLERANCES:**  
 DIMENSIONS ±0.003"  
 REFERENCE DIMENSIONS ±0.125"  
 ANGLES ±2°

**TITLE:** GASKET, S/A CHAMBER  
**MATERIAL:** 1/8" CERAMIC FIBRE PAPER (2150°F)  
**FINISH:**  
**REVISION:** -

**MODEL:** EP13  
**DRAWING:** W290-0215  
**DRAWN BY:** A.RIGDEN  
**SCALE:** 1:2 SHEET 1 OF 1  
**CHECKED BY:** R.TJART  
**DATE:** 6/13/2012

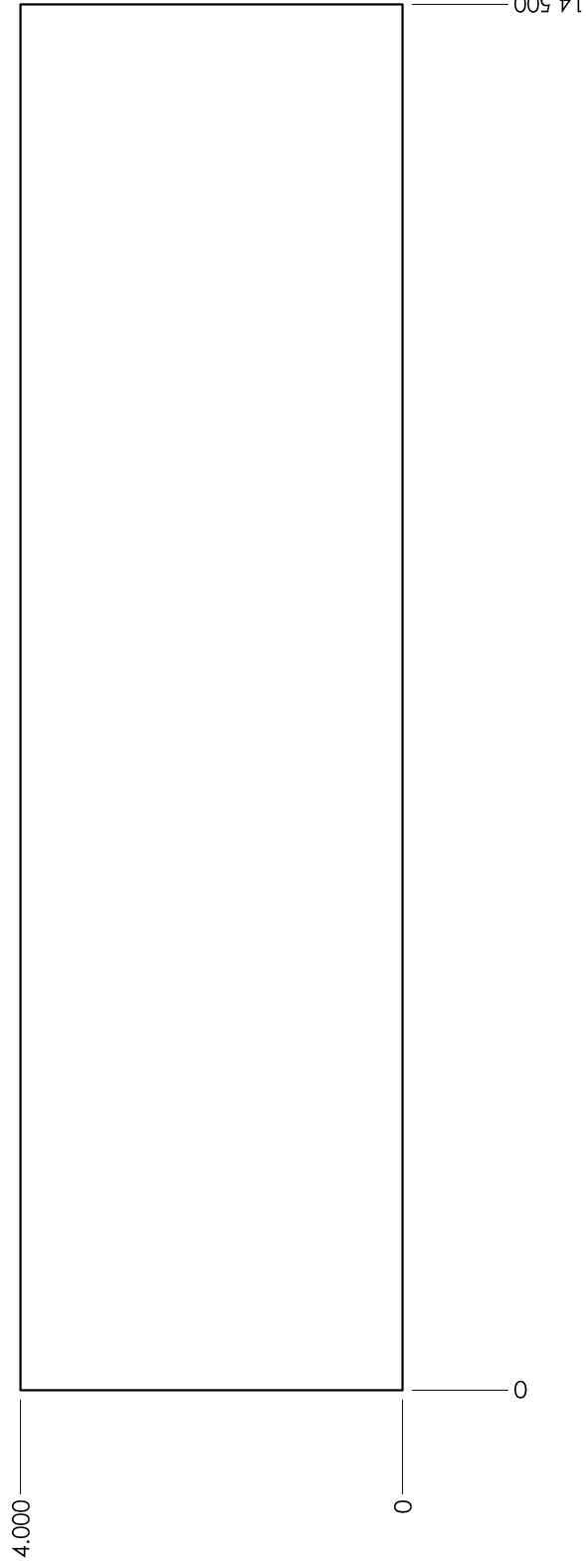

This drawing is the property of Wolf Steel Ltd. or NAC. It is to be used only for the project and without our consent. All rights are reserved.

**WOLF STEEL**<sup>TM</sup>  
**NAC**  
 Manufacturing  
 Corporation

UNLESS OTHERWISE NOTED OR DEPICTED, ALL DIMENSIONS ARE OUTSIDE UNLESS OTHERWISE SPECIFIED. ALL SURFACES ARE CONSIDERED CLASS 'D' REFER TO ENG-009 AND ENG-010 FOR SURFACE FINISH CRITERIA

TOLERANCES:  
 DIMENSIONS: +0.063 RADIUS ± 0.031  
 REFERENCE DIMENSIONS: ± 0.125 ANGLES ± 2

TITLE: **GASKET, BLOWER VIBRATION DAMPER**

MATERIAL: 1/8" FIBERGLASS PAPER

FINISH:

REVISION: ~

MODEL: EP13

SCALE: 1:2

SHEET 1 OF 1

DRAWING: W290-0229

DRAWN BY: A.RIGDEN

MM/DD/YYYY: 2/25/2013

CHECKED BY: R.TJART



- NOTES: 1. MUST BE USED IN CONJUNCTION WITH WOLF STEEL ENGINEERING APPROVED 3D MODEL  
 2. SHEET METAL INSERT MUST BE COMPLETELY FREE OF BURRS  
 3. HANDLE BARREL MATERIAL, BLACK, NYLON 66 PA66, AND MUST BE CAPABLE OF CONTINUOUS OPERATION AT 230°C  
 4. HANDLE BARREL MUST HAVE FLASH REMOVED/POLISHED

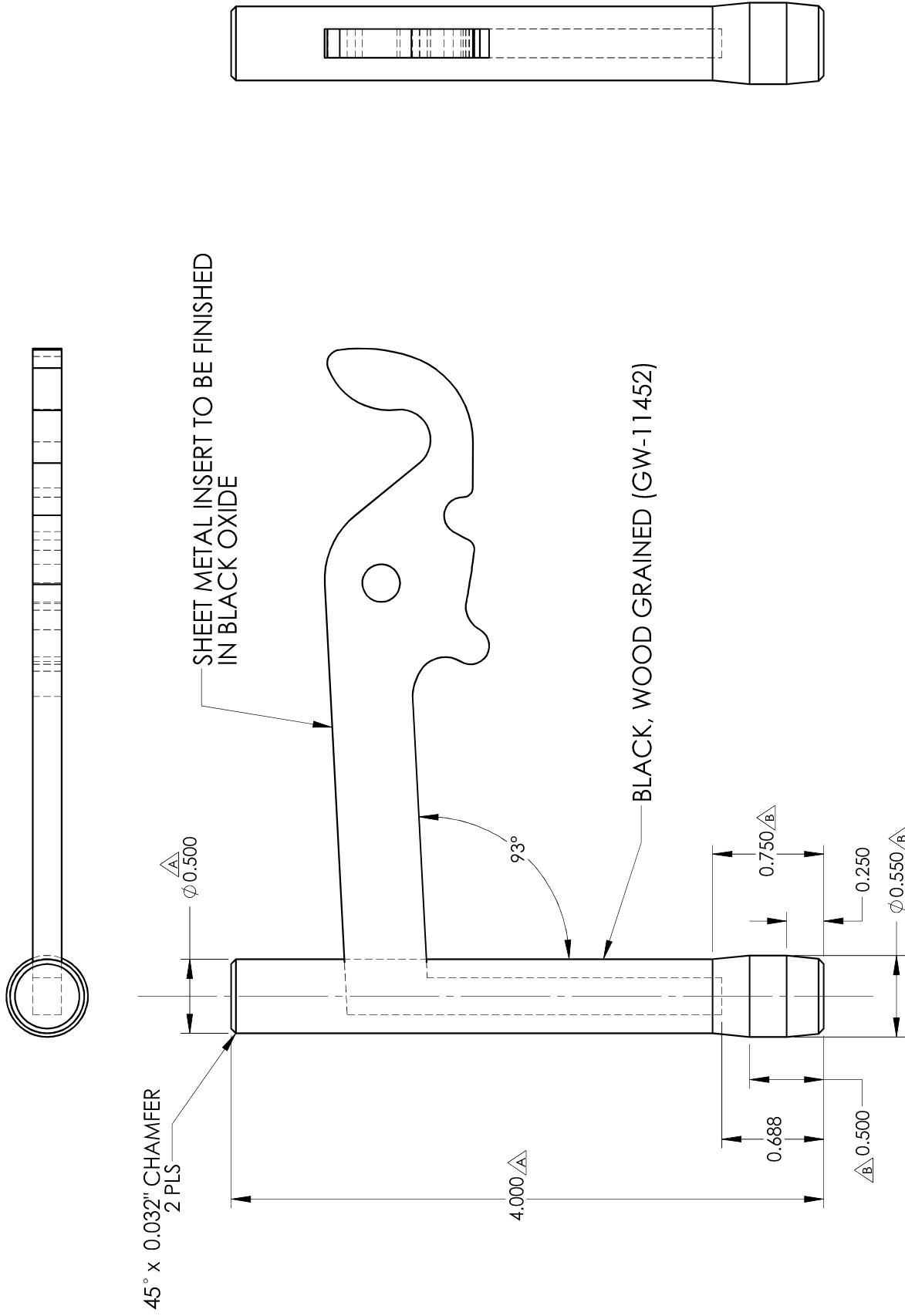

UNLESS OTHERWISE NOTED OR DEPICTED ALL DIMENSIONS ARE OUTSIDE IN INCHES ALL SURFACES ARE CONSIDERED CLASS "B"		TITLE:	HANDLE, EP13 DOOR	MODEL:	EP13	DRAWING:	W325-0077
DIMENSIONS REFERENCE DIMENSIONS ANGLES		MATERIAL:			0.210 LBS	DRAWN BY:	A.RIGDEN
TOLERANCES: ±0.015" ±0.031" ±.2°		FINISH:		SCALE:	1:1	MM/DD/YYYY:	6/13/2012
		REVISION:	B	12/12/2012	(JMD) REVISED FOR BETTER FIT	CHECKED BY:	R.TJART



NOTES: 1. MUST BE USED IN CONJUNCTION WITH WOLF STEEL ENGINEERING APPROVED 3D MODEL  
 2. PART MUST BE COMPLETELY FREE OF BURRS

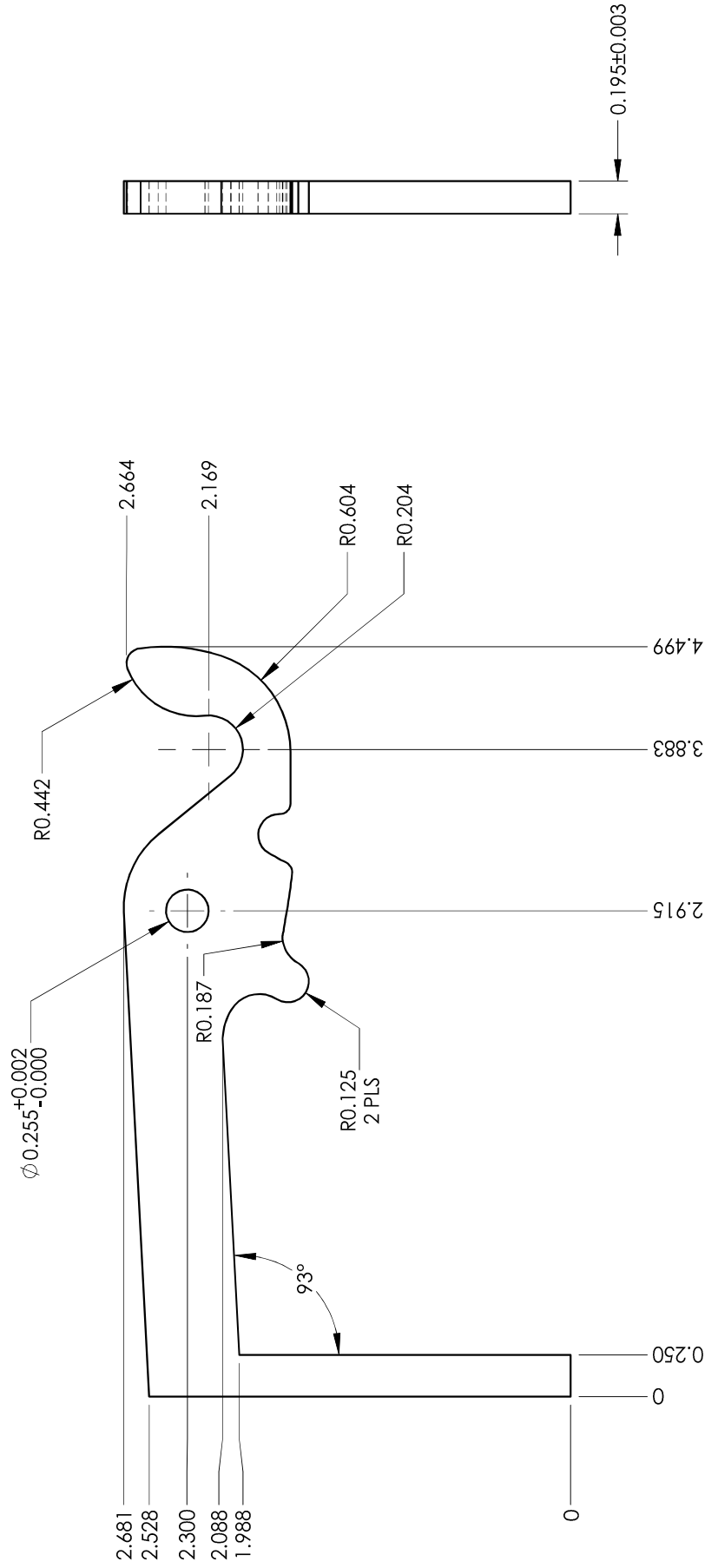

UNLESS OTHERWISE NOTED OR DEPICTED ALL DIMENSIONS ARE OUTSIDE IN INCHES ALL SURFACES ARE CONSIDERED CLASS "B" TOLERANCES: ALL DIMENSIONS ±0.015"	TITLE: <b>HANDLE, EP13 DOOR - SHEET METAL INSERT</b>	MODEL: EP13	DRAWING: <b>W325-0077</b>
	MATERIAL: 0.195" HR P&O	0.210 LBS	DRAWN BY: <b>A.RIGDEN</b>
	FINISH: BLACK OXIDE	SCALE: 1:1	MM/DD/YYYY: <b>6/13/2012</b>
	REVISION: <b>B</b> 12/12/2012 (JMD) REVISED FOR BETTER FIT	SHEET 2 OF 2	CHECKED BY: <b>R.TJART</b>



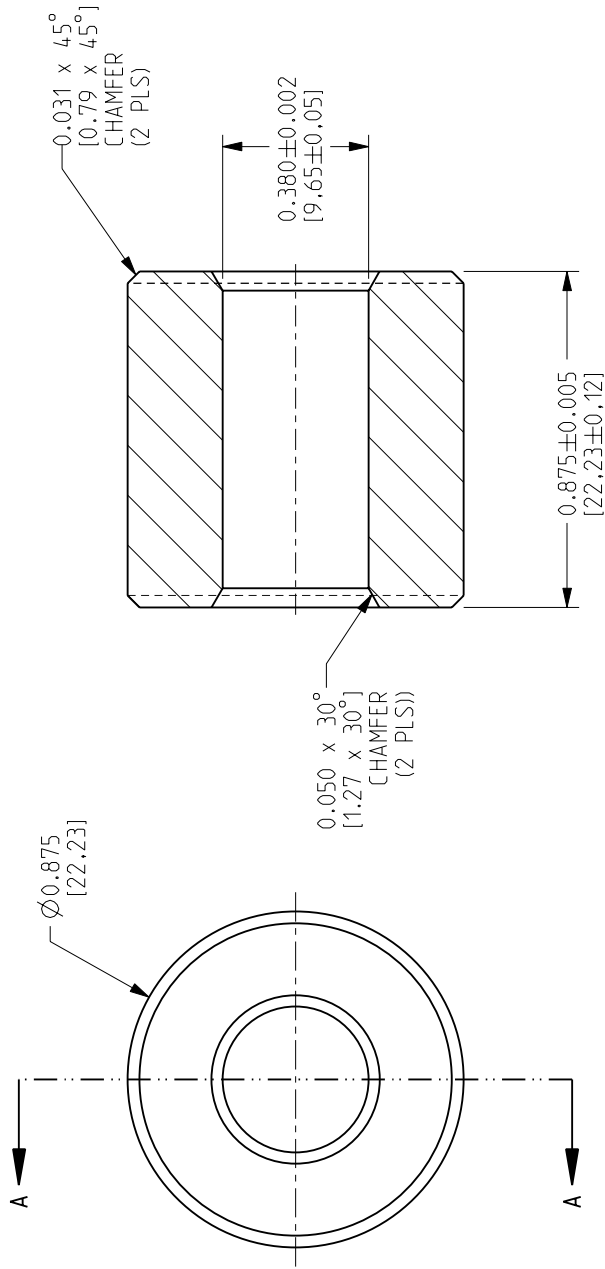

SECTION A-A

NOTE: DIMENSIONS IN BRACKETS ARE IN MM

<b>WOLF STEEL LTD.</b>	<b>TOLERANCES:</b> UNLESS OTHERWISE NOTED WHERE APPLICABLE, FLAT IS SHOWN FORMED PARTS ±0.031 BLANKED PARTS ±0.005 REFERENCE DIMENSION ±0.063 ANGLES ±2°	<b>TITLE:</b> HINGE BUSHING	SCALE 2.000
		<b>MODEL:</b> EPA	<b>DRAWING:</b> W330-0006
		<b>MATERIAL:</b>	<b>DRAWN BY:</b> A. ZHANG
		<b>REVISION:</b> F 030509 (AGR) FIX MODEL & ADD METRIC DIMS	<b>DATE:</b> 03.19.93
			<b>CHECKED BY:</b> JFK

NOTE: BREAK ALL EDGES

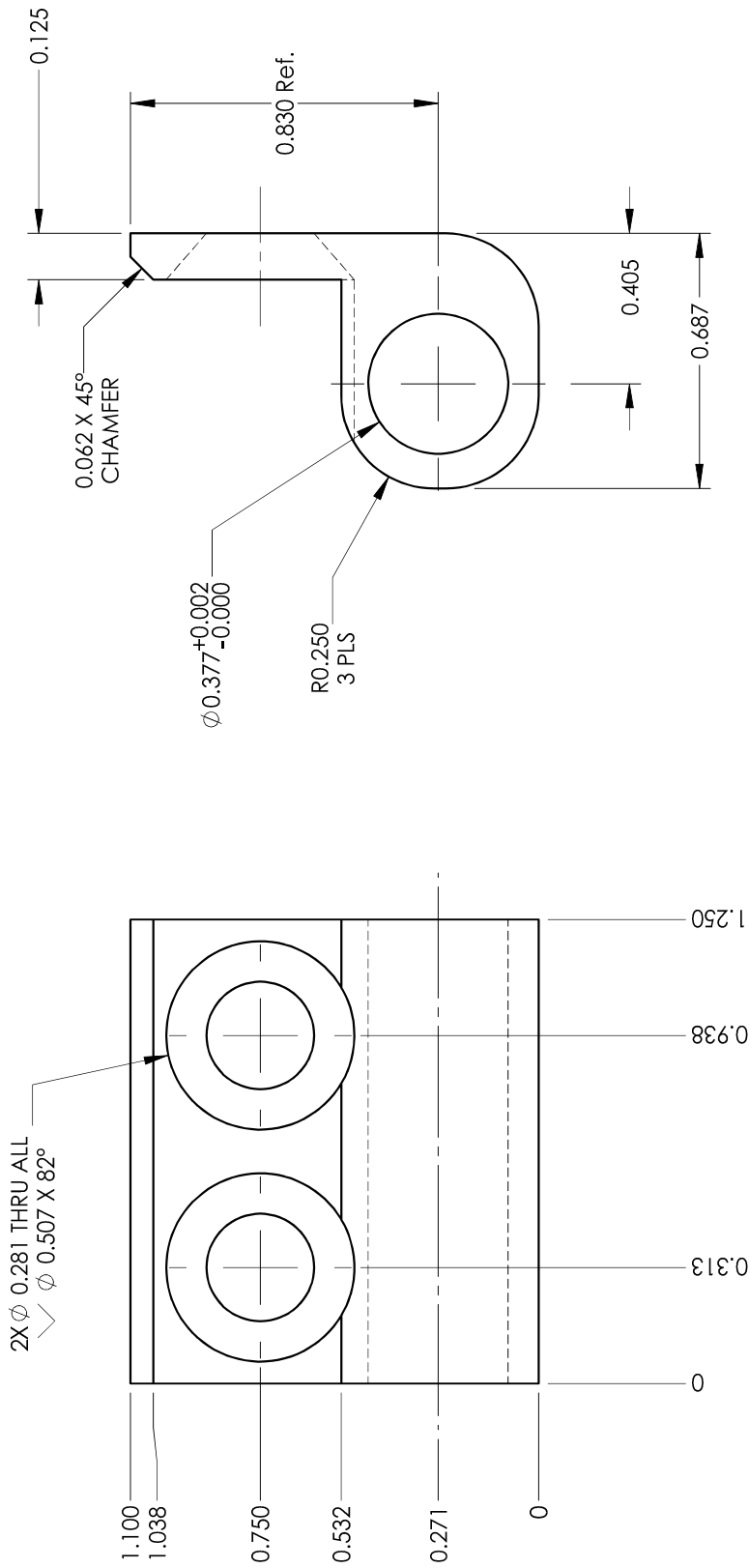

<p>UNLESS OTHERWISE NOTED OR DEPICTED ALL DIMENSIONS ARE OUTSIDE IN INCHES ALL SURFACES ARE CONSIDERED CLASS "B"</p>		<p>TITLE: <b>HINGE, UPPER(EPI3 (C,T) DOOR), REPL W330-0083</b></p>	<p>MODEL: <b>EPI3(C,T)</b></p>	<p>DRAWING: <b>W330-0093</b></p>
<p>TOLERANCES: DIMENSIONS ± 0.005" ANGLES ± 1° REFERENCE DIMENSIONS ± 0.031"</p>		<p>MATERIAL: <b>CRS</b></p>	<p>0.089 LBS</p>	<p>DRAWN BY: <b>R.BARARI</b></p>
<p>REVISION: <b>~</b></p>		<p>FINISH: <b>BLACK OXIDE</b></p>	<p>SCALE: <b>2:1</b></p>	<p>CHECKED BY: <b>CLIFF</b></p>
		<p>SHEET 1 OF 1</p>	<p>MM/DD/YYYY: <b>05/04/2017</b></p>	

The drawing is the property of Wolf Steel Ltd., or NAC. It is to be used only for the project and for the quantity specified. All rights are reserved.

**WOLF STEEL™**  
**NAC**  
 PROJECT: WOLF STEEL  
 ADDRESS: 10000 100th Ave S  
 Calgary, Alberta T2C 1A8

10/09/12 AR



NOTE: BREAK ALL EDGES

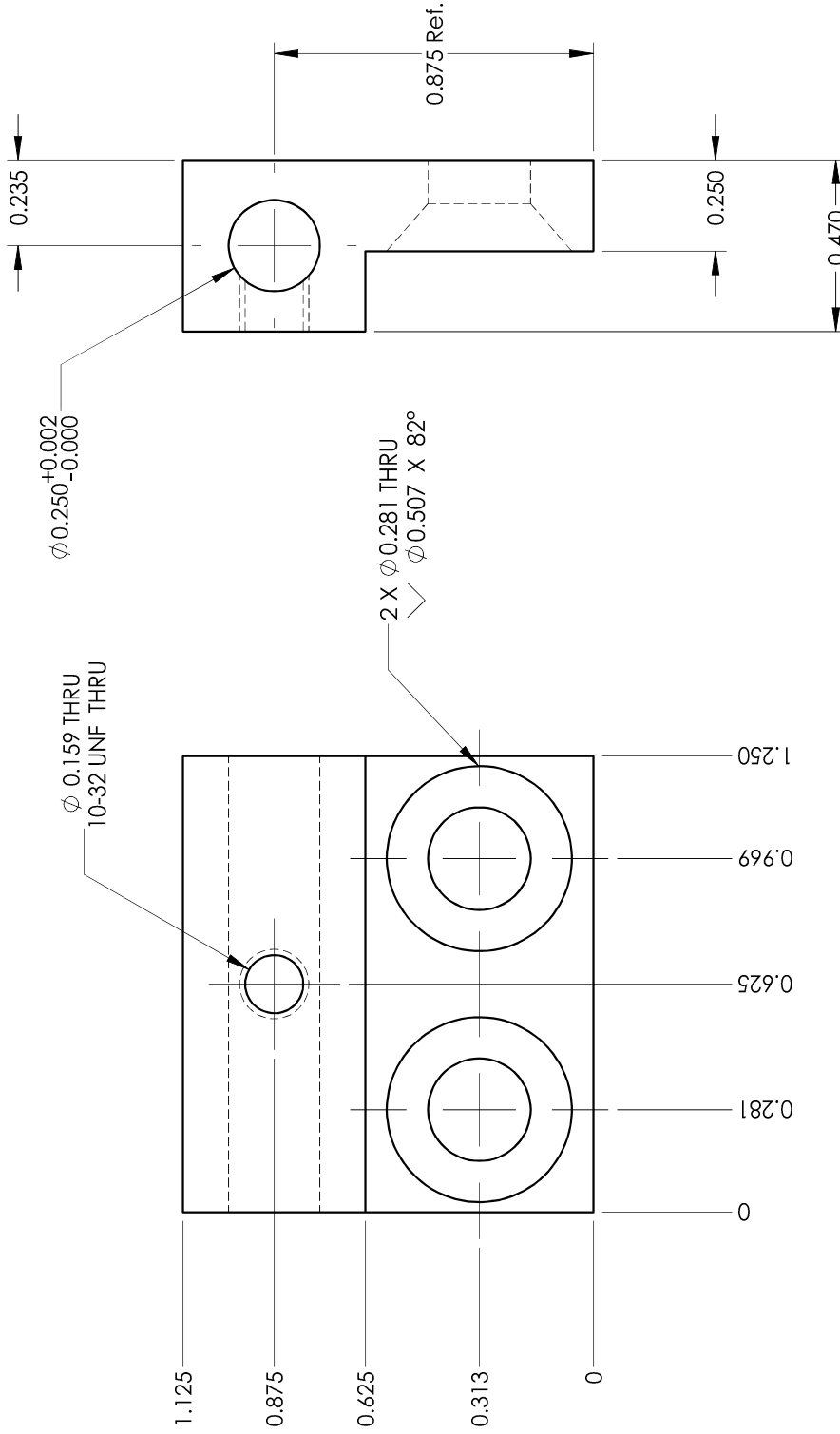

UNLESS OTHERWISE NOTED OR DEPICTED  
ALL DIMENSIONS ARE OUTSIDE IN INCHES  
ALL SURFACES ARE CONSIDERED CLASS "B"

**TOLERANCES:**  
DIMENSIONS ±0.005"  
ANGLES ±1°  
REFERENCE DIMENSIONS ±0.031"

TITLE: HINGE, FRONT CASTING LOWER (REPL W330-0085)  
MODEL: EPI3C  
MATERIAL: CRS  
FINISH: BLACK OXIDE  
REVISION: ~

DRAWING: W330-0096  
DRAWN BY: R.BARARI  
MM/DD/YYYY: 05/08/2017  
SHEET 1 OF 1  
SCALE: 2:1  
CHECKED BY: CLIFF  
0.106 LBS

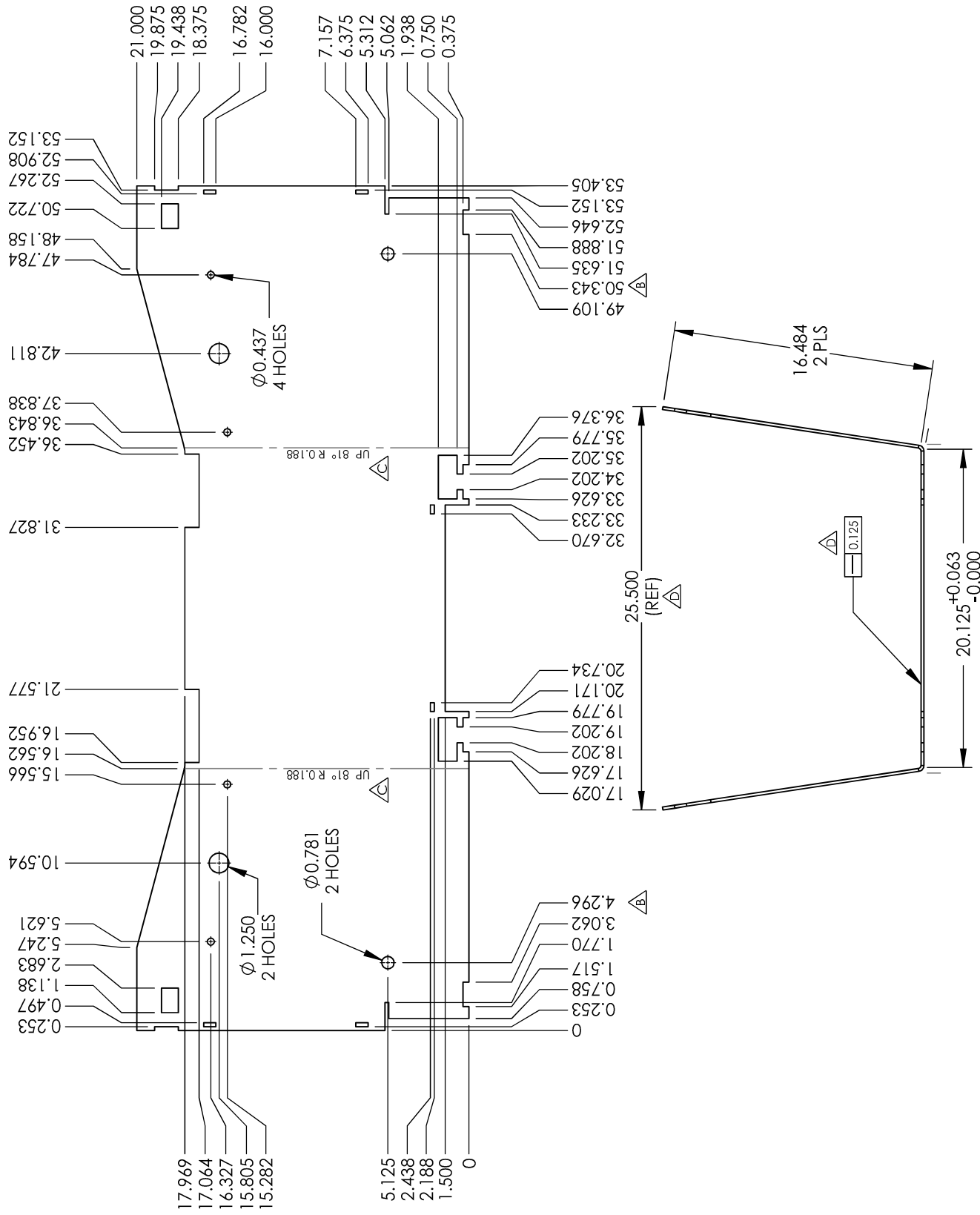

<p>UNLESS OTHERWISE NOTED OR DEPICTED ALL DIMENSIONS ARE OUTSIDE IN INCHES. ALL SURFACES ARE CONSIDERED CLASS "D" REFER TO ENG-009 AND ENG-010 FOR SURFACE FINISH CRITERIA</p> <p>TOLERANCES: FORMED PARTS ±0.031 REFERENCE DIMENSIONS ±0.063 BLANKED PARTS ±0.010 ANGLES ±2°</p>	<p>TITLE: <b>HOUSING, FIREBOX</b></p>	<p>MODEL: <b>W350-0603</b></p>	<p>EPI3 DRAWING: <b>W350-0603</b></p>
	<p>MATERIAL: 3/16 HR P&amp;O</p>	<p>THICKNESS: 0.188</p>	<p>DRAWN BY: <b>A.RIGDEN</b></p>
<p>FINISH:</p>	<p>REVISION: <b>D</b> MM/DD/YY: <b>7/8/2016</b> (AGR) ADD DIMS</p>	<p>SCALE: 1:9</p>	<p>SHEET 1 OF 1</p>
<p>FORMED PARTS ±0.031 REFERENCE DIMENSIONS ±0.063 BLANKED PARTS ±0.010 ANGLES ±2°</p>	<p>51.410 LBS</p>	<p>51.410 LBS</p>	<p>MM/DD/YY: <b>6/13/2012</b></p>
<p>08/27/15 AGR</p>	<p><b>WOLF STEEL</b> NAC NAC STEEL LTD. AUSTIN, TEXAS</p>	<p>CHECKED BY: <b>R.TJART</b></p>	<p>CHECKED BY: <b>R.TJART</b></p>

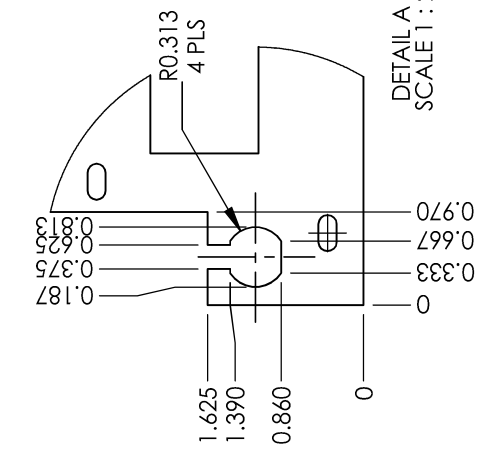
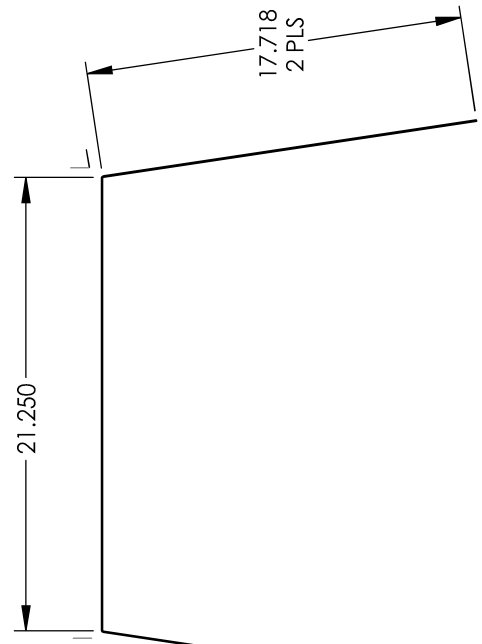
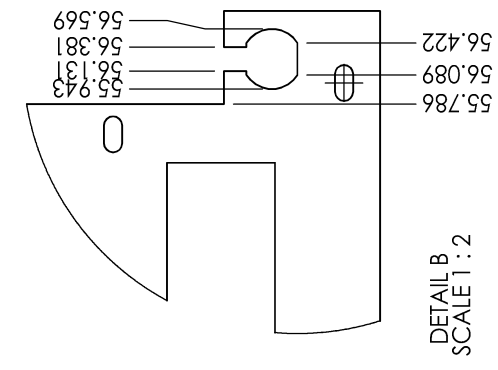
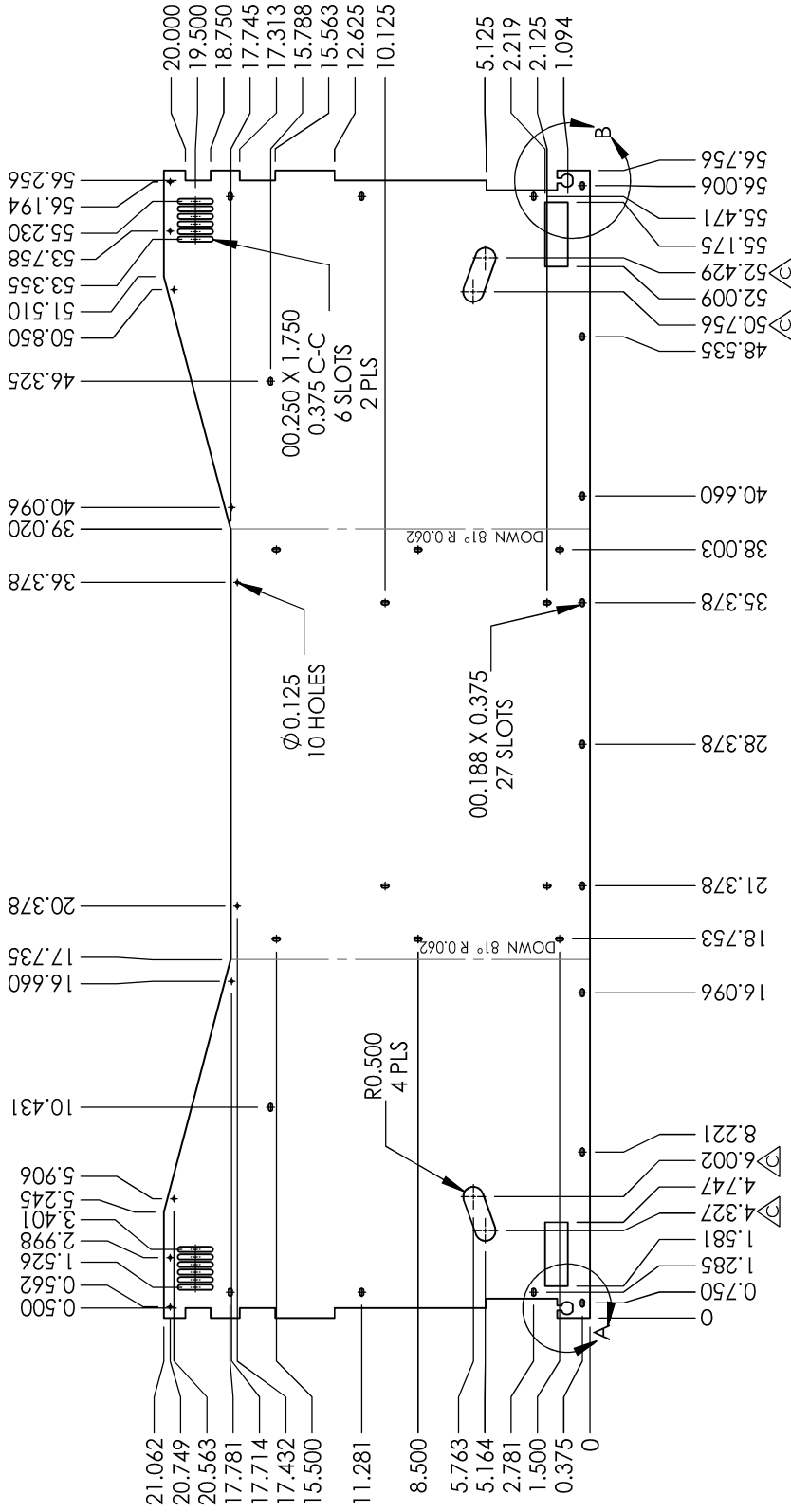

UNLESS OTHERWISE NOTED OR DEPICTED, ALL DIMENSIONS ARE REFERENCED TO CLASS 'D' ALL SURFACES ARE CONSIDERED CLASS 'D' REFER TO ENG-009 AND ENG-010 FOR SURFACE FINISH CRITERIA TOLERANCES: FORMED PARTS: ±0.031 REFERENCE DIMENSIONS ±0.063 BLANKED PARTS: ±0.010 ANGLES ±2	TITLE:	<b>HOUSING, OUTER SHELL</b>		MODEL:	EPI3	DRAWING:	<b>W350-0604</b>
	MATERIAL:	20 GA ALUMINIZED		THICKNESS:	0.039	DRAWN BY:	<b>A.RIGDEN</b>
	FINISH:			SCALE:	1:9	SHEET 1 OF 1	<b>6/13/2012</b>
	REVISION:	<b>C</b>	<b>5/24/2013</b>	(AGR) MODIFY DIMS		CHECKED BY:	<b>R.TJART</b>
	WEIGHT:	11.548 LBS					



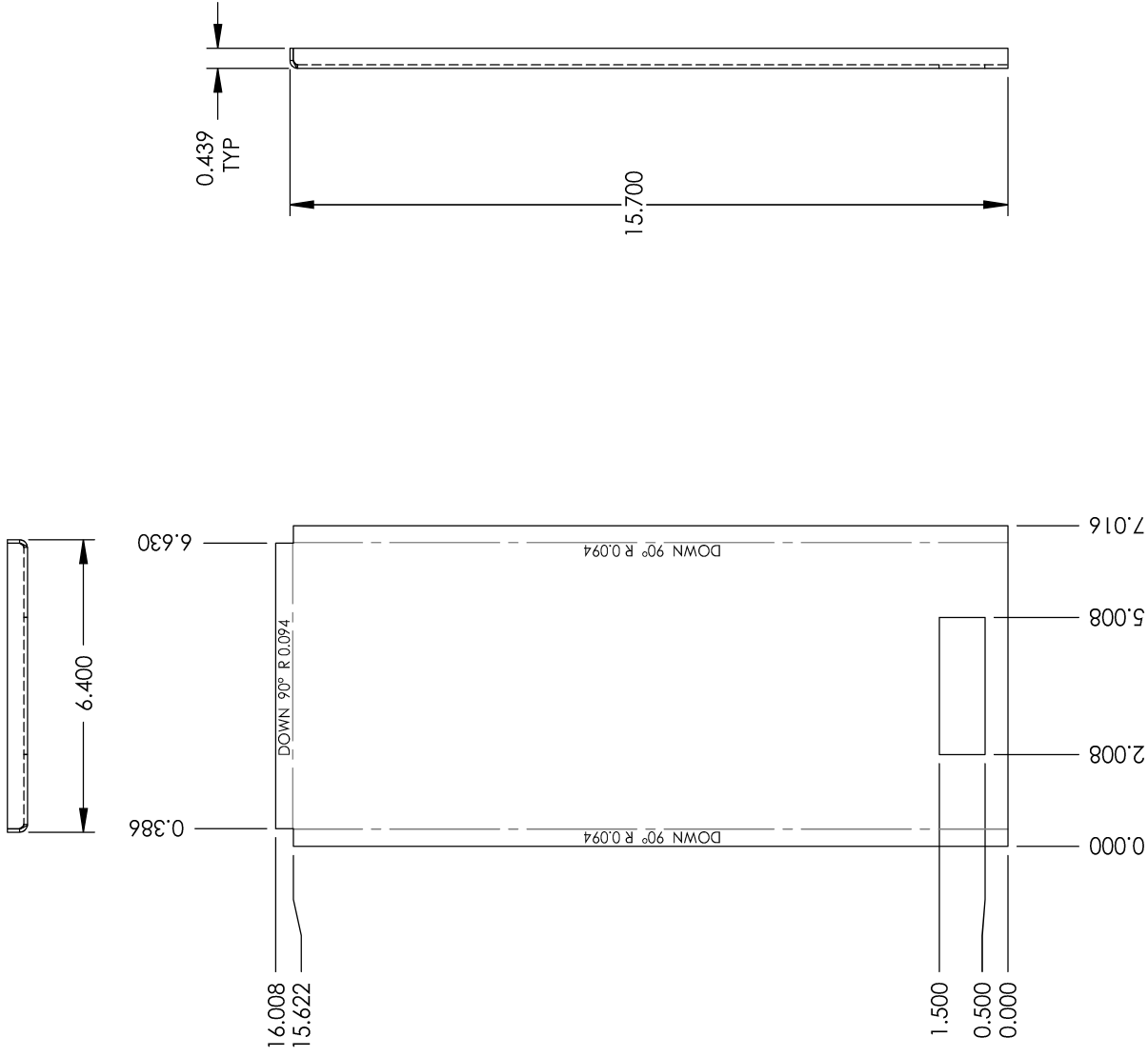

UNLESS OTHERWISE NOTED OR DEPICTED ALL DIMENSIONS ARE OUTSIDE IN INCHES ALL SURFACES ARE CONSIDERED CLASS "D" REFER TO ENG-009 FOR SURFACE FINISH CRITERIA TOLERANCES: FORMED PARTS ±0.031 REFERENCE DIMENSIONS ±0.063 BLANKED PARTS ±0.010 ANGLES ±2°	TITLE: HOUSING, S/A VERTICAL	MODEL: EPI3-1	DRAWING: W350-0930
	MATERIAL: 14 GA HR P&O	THICKNESS: 2.303 LBS	ISSUE DATE: 0.075
FINISH:	PROJECT LEAD: P HODGES	SCALE: 1:4	DRAWN BY: MS
REVISION: P02	REV DATE: 03/22/19	SHEET 1 OF 1	CHECKED BY: UNRELEASED



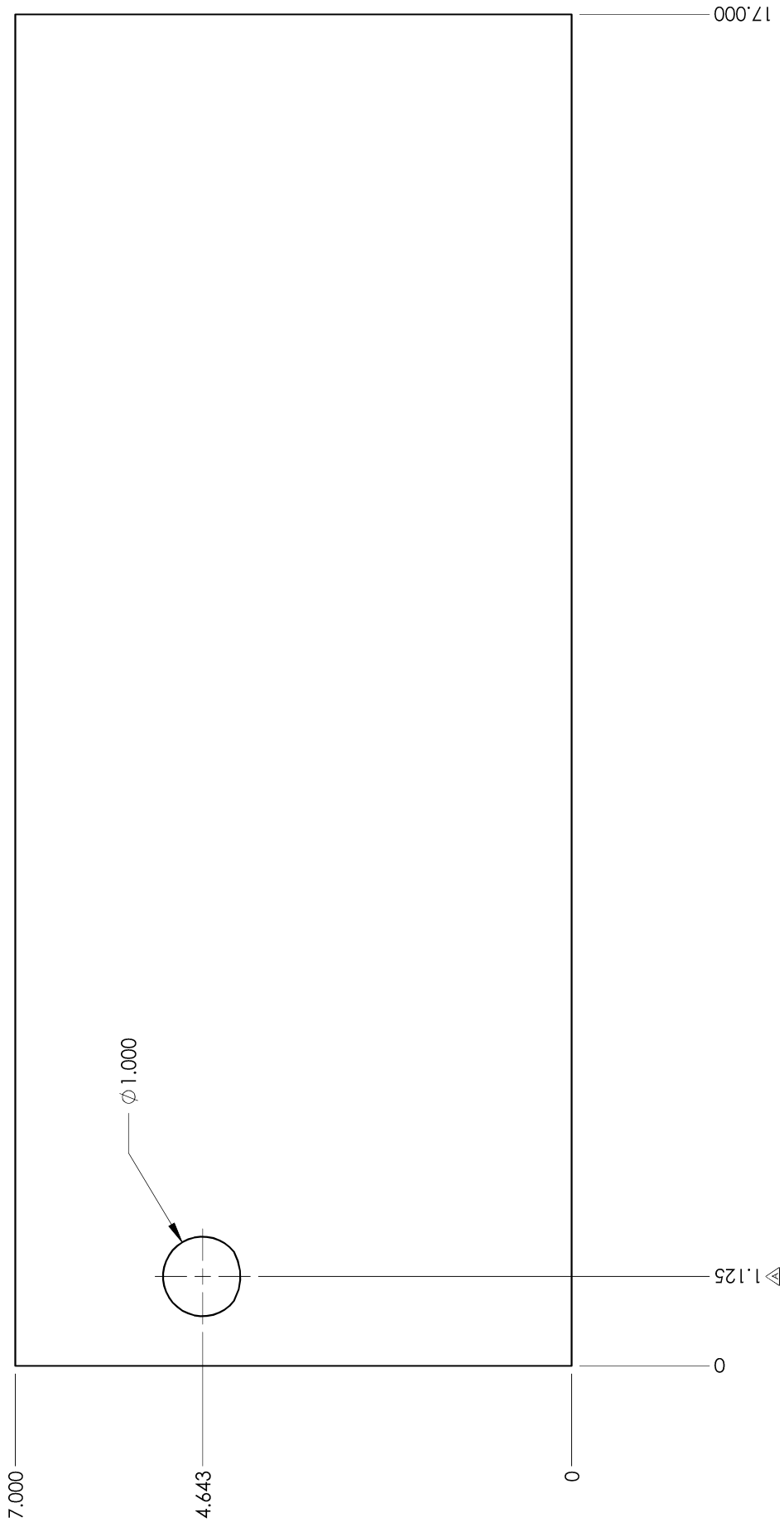

01.09.12 AR

**WOLF STEEL**<sup>TM</sup>  
**NAC**  
 Precision in  
 Architecture  
 Construction

UNLESS OTHERWISE NOTED OR DEPICTED  
 ALL DIMENSIONS ARE OUTSIDE IN INCHES  
 ALL SURFACES ARE CONSIDERED CLASS 10

**TOLERANCES:**  
 DIMENSIONS ±0.003"  
 REFERENCE DIMENSIONS ±0.125"  
 ANGLES ±2°

**TITLE:** INSULATION, BLOWER HOUSING  
**MATERIAL:** 1/2" CERAMIC FIBRE BLANKET  
**FINISH:**  
**REVISION:** A 7/24/2012 (AGR) ADD DIM

**MODEL:** EP13  
**DRAWING:** W361-0182  
**DRAWN BY:** A.RIGDEN  
**SCALE:** 1:2 SHEET 1 OF 1  
**MM/DD/YYYY:** 7/4/2012  
**CHECKED BY:** R.TJART

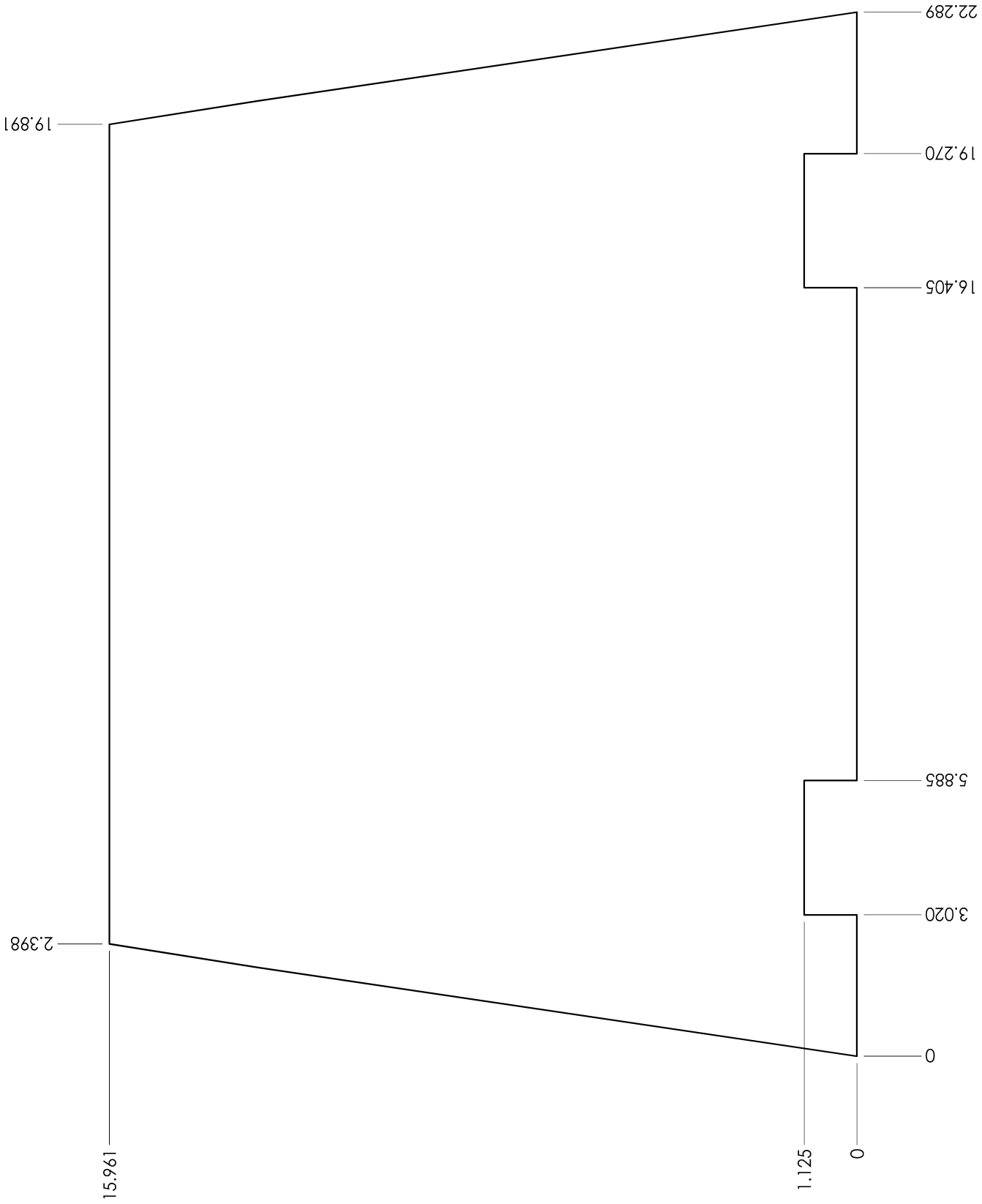

<p><b>UNLESS OTHERWISE NOTED OR DEPICTED</b>          ALL DIMENSIONS ARE OUTSIDE IN INCHES          ALL SURFACES ARE CONSIDERED CLASS 10<sup>1</sup></p> <p><b>TOLERANCES:</b>          DIMENSIONS ±0.003"          REFERENCE DIMENSIONS ±0.125"          ANGLES ±2°</p>		<p><b>TITLE:</b> INSULATION, FIREBOX BASE</p> <p><b>MATERIAL:</b> 1/8" CERAMIC FIBRE PAPER (2150°F)</p> <p><b>FINISH:</b></p> <p><b>REVISION:</b> 2</p>	<p><b>MODEL:</b> EP13</p> <p><b>SCALE:</b> 1:3</p> <p><b>SHEET 1 OF 1</b></p>	<p><b>DRAWING:</b> W361-0189</p> <p><b>DRAWN BY:</b> A.RIGDEN</p> <p><b>MM/DD/YYYY:</b> 2/8/2013</p> <p><b>CHECKED BY:</b> R.TJART</p>
--	--	---	---	--

This drawing is the property of Wolf Steel Ltd. or NAC. It is not to be used, copied, or reproduced without our consent. All rights are reserved.

**WOLF STEEL**<sup>TM</sup>  
**NAC**  
 Energy Efficient  
 Steel Structures  
 Corporation

02.20.13 AR

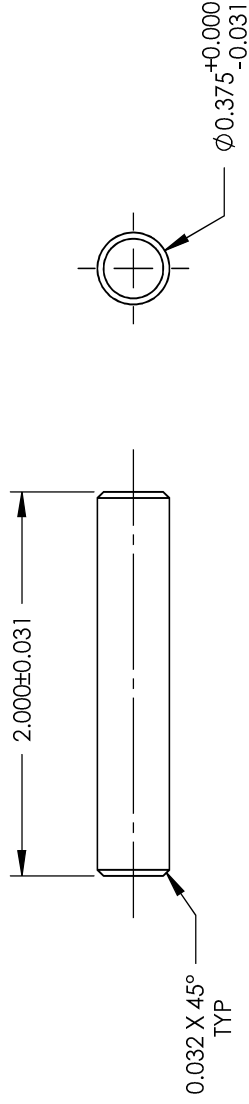

This drawing is the property of Wolf Steel Ltd. or NAC. It is to be used for the specific project and is not to be used for any other project without our consent. All rights are reserved.



**WOLF STEEL**<sup>TM</sup>  
**NAC**  
NAC is a brand name for  
NAC Ltd. or NAC  
Company Ltd.

UNLESS OTHERWISE NOTED OR DEPICTED  
ALL DIMENSIONS ARE OUTSIDE IN INCHES

TOLERANCES:  
DIMENSIONS ±0.062"  
REFERENCE DIMENSIONS ±0.125"  
ANGLES ±2°

TITLE: **PIN, HINGE**

MATERIAL: 0.375Ø DRWN CRS WIRE

FINISH:

REVISION: **D** 9/20/2010 (M.A.) MODELLED IN SW

MODEL: GDS50

0.062 LBS

SCALE: 1:1 SHEET 1 OF 1

DRAWING: **W485-0010**

DRAWN BY: **RICH**

MM/DD/YYYY: **7/10/1996**

CHECKED BY: **JFK**

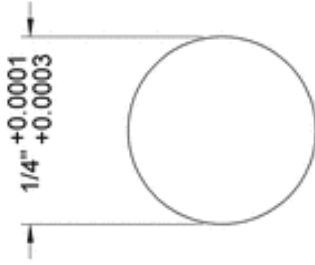

NOTE: Alloy Steel

**Reference Only**

WOLF STEEL

TITLE: PIN, DOWEL 1/4" x 3/4"

DWG #: W485-0052

REV:

DATE: 12.06.12\_RT



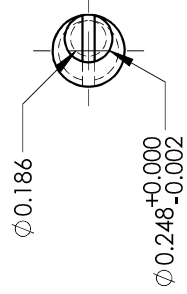
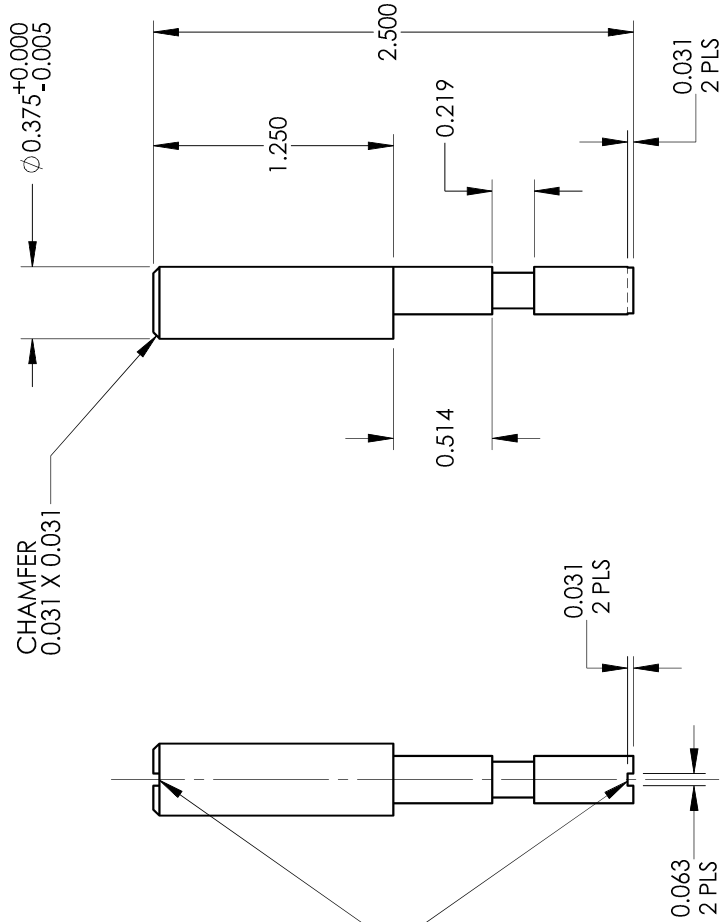
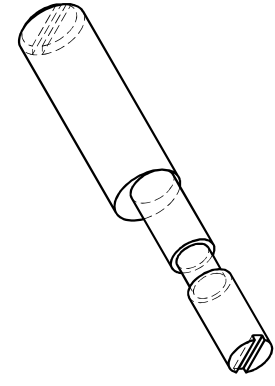

NOTE: BOTH ENDS  
MUST HAVE SLOT

The drawing is the property of Wolf Steel Ltd. or NAC. It is to be used only for the specific order and without our consent. All rights are reserved.

**WOLF STEEL™**  
**NAC** Precision in Any Language

UNLESS OTHERWISE NOTED OR DEPICTED  
ALL DIMENSIONS ARE OUTSIDE IN INCHES  
ALL SURFACES ARE CONSIDERED CLASS "B"

TOLERANCES:  
DIMENSIONS ±0.005"  
ANGLES ±1°

TITLE:	PIN, ADJUSTABLE CAM HINGE	MODEL:	EPT3	DRAWING:	W485-0053
MATERIAL:	CRS		0.054 LBS	DRAWN BY:	A.RIGDEN
FINISH:	BLACK OXIDE		SHEET 1 OF 1	MM/DD/YYYY:	6/18/2013
REVISION:	~			CHECKED BY:	R.TJART

LASER CHECKED

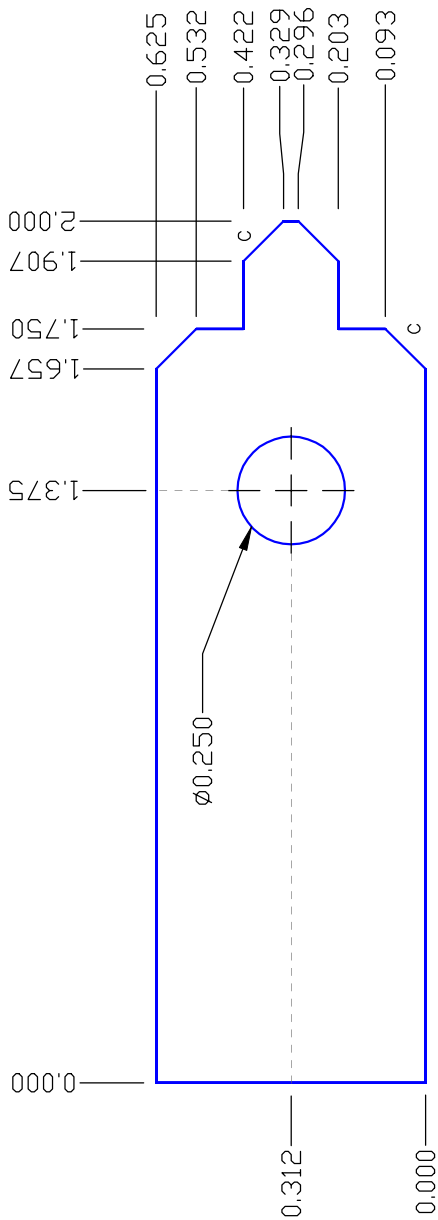

WOLF STEEL LTD.

TITLE: AIR TUBE RETAINER

MATERIAL: 14 GA ST. ST. P 0.074x0.625x2.000

REVISION: C:01.10.05||CHAMFER & UPDATE DWG# D:01.11.05||EDIT MAT'L DESCRIPTION

NZ26

DRAWING #: W500-0141 c

DATE: 08.25.99

CHECKED BY: JFK

TOLERANCES: UNLESS OTHERWISE NOTED,  
FORMED PARTS  $\pm 0.031$   
BLANKED PARTS  $\pm 0.005$   
REFERENCE DIMENSIONS  $\pm 0.063$   
ANGLES  $\pm 2^\circ$

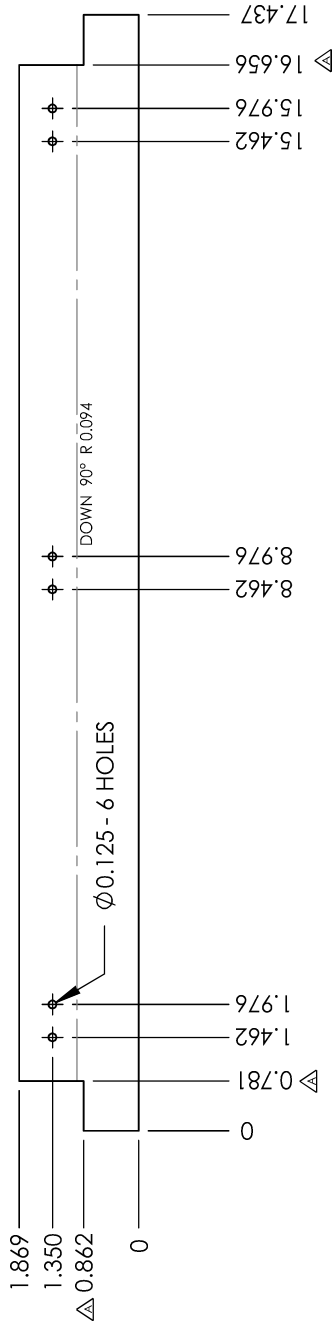
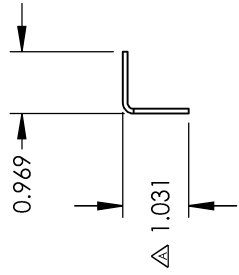

<p>UNLESS OTHERWISE NOTED OR DEPICTED ALL DIMENSIONS ARE OUTSIDE IN INCHES</p> <p>TOLERANCES: WHERE APPLICABLE, FLAT IS SHOWN FINISHED SIDE UP</p> <p>FORMED PARTS ±0.031" BLANKED PARTS ±0.010" REFERENCE DIMENSIONS ±0.063" ANGLES ±2°</p>	<p>TITLE: <b>RETAINER, OUTER SHELL (REAR)</b></p>	<p>MODEL: EP13</p>	<p>DRAWING: <b>W500-0575</b></p>
	<p>MATERIAL: 14 GA HR P&amp;O</p>	<p>THICKNESS: 0.075</p>	<p>DRAWN BY: <b>A.RIGDEN</b></p>
	<p>FINISH:</p>	<p>SCALE: 1:3</p>	<p>SHEET 1 OF 1</p>
	<p>REVISION: <b>A</b> 1/28/2013 (AGR) ADD MTL/ADD NOTCHES</p>	<p>0.654 LBS</p>	<p>CHECKED BY: R.TJART</p>





NOTES:  
NOTE 1 MUST BE BURR FREE

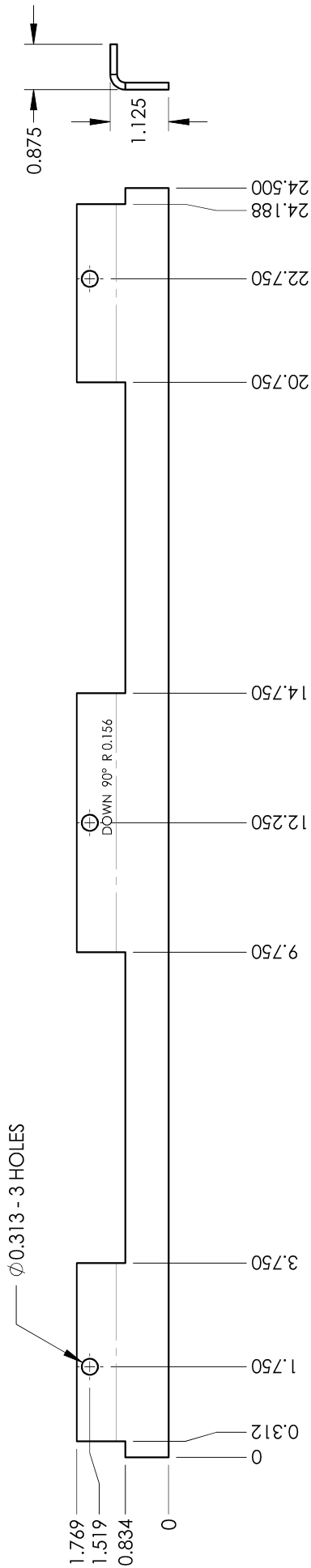
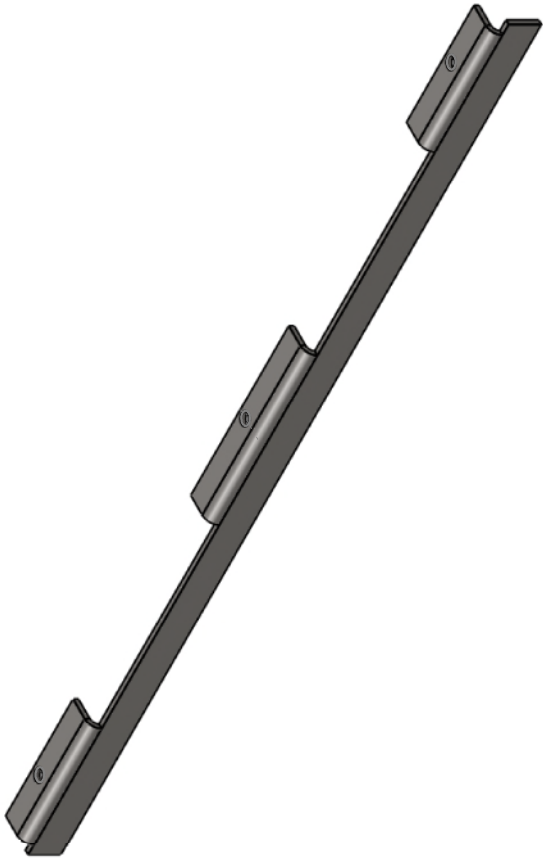

This drawing is the property of Wolf Steel Ltd. or NCC. It is not to be used in any manner without our consent. All rights are reserved.		UNLESS OTHERWISE NOTED OR DEPICTED ALL DIMENSIONS ARE OUTSIDE IN INCHES ALL SURFACES ARE CONSIDERED CLASS "D"		TITLE: <b>PLATE, SMOKE SHELF</b>		MODEL: <b>EPI3-1</b>		DRAWING: <b>W500-0647</b>	
		REFER TO ENG-009 FOR SURFACE FINISH CRITERIA		MATERIAL: <b>10 GA HR P&amp;O</b>		THICKNESS: <b>0.135</b>		ISSUE DATE: <b>6/13/2012</b>	
TOLERANCES: FORMED PARTS $\pm 0.031$ REFERENCE DIMENSIONS $\pm 0.063$ BLANKED PARTS $\pm 0.010$ ANGLES $\pm 2$		FINISH:		PROJECT LEAD: <b>P HODGES</b>		SCALE: <b>1:3</b>		SHEET <b>1 OF 1</b>	
DATE FOR WAT MM/DD/YY		REVISION: <b>P00</b>		REV DATE: <b>6/19/2018</b>		REV NOTE:		CHECKED BY: <b>UNRELEASED</b>	

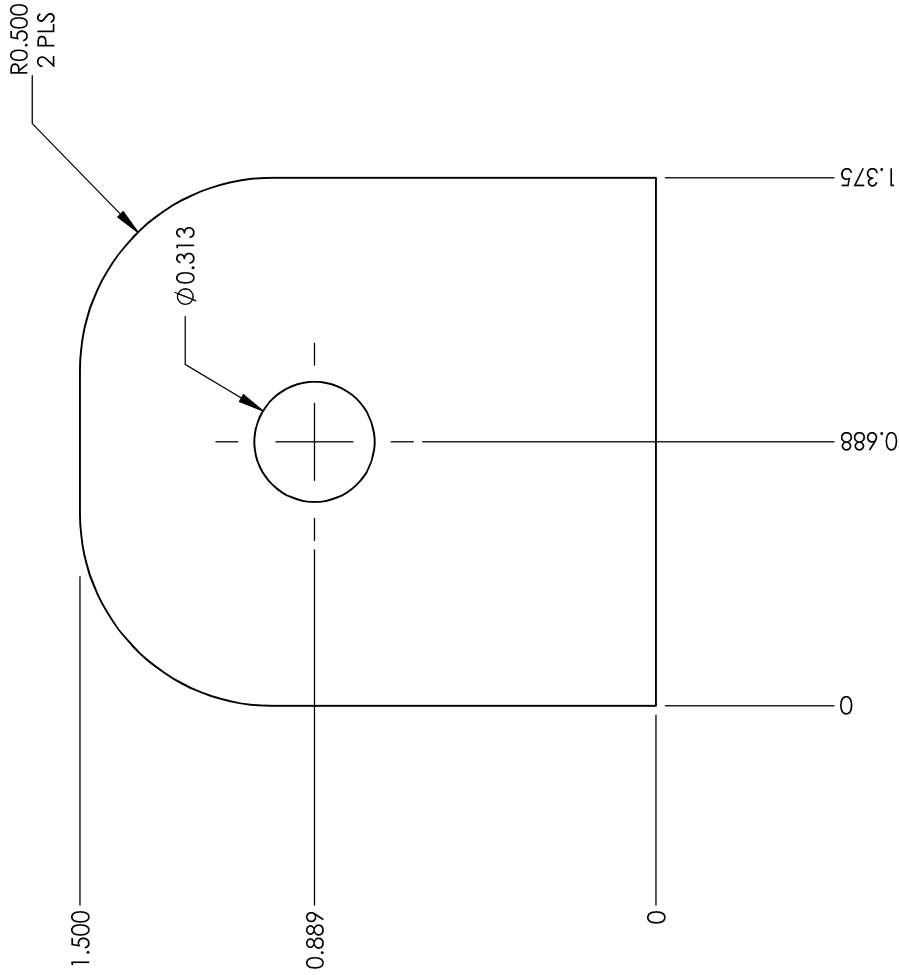

UNLESS OTHERWISE NOTED OR DEPICTED  
 ALL DIMENSIONS ARE OUTSIDE IN INCHES  
 UNLESS OTHERWISE SPECIFIED  
 WHERE APPLICABLE FLAT IS SHOWN FINISHED SIDE UP

**TOLERANCES:**  
 FORMED PARTS ±0.031"  
 BEVEL PARTS ±0.003"  
 SURFACE DIMENSIONS ±0.003"  
 ANGLES ±2°



This drawing is the property of Wolf Steel LTD., or NAC. It is to be used only for the project and location specified hereon. All rights are reserved.



TITLE:	RETAINER, FLUE COLLAR	MODEL:	EP13	DRAWING:	W500-0691
MATERIAL:	3/16 HR P&O	THICKNESS:	0.188	DRAWN BY:	A.RIGDEN
FINISH:		SCALE:	2:1	MM/DD/YYYY:	6/13/2012
REVISION:	-			CHECKED BY:	R.TJART

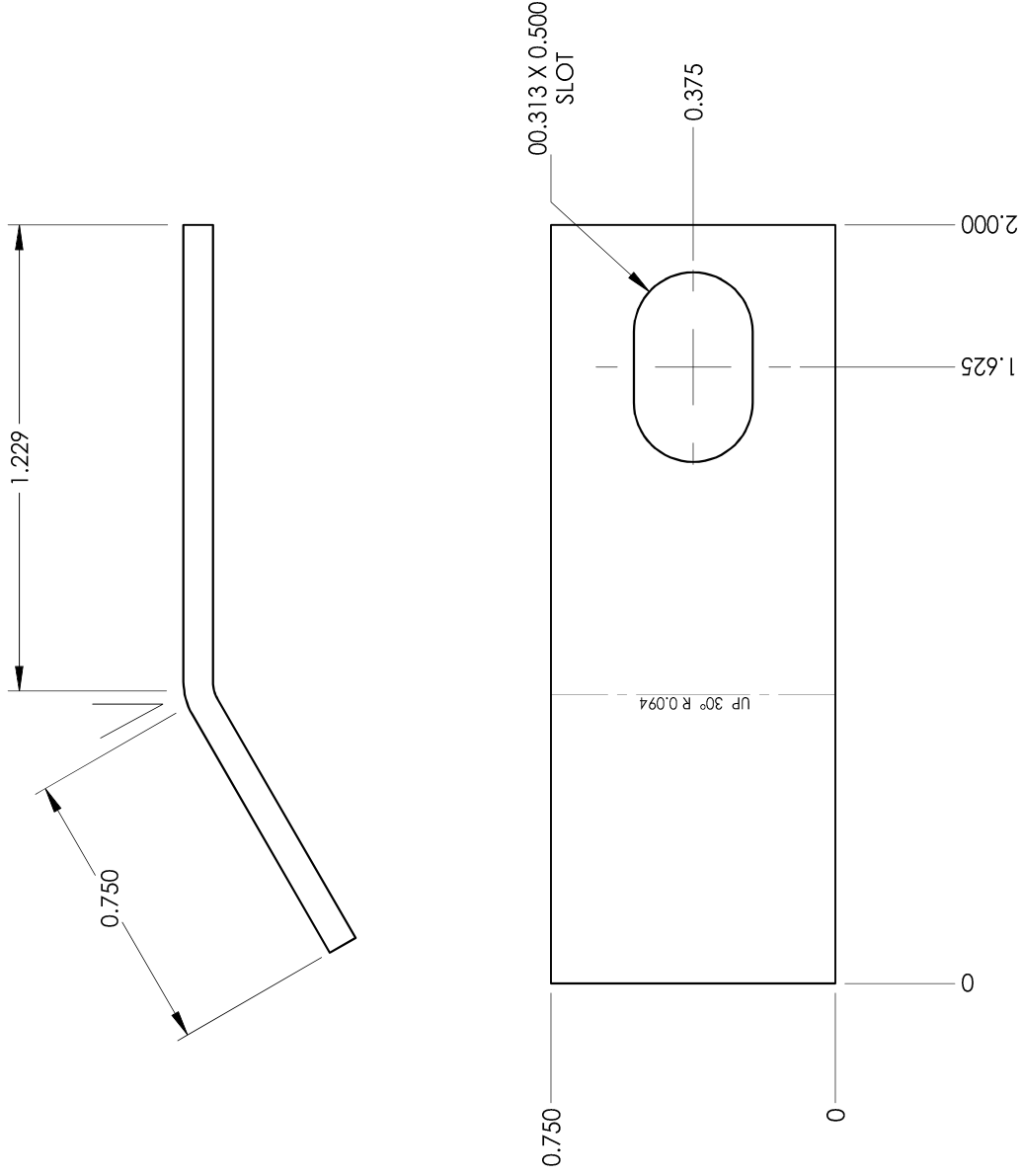

UNLESS OTHERWISE NOTED OR DEPICTED  
 ALL DIMENSIONS ARE OUTSIDE IN INCHES  
 UNLESS OTHERWISE SPECIFIED  
 WHERE APPLICABLE FLAT IS SHOWN FINISHED SIDE UP

**TOLERANCES:**  
 FORMED PARTS ±0.031"  
 BEADED PARTS ±0.031"  
 SURFACE DIMENSIONS ±.005"  
 ANGLES ±2°

The drawing is the property of Wolf Steel LTD., or NAC. It is to be used only for the project and order number shown hereon and may not be reproduced or used in any manner without our consent. All rights are reserved.

**WOLF STEEL<sup>TM</sup>**  
**NAC** Manufactured in America  
 10109.12 AR

<b>TITLE:</b> RETAINER, BRICK (FRONT)	<b>MODEL:</b> EP13	<b>DRAWING:</b> W500-0693
<b>MATERIAL:</b> 14 GA SS 430-2B	<b>THICKNESS:</b> 0.031 LBS	<b>DRAWN BY:</b> A.RIGDEN
<b>FINISH:</b>	<b>SCALE:</b> 2:1	<b>MM/DD/YYYY:</b> 7/6/2012
<b>REVISION:</b> -	<b>SHEET 1 OF 1</b>	<b>CHECKED BY:</b> R.TJART

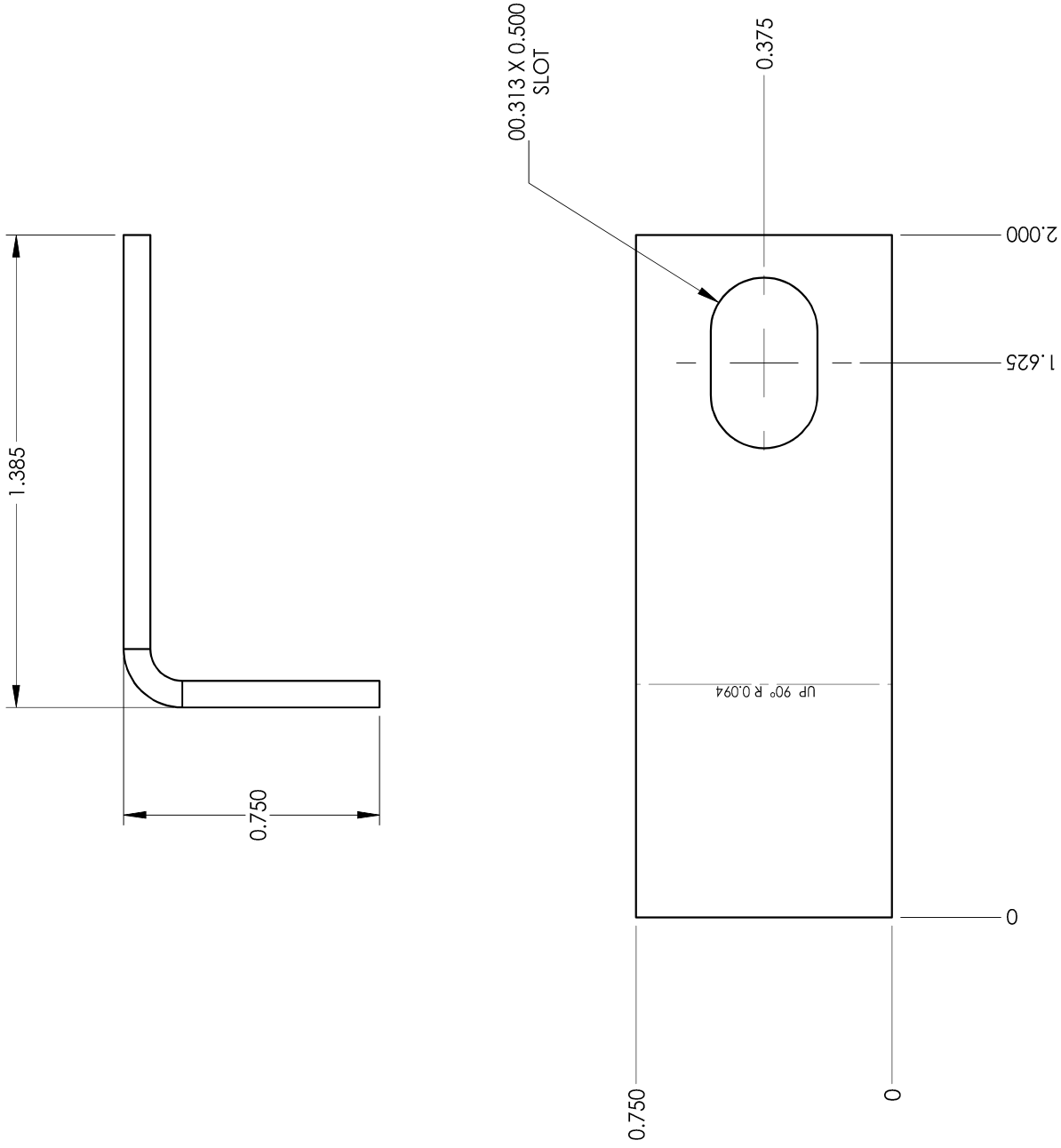

<p>UNLESS OTHERWISE NOTED OR DEPICTED ALL DIMENSIONS ARE OUTSIDE IN INCHES WHERE APPLICABLE. FLAT IS SHOWN FINISHED SIDE UP</p>		<p>TITLE: <b>RETAINER, BRICK (REAR)</b></p>		<p>MODEL: EP13</p>		<p>DRAWING: <b>W500-0694</b></p>	
<p>FORMED PARTS ±0.031" BLANKED PARTS ±0.003" SURFACE DIMENSIONS ±2° ANGLES</p>		<p>MATERIAL: 14 GA SS 430-2B</p>		<p>THICKNESS: 0.078</p>		<p>DRAWN BY: <b>A.RIGDEN</b></p>	
<p>TOLERANCES:</p>		<p>FINISH:</p>		<p>SCALE: 2:1</p>		<p>SHEET 1 OF 1</p>	
<p>0</p>		<p>REVISION: -</p>		<p>CHECKED BY: R.TJART</p>		<p>DATE: 7/6/2012</p>	

This drawing is the property of Wolf Steel LTD., or NAC. It is to be used only for the project and order number shown hereon and is not to be reproduced or used in any manner without our consent. All rights are reserved.

**WOLF STEEL**<sup>TM</sup>  
**NAC**

Manufactured in  
Australia  
CORPORATION

01/09.12 AR



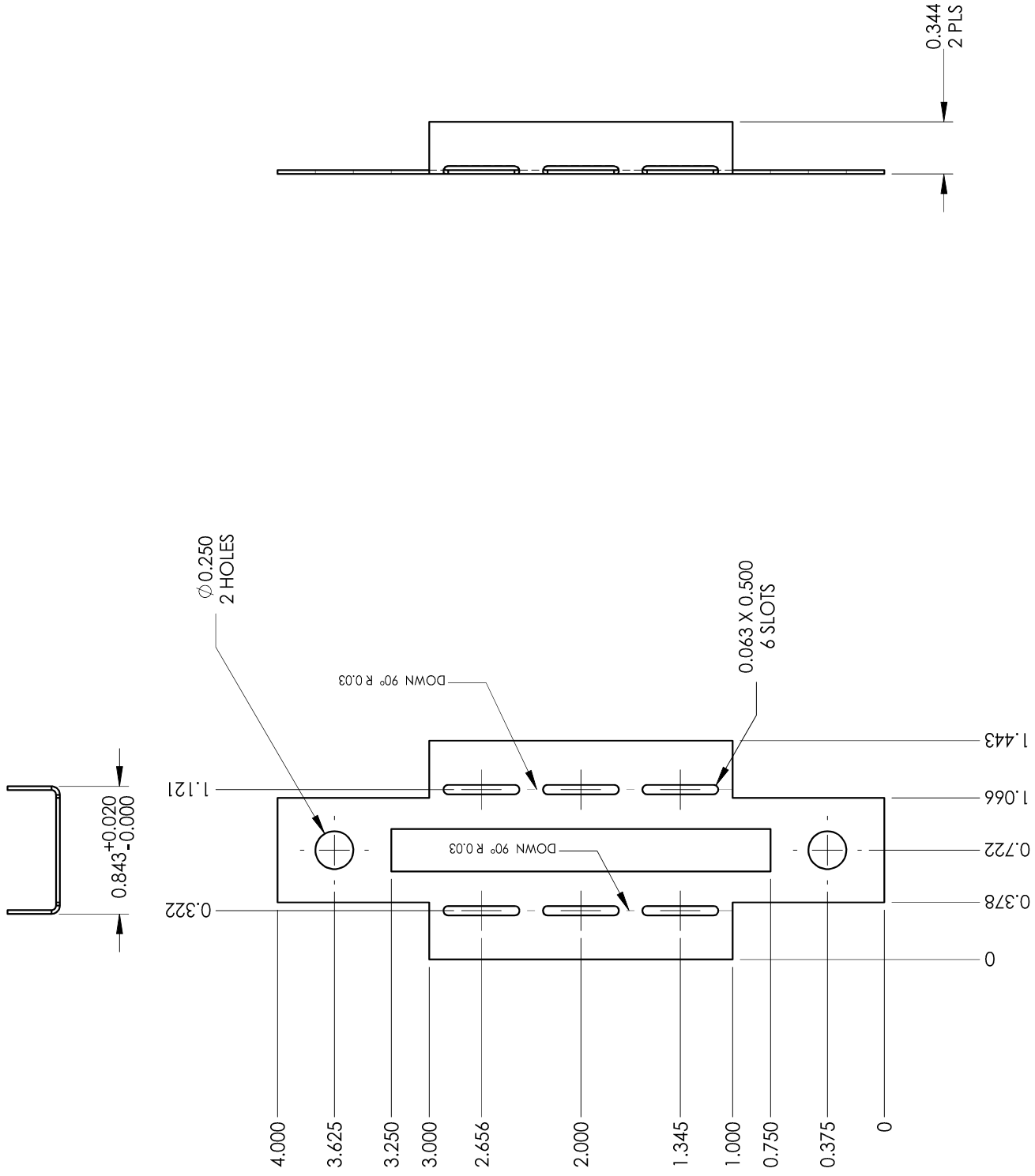

UNLESS OTHERWISE NOTED OR DEPICTED: ALL DIMENSIONS ARE REFERENCED TO CLASS 'D' ALL SURFACES ARE CONSIDERED CLASS 'D' REFER TO ENG-009 AND ENG-010 FOR SURFACE FINISH CRITERIA	TITLE:	RETAINER, PIN	MODEL:	EPT3	DRAWING:	W500-0700
	MATERIAL:	24 GA SS 430-2B	THICKNESS:	0.025	DRAWN BY:	J.DUCHESNE
FINISH:			SCALE:	1:1	SHEET 1 OF 1	3/18/2013
TOLERANCES: FORMED PARTS: ±0.031 BLANKED PARTS: ±0.010	REVISION:	A	DATE:	6/10/2013	(AGR) MAKE PART SYMMETRICAL/ADD FORM VIEW	CHECKED BY:

This drawing is the property of Wolf Steel LTD. or NAC.  
 It is to be used only for the specific part identified  
 without our consent. All rights are reserved.

**WOLF STEEL™**  
**NAC**  
 Precision in  
 Steel Products

02.20.13 AR

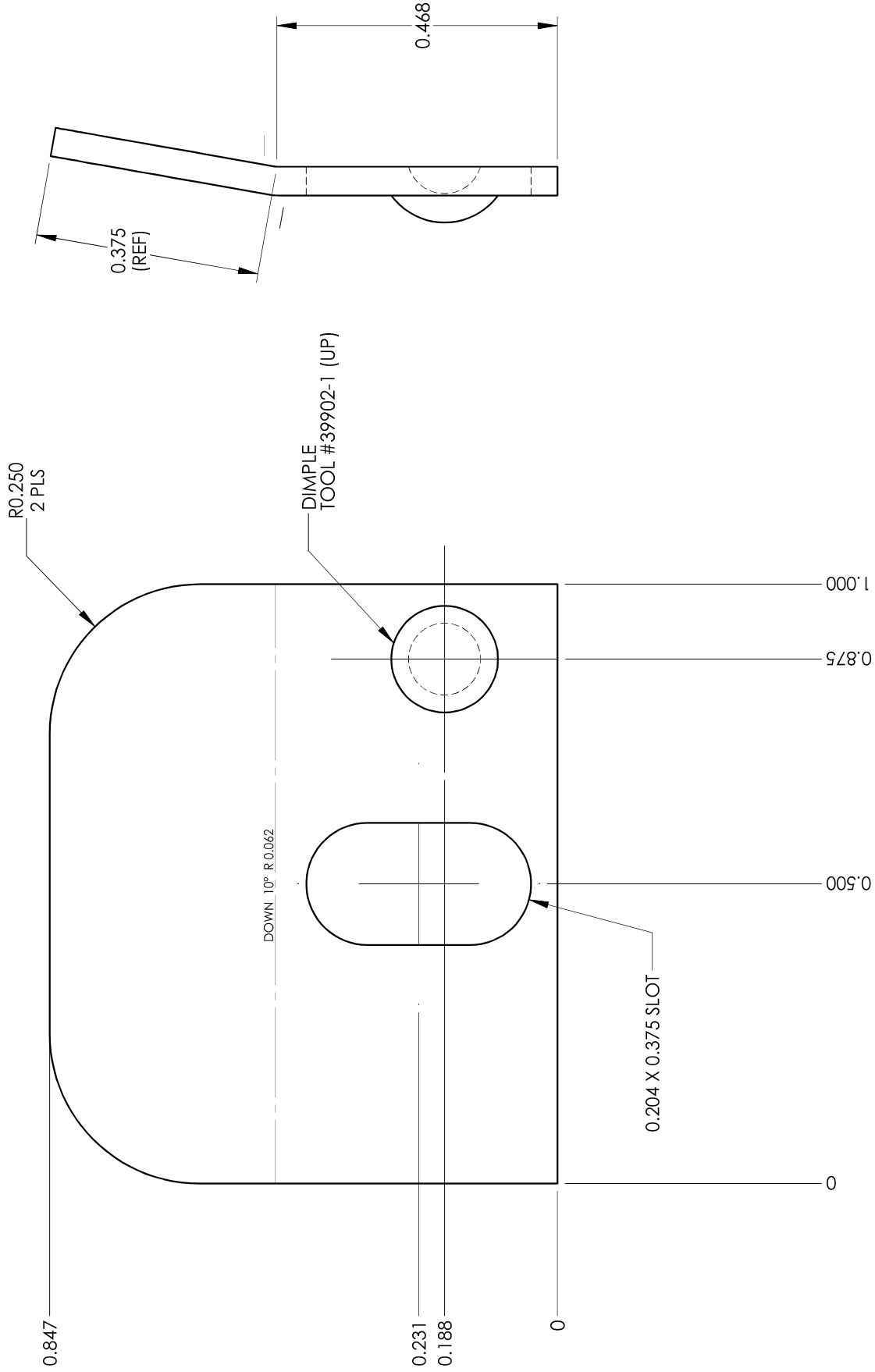

UNLESS OTHERWISE NOTED OR DEPICTED  
ALL DIMENSIONS ARE OUTSIDE IN INCHES  
UNLESS OTHERWISE SPECIFIED  
WHERE APPLICABLE, FINISH IS SHOWN FINISHED SIDE UP

TOLERANCES:  
FORMED PARTS ±0.031"  
MACHINED PARTS ±0.005"  
SURFACE DIMENSIONS ±.2°  
ANGLES

This drawing is the property of Wolf Steel LTD., or NAC. It is to be used only for the project and quantity specified. All rights are reserved.

**WOLF STEEL**<sup>TM</sup>  
**NAC**  
NORTH AMERICAN  
CORPORATION

TITLE:	RETAINER, GLASS	MODEL:	S4	DRAWING:	W500-0709
MATERIAL:	18 GA CRS	THICKNESS:	0.048	DRAWN BY:	J.DUCHESNE
FINISH:		SCALE:	4:1	SHEET 1 OF 1	11/6/2012
REVISION:	A	1/30/2013	(AGR) ADD DIMPLE	CHECKED BY:	R.TJART
		0.010 LBS			

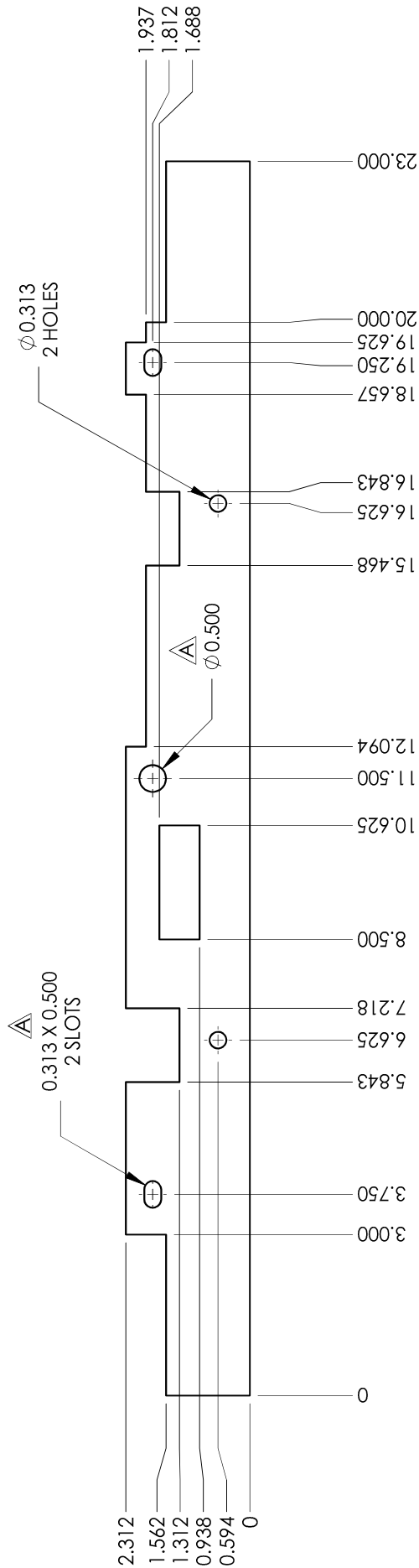

UNLESS OTHERWISE NOTED OR DEPICTED: ALL DIMENSIONS ARE REFERENCED TO CLASS 'D' ALL SURFACES ARE CONSIDERED CLASS 'D' REFER TO ENG-009 AND ENG-010 FOR SURFACE FINISH CRITERIA TOLERANCES: FORMED PARTS: ±0.031 REFERENCE DIMENSIONS ±0.063 BLANKED PARTS: ±0.010 ANGLES ±2	TITLE: <b>RETAINER, CASTING (REPLACES W500-0639)</b>	MODEL: <b>EPI3C</b>	DRAWING: <b>W500-0737</b>
	MATERIAL: <b>14 GA HR P&amp;O</b>	THICKNESS: <b>0.075</b>	DRAWN BY: <b>A.RIGDEN</b>
FINISH:	WEIGHT: <b>0.880 LBS</b>	SCALE: <b>1:3</b>	SHEET <b>1 OF 1</b>
REVISION: <b>A</b>	DATE: <b>6/12/2017</b>	CHECKED BY:	DATE: <b>6/10/2013</b>
(RB) REVISED SLOTS & CREATED A HOLE	CHECKED BY:	DATE:	DATE:

The drawing is the property of Wolf Steel Ltd., or NAC.  
 It is to be used only for the purpose intended.  
 Without our consent, all rights are reserved.

**WOLF STEEL™**  
**NAC**  
 NORTH AMERICAN  
 CASTING COMPANY

02.20.13 AR

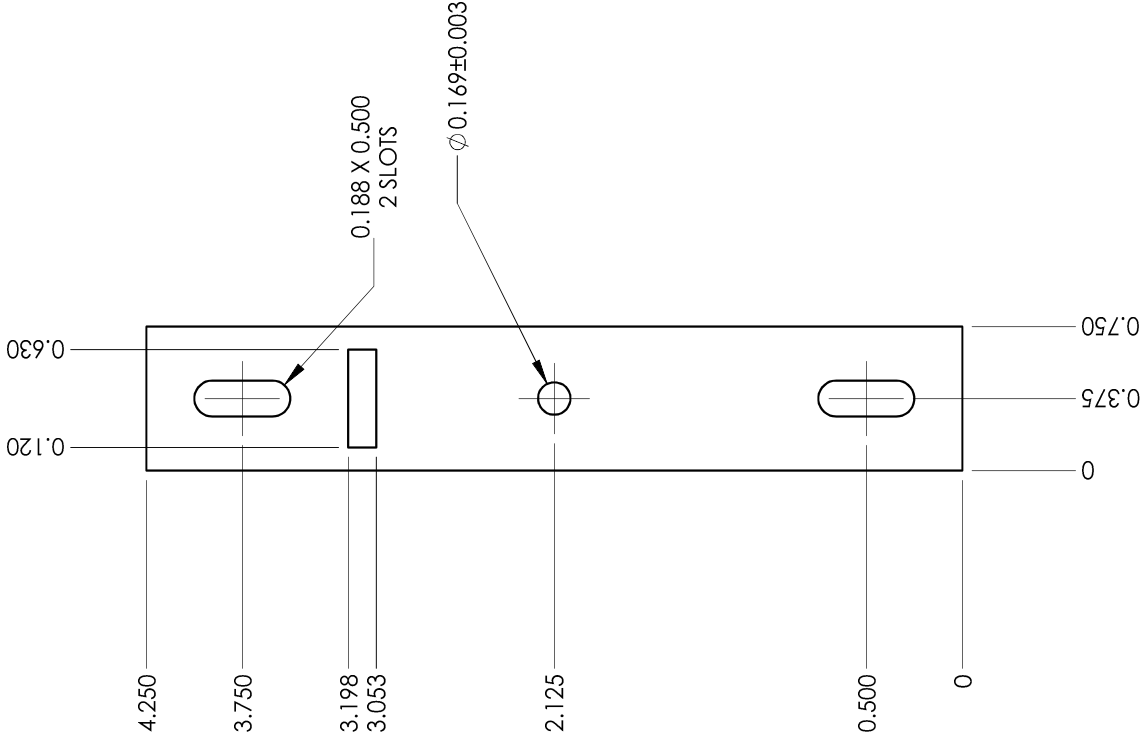

UNLESS OTHERWISE NOTED OR DEPICTED:  
 ALL DIMENSIONS ARE IN INCHES TO 3 DECIMAL PLACES  
 ALL SURFACES ARE CONSIDERED CLASS 'D'  
 REFER TO ENG-009 AND ENG-010  
 FOR SURFACE FINISH CRITERIA

TOLERANCES:  
 FORMED PARTS ±0.001 REFERENCE DIMENSIONS ±0.063  
 BLANKED PARTS ±0.010 ANGLES ±2

02.20.13 AR

**WOLF STEEL**<sup>TM</sup>  
**NAC**  
 NORTH AMERICAN  
 CORPORATION

TITLE:	RETAINER, DOOR ROLLER (REPL W500-0637)	MODEL:	EPI3C	DRAWING:	W500-0750
MATERIAL:	3/16 HR P&O	THICKNESS:	0.188	DRAWN BY:	A.RIGDEN
FINISH:		SCALE:	1:1	SHEET 1 OF 1	9/4/2013
REVISION:	-	WEIGHT:	0.155 LBS	CHECKED BY:	R.TJART

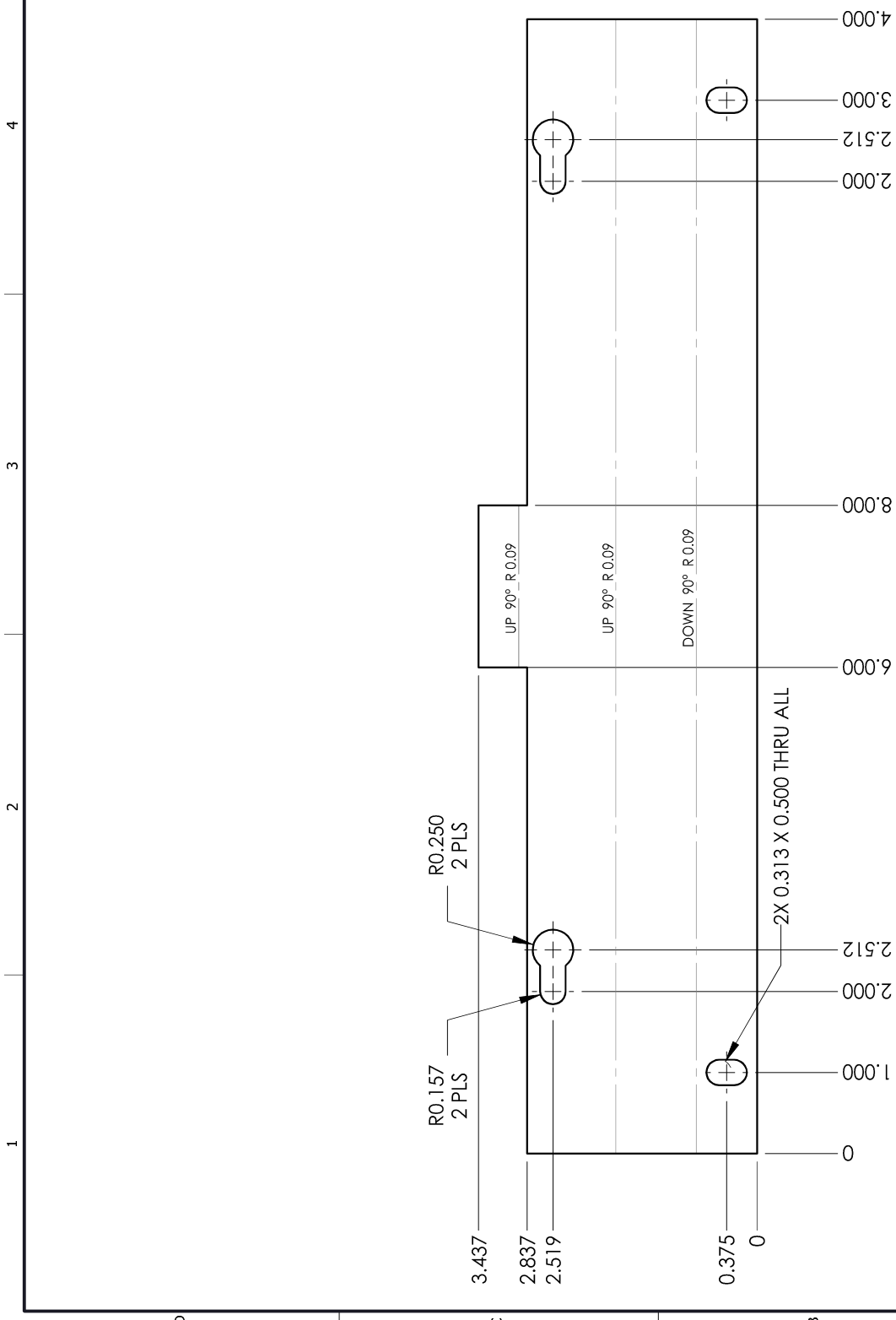

<p>UNLESS OTHERWISE NOTED OR DEPICTED ALL DIMENSIONS ARE OUTSIDE IN INCHES ALL SURFACES ARE CONSIDERED CLASS "D" REFER TO ENG-009 AND ENG-010 FOR SURFACE FINISH CRITERIA</p> <p>TOLERANCES:          FORMED PARTS ±0.031 REFERENCE DIMENSIONS ±0.063          BLANKED PARTS ±0.010 ANGLES ±2</p>		<p>09/14/17 by G.R.</p>	
<p><b>WOLF STEEL</b>  <b>NAC</b>          NORTH AMERICA          4501 S. GARDNER          CHRYSLER, MICHIGAN</p>		<p>09/22/17</p>	
<p>FINISH: HR P&amp;O</p>		<p>REVISION: -</p>	
<p>MATERIAL: 14 GA HR P&amp;O</p>		<p>REV DATE: 09/22/17</p>	
<p>THICKNESS: 0.075</p>		<p>PROJECT LEAD:</p>	
<p>MODEL: W500-0966</p>		<p>CN#:</p>	
<p>EPI3 DRAWING:</p>		<p>SCALE: 1:2</p>	
<p>0.075 DRAWN BY:</p>		<p>SHEET 1 OF 1</p>	
<p>HA</p>		<p>ISSUE DATE: 09/22/17</p>	
<p>CL</p>		<p>CHECKED BY:</p>	

D

C

B

A

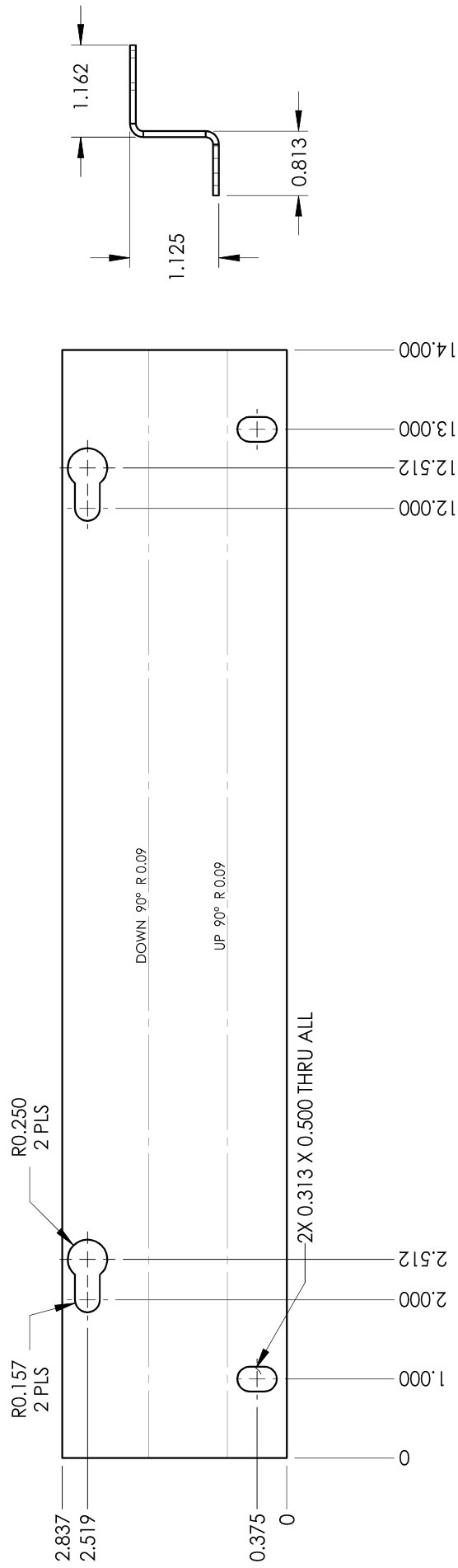

<p>UNLESS OTHERWISE NOTED OR DEPICTED ALL DIMENSIONS ARE OUTSIDE IN INCHES ALL SURFACES ARE CONSIDERED CLASS "D" REFER TO ENG-009 AND ENG-010 FOR SURFACE FINISH CRITERIA</p> <p>TOLERANCES:                  FORMED PARTS ±0.031 REFERENCE DIMENSIONS ±0.063                  BLANKED PARTS ±0.010 ANGLES ±2°</p>		<p>09/14/17 by G.R.</p>
<p><b>WOLF STEEL</b>                  NAC                  NORTH AMERICA                  AUSTRIAN STEEL GROUP</p>	<p>09/14/17 by G.R.</p>	<p>09/28/17</p>
<p>TITLE: <b>RETAINER, CASTING CONTEMP. (RS) (REPLACES W500-0642)</b></p>	<p>MODEL: <b>W500-0967</b></p>	<p>EPI3 DRAWING: <b>W500-0967</b></p>
<p>MATERIAL: 14 GA HR P&amp;O</p>	<p>0.820 LBS THICKNESS:</p>	<p>0.075 DRAWN BY: <b>HA</b></p>
<p>FINISH:</p>	<p>CN#: 1129</p>	<p>SCALE: 1:2</p>
<p>REVISION: -</p>	<p>REV DATE: <b>09/28/17</b></p>	<p>SHEET 1 OF 1</p>
<p>PROJECT LEAD:</p>	<p>ISSUE DATE:</p>	<p>CHECKED BY: <b>CL</b></p>

5

4

3

2

1

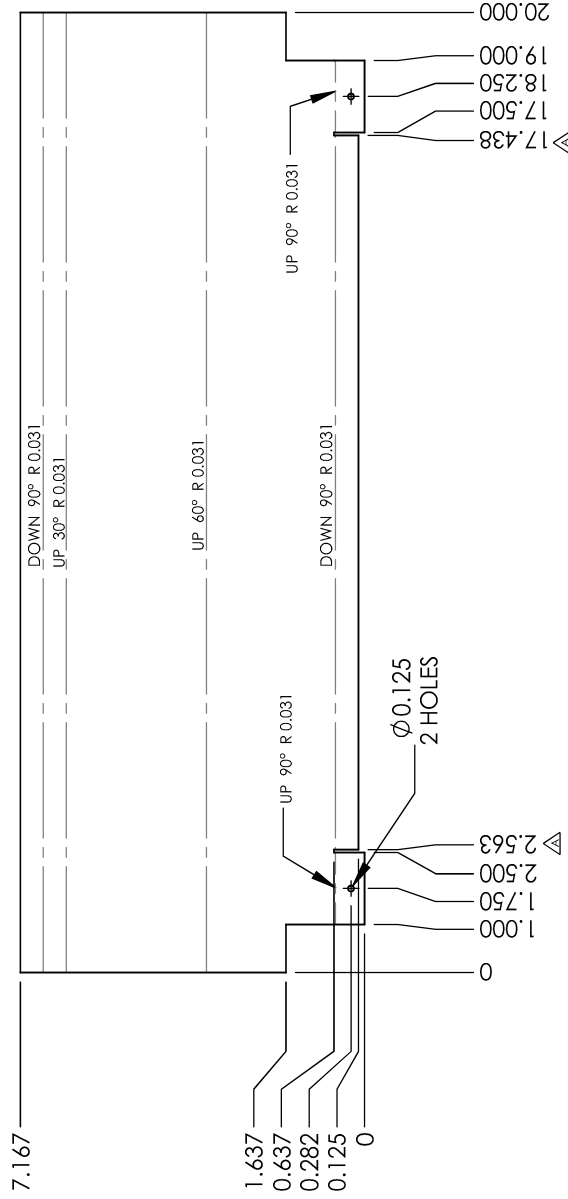
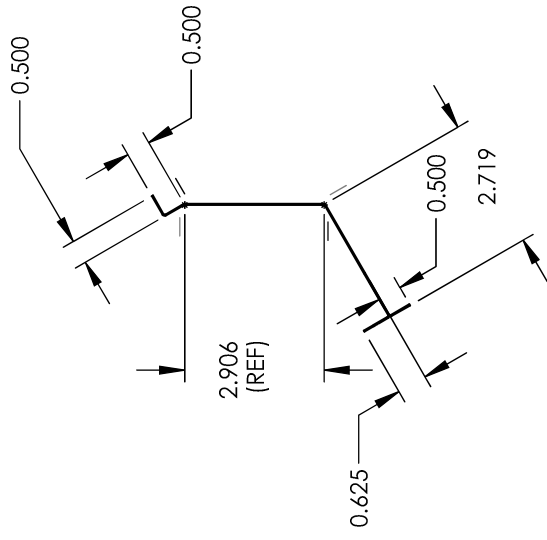

UNLESS OTHERWISE NOTED OR DEPICTED: ALL DIMENSIONS ARE IN INCHES UNLESS NOTED OTHERWISE. ALL SURFACES ARE CONSIDERED CLASS 10 REFER TO ENG-009 AND ENG-010 FOR SURFACE FINISH CRITERIA TOLERANCES: FORMED PARTS: ±0.031 REFERENCE DIMENSIONS ±0.063 BLANKED PARTS: ±0.010 ANGLES ±2°	TITLE: <b>SHEILD, HEAT (BLOWER)</b>	MODEL: EP13	DRAWING: <b>W585-0783</b>
	MATERIAL: 24 GA GALVANNEAL	THICKNESS: 1.060 LBS	DRAWN BY: <b>A.RIGDEN</b>
FINISH:	SCALE: 1:4	SHEET 1 OF 1	MM/DD/YYYY: <b>2/25/2013</b>
REVISION: <b>A</b>	3/28/2013	(AGR) MODIFY DIMS	CHECKED BY: <b>R.TJART</b>



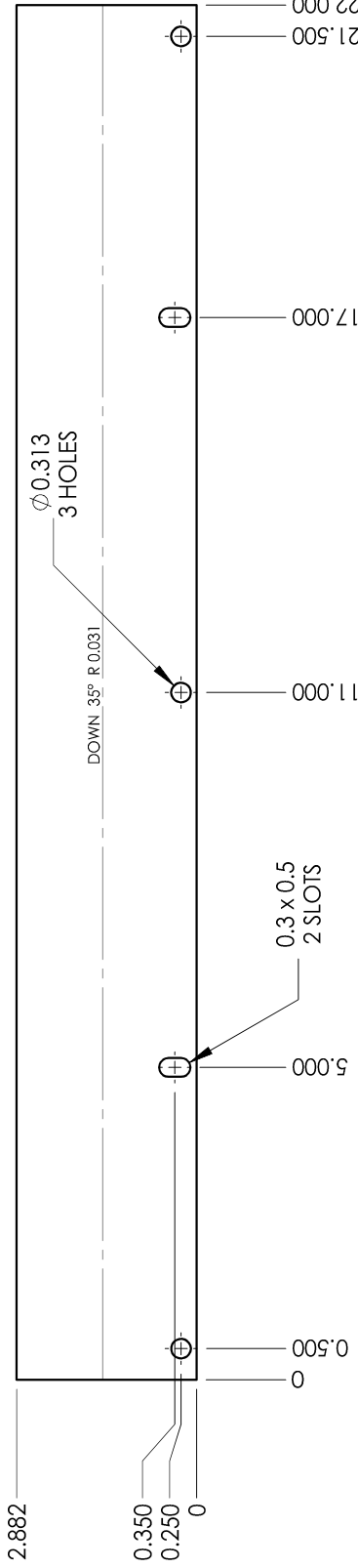
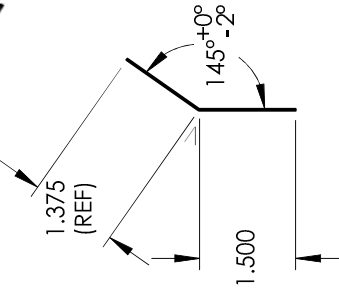
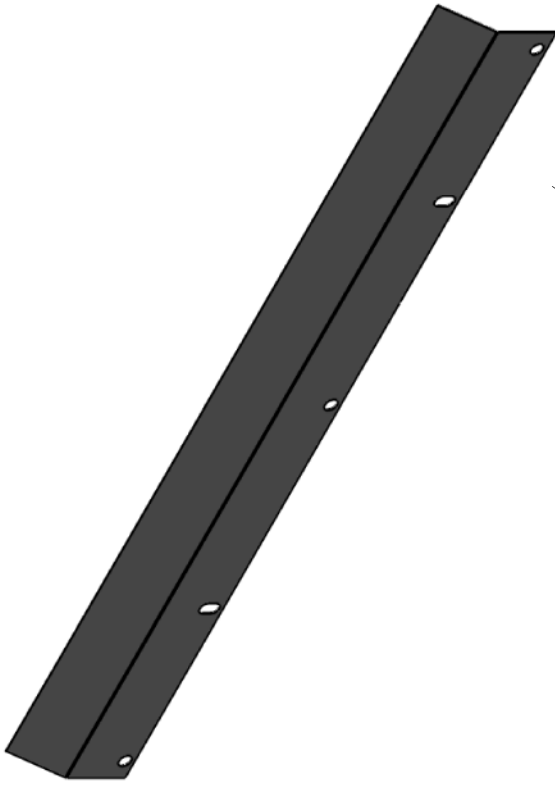

UNLESS OTHERWISE NOTED OR DEPICTED ALL DIMENSIONS ARE OUTSIDE IN INCHES ALL SURFACES ARE CONSIDERED CLASS "D" REFER TO ENG-009 FOR SURFACE FINISH CRITERIA TOLERANCES: FORMED PARTS $\pm 0.031$ REFERENCE DIMENSIONS $\pm 0.063$ BLENDED PARTS $\pm 0.030$ ANGLES $\pm 2$	TITLE: <b>SHEILD, AIRWASH</b>	MODEL: <b>EPI3-1</b>	DRAWING: <b>W585-0794</b>
	MATERIAL: 24 GA SS 304-2B	THICKNESS: 0.455 LBS	ISSUE DATE: 09/29/2009
FINISH:	PROJECT LEAD: P HODGES	SCALE: 1:3	DRAWN BY: UNRELEASED
REVISION: P00	REV DATE: 6/19/2018	REV NOTE:	CHECKED BY: UNRELEASED





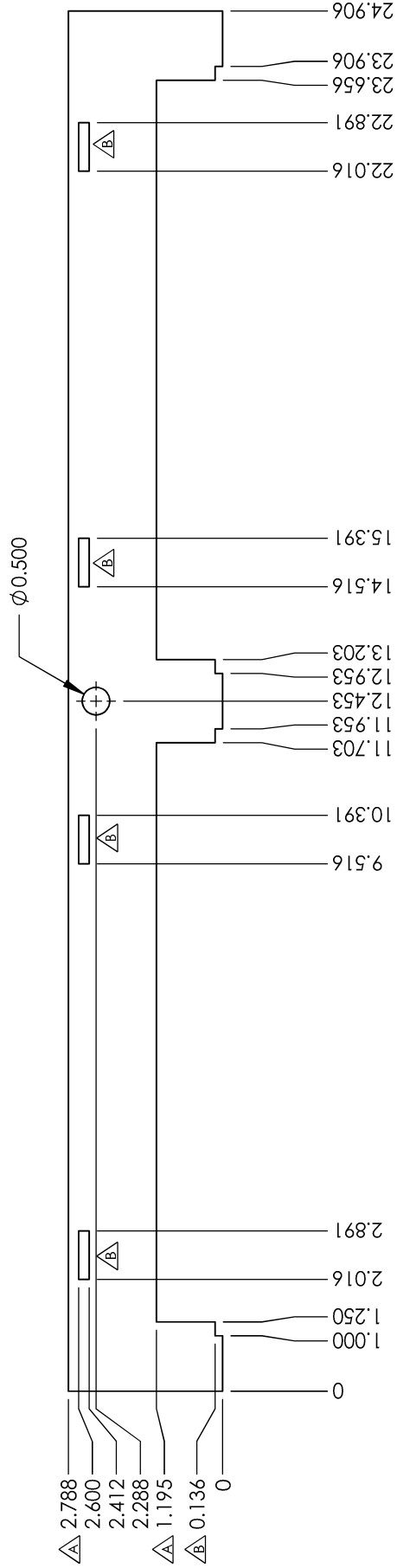

UNLESS OTHERWISE NOTED OR DEPICTED  
 ALL DIMENSIONS ARE OUTSIDE IN INCHES  
 UNLESS OTHERWISE NOTED  
 WHERE APPLICABLE FLAT IS SHOWN FINISHED SIDE UP

TOLERANCES:  
 FORMED PARTS ±0.031"  
 BURNED PARTS ±0.063"  
 SURFACE DIMENSIONS ±.2°  
 ANGLES



**WOLF STEEL**<sup>TM</sup>  
**NAC**  
 NAC Steel  
 A Division of  
 Nucor Corporation

TITLE:	<b>STIFFENER, FIREBOX TOP</b>	MODEL:	EP13	DRAWING:	<b>W655-0404</b>
MATERIAL:	3/16 HR P&O	THICKNESS:	0.188	DRAWN BY:	<b>A.RIGDEN</b>
FINISH:		SCALE:	1:3	SHEET 1 OF 1	<b>6/13/2012</b>
REVISION:	<b>B</b>	(AGR) ADD SLOTS/MODIFY DIM		CHECKED BY:	<b>R.TJART</b>

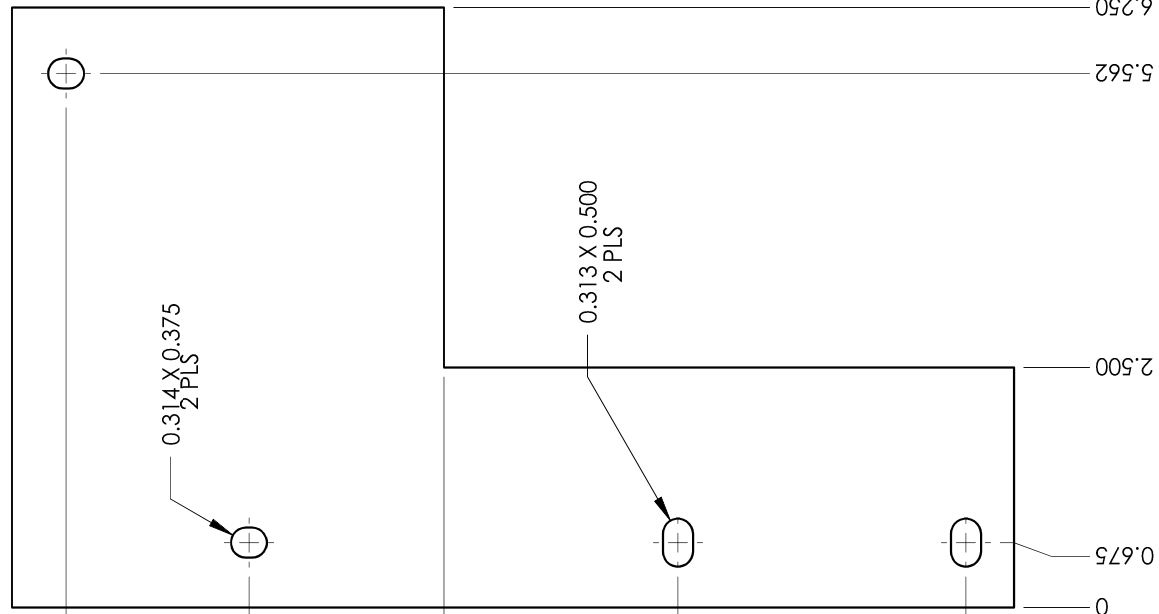

10.438  
9.875  
7.970  
5.938  
3.501  
0.501  
0

<p>UNLESS OTHERWISE NOTED OR DEPICTED ALL DIMENSIONS ARE OUTSIDE IN INCHES ALL SURFACES ARE CONSIDERED CLASS "D" REFER TO ENG-009 AND ENG-010 FOR SURFACE FINISH CRITERIA</p>		<p>TITLE: <b>SUPPORT, CASTING (UPPER CORNER) (REPLACES W655-0427)</b></p>		<p>MODEL: <b>EPI3</b></p>		<p>DRAWING: <b>W655-0899</b></p>	
<p>FORMED PARTS ±0.031 REFERENCE DIMENSIONS ±0.063 BLANKED PARTS ±0.010 ANGLES ±2</p>		<p>MATERIAL: 14 GA HR P&amp;O</p>		<p>THICKNESS: 0.075</p>		<p>DRAWN BY: <b>HA</b></p>	
<p>FINISH:</p>		<p>PROJECT LEAD:</p>		<p>SCALE: 1:2</p>		<p>ISSUE DATE:</p>	
<p>REVISION: -</p>		<p>REV/DATE: <b>09/28/17</b></p>		<p>SHEET 1 OF 1</p>		<p>CHECKED BY: <b>CL</b></p>	

09/14/17 by G.R.

**WOLF STEEL**<sup>TM</sup>  
 NAC  
 NORTH AMERICAN  
 CASTING CORPORATION

D C B A

D C B A

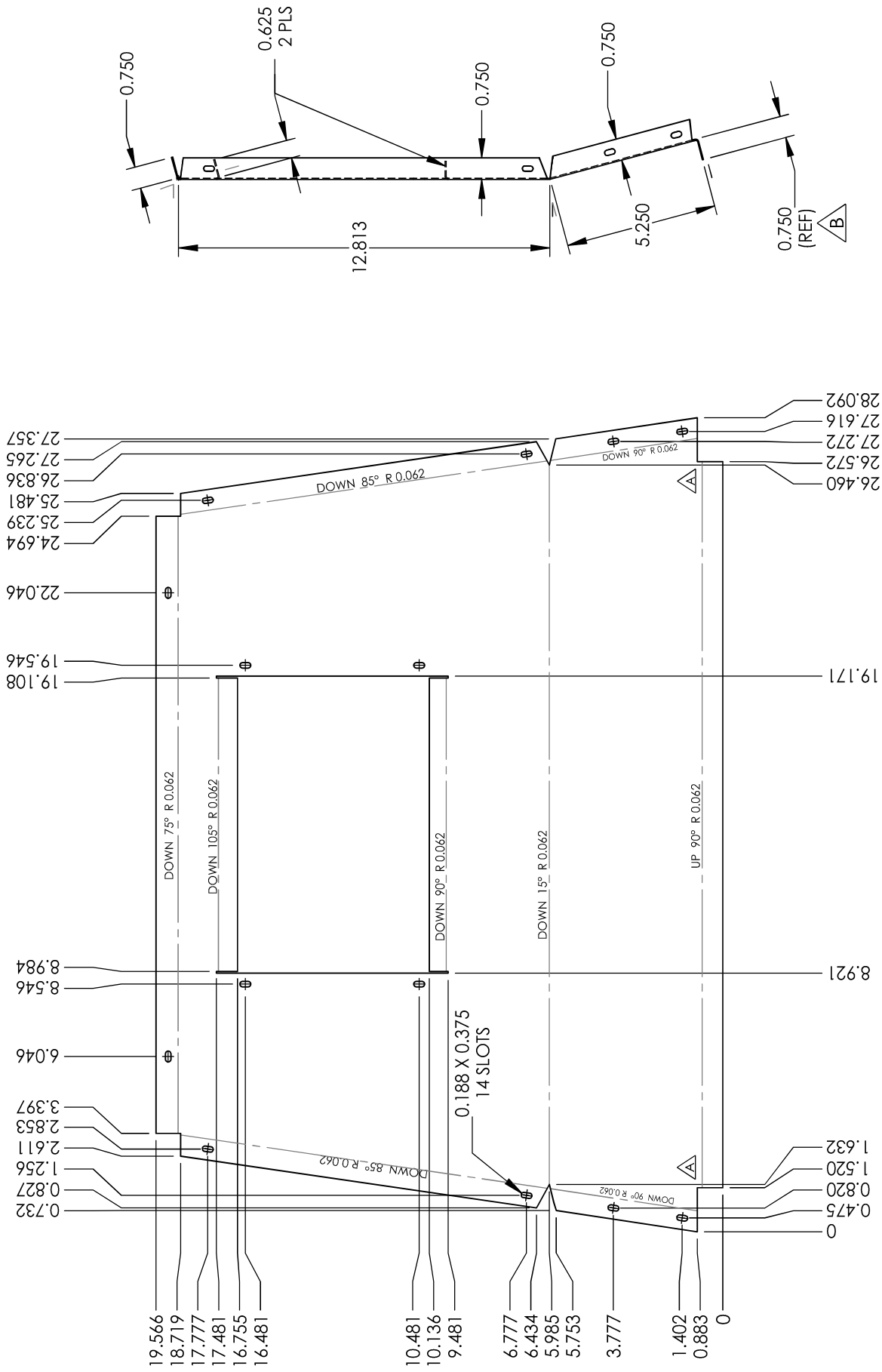

<p>UNLESS OTHERWISE NOTED OR DEPICTED ALL DIMENSIONS ARE OUTSIDE IN INCHES</p> <p>WHERE APPLICABLE, FLAT IS SHOWN FINISHED SIDE UP</p> <p>FORMED PARTS ±0.031" BLANKED PARTS ±0.010" REFERENCE DIMENSIONS ±0.063" ANGLES ±2°</p>	<p>TITLE: <b>TOP, OUTER SHELL</b></p>	<p>MODEL: EP13</p>	<p>DRAWING: <b>W705-0264</b></p>
	<p>MATERIAL: 20 GA GALVANNEAL</p>	<p>THICKNESS: 0.039</p>	<p>DRAWN BY: <b>A.RIGDEN</b></p>
<p>FINISH:</p>	<p>WEIGHT: 4.711 LBS</p>	<p>SCALE: 1:5</p>	<p>SHEET 1 OF 1</p>
<p>REVISION: <b>B</b></p>	<p>DATE: <b>9/10/2013</b></p>	<p>(AGR) FIX DIM</p>	<p>CHECKED BY: <b>R.TJART</b></p>



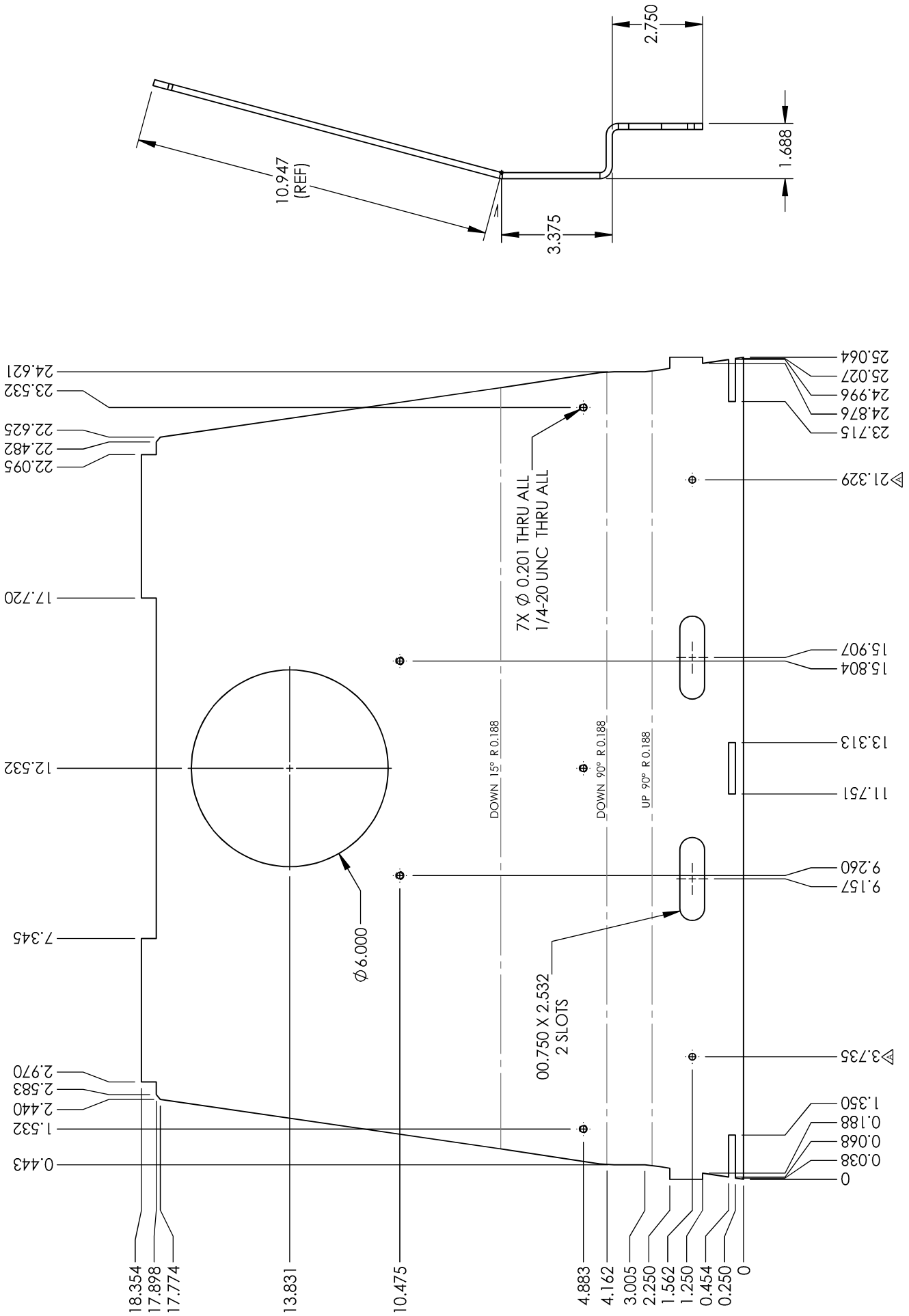

UNLESS OTHERWISE NOTED OR DEPICTED ALL DIMENSIONS ARE OUTSIDE IN INCHES WHERE APPLICABLE FLAT IS SHOWN FINISHED SIDE UP TOLERANCES: FORMED PARTS ±0.031" BEADED PARTS ±0.063" SURFACE DIMENSIONS ±2° ANGLES		TITLE: <b>TOP, FIREBOX</b> MATERIAL: 3/16 HR P&O FINISH: REVISION: <b>A</b>	MODEL: EPT3 THICKNESS: 0.188 SCALE: 1:4	DRAWING: <b>W705-0276</b> DRAWN BY: <b>A.RIGDEN</b> SHEET 1 OF 1 CHECKED BY:
TOP, FIREBOX MATERIAL: 3/16 HR P&O FINISH: REVISION: <b>A</b>		MODEL: EPT3 THICKNESS: 0.188 SCALE: 1:4	DRAWING: <b>W705-0276</b> DRAWN BY: <b>A.RIGDEN</b> SHEET 1 OF 1 CHECKED BY:	20.016 LBS 1/30/2013 (AGR) MOVE HOLES 6/13/2012

**NOTE: PART MUST BE FREE OF BURRS**

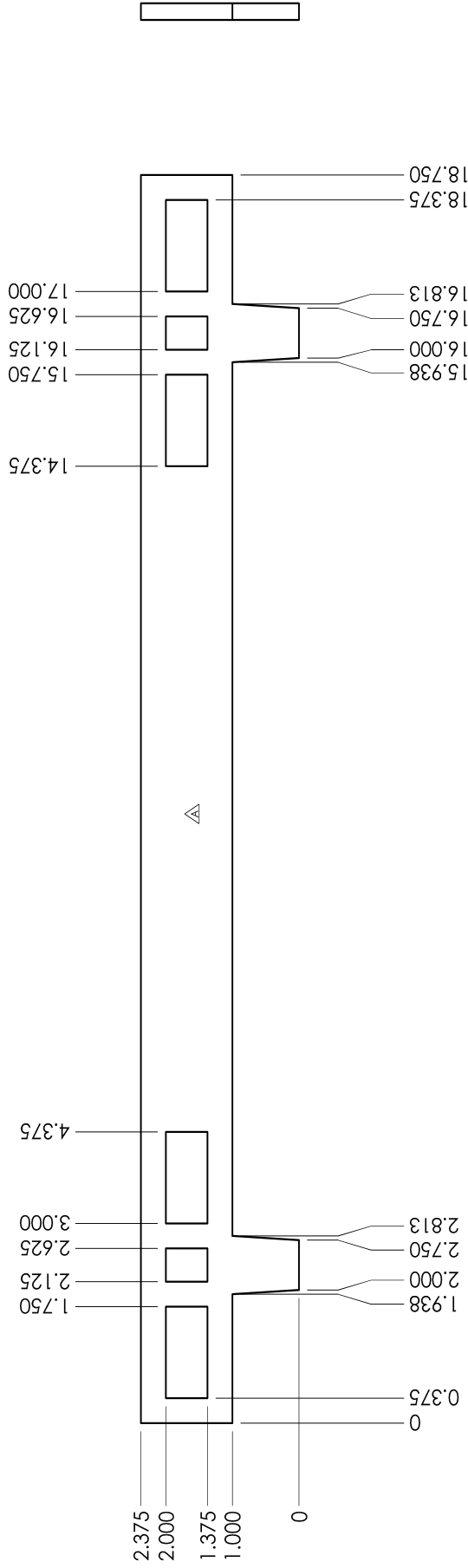

UNLESS OTHERWISE NOTED OR DEPICTED: ALL DIMENSIONS ARE TO BE HONED TO CLASS "D" ALL SURFACES ARE CONSIDERED CLASS "D" REFER TO ENG-009 AND ENG-010 FOR SURFACE FINISH CRITERIA TOLERANCES: FORMED PARTS: ±0.031 REFERENCE DIMENSIONS ±0.063 BLANKED PARTS: ±0.010 ANGLES ±2°	TITLE: <b>TRIM, LOG RETAINER</b>	MODEL: EP13	DRAWING: <b>W715-0916</b>
	MATERIAL: 1/4 HR P&O	THICKNESS: 1.645 LBS	DRAWN BY: <b>A.RIGDEN</b>
FINISH:	SCALE: 1:2.5	SHEET 1 OF 1	CHECKED BY: <b>R.TJART</b>
REVISION: <b>A</b>	2/25/2013	(AGR) REMOVE CENTRE SLOT	

This drawing is the property of Wolf Steel Ltd. or NAC.  
 It is to be used only for the specific part identified  
 without our consent. All rights are reserved.

**WOLF STEEL™**  
**NAC**  
 Product of  
 Canada

02.20.13 AR

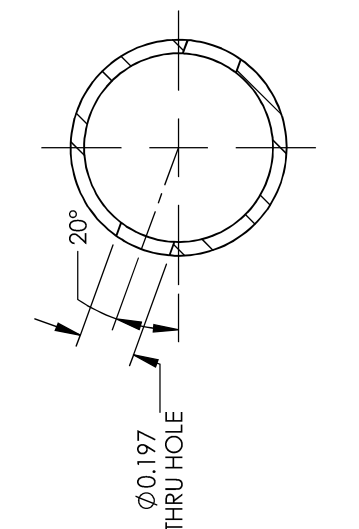
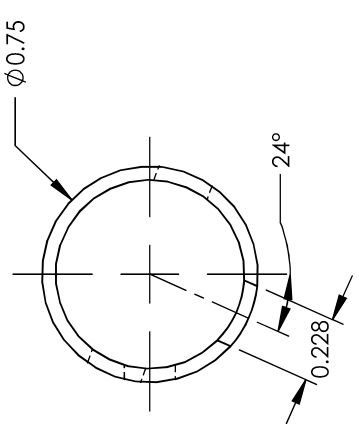
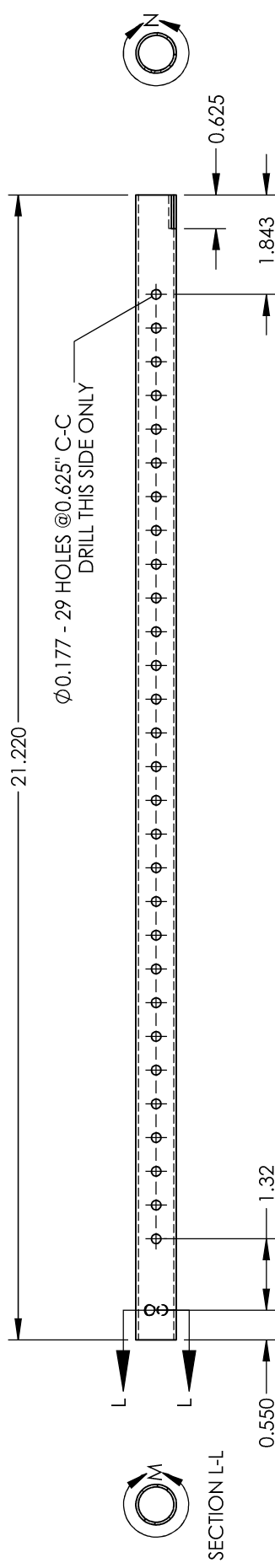

This drawing is the property of Wolf Steel Ltd. or NCC. It is not to be used in any manner without our consent. All rights are reserved.		TITLE: <b>TUBE, SECONDARY AIR #1</b>		MODEL: EPI3-1	DRAWING: <b>W720-0191</b>
		MATERIAL: 18 GA 1.20mm Tubing SS 430-2b		THICKNESS: 0.63 LBS	ISSUE DATE: <b>UNRELEASED</b>
UNLESS OTHERWISE NOTED OR DEPICTED ALL DIMENSIONS ARE OUTSIDE IN INCHES ALL SURFACES ARE CONSIDERED CLASS "D"		FINISH:	PROJECT LEAD: P HODGES	SCALE: 1:3	SHEET 1 OF 1
DIMENSIONS ±0.031 REFERENCE DIMENSIONS ±0.062		TOLERANCES:	REV DATE:	REV NOTE:	CHECKED BY: <b>UNRELEASED</b>
RADIUS ±0.062 ANGLES ±2		DATE FORWAT: MM/DD/YY	REVISION:	CN#:	DRAWN BY: <b>MS</b>
<b>WOLF STEEL™</b>		1	2	3	4
10/27/17 BY G		5	6	7	8





D

C

B

A

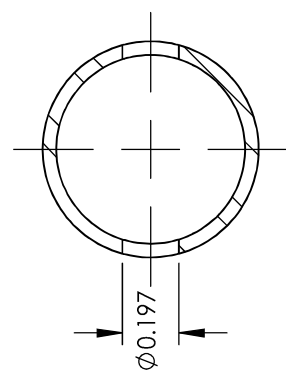
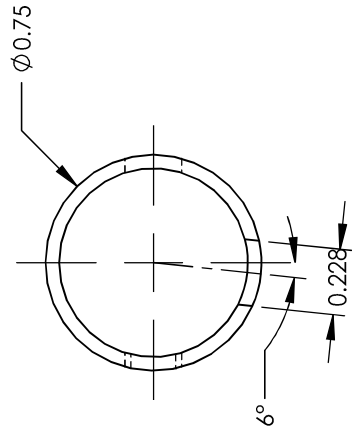
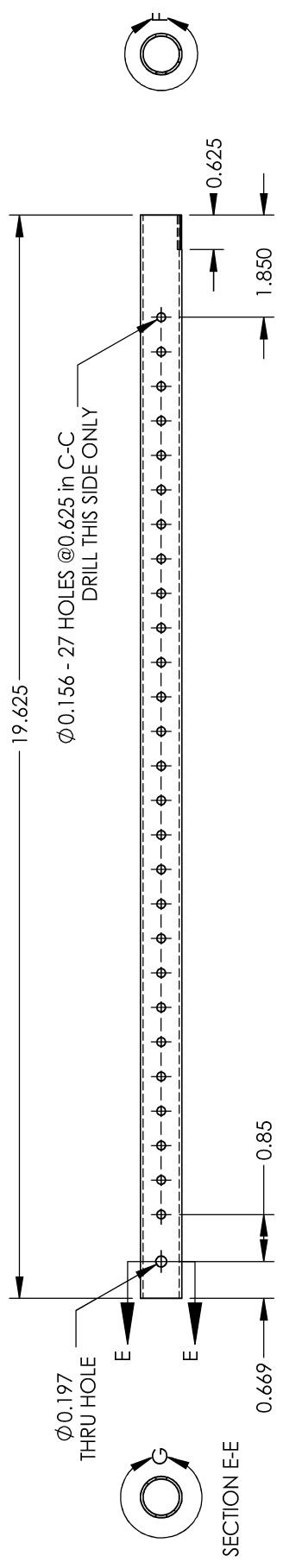

This drawing is the property of Wolf Steel Ltd. or NCC. It is not to be used in any manner without our consent. All rights are reserved.		UNLESS OTHERWISE NOTED OR DEPICTED ALL DIMENSIONS ARE OUTSIDE IN INCHES ALL SURFACES ARE CONSIDERED CLASS "D"		DIMENSIONS ±0.031 REFERENCE DIMENSIONS ±0.062		TITLE: <b>TUBE, SECONDARY AIR #3</b>	MODEL: EPI3-1	DRAWING: <b>W720-0193</b>
		MATERIAL: 18GA, 1.20mm Tubing SS 430-2b		FINISH:		THICKNESS: 0.58 LBS	SCALE: 1:3	ISSUE DATE: <b>UNRELEASED</b>
TOLERANCES: DIMENSIONS ±0.031 REFERENCE DIMENSIONS ±0.062		PROJECT LEAD: P HODGES	CN#:	SHEET 1 OF 1	DRAWN BY: <b>MS</b>	CHECKED BY: <b>UNRELEASED</b>	SCALE: 1.5 : 1	DRAWING: <b>W720-0193</b>
DATE FOR WAVE: MM/DD/YY		REVISION:	REV DATE:	REV NOTE:	1	2	3	4
WOLF STEEL™		120617 BY G		5	5	5	5	5

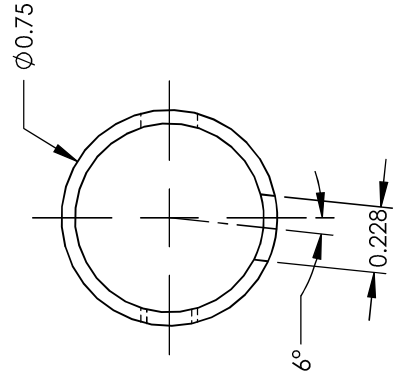
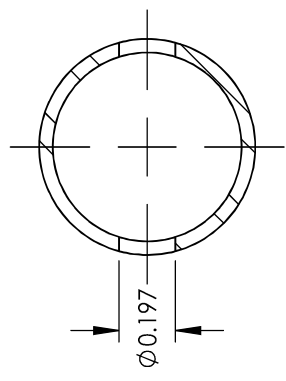
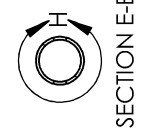
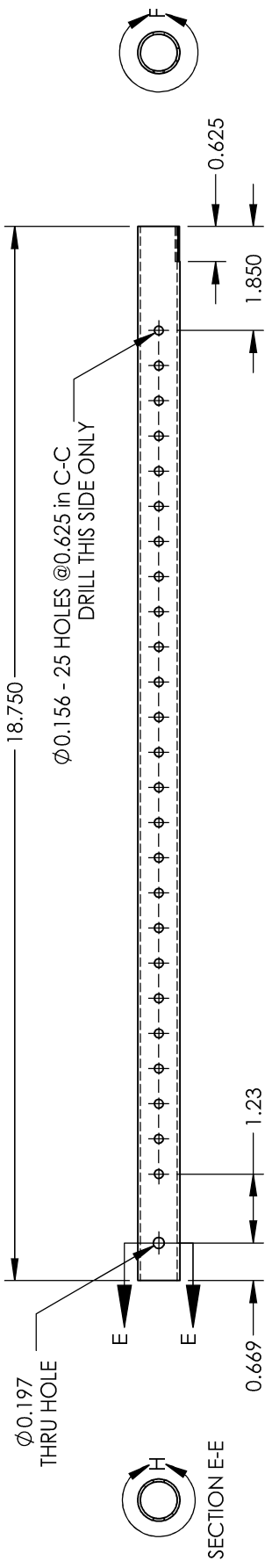

UNLESS OTHERWISE NOTED OR DEPICTED ALL DIMENSIONS ARE OUTSIDE IN INCHES ALL SURFACES ARE CONSIDERED CLASS "D"	TITLE: <b>TUBE, SECONDARY AIR #4</b>		MODEL: EPI3-1	DRAWING: <b>W720-0194</b>
	MATERIAL: 18 GA, 1.20mm Tubing SS 430-2b		THICKNESS: 0.56 LBS	ISSUE DATE: UNRELEASED
DIMENSIONS $\pm 0.031$ REFERENCE DIMENSIONS $\pm 0.062$	FINISH:	PROJECT LEAD: P HODGES	SCALE: 1:3	SHEET 1 OF 1
TOLERANCES: DIMENSIONS $\pm 0.031$ REFERENCE DIMENSIONS $\pm 0.062$	REVISION:	REV DATE:	REV NOTE:	DRAWN BY: MS CHECKED BY: UNRELEASED

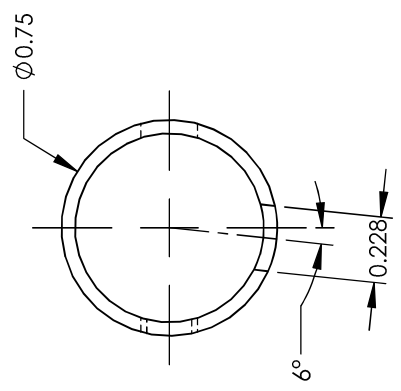
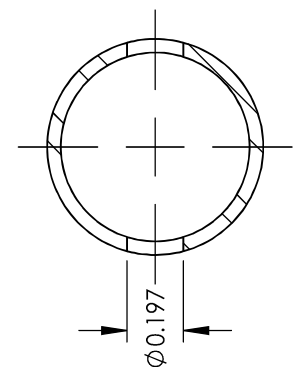
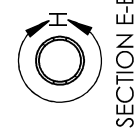
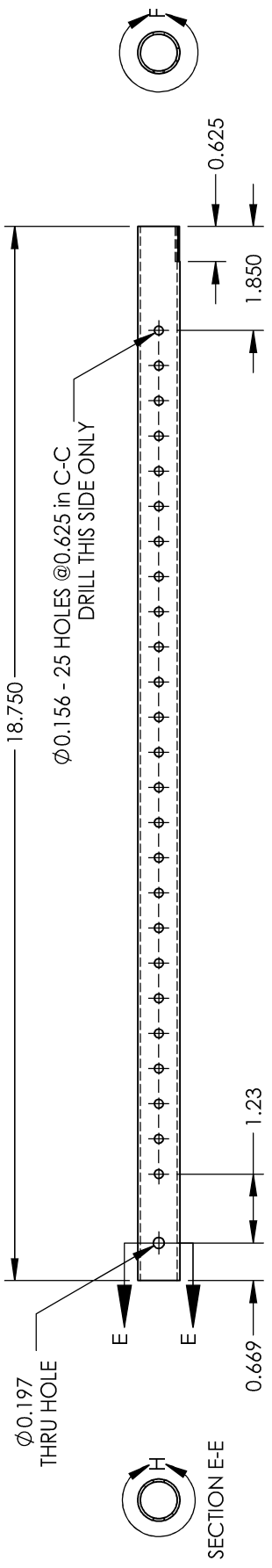

<small>This drawing is the property of Wolf Steel Ltd. or NCC. It is not to be used in any manner without our consent. All rights are reserved.</small> <b>WOLF STEEL™</b>	 <small>UNLESS OTHERWISE NOTED OR DEPICTED ALL DIMENSIONS ARE OUTSIDE IN INCHES ALL SURFACES ARE CONSIDERED CLASS "D"</small>	<b>TITLE:</b> TUBE, SECONDARY AIR #4 <b>MATERIAL:</b> 18 GA, 1.20mm Tubing SS 430-2b <b>FINISH:</b> <b>REVISION:</b> <b>REV DATE:</b>	<b>MODEL:</b> EPI3-1 <b>THICKNESS:</b> 0.56 LBS <b>CN#:</b>	<b>DRAWING:</b> W720-0194 <b>ISSUE DATE:</b> UNRELEASED <b>DRAWN BY:</b> MS <b>CHECKED BY:</b> UNRELEASED
	<small>TOLERANCES:          DIMENSIONS ±0.031          REFERENCE DIMENSIONS ±0.062          RADIUS ±0.062          ANGLES ±2</small>	<b>PROJECT LEAD:</b> P HODGES <b>REV NOTE:</b>	<b>SCALE:</b> 1:3 <b>SHEET 1 OF 1</b>	<b>5</b>

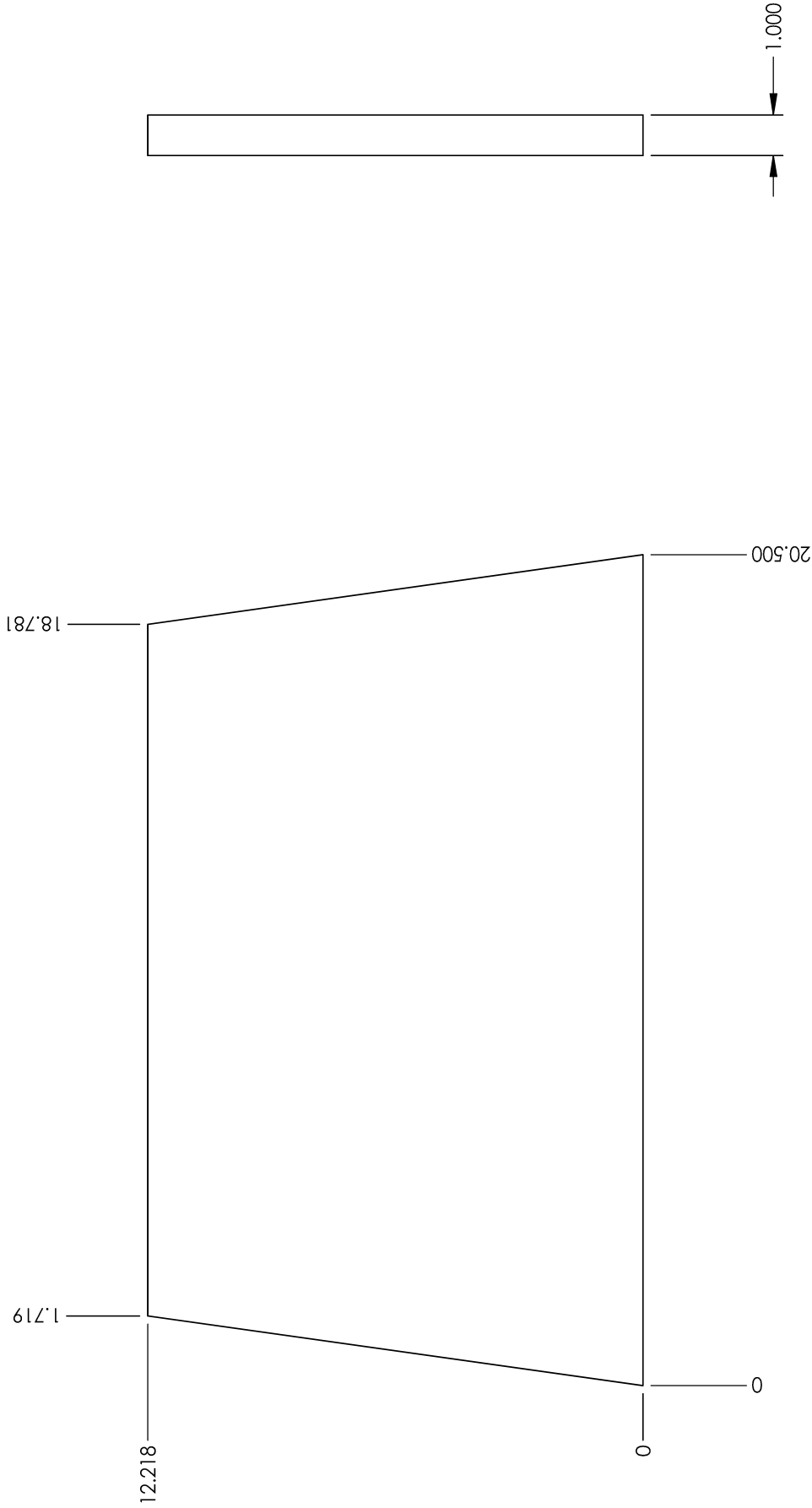

This drawing is the property of Wolf Steel LTD. or NAC. It is to be used only for the project and without our consent. All rights are reserved.

**WOLF STEEL<sup>TM</sup>**  
**NAC** Export Sales  
 America  
 Corporation

01/09/12 AR

**UNLESS OTHERWISE NOTED OR DEPICTED  
 ALL DIMENSIONS ARE OUTSIDE IN INCHES  
 ALL SURFACES ARE CONSIDERED CLASS 10<sup>th</sup>**

**TOLERANCES:**  
 DIMENSIONS ±0.003"  
 REFERENCE DIMENSIONS ±0.125"  
 ANGLES ±2°

**TITLE: BAFFLE, FIREBOX**

**MATERIAL: VERMICULITE V-1100°C (700)**

**FINISH:**

**REVISION: -**

<b>MODEL:</b>	EPT3	<b>DRAWING:</b>	W018-0133
	5.803 LBS	<b>DRAWN BY:</b>	A.RIGDEN
	SHEET 1 OF 1	<b>MM/DD/YYYY:</b>	6/13/2012
	SCALE: 1:4	<b>CHECKED BY:</b>	R.TJART

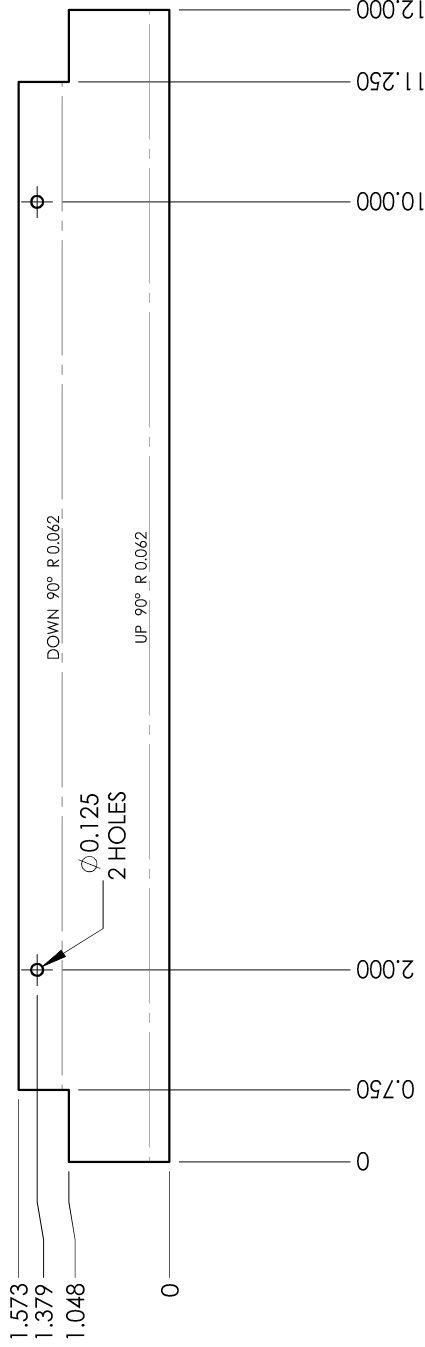
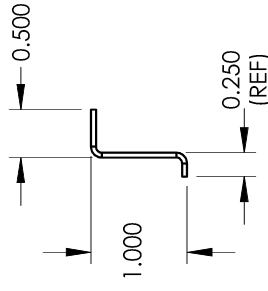

UNLESS OTHERWISE NOTED OR DEPICTED:  
ALL DIMENSIONS ARE IN INCHES UNLESS NOTED OTHERWISE  
ALL SURFACES ARE CONSIDERED CLASS 'D'  
REFER TO ENG-009 AND ENG-010  
FOR SURFACE FINISH CRITERIA

TOLERANCES:  
FORMED PARTS ±0.031 REFERENCE DIMENSIONS ±0.063  
BLANKED PARTS ±0.010 ANGLES ±2

**WOLF STEEL**<sup>TM</sup>  
**NAC**  
 NORTH AMERICAN  
 CORRUGATED  
 COMPANY

TITLE:	<b>BAFFLE, REAR AIR</b>	MODEL:	EP13	DRAWING:	<b>W018-0145</b>
MATERIAL:	18 GA GALVANNEAL	THICKNESS:	0.051	DRAWN BY:	<b>A.RIGDEN</b>
FINISH:		SCALE:	1:2	SHEET 1 OF 1	<b>2/25/2013</b>
REVISION:	~	CHECKED BY:			<b>R.TJART</b>

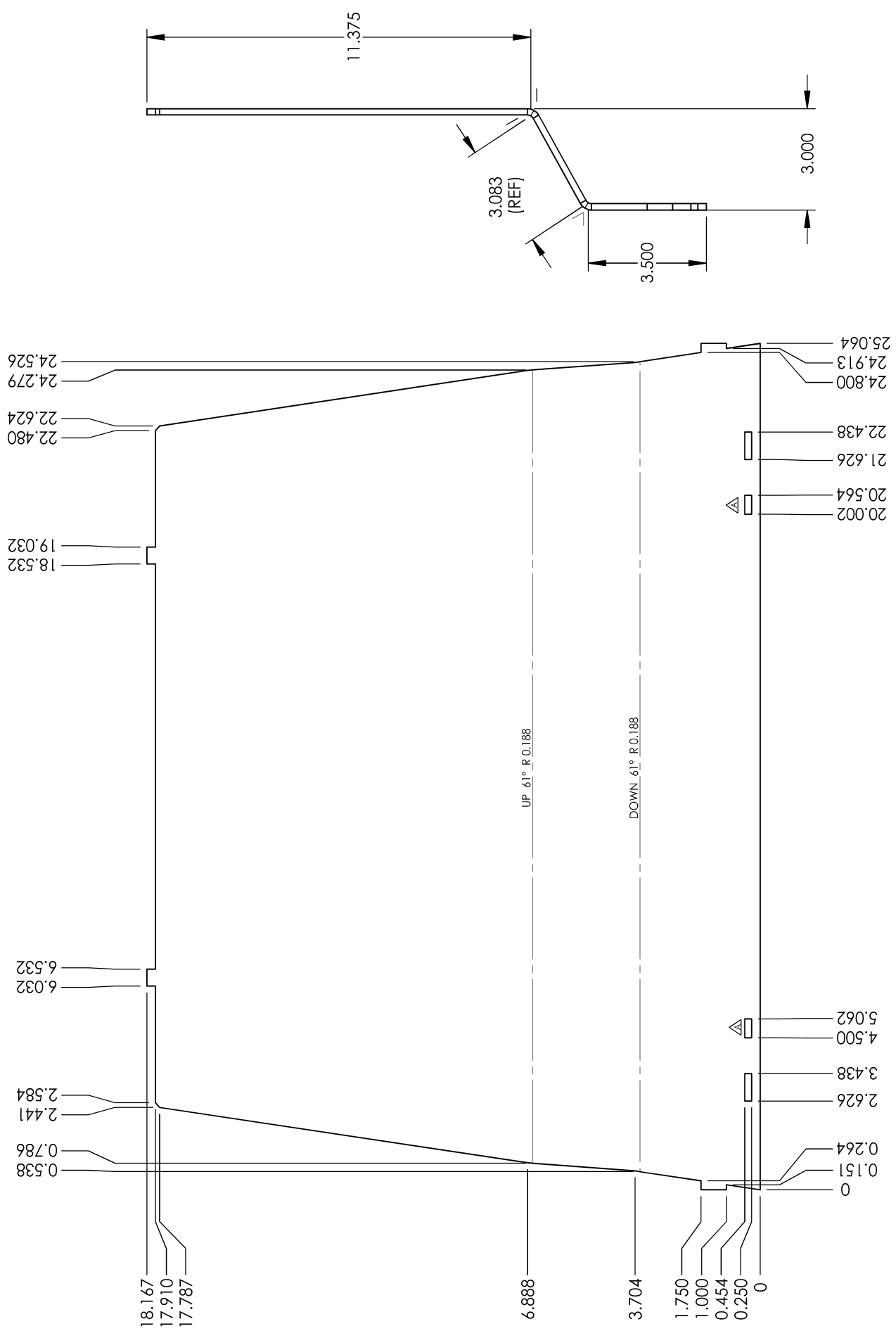

<p><small>This drawing is the property of Wolf Steel LTD. or NAC. It is not to be reproduced, stored in a retrieval system, or transmitted in any form or by any means, without our consent. All rights are reserved.</small></p> <p><b>WOLF STEEL™</b></p> <p><b>NAC</b></p> <p><small>Manufactured in Canada</small></p>		<p><b>UNLESS OTHERWISE NOTED OR DEPICTED ALL DIMENSIONS ARE OUTSIDE IN INCHES</b></p> <p><b>TOLERANCES:</b></p> <p>WHERE APPLICABLE, FLAT IS SHOWN FINISHED SIDE UP</p> <p>FORMED PARTS ±0.031"          BLANKED PARTS ±0.010"          REFERENCE DIMENSIONS ±0.063"          ANGLES ±2°</p>		<p><b>TITLE:</b> BASE, FIREBOX</p> <p><b>MATERIAL:</b> 3/16 HR P&amp;O</p> <p><b>FINISH:</b></p>	<p><b>MODEL:</b> EP13</p> <p><b>THICKNESS:</b> 0.188</p> <p><b>SCALE:</b> 1:4</p>	<p><b>DRAWING:</b> W035-0287</p> <p><b>DRAWN BY:</b> A.RIGDEN</p> <p><b>SHEET 1 OF 1</b></p>	<p><b>DATE:</b> 2/11/2013</p> <p><b>REVISION:</b> A</p>	<p><b>DATE:</b> 6/13/2012</p> <p><b>CHECKED BY:</b> R.TJART</p>
		<p><b>WEIGHT:</b> 21.541 LBS</p>		<p><b>THICKNESS:</b> 0.188</p>		<p><b>SCALE:</b> 1:4</p>		
		<p><b>DESCRIPTION:</b> (AGR) ADD SLOTS</p>						

NOTES:

- 1 PART IS NOT SYMMETRICAL  $\triangle B$
- 2 FORM PART TO DRAWING REGARDLESS OF BUR DIRECTION

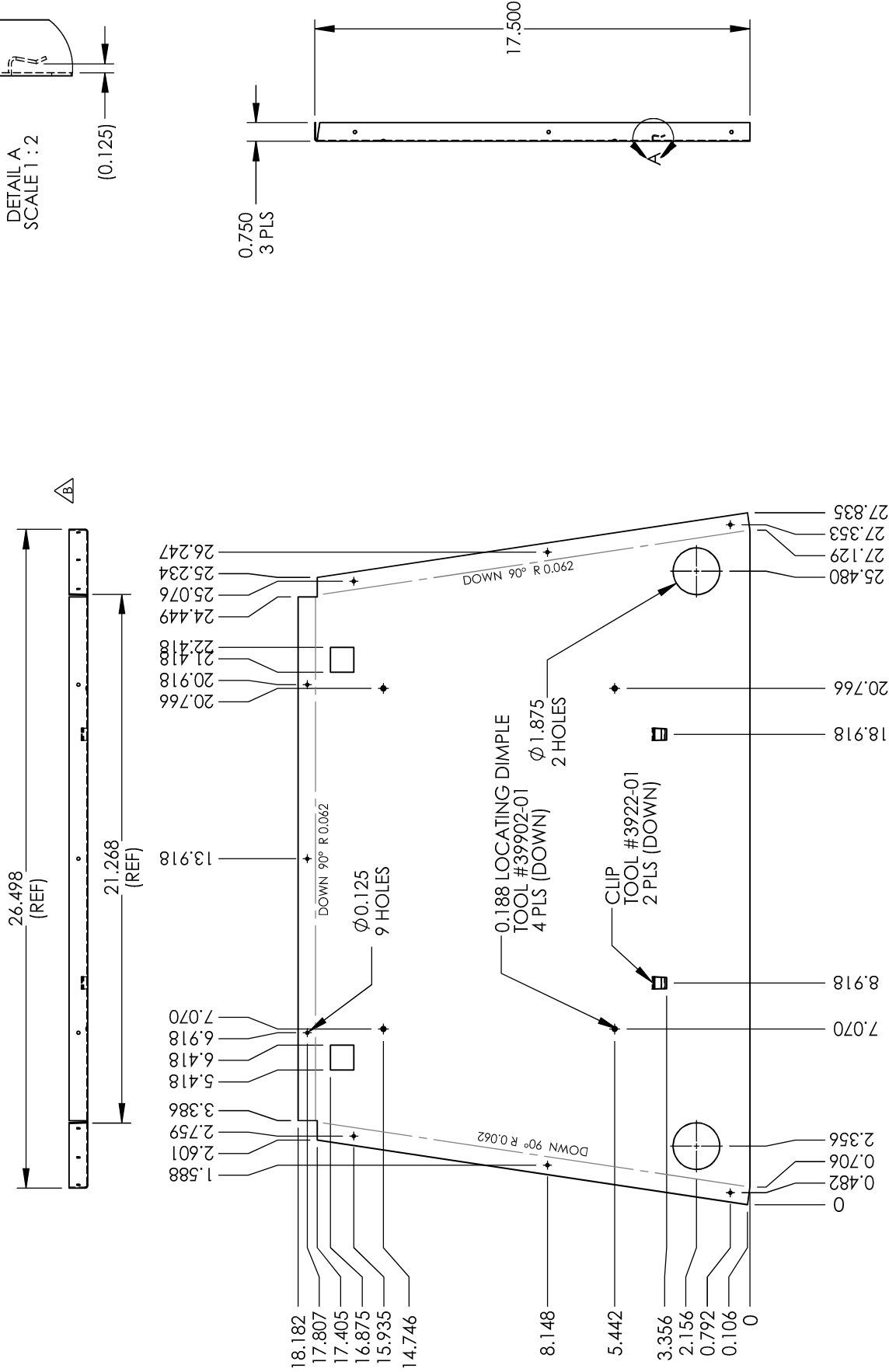

UNLESS OTHERWISE NOTED OR DEPICTED ALL DIMENSIONS ARE OUTSIDE IN INCHES ALL SURFACES ARE CONSIDERED CLASS "D" REFER TO ENG-009 AND ENG-010 FOR SURFACE FINISH CRITERIA	TITLE: <b>BASE, OUTER SHELL</b>	MODEL:	EPI3 DRAWING: <b>W035-0288</b>
	MATERIAL: 20 GA GALVANNEAL	THICKNESS: 0.039	DRAWN BY: <b>A.RIGDEN</b>
FINISH:	REVISION: <b>B</b>	SCALE: 1:6	SHEET 1 OF 1
TOLERANCES: FORMED PARTS ±0.031 REFERENCE DIMENSIONS ±0.003 BLANKED PARTS ±0.010 ANGLES ±2°	MM/DD/YY: <b>10/30/2015</b> (AGR) ADD VIEW/ADD NOTES	CHECKED BY:	6/13/2012
08/27/15 AGR	1	4	5

**NOTE:**

1. DEBUR ALL EDGES
2. DIMENSIONAL TOLERANCES APPLY  $\triangle$  AFTER DEBUR

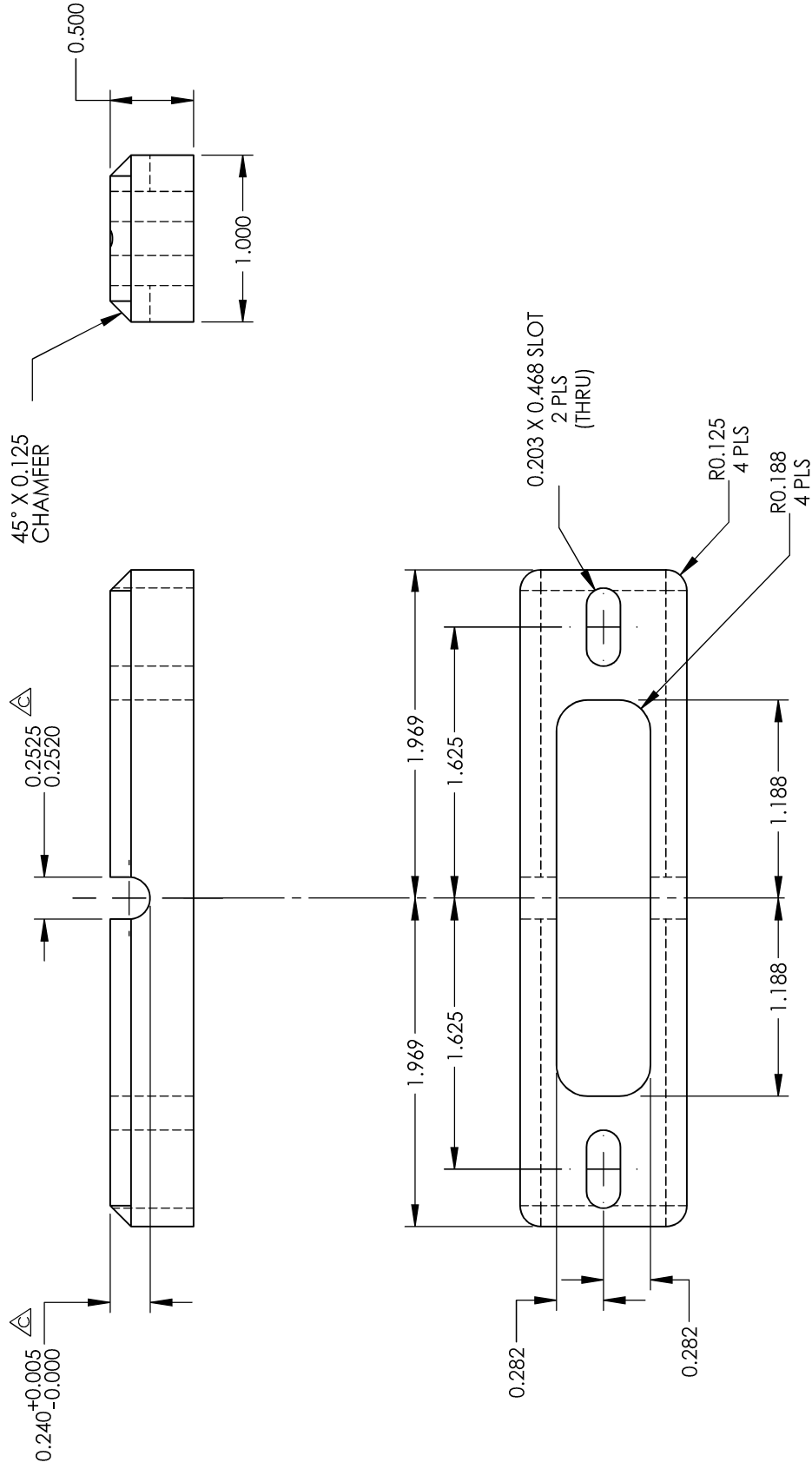

<p>UNLESS OTHERWISE NOTED OR DEPICTED ALL DIMENSIONS ARE OUTSIDE IN INCHES ALL SURFACES ARE CONSIDERED CLASS "B"</p> <p>TOLERANCES: DIMENSIONS <math>\pm 0.005"</math> ANGLES <math>\pm 1^\circ</math></p>	TITLE:	<b>BLOCK, LATCH PIN</b>	MODEL:	EPI3T	DRAWING:	<b>W060-0011</b>
	MATERIAL:	CRS		0.318 LBS	DRAWN BY:	<b>A.RIGDEN</b>
	FINISH:	BLACK OXIDE		SHEET 1 OF 1	MM/DD/YYYY:	<b>6/13/2012</b>
	REVISION:	<b>C</b>	<b>5/23/2013</b>	(AGR) MODIFY DIMS/ADD NOTE	CHECKED BY:	<b>R.TJART</b>

The drawing is the property of Wolf Steel Ltd. or NAC. It is to be used only for the project and for the quantity specified. All rights are reserved.

**WOLF STEEL**<sup>TM</sup>  
**NAC**  
NORTH AMERICAN  
CORPORATION

10/09/12 AR



NOTE: BREAK ALL EDGES

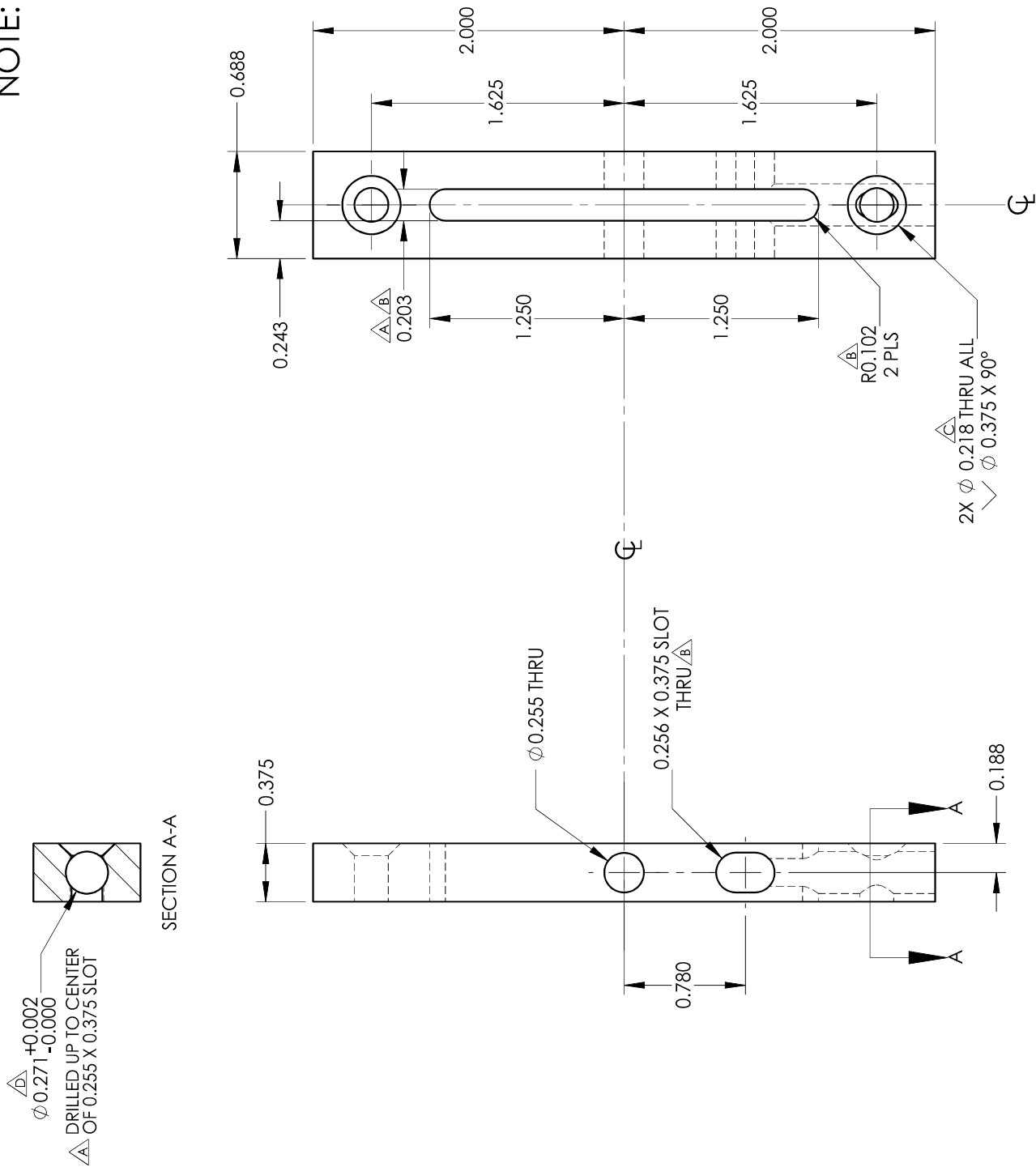

$\Delta$   $\phi$  0.271  $\begin{matrix} +0.002 \\ -0.000 \end{matrix}$   
 DRILLED UP TO CENTER  
 OF 0.255 X 0.375 SLOT

SECTION A-A

UNLESS OTHERWISE NOTED OR DEPICTED ALL DIMENSIONS ARE OUTSIDE IN INCHES ALL SURFACES ARE CONSIDERED CLASS 10  DIMENSIONS $\pm 0.005"$ ANGLES $\pm 1$  <b>TOLERANCES:</b>	TITLE:	<b>BLOCK, DOOR LATCH</b>	MODEL:	S4	DRAWING:	<b>W060-0012</b>
	MATERIAL:	CRS		0.200 LBS	DRAWN BY:	<b>J.DUCHESNE</b>
	FINISH:	BLACK OXIDE		SHEET 1 OF 1	MM/DD/YYYY:	<b>10/30/2012</b>
	REVISION:	<b>D</b>	<b>6/27/2013</b>	(JMD) REVISED HOLE DIAMETER	CHECKED BY:	<b>R.TJART</b>

The drawing is the property of Wolf Steel LTD., or NAC.  
 It is to be used only for the project and for the quantity  
 specified on the drawing. All rights are reserved.

**WOLF STEEL**<sup>TM</sup>  
**NAC**  
 Precision in  
 Architecture  
 Construction

10/09/12 AR

Thread Size 5/16" - 18  
 Width (A) 0.625"  
 Thickness (B) 0.139"  
 Length of Leg from End to Angle (C) 0.985"  
 (C1) 0.985"  
 Centre of Hole to Angle (D) 0.609"  
 Pilot Diameter (E) 0.349"  
 Pilot Height (F) 0.08"  
 Projection Width (G) 0.136"  
 Projection Height (H) 0.022"  
 Projection Length (I) 0.126"  
 Material High-Welding Quality,  
 Low Carbon Steel  
 Finish Plain  
 Threads Unified Standard Class 2B

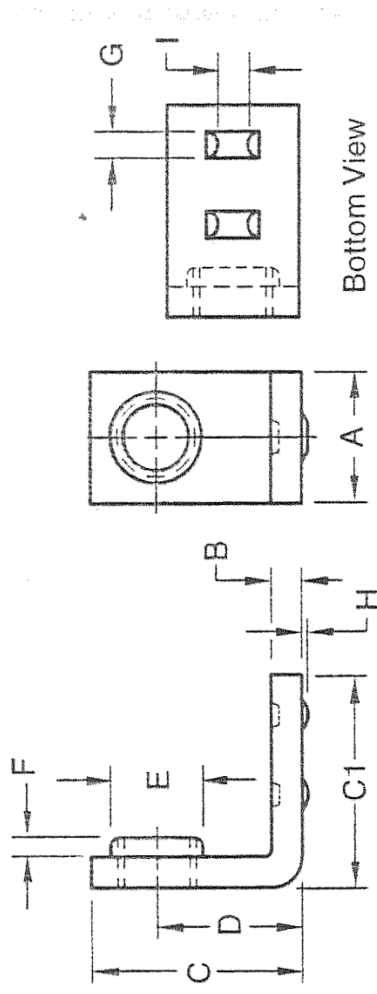

WOLF STEEL LTD

DIMS: INCHES

TITLE: BRACKET, 5/16-18 x 5/8"

DWG#: W080-0209

REV:

DATE: 06.15.11\_JFK

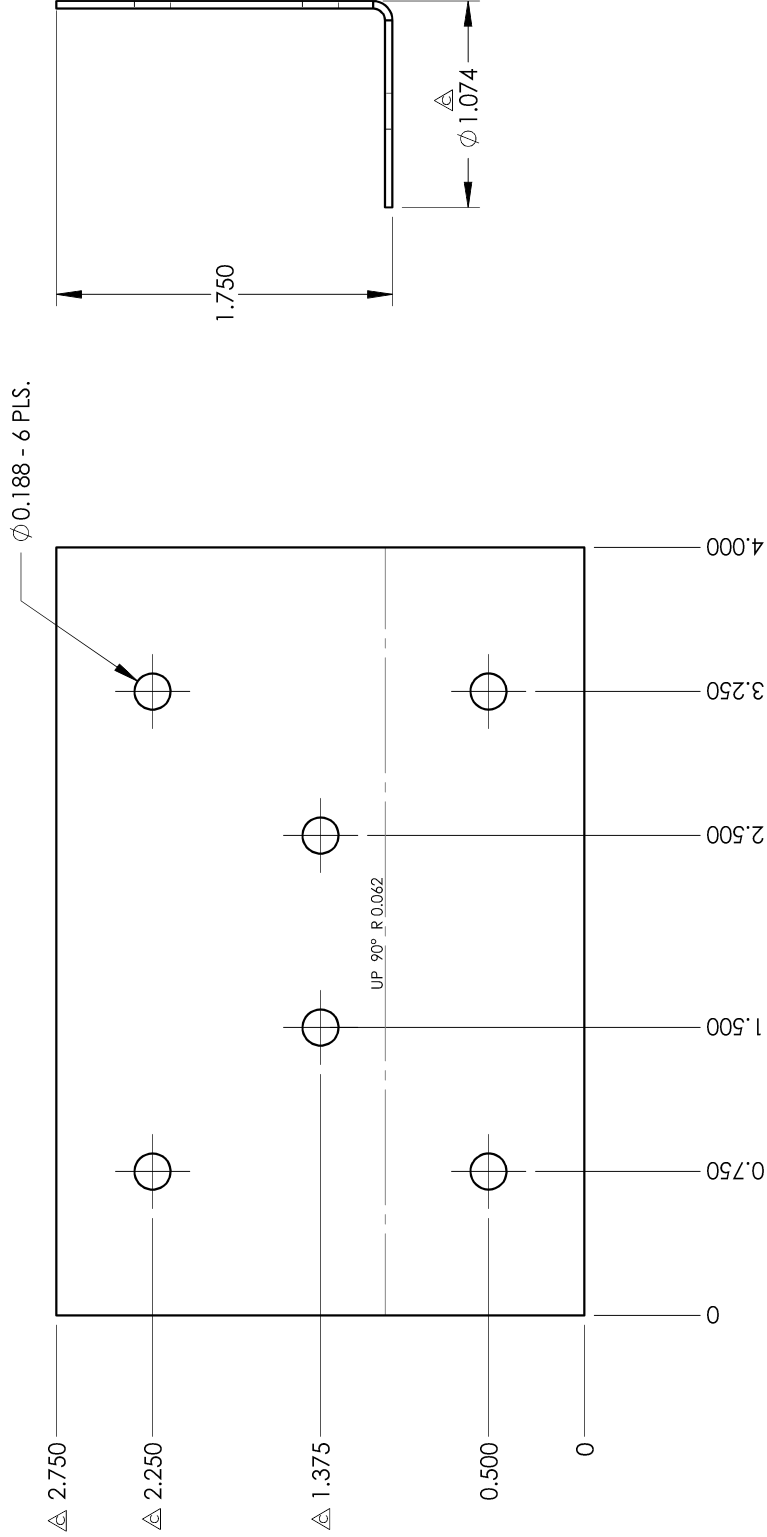

UNLESS OTHERWISE NOTED OR DEPICTED ALL DIMENSIONS ARE OUTSIDE IN INCHES WHERE APPLICABLE. FLAT IS SHOWN FINISHED SIDE UP TOLERANCES: FORMED PARTS ±0.031" BURNED PARTS ±0.063" SURFACE DIMENSIONS ±.2° ANGLES	TITLE:	<b>BRACKET, SHIPPING</b>	
	MATERIAL:	20 GA	GALVANNEAL
	FINISH:		
	REVISION:	<b>C</b>	<b>12/3/2015</b> (JDP) MODIFY DIMS/HOLE POSITIONS
	TITLE:	<b>BRACKET, SHIPPING</b>	
	MATERIAL:	20 GA	GALVANNEAL
	FINISH:		
	REVISION:	<b>C</b>	<b>12/3/2015</b> (JDP) MODIFY DIMS/HOLE POSITIONS
	MODEL:	0.120 LBS	
	THICKNESS:	0.039	
	SCALE:	1:1	SHEET 1 OF 1
	DRAWING:	<b>W080-0245</b>	
	DRAWN BY:	JTA	
	MM/DD/YYYY:	7/20/1994	
	CHECKED BY:	R.TJART	

This drawing is the property of Wolf Steel LTD., or NAC.  
 It is to be used only for the project and order number  
 specified on the drawing. All rights are reserved.

**WOLF STEEL**<sup>TM</sup>  
**NAC**  
 PROJECT HEADQUARTERS  
 10109 12 AR

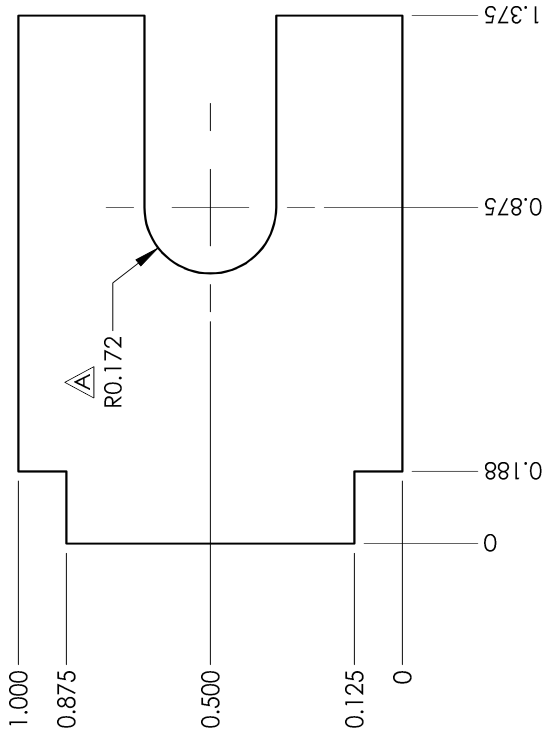

<p>UNLESS OTHERWISE NOTED OR DEPICTED ALL DIMENSIONS ARE OUTSIDE IN INCHES</p> <p>TOLERANCES: WHERE APPLICABLE, FLAT IS SHOWN FINISHED SIDE UP</p> <p>FORMED PARTS ±0.031" BLANKED PARTS ±0.010" REFERENCE DIMENSIONS ±0.063" ANGLES ±2°</p>	<p>TITLE: <b>BRACKET, CASTING MOUNT</b></p>	<p>MODEL: EP13</p>	<p>DRAWING: <b>W080-1161</b></p>
	<p>MATERIAL: 3/16 HR P&amp;O</p>	<p>THICKNESS: 0.059 LBS</p>	<p>DRAWN BY: <b>A.RIGDEN</b></p>
	<p>FINISH:</p>	<p>SCALE: 2:1</p>	<p>MM/DD/YYYY: <b>06/13/12</b></p>
	<p>REVISION: <b>A</b> 06/12/17 (RB) INCREASED SLOT DIA</p>	<p>CHECKED BY:</p>	<p>CLIFF</p>



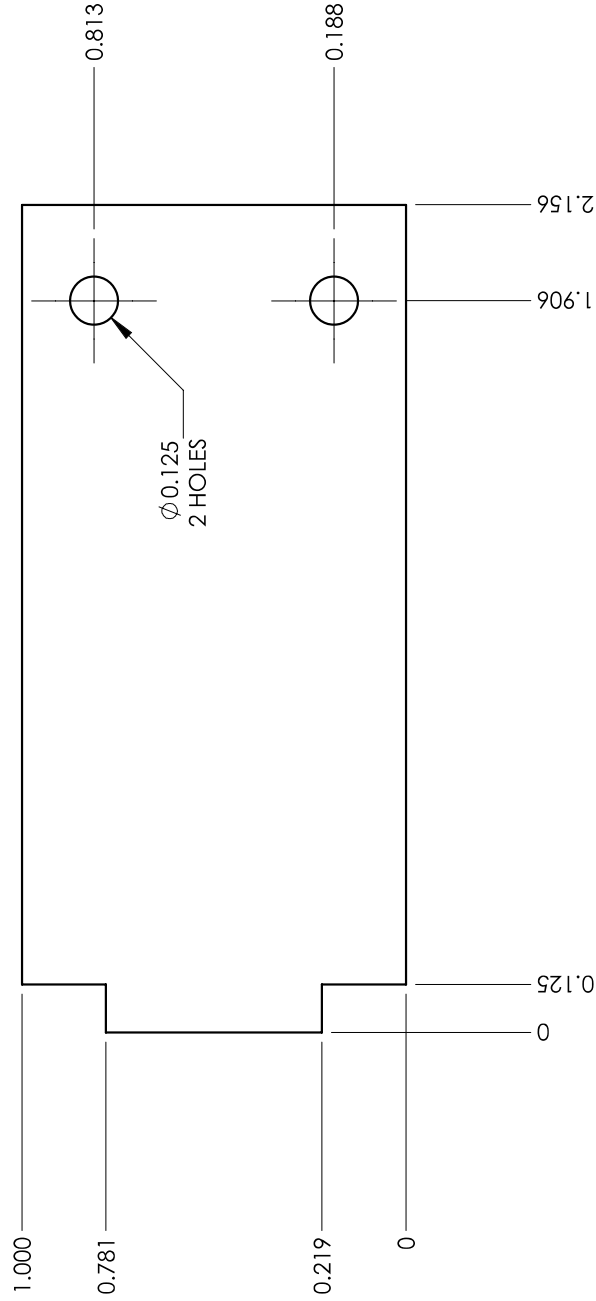

<p>UNLESS OTHERWISE NOTED OR DEPICTED ALL DIMENSIONS ARE OUTSIDE IN INCHES</p>		<p>TITLE: <b>BRACKET, AIR CONTROL</b></p>		<p>MODEL: EP13</p>		<p>DRAWING: <b>W080-1176</b></p>	
<p>WHERE APPLICABLE, FLAT IS SHOWN FINISHED SIDE UP</p>		<p>MATERIAL: 14 GA HR P&amp;O</p>		<p>THICKNESS: 0.044 LBS</p>		<p>DRAWN BY: <b>A.RIGDEN</b></p>	
<p>FORMED PARTS ±0.031" BLANKED PARTS ±0.010" REFERENCE DIMENSIONS ±0.063" ANGLES ±2°</p>		<p>FINISH:</p>		<p>SCALE: 2:1</p>		<p>MM/DD/YYYY: <b>06/13/12</b></p>	
<p>REVISION: -</p>		<p>FINISH:</p>		<p>SHEET 1 OF 1</p>		<p>CHECKED BY: <b>R.TJART</b></p>	

**WOLF STEEL**  
 NAC  
 Napoleon  
 American  
 Corporation

This drawing is the property of Wolf Steel Ltd., or NAC.  
 It is to be used only for the project and order  
 number shown hereon. No part of this drawing  
 may be reproduced or transmitted in any form  
 without our consent. All rights are reserved.

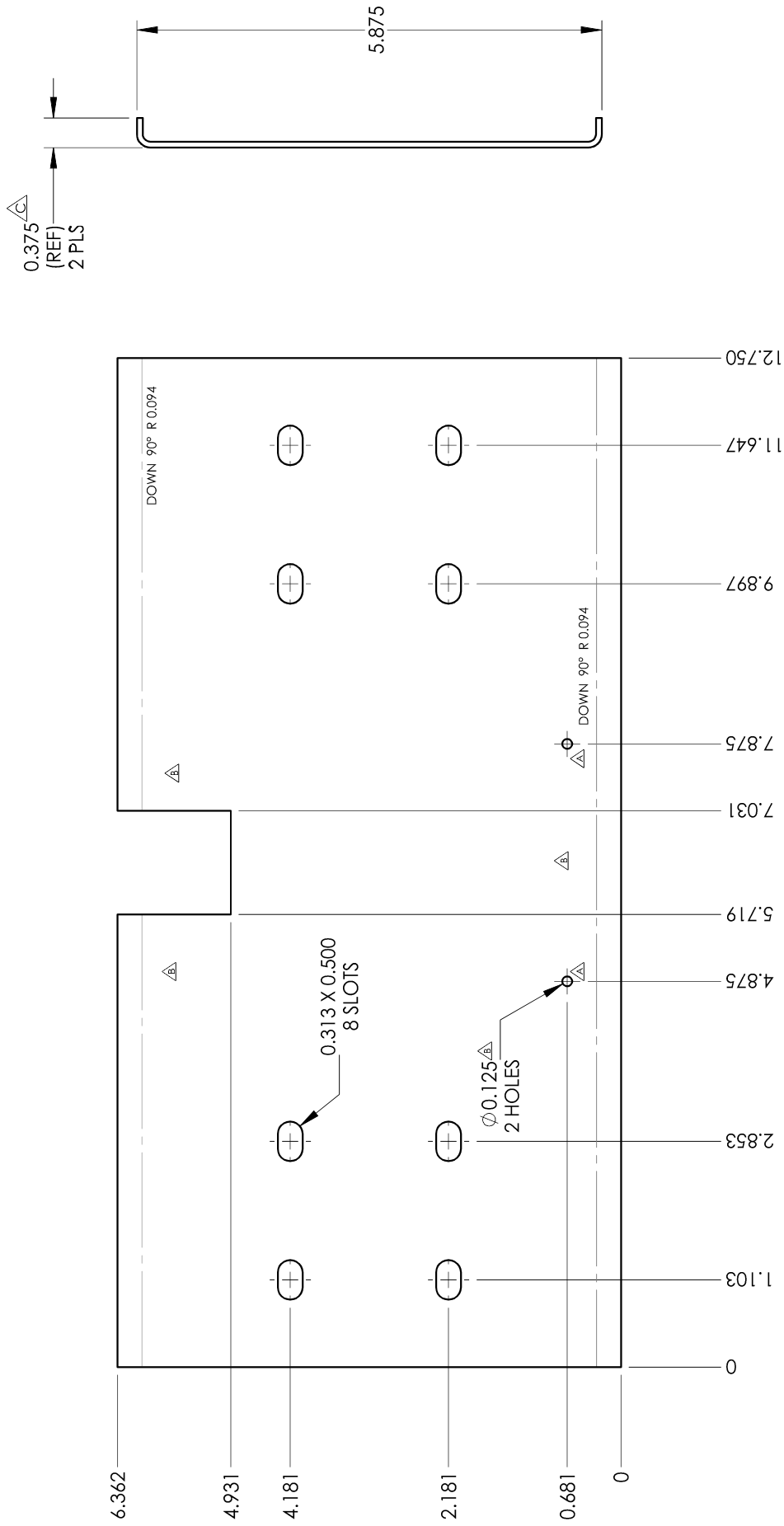

UNLESS OTHERWISE NOTED OR DEPICTED: ALL DIMENSIONS ARE IN INCHES UNLESS OTHERWISE SPECIFIED. ALL SURFACES ARE CONSIDERED CLASS 'D'. REFER TO ENG-009 AND ENG-010 FOR SURFACE FINISH CRITERIA. TOLERANCES: FORMED PARTS ±0.031 REFERENCE DIMENSIONS ±0.063 BLANKED PARTS ±0.010 ANGLES ±2	TITLE: <b>BRACKET, CASTING</b>	MODEL:	DRAWING: <b>W080-1249</b>
	MATERIAL: 14 GA HR P&O	THICKNESS: 1.651 LBS	DRAWN BY: <b>A.RIGDEN</b>
FINISH:	REVISION: <b>C</b>	SCALE: 1:2	SHEET 1 OF 1
(AGR) ADD MTL/MODIFY MTL	DATE: <b>5/21/2013</b>	CHECKED BY:	DATE: <b>6/13/2012</b>

The drawing is the property of Wolf Steel LTD. or NAC. It is to be used only for the project and order number for which it was prepared. All rights are reserved.

**WOLF STEEL™**  
**NAC**  
 Precision Steel Products  
 22.20.13 AR

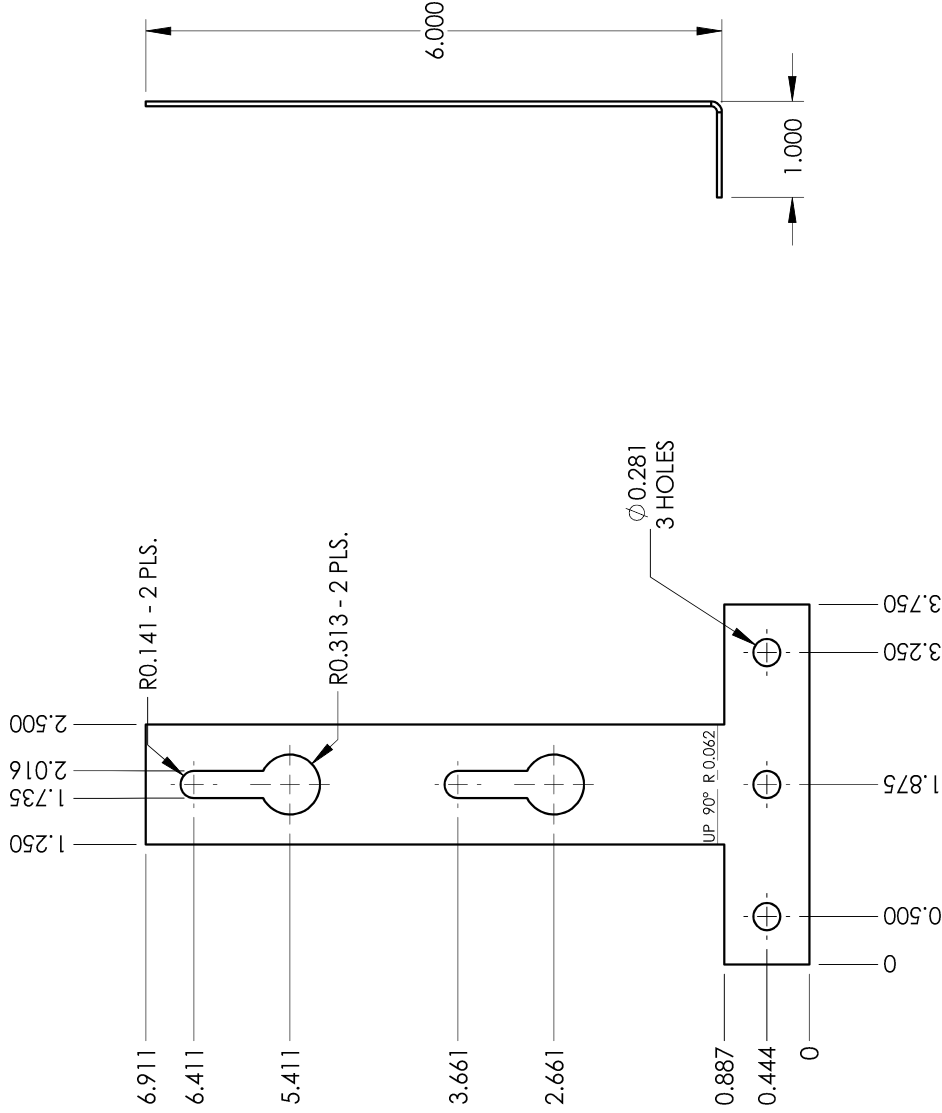

UNLESS OTHERWISE NOTED OR DEPICTED  
 ALL DIMENSIONS ARE OUTSIDE IN INCHES  
 UNLESS OTHERWISE SPECIFIED  
 WHERE APPLICABLE FLAT IS SHOWN FINISHED SIDE UP

TOLERANCES:  
 FORMED PARTS ±0.031"  
 BEAVED PARTS ±0.063"  
 SURFACE DIMENSIONS ±0.063"  
 ANGLES ±2°

  
**WOLF STEEL**
  
**NAC**
  
 NORTH AMERICAN  
 CORRUGATED STEEL

TITLE:	BRACKET, PALLET	MODEL:	W080-1265
MATERIAL:	18 GA GALVANNEAL	THICKNESS:	0.051
FINISH:		SCALE:	1:2
REVISION:	-	SHEET 1 OF 1	JTA
		CHECKED BY:	R.TJART
		DRAWING:	EPI3
		DRAWN BY:	0.051
		DATE:	6/13/2012

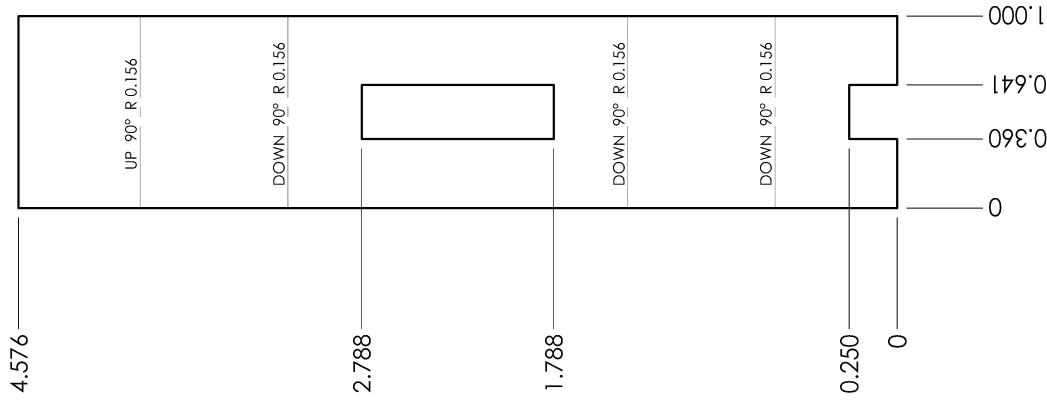
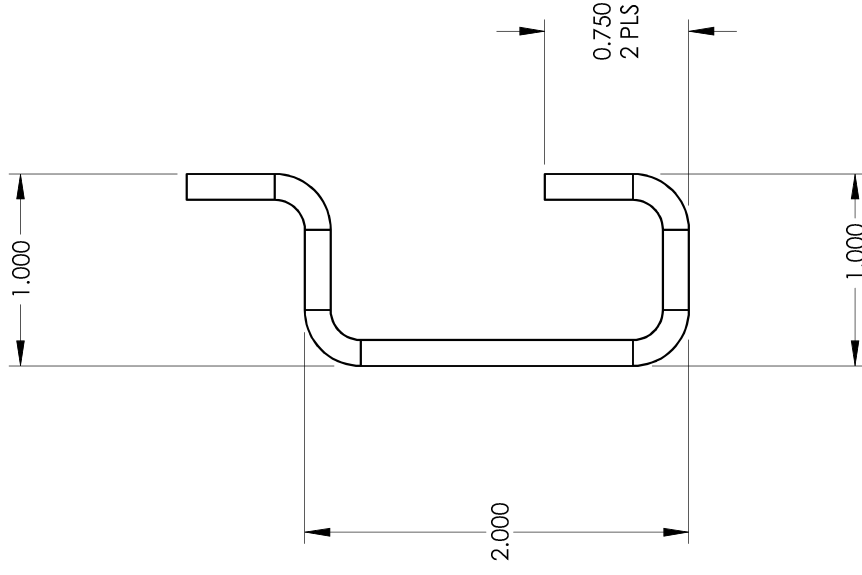

UNLESS OTHERWISE NOTED OR DEPICTED  
 ALL DIMENSIONS ARE OUTSIDE IN INCHES  
 UNLESS OTHERWISE NOTED OTHERWISE  
 WHERE APPLICABLE FLAT IS SHOWN FINISHED SIDE UP

TOLERANCES:  
 FORMED PARTS ±0.031"  
 BEVELLED PARTS ±0.063"  
 SURFACE DIMENSIONS ±.2°  
 ANGLES

**WOLF STEEL**<sup>TM</sup>  
**NAC**  
 NAC Steel  
 A-201 L.P.C.S.  
 C-20110-2011-11

TITLE:	<b>BRACKET, LOG RETAINER</b>	MODEL:	EP13	DRAWING:	<b>W080-1284</b>
MATERIAL:	10 GA HR P&O	THICKNESS:	0.135	DRAWN BY:	<b>A.RIGDEN</b>
FINISH:		SCALE:	1:1	SHEET 1 OF 1	<b>6/13/2012</b>
REVISION:	~	CHECKED BY:			R.TJART



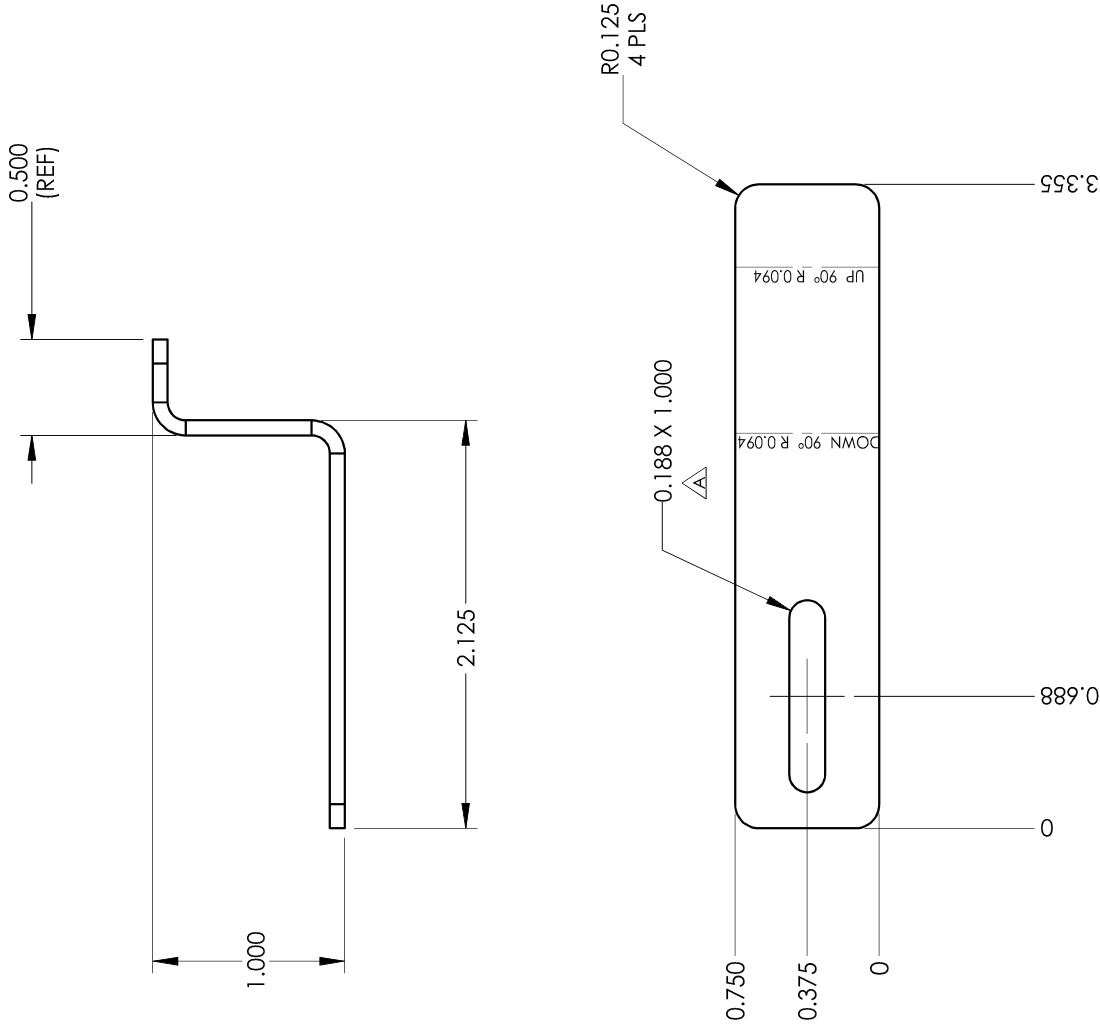

UNLESS OTHERWISE NOTED OR DEPICTED  
ALL DIMENSIONS ARE OUTSIDE IN INCHES  
SURFACES ARE CONSIDERED FINISHED UNLESS  
OTHERWISE SPECIFIED  
WHERE APPLICABLE REFER TO ENG-009 AND ENG-010  
FOR SURFACE FINISH CRITERIA

TOLERANCES:  
FORMED PARTS ±0.031" REFERENCE DIMENSIONS ±0.063"  
BLANKED PARTS ±0.010" ANGLES ±2

10/09/12 AR

**WOLF STEEL**<sup>TM</sup>  
**NAC**  
NORTH AMERICAN  
CORPORATION

TITLE:	BRACKET, FAN SWITCH	MODEL:	EPI3	DRAWING:	W080-1306
MATERIAL:	14 GA HR P&O	THICKNESS:	0.078	DRAWN BY:	A.RIGDEN
FINISH:		SCALE:	1:1	SHEET 1 OF 1	MM/DD/YYYY: 2/1/2013
REVISION:	A	3/20/2014	(SDE) INCREASED SLOT	CHECKED BY:	

D

C

B

A

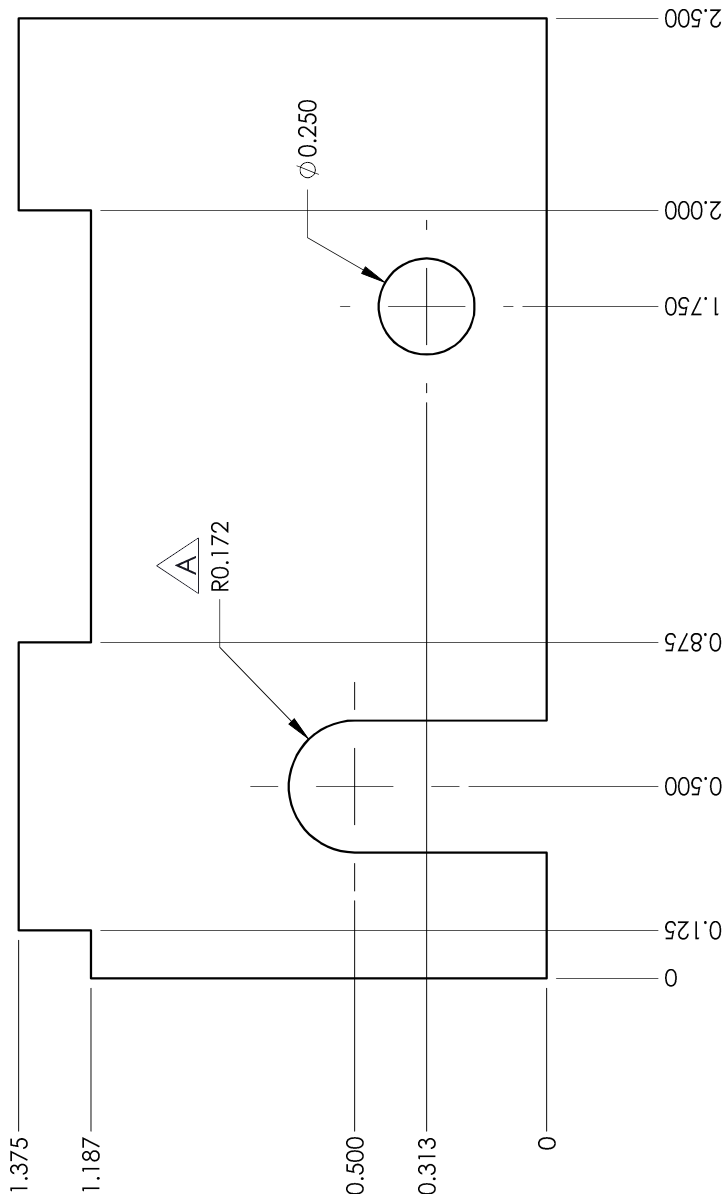

UNLESS OTHERWISE NOTED OR DEPICTED ALL DIMENSIONS ARE OUTSIDE IN INCHES ALL SURFACES ARE CONSIDERED CLASS "D" REFER TO ENG-009 AND ENG-010 FOR SURFACE FINISH CRITERIA	TITLE: <b>BRACKET, CASTING MOUNT (LOWER)</b>		MODEL:	EPI3 DRAWING: <b>W080-1307</b>	
	MATERIAL: 3/16 HR P&O	FINISH:	0.155 LBS	THICKNESS: 0.188	DRAWN BY: <b>HUSAISH</b>
TOLERANCES: FORMED PARTS ±0.031 REFERENCE DIMENSIONS ±0.063 BLANKED PARTS ±0.010 ANGLES ±2°	REVISION: <b>A</b>	REV DATE: <b>9/14/2017</b>	INCREASED SLOT DIAMETER	SCALE: 2:1	SHEET 1 OF 1
1	2	3	4	5	CHECKED BY: <b>CL</b>

This drawing is the property of Wolf Steel LTD. or NAC  
 and is not to be reproduced, copied, or  
 transmitted in any form or by any means  
 without our consent. All rights are reserved.

**WOLF STEEL LTD.**  
 NAC  
 10000 111  
 4500 2100  
 4500 2100

MADE FROM HYDRAULIC SETTING, CLAY BASE  
 CASTABLE FORMULATED WITH A MEDIUM GRIND  
 HIGH TEMP. CALCINED AGGREGATE.  
 APPROX DENSITY 130# PER CU. FT

NOTE: ALL DRAFTS 5° EXCEPT WERE NOTED

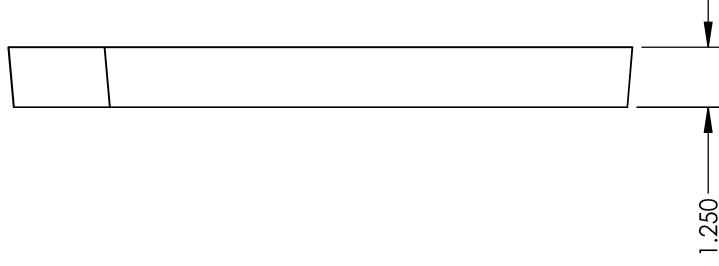
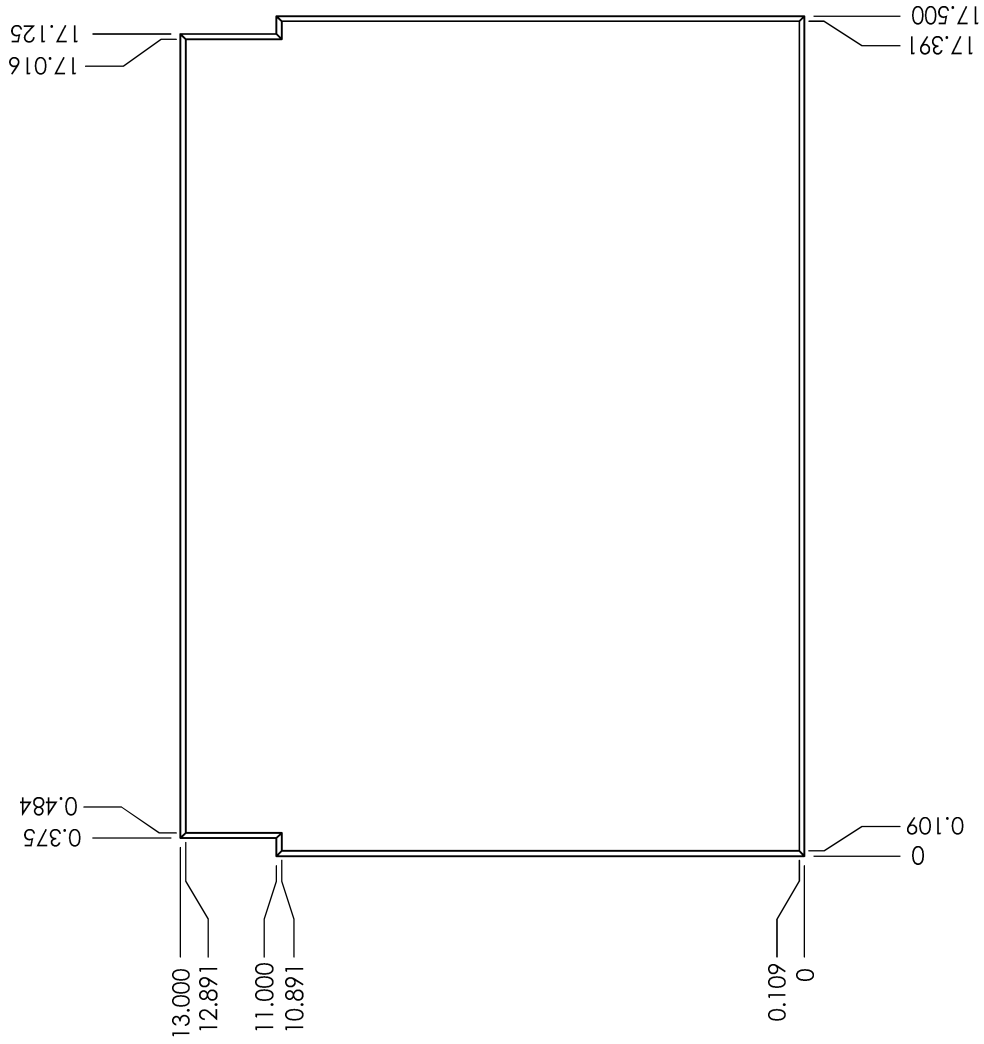
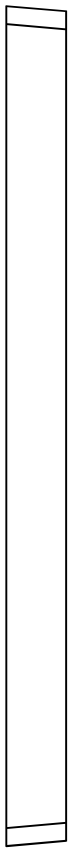

UNLESS OTHERWISE NOTED OR DEPICTED ALL DIMENSIONS ARE OUTSIDE IN INCHES TOLERANCES: DIMENSIONS ±0.125" ANGLES ±1°	TITLE: <b>BRICK, REAR</b>	MODEL:	EPT3	DRAWING:	W090-0190
	MATERIAL: REFRACTORY	20.876 LBS	DRAWN BY:	A.RIGDEN	4/30/2012
FINISH:	SCALE: 1:4	SHEET 1 OF 1	CHECKED BY:	R.TJART	REVISION: ~



MADE FROM HYDRAULIC SETTING, CLAY BASE  
 CASTABLE FORMULATED WITH A MEDIUM GRIND  
 HIGH TEMP. CALCINED AGGREGATE.  
 APPROX DENSITY 130# PER CU. FT

NOTE: ALL DRAFTS 5° EXCEPT WHERE NOTED

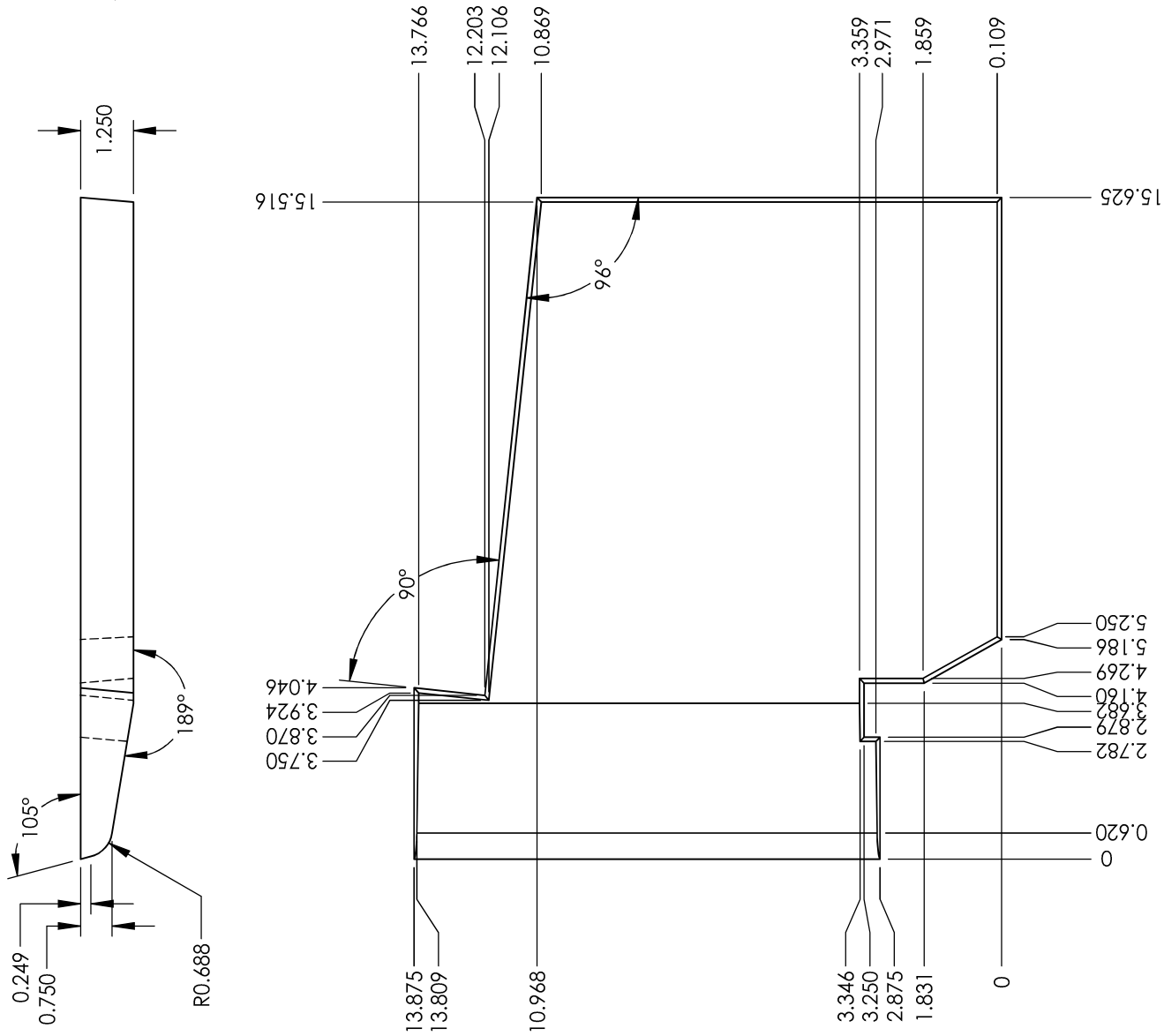

<p>UNLESS OTHERWISE NOTED OR DEPICTED                  ALL DIMENSIONS ARE OUTSIDE IN INCHES</p>		<p>TITLE: <b>BRICK, LEFT SIDE</b></p>	<p>MODEL: EP13</p>	<p>DRAWING: <b>W090-0191</b></p>
<p>TOLERANCES:                  DIMENSIONS ±0.125"                  ANGLES ±1°</p>		<p>MATERIAL: REFRACTORY</p>	<p>15.348 LBS</p>	<p>DRAWN BY: <b>A.RIGDEN</b></p>
<p>FINISH:</p>		<p>REVISION: ~</p>	<p>SCALE: 1:4</p>	<p>MM/DD/YYYY: <b>4/30/2012</b></p>
<p>Checked by: _____</p>		<p>Drawn by: _____</p>	<p>SHEET 1 OF 1</p>	<p>CHECKED BY: <b>R.TJART</b></p>



MADE FROM HYDRAULIC SETTING, CLAY BASE  
 CASTABLE FORMULATED WITH A MEDIUM GRIND  
 HIGH TEMP. CALCINED AGGREGATE.  
 APPROX DENSITY 130# PER CU. FT

NOTE: ALL DRAFTS 5° EXCEPT WHERE NOTED

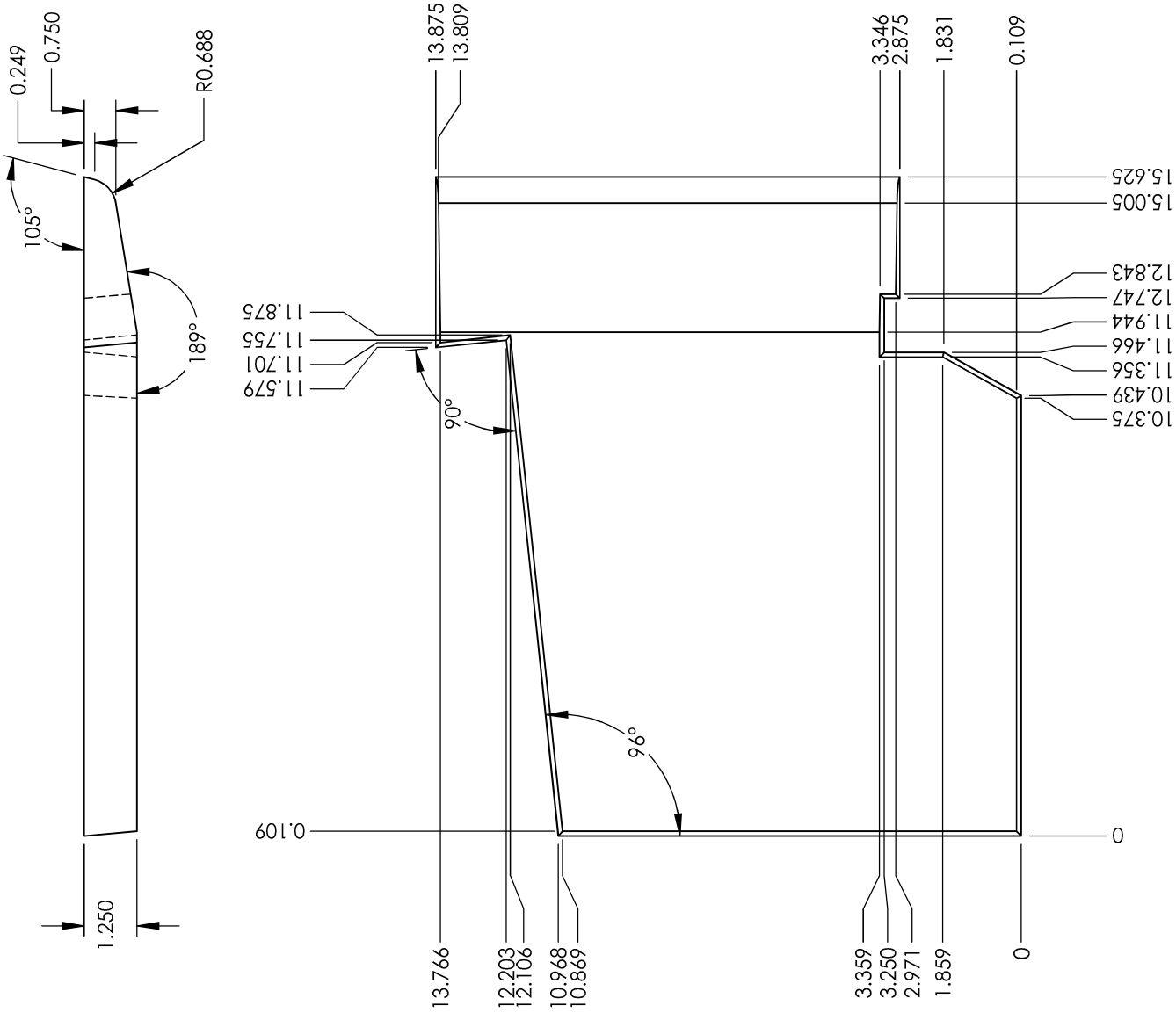

UNLESS OTHERWISE NOTED OR DEPICTED ALL DIMENSIONS ARE OUTSIDE IN INCHES TOLERANCES: DIMENSIONS ±0.125" ANGLES ±1°	TITLE: <b>BRICK, RIGHT SIDE</b>	MODEL: EP13	DRAWING: <b>W090-0192</b>
	MATERIAL: REFRACTORY	WEIGHT: 15.348 LBS	DRAWN BY: <b>A.RIGDEN</b>
FINISH:	SCALE: 1:4	SHEET 1 OF 1	DATE: <b>4/30/2012</b>
REVISION: 2	CHECKED BY:	R.TJART	DRAWING:



MADE FROM HYDRAULIC SETTING, CLAY BASE  
 CASTABLE FORMULATED WITH A MEDIUM GRIND  
 HIGH TEMP. CALCINED AGGREGATE.  
 APPROX DENSITY 130# PER CU. FT

NOTE: ALL DRAFTS 5° EXCEPT WERE NOTED

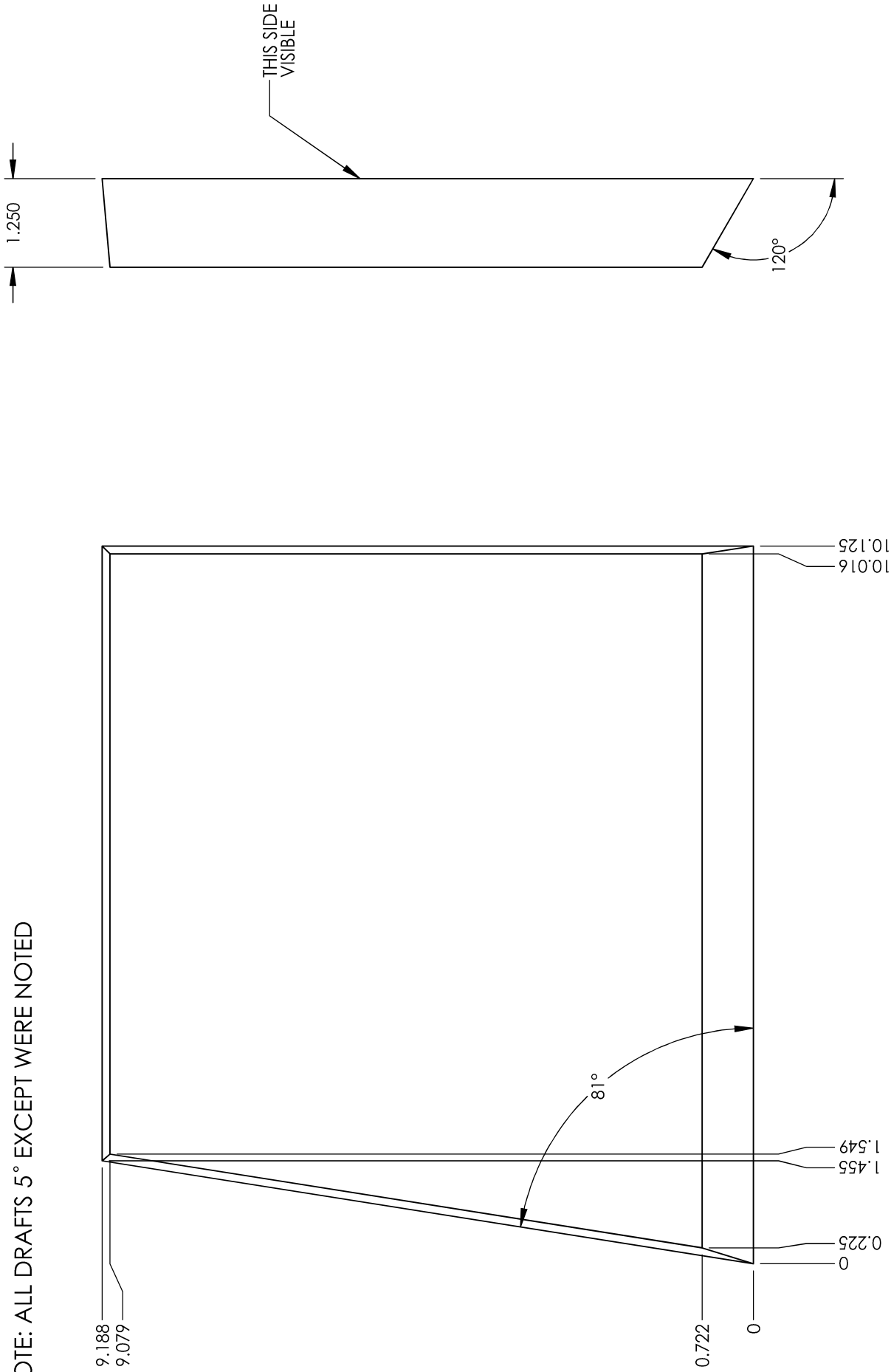

<p>UNLESS OTHERWISE NOTED OR DEPICTED                  ALL DIMENSIONS ARE OUTSIDE IN INCHES</p>		<p>TITLE: <b>BRICK, BOTTOM (RS)</b></p>	<p>MODEL: EP13</p>	<p>DRAWING: <b>W090-0193</b></p>
<p>TOLERANCES:                  DIMENSIONS ±0.125"                  ANGLES ±1°</p>		<p>MATERIAL: REFRACTORY</p>	<p>7.620 LBS</p>	<p>DRAWN BY: <b>A.RIGDEN</b></p>
<p>FINISH:</p>		<p>SCALE: 1:2</p>	<p>SHEET 1 OF 1</p>	<p>MM/DD/YYYY: <b>4/30/2012</b></p>
<p>REVISION: ~</p>		<p>CHECKED BY: <b>R.TJART</b></p>		

The drawing is the property of Wolf Steel Ltd. or NAC. It is to be used only for the project and for the order for which it was prepared. All rights are reserved.

**WOLF STEEL**<sup>TM</sup>  
 REFRACTORY  
 NAC  
 NORTH AMERICAN  
 CEMENTATION

MADE FROM HYDRAULIC SETTING, CLAY BASE  
 CASTABLE FORMULATED WITH A MEDIUM GRIND  
 HIGH TEMP. CALCINED AGGREGATE.  
 APPROX DENSITY 130# PER CU. FT

NOTE: ALL DRAFTS 5° EXCEPT WHERE NOTED

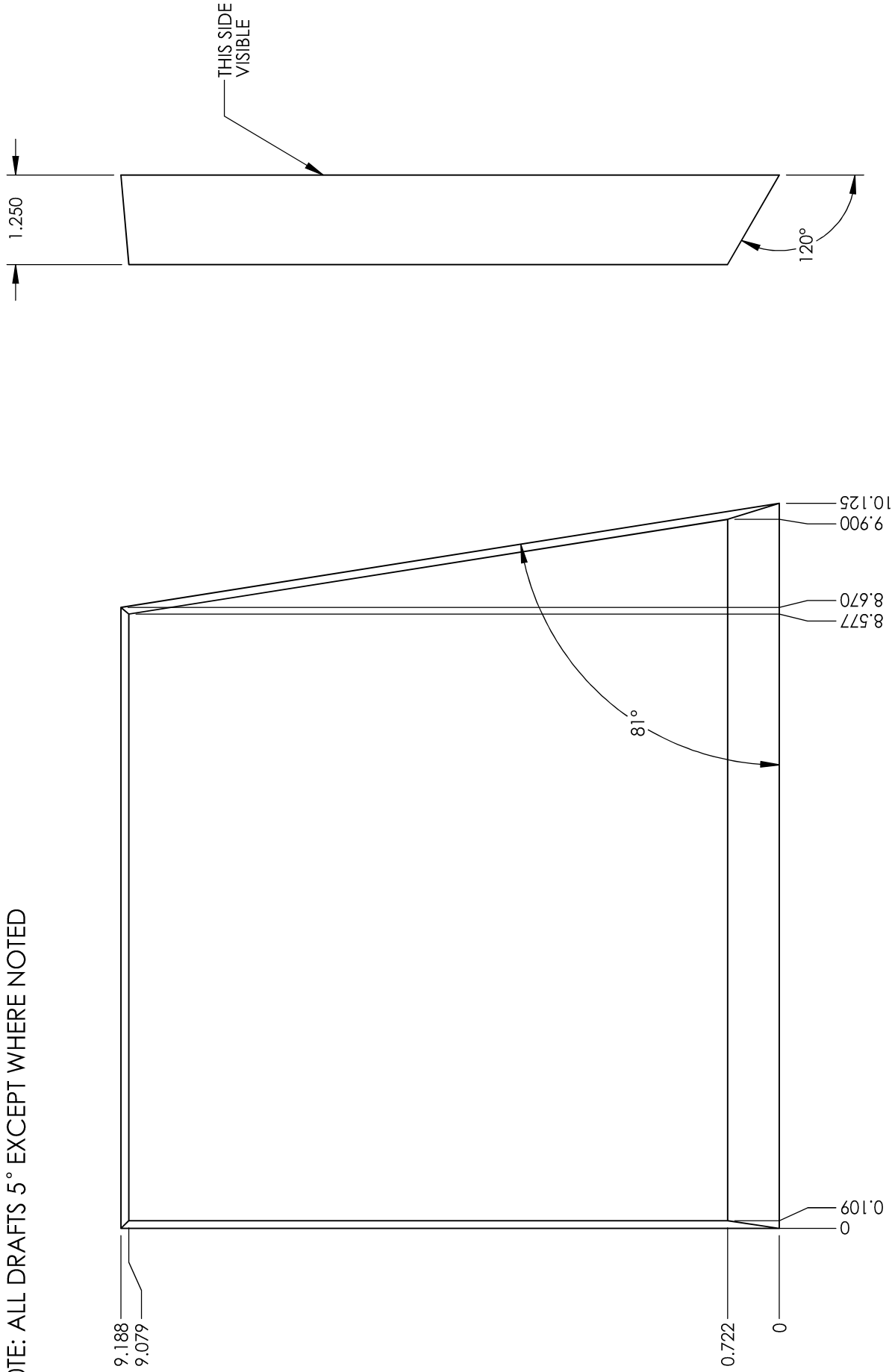



UNLESS OTHERWISE NOTED OR DEPICTED ALL DIMENSIONS ARE OUTSIDE IN INCHES TOLERANCES: DIMENSIONS ±0.125" ANGLES ±1°	TITLE: <b>BRICK, BOTTOM (LS)</b>	MODEL: EP13	DRAWING: <b>W090-0194</b>
	MATERIAL: REFRACTORY	7.620 LBS	DRAWN BY: <b>A.RIGDEN</b>
FINISH:	SCALE: 1:2	SHEET 1 OF 1	MM/DD/YYYY: <b>4/30/2012</b>
REVISION: ~	CHECKED BY:	R.TJART	R.TJART

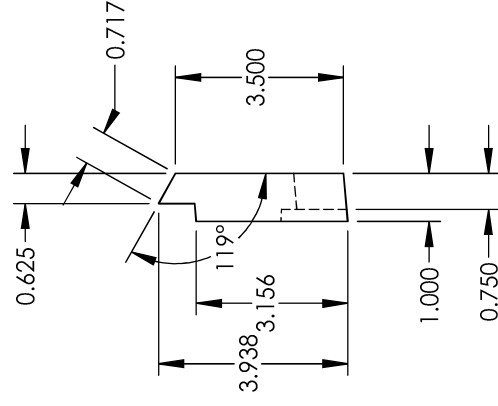
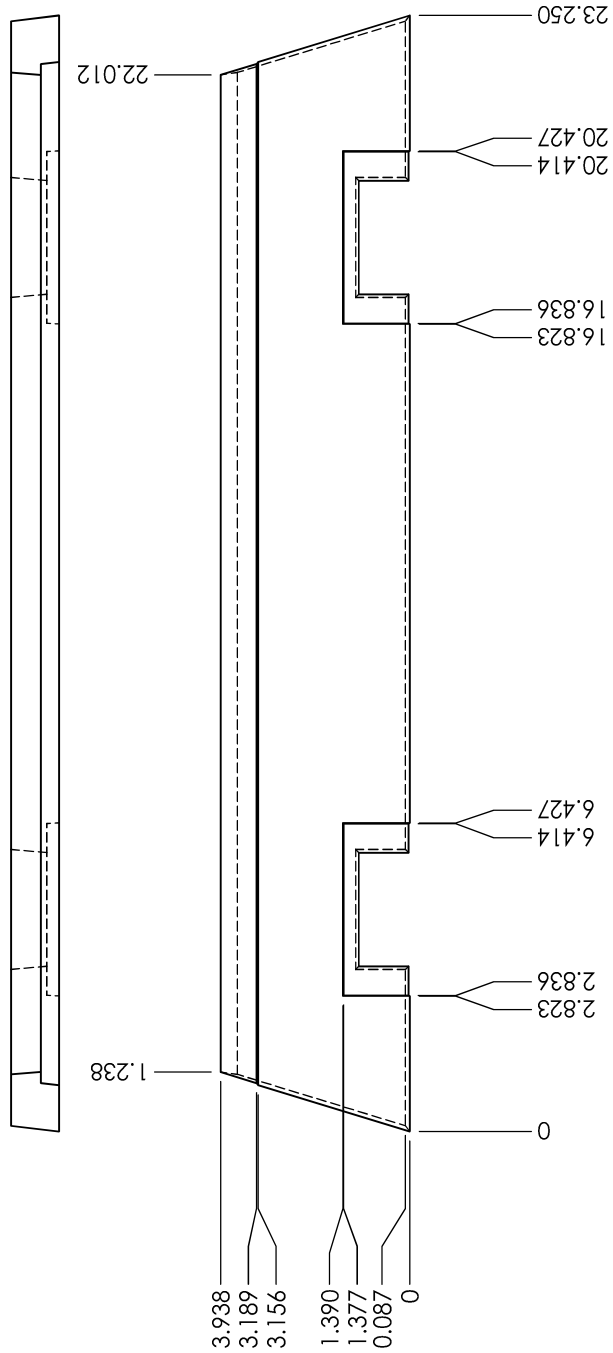
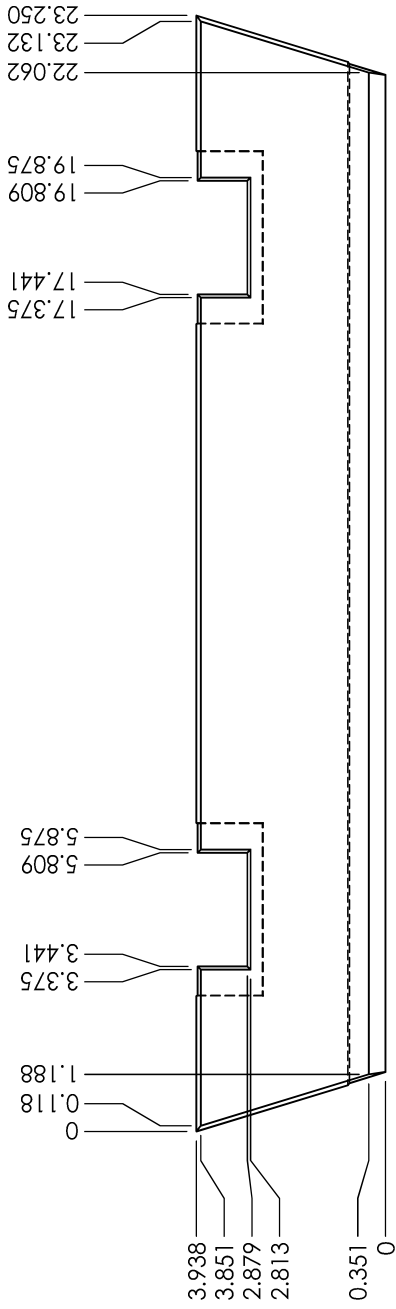

MADE FROM HYDRAULIC SETTING, CLAY BASE  
 CASTABLE FORMULATED WITH A MEDIUM GRIND  
 HIGH TEMP. CALCINED AGGREGATE.  
 APPROX DENSITY 130# PER CU. FT

NOTE: ALL DRAFTS 5° EXCEPT WHERE NOTED



 <p>WOLF STEEL<sup>TM</sup>                  NAC                  REFRACTORY                  CORP.</p>	UNLESS OTHERWISE NOTED OR DEPICTED ALL DIMENSIONS ARE OUTSIDE IN INCHES TOLERANCES: DIMENSIONS ±0.125" ANGLES ±1°	TITLE: <b>BRICK, FRONT LEDGE</b> MATERIAL: REFRACTORY FINISH: REVISION: <b>A</b> 5/31/2012 (AGR) REDESIGN PART	MODEL: EP13 MODEL: 5.316 LBS SCALE: 1:4 SHEET 1 OF 1	DRAWING: <b>W090-0195</b> DRAWN BY: <b>A.RIGDEN</b> MM/DD/YYYY: <b>4/30/2012</b> CHECKED BY: <b>R.TJART</b>
--	---	---	---	--



MADE FROM HYDRAULIC SETTING, CLAY BASE  
 CASTABLE FORMULATED WITH A MEDIUM GRIND  
 HIGH TEMP. CALCINED AGGREGATE.  
 APPROX DENSITY 130# PER CU. FT

NOTE: ALL DRAFTS 5° EXCEPT WHERE NOTED

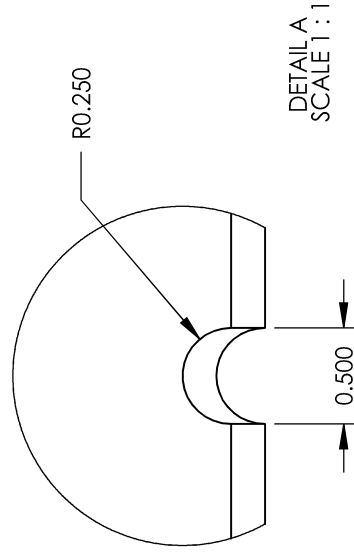
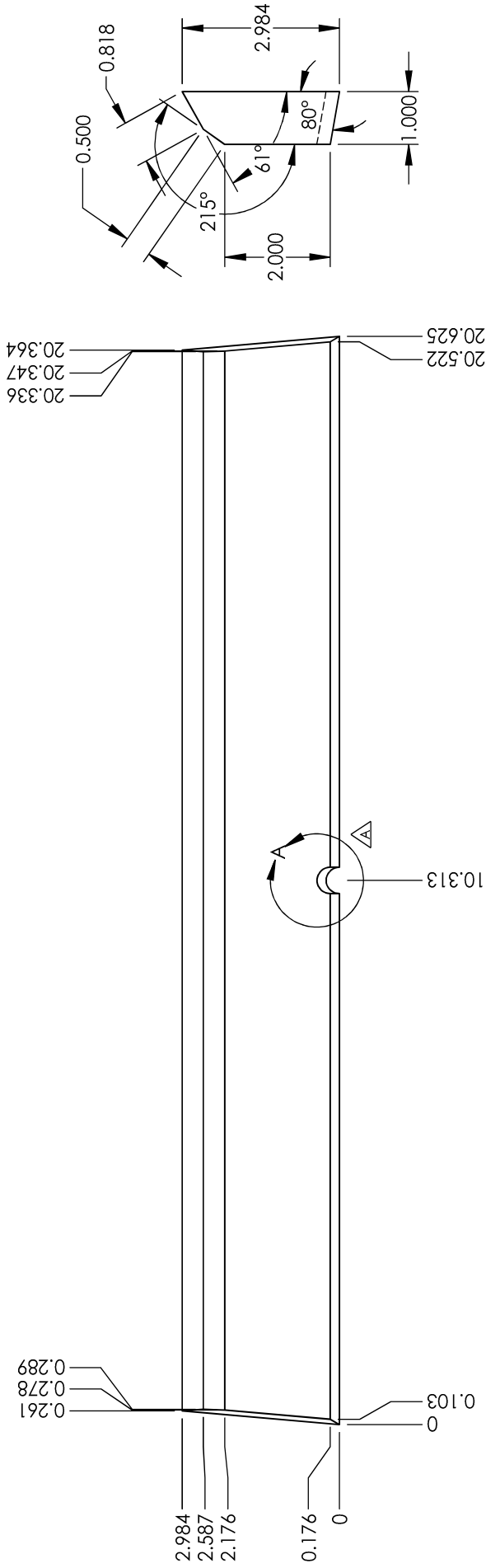

UNLESS OTHERWISE NOTED OR DEPICTED ALL DIMENSIONS ARE OUTSIDE IN INCHES TOLERANCES: DIMENSIONS ±0.125" ANGLES ±1°	TITLE: <b>BRICK, FRONT</b>	MODEL: EP13	DRAWING: <b>W090-0196</b>
	MATERIAL: REFRACTORY	3.924 LBS	DRAWN BY: <b>A.RIGDEN</b>
FINISH:	SCALE: 1:3	SHEET 1 OF 1	MM/DD/YYYY: <b>4/30/2012</b>
REVISION: <b>A</b>	<b>5/27/2013</b>	(AGR) ADD RELIEF	CHECKED BY: <b>R.TJART</b>



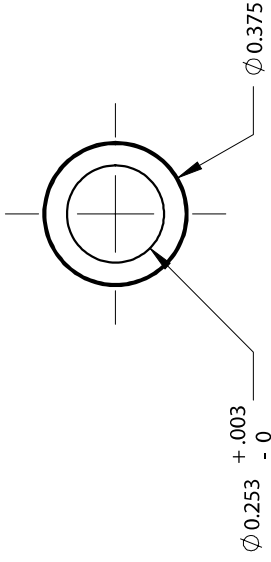
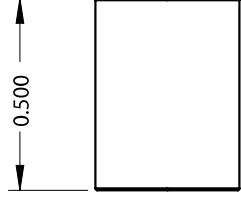
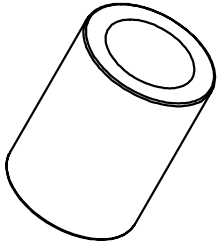

**Reference Only**

NOTE: Made of hardened steel

WOLF STEEL

DIMS: INCHES/MM

TITLE: BUSHING, ID 0.253" X OD 0.375"

DWG#: W105-0017

REV:

DATE: 07.09.12\_RICH

5 4 3 2 1

D C B A

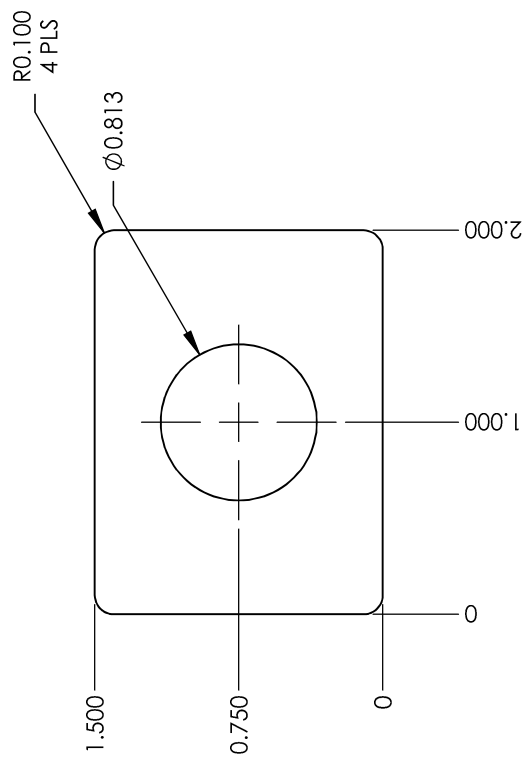

<small>This drawing is the property of Wolf Steel Ltd. or NAC. It is to be used in any manner without our consent. All rights are reserved.</small> <b>WOLF STEEL™</b> <small>© 2019 8192926</small>	<small>UNLESS OTHERWISE NOTED OR DEPICTED ALL DIMENSIONS ARE OUTSIDE IN INCHES ALL SURFACES ARE CONSIDERED CLASS "D" REFER TO ENG-009 FOR SURFACE FINISH CRITERIA</small> <b>TOLERANCES:</b> FORMED PARTS ±0.031 REFERENCE DIMENSIONS ±0.063 BURNED PARTS ±0.010 ANGLES ±2°	TITLE: <b>CAP, S/A ENTRANCE</b> MATERIAL: 14 GA HR P&O FINISH:	MODEL: EPI3-1 THICKNESS: 0.052 LBS SCALE: 1:4	DRAWING: <b>W120-0100</b> ISSUE DATE: <b>UNRELEASED</b> DRAWN BY: <b>UNRELEASED</b> CHECKED BY: <b>UNRELEASED</b>
	PROJECT LEAD: P HODGES REV NOTE:	SHEET 1 OF 1	0.052 LBS CN#:	5

1 2 3 4 5



- NOTES:  
 1) ALL DRAFT ANGLES 5° UNLESS OTHERWISE STATED  
 2) DRAWING DOES NOT CONTAIN SUFFICIENT DETAILS TO DEVELOP TOOLING  
 3) WOLF STEEL APPROVED CAD MODEL IS REQUIRED  
 4) CLASS A SURFACES  
 5) CLASS A SURFACE FINISH BETWEEN Rg 6.3 - 12.5 (RMS 275 - 500)  
 6) DENOTES CRITICAL INSPECTION CRITERIA  
 7) TOLERANCE SHOWN WITHIN REFERENCED DIMENSION BUBBLE IS ONLY  
 8) APPLICABLE TO PORCELAIN ENAMELED PARTS  
 9) USE TOLERANCE TABLE PROVIDED FOR DRAWING DIMENSIONS (DO NOT USE TOLERANCES IN TITLE BLOCK)

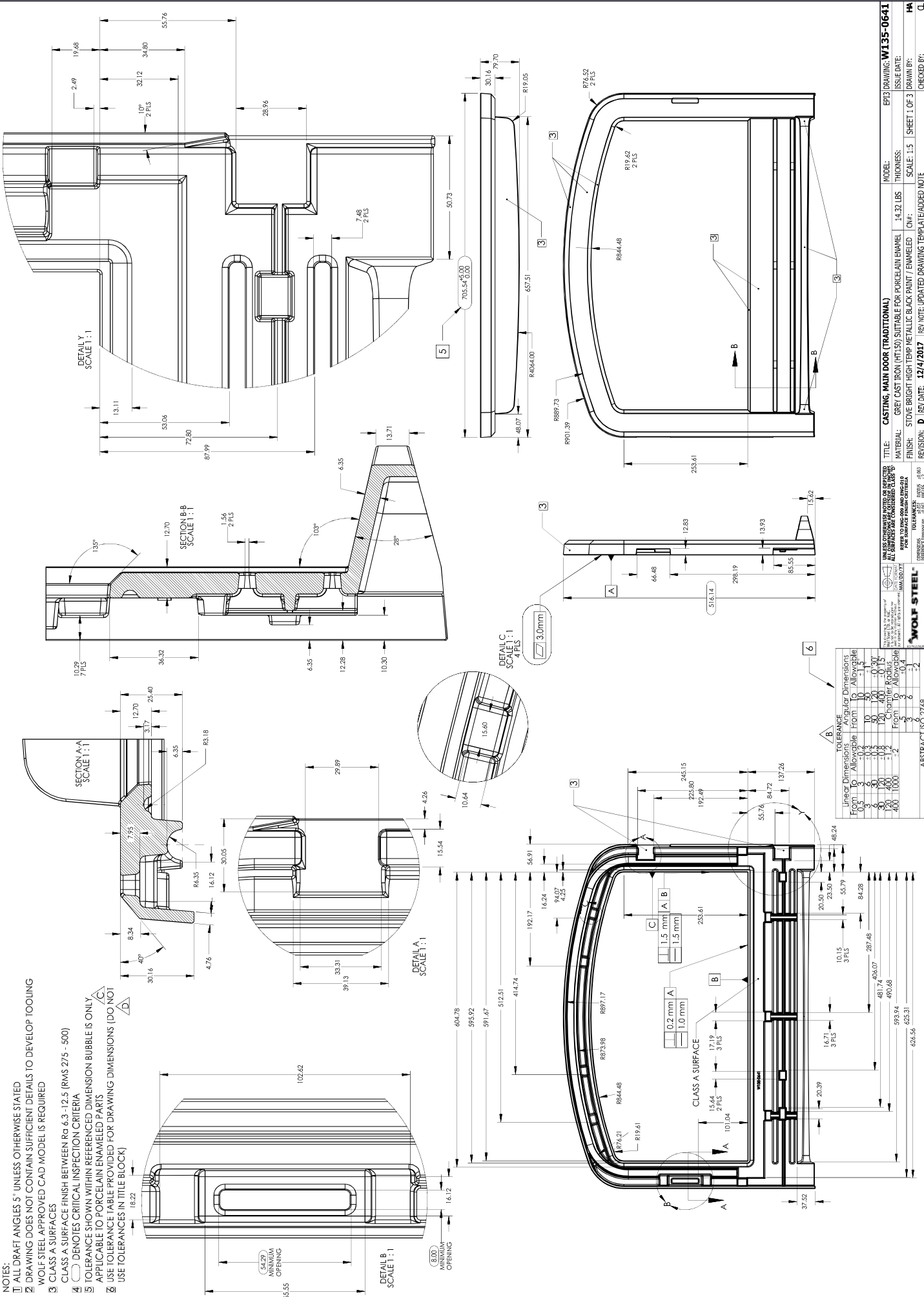

TOLERANCE		ANGULAR DIMENSIONS	
FROM	TO	FROM	TO
0.5	3	10	15
3	10	15	30
10	30	30	45
30	100	45	90
100	400	90	180
400	1000	180	360
		360	450
		450	900
		900	1800
		1800	3600
		3600	7200
		7200	14400
		14400	28800
		28800	57600
		57600	115200
		115200	230400
		230400	460800
		460800	921600
		921600	1843200
		1843200	3686400
		3686400	7372800
		7372800	14745600
		14745600	29491200
		29491200	58982400
		58982400	117964800
		117964800	235929600
		235929600	471859200
		471859200	943718400
		943718400	1887436800
		1887436800	3774873600
		3774873600	7549747200
		7549747200	15099494400
		15099494400	30198988800
		30198988800	60397977600
		60397977600	120795955200
		120795955200	241591910400
		241591910400	483183820800
		483183820800	966367641600
		966367641600	1932735283200
		1932735283200	3865470566400
		3865470566400	7730941132800
		7730941132800	15461882265600
		15461882265600	30923764531200
		30923764531200	61847529062400
		61847529062400	123695058124800
		123695058124800	247390116249600
		247390116249600	494780232499200
		494780232499200	989560464998400
		989560464998400	1979120929996800
		1979120929996800	3958241859993600
		3958241859993600	7916483719987200
		7916483719987200	15832967439974400
		15832967439974400	31665934879948800
		31665934879948800	63331869759897600
		63331869759897600	126663739519795200
		126663739519795200	253327479039590400
		253327479039590400	506654958079180800
		506654958079180800	1013309916158361600
		1013309916158361600	2026619832316723200
		2026619832316723200	4053239664633446400
		4053239664633446400	8106479329266892800
		8106479329266892800	16212958658533785600
		16212958658533785600	32425917317067571200
		32425917317067571200	64851834634135142400
		64851834634135142400	129703669268270284800
		129703669268270284800	259407338536540569600
		259407338536540569600	518814677073081139200
		518814677073081139200	1037629354146162278400
		1037629354146162278400	2075258708292324556800
		2075258708292324556800	4150517416584649113600
		4150517416584649113600	8301034833169298227200
		8301034833169298227200	16602069666338596454400
		16602069666338596454400	33204139332677192908800
		33204139332677192908800	66408278665354385817600
		66408278665354385817600	132816557330708771635200
		132816557330708771635200	265633114661417543270400
		265633114661417543270400	531266229322835086540800
		531266229322835086540800	1062532458645670173081600
		1062532458645670173081600	2125064917291340346163200
		2125064917291340346163200	4250129834582680692326400
		4250129834582680692326400	8500259669165361384652800
		8500259669165361384652800	17000519338330722737305600
		17000519338330722737305600	34001038676661445474611200
		34001038676661445474611200	68002077353322890949222400
		68002077353322890949222400	13600414670664578198844800
		13600414670664578198844800	27200829341329155997789600
		27200829341329155997789600	5440165868265831199555782400
		5440165868265831199555782400	10880331736531663991115548800
		10880331736531663991115548800	21760663473063327982231097600
		21760663473063327982231097600	43521326946126655964462153600
		43521326946126655964462153600	87042653892253311928932307200
		87042653892253311928932307200	17408530778450663857864614400
		17408530778450663857864614400	34817061556901327715729228800
		34817061556901327715729228800	69634123113802655431446457600
		69634123113802655431446457600	13926824622760531086288915200
		13926824622760531086288915200	27853649245521062172577830400
		27853649245521062172577830400	55707298491042124345155660800
		55707298491042124345155660800	111414596982084248690311331200
		111414596982084248690311331200	222829193964168497380626662400
		222829193964168497380626662400	445658387928336994761253324800
		445658387928336994761253324800	891316775856673989522506649600
		891316775856673989522506649600	1782633551713347979045133299200
		1782633551713347979045133299200	3565267103426695958090266598400
		3565267103426695958090266598400	71305342068533919161805331977600
		71305342068533919161805331977600	142610684137067838323610667955200
		142610684137067838323610667955200	285221368274135676647221359910400
		285221368274135676647221359910400	570442736548271353294442719820800
		570442736548271353294442719820800	1140885473096542706588885439641600
		1140885473096542706588885439641600	2281770946193085413177771079283200
		2281770946193085413177771079283200	4563541892386170826355542158566400
		4563541892386170826355542158566400	9127083784772341652711084317132800
		9127083784772341652711084317132800	1825416756954468330542168863427200
		1825416756954468330542168863427200	3650833513908936661088437726844800
		3650833513908936661088437726844800	73016670278178733221776755353689600
		73016670278178733221776755353689600	146033340556357466435553510670739200
		146033340556357466435553510670739200	29206668111271493287111107341478400
		29206668111271493287111107341478400	58413336222542986574222214682956800
		58413336222542986574222214682956800	116826674451059731148444429369132800
		116826674451059731148444429369132800	233653348902119462296888858738265600
		233653348902119462296888858738265600	467306697804238924593777717476531200
		467306697804238924593777717476531200	934613395608477849187555434953062400
		934613395608477849187555434953062400	186922679121695569837511089906124800
		186922679121695569837511089906124800	373845358243391139675022179981249600
		373845358243391139675022179981249600	74769071648678227935004435996249600
		74769071648678227935004435996249600	14953814329735645787000887199249600
		14953814329735645787000887199249600	2990762865947129157400177439849600
		2990762865947129157400177439849600	5981525731894258314800354879699200
		5981525731894258314800354879699200	1196305146378851622960709759399400
		1196305146378851622960709759399400	2392610292757703245921419518798800
		2392610292757703245921419518798800	4785220585515406491842839037597600
		4785220585515406491842839037597600	9570441171030812983685678075195200
		9570441171030812983685678075195200	1914088234206162596737135650390400
		1914088234206162596737135650390400	3828176468412325193475471301080800
		3828176468412325193475471301080800	7656352936824650386950942602161600
		7656352936824650386950942602161600	15312705873649300773901884404323200
		15312705873649300773901884404323200	30625411747298601547803768808646400
		30625411747298601547803768808646400	61250823494597203095607537617292800
		61250823494597203095607537617292800	122501646989194406191215075234585600
		122501646989194406191215075234585600	245003293978388812382430150469171200
		245003293978388812382430150469171200	490006587956777624764860300938342400
		490006587956777624764860300938342400	98001317591355524952892060187668800
		98001317591355524952892060187668800	196002631182711049055781203755337600
		196002631182711049055781203755337600	3920052623654220981115754475106675200
		3920052623654220981115754475106675200	7840105247308441962231508950213334400
		7840105247308441962231508950213334400	1568021049461688392446301790042668800
		1568021049461688392446301790042668800	3136042098923376784892603580085337600
		3136042098923376784892603580085337600	6272084197846753569785207160170675200
		6272084197846753569785207160170675200	12544168396693507139570414320341350400
		12544168396693507139570414320341350400	25088336793387014279140828640686700800
		25088336793387014279140828640686700800	50176673586774028558281657281373414400
		50176673586774028558281657281373414400	10035334717354805711655631445626828800
		10035334717354805711655631445626828800	20070669434709611423311126888917171200
		20070669434709611423311126888917171200	401413388694192228466222537778344400
		401413388694192228466222537778344400	802826777388384456932445075556688800
		802826777388384456932445075556688800	1605653554776768913864890151113377600
		160565355477676	

- NOTES:
- 1 (C) DENOTES CRITICAL INSPECTION CRITERIA
  - 2 DRAWING DOES NOT CONTAIN SUFFICIENT DETAILS TO DEVELOP TOOLING
  - 3 WOLF STEEL APPROVED CAD MODEL IS REQUIRED
  - 3 USE TOLERANCE TABLE PROVIDED FOR DRAWING DIMENSIONS (DO NOT USE TOLERANCES IN TITLE BLOCK)

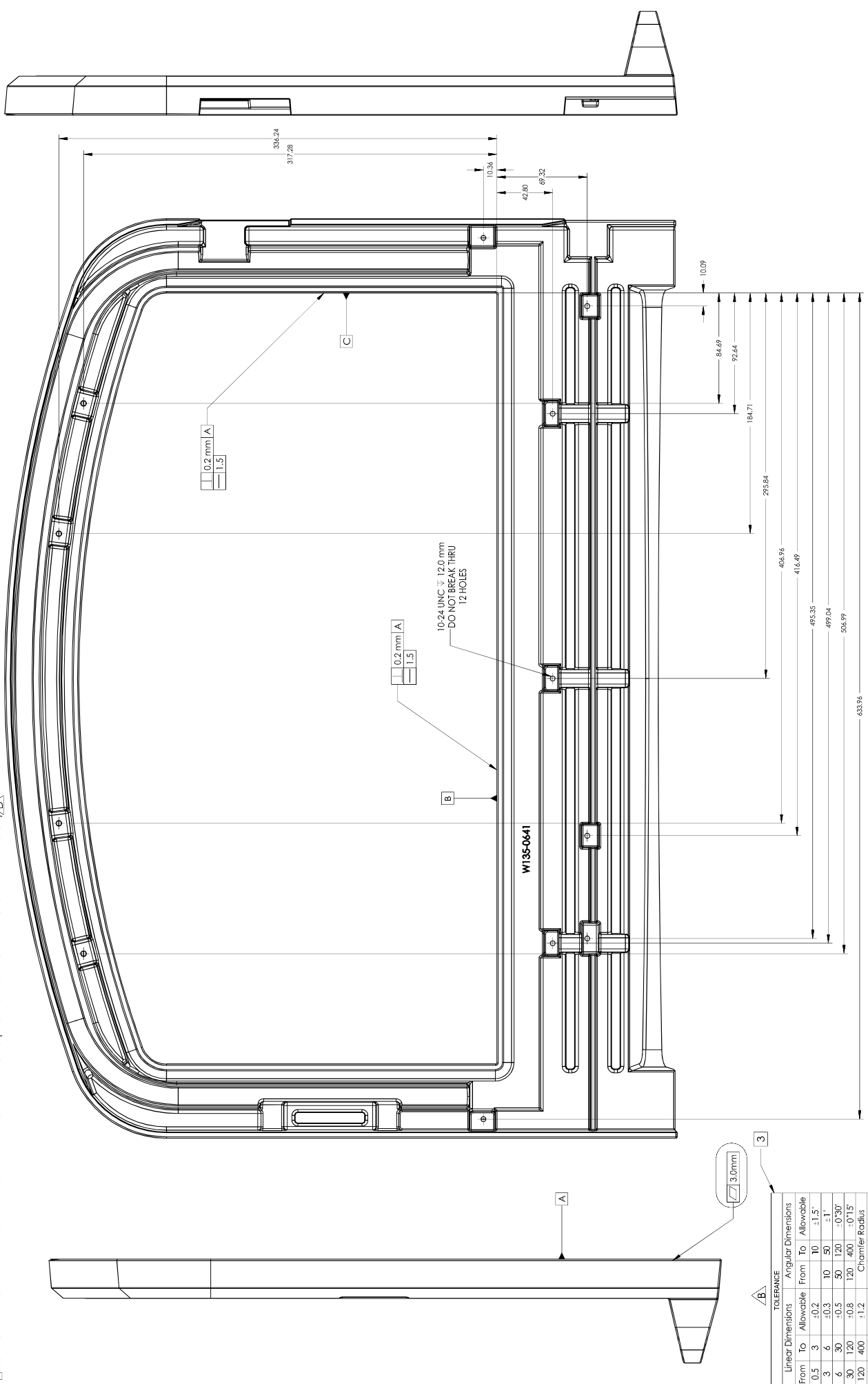

TOLERANCE		Angular Dimensions			
Linear Dimensions	From	To	Allowable		
0.5	3	-0.2	10	±1.5°	
3	6	-0.3	10	±1°	
6	30	-0.5	50	120	-0°30'
30	120	-0.8	120	400	-0°15'
120	400	+1.2	Chamfer Radius		
400	1000	-2	From	To	Allowable
			3	3	-0.4
			6	6	-1
			6	6	-2

UNLESS OTHERWISE NOTED OR SPECIFIED, ALL DIMENSIONS ARE TO BE IN MILLIMETERS AND ANGLES IN DEGREES. WOLF STEEL SHALL BE RESPONSIBLE FOR THE ACCURACY OF THE DIMENSIONS AND ANGLES SHOWN ON THIS DRAWING. WOLF STEEL SHALL BE RESPONSIBLE FOR THE ACCURACY OF THE DIMENSIONS AND ANGLES SHOWN ON THIS DRAWING.

WOLF STEEL  
 10000 WOLF STEEL DRIVE  
 WOLF STEEL, MISSOURI 63073-1000  
 PHONE: 636-337-1000 FAX: 636-337-1001  
 WWW.WOLFSTEEL.COM

MODEL: EPD DRAWING: W135-0641  
 MATERIAL: GREY CAST IRON (HT150) SUITABLE FOR PORCELAIN ENAMEL 14.32 LBS  
 THICKNESS: 1.2  
 FINISH: STOVE BRIGHT HIGH TEMP METALLIC BLACK PAINT / ENAMELED  
 CNF: 1.2  
 SCALE: 1:2  
 SHEET 2 OF 3  
 DRAWN BY: PH  
 REVISION: D REV DATE: 12/4/2017 REV NOTE: UPDATED DRAWING TEMPLATE/ADDED NOTE  
 CHECKED BY: C.







- NOTES:
- 1) DENOTES CRITICAL INSPECTION CRITERIA
  - 2) DRAWING DOES NOT CONTAIN SUFFICIENT DETAILS TO DEVELOP TOOLING
  - 3) WOLF STEEL APPROVED CAD MODEL IS REQUIRED
  - 4) USE TOLERANCE TABLE PROVIDED FOR DRAWING DIMENSIONS (DO NOT USE TOLERANCES IN TITLE BLOCK)

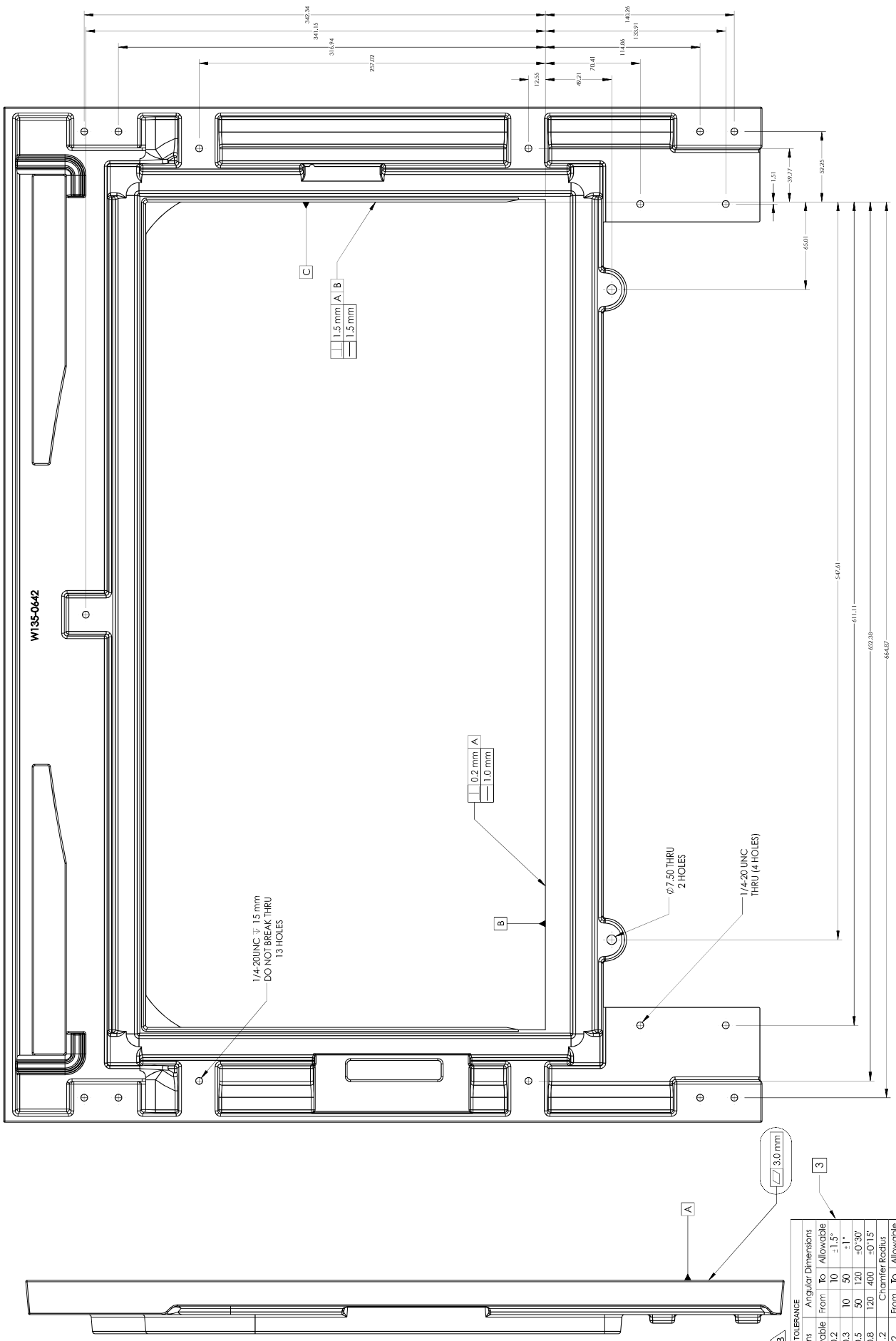

TOLERANCE		Angular Dimensions	
Linear Dimensions	Angular Dimensions	From	To
0.5	3	10	±1.5°
3	6	10	±1°
6	30	50	+0°-30'
30	120	50	+0°-15'
120	400	120	±1.2°
400	1000	120	±2°
		Chamfer Radius	
		From	To
		3	±0.4
		6	±1
		12	±2

UNLESS OTHERWISE NOTED OR SPECIFIED, ALL DIMENSIONS AND TOLERANCES ARE TO BE PERFORMED TO THE DIMENSIONS AND TOLERANCES SPECIFIED IN THE DRAWING. WOLF STEEL IS NOT RESPONSIBLE FOR ANY ERRORS OR OMISSIONS IN THIS DRAWING. WOLF STEEL APPROVES THIS DRAWING FOR THE PURPOSES OF MANUFACTURE.

**WOLF STEEL**  
 10000 100th Ave S, Suite 100, Burnsville, MN 55337  
 612-891-1111  
 www.wolfsteel.com

**CASTING, FRONT (TRADITIONAL)**  
 MODEL: W135-0642  
 MATERIAL: GREY CAST IRON (HT150) SUITABLE FOR PORCELAIN ENAMEL 15.30 LBS  
 FINISH: STOVE BRIGHT HIGH TEMP METALLIC BLACK PAINT/ENAMELED  
 THICKNESS: 1.2  
 SCALE: 1:2  
 SHEET 2 OF 3  
 DRAWN BY: HA  
 REVISION: F REV DATE: 12/4/2017 REV NOTE: UPDATED DRAWING TEMPLATE / ADDED NOTE  
 CHECKED BY: CL

ISSUE DATE: 12/4/2017

- NOTES:
- 1 DENOTES CRITICAL INSPECTION CRITERIA
  - 2 HATCHED AREA TO BE MASKED PRIOR TO ENAMELLING
  - 3 HINGE BLOCK MUST SIT FLAT TO SURFACE ALONG HORIZONTAL TRAVEL
  - 4 DRAWING DOES NOT CONTAIN SUFFICIENT DETAILS TO DEVELOP TOOLING
  - WOLF STEEL APPROVED CAD MODEL IS REQUIRED
  - 5 USE TOLERANCE TABLE PROVIDED FOR DRAWING DIMENSIONS (DO NOT USE TOLERANCES IN TITLE BLOCK)

DETAIL Y  
TOP AND BOTTOM  
HINGE HOLES ARE NOT  
ALIGNED

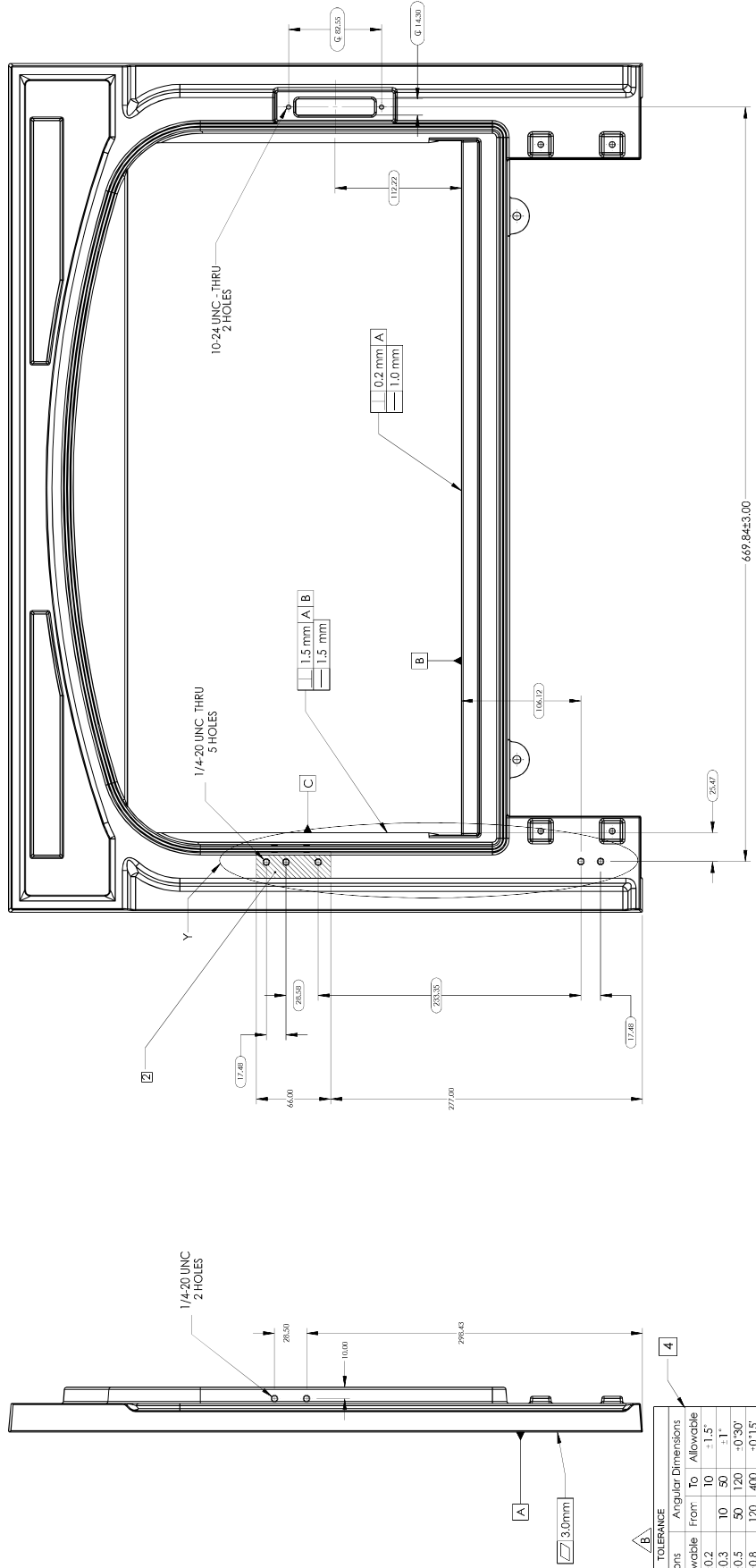

Linear Dimensions		Angular Dimensions	
From	To	From	To
0.5	3	-0.2	10
3	6	-0.3	50
6	30	-0.5	90
30	120	-0.8	120
120	400	-1.2	150
400	1000	-2	180
Chamfer Radius		From	To
		5	3
		3	6
		6	1
		1	2

UNLESS OTHERWISE NOTED OR SPECIFIED, ALL DIMENSIONS ARE TO BE HONED TO ±0.005 UNLESS OTHERWISE SPECIFIED. ALL DIMENSIONS ARE TO BE HONED TO ±0.005 UNLESS OTHERWISE SPECIFIED. ALL DIMENSIONS ARE TO BE HONED TO ±0.005 UNLESS OTHERWISE SPECIFIED.

**WOLF STEEL**  
WOLF STEEL INDUSTRIES, INC.  
10000 WOLF STEEL DRIVE  
MILWAUKEE, WI 53227  
TEL: 414-224-2200  
WWW.WOLFSTEEL.COM

**CASTING FRONT (TRADITIONAL)**  
MODEL: W135-0642  
THICKNESS: 15.30 LBS  
MATERIAL: GREY CAST IRON (HT150) SUITABLE FOR PORCELAIN ENAMEL  
FINISH: STONE BRIGHT HIGH TEMP METALLIC BLACK PAINT/ ENAMELED  
SCALE: 1:4  
SHEET 3 OF 3  
DRAWN BY: HA  
CHECKED BY: CL

REVISION: F REV DATE: 12/4/2017 REV NOTE: UPDATED DRAWING TEMPLATE / ADDED NOTE

**NOTES:**

- 1 ALL DRAFT ANGLES 5° UNLESS OTHERWISE STATED
- 2 DRAWING DOES NOT CONTAIN SUFFICIENT DETAILS TO DEVELOP TOOLING
- 3 WOLF STEEL APPROVED CAD MODEL IS REQUIRED
- 4 CLASS A SURFACES
- 5 CLASS A SURFACE FINISH BETWEEN Ra 6.3 - 12.5 (RMS 275 - 500)
- 6 C DENOTES CRITICAL INSPECTION CRITERIA
- 7 TOLERANCE SHOWN WITHIN REFERENCED DIMENSION BUBBLE IS ONLY APPLICABLE TO PORCELAIN ENAMELED PARTS
- 8 D

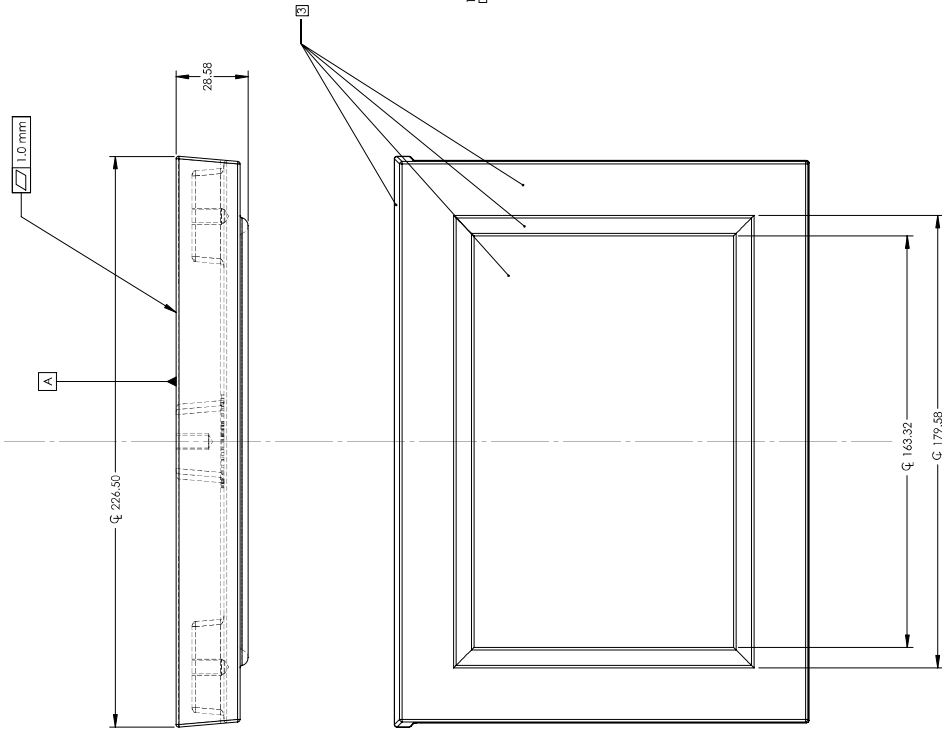

TOLERANCE		Angular Dimensions		
Linear Dimensions	From To Allowable	From To Allowable	From To Allowable	
0.5	3	+0.2	10	±1.5°
3	6	+0.3	10	±1°
6	30	+0.5	50	±0°30'
30	120	+0.8	120	±0°15'
120	400	±1.2	Chamfer Radius	
400	1000	±2	From To Allowable	
			5	±0.4
			6	±2

ABSTRACT ISO 2768

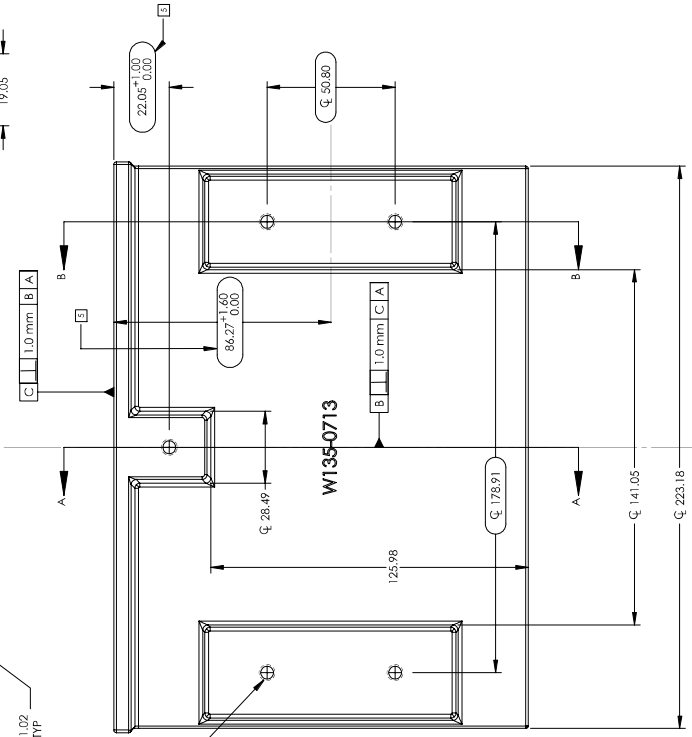
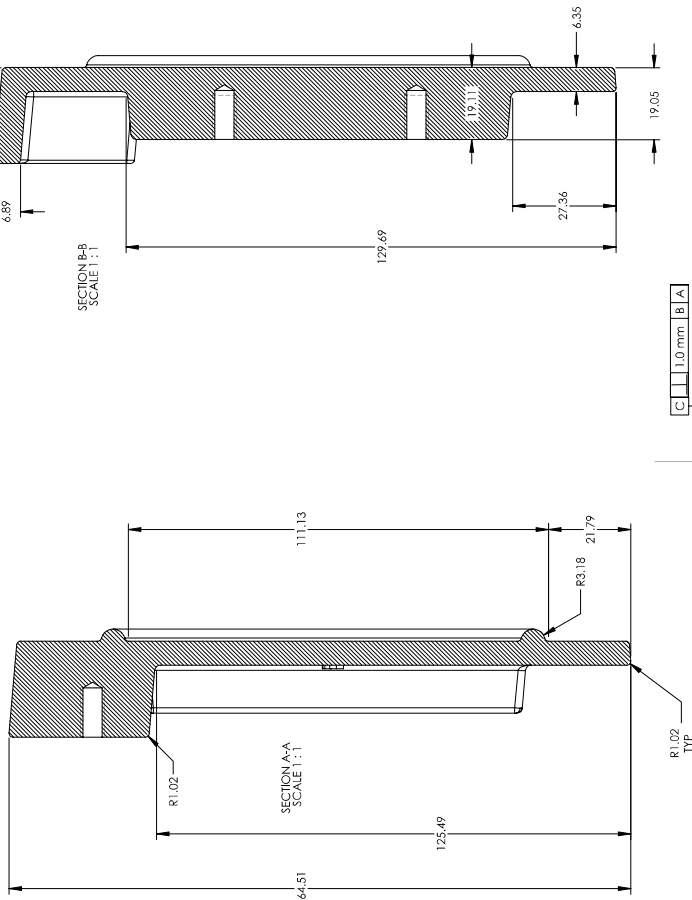

**WOLF STEEL** LTD.  
 WOLF STEEL (USA) INC.  
 10000 WOLF STEEL DRIVE, WOLF STEEL, OHIO 44095-1000  
 TEL: 440.353.3333 FAX: 440.353.3334  
 WWW.WOLFSTEEL.COM

**UNLESS OTHERWISE NOTED OR SPECIFIED ALL DIMENSIONS ARE OUTSIDE UNLESS OTHERWISE NOTED**  
**ALL SURFACES ARE CONSIDERED CLASS A**  
**REVISIONS SHALL BE MADE IN ACCORDANCE WITH THE SURFACE FINISH SPECIFICATION**  
 DIMENSIONS: ±0.13 ANGLES: ±1°  
 REFERENCE DIMENSIONS: ±0.8 RADIIUS: ±0.25

**CASTING, CENTER SECTION (TRADITIONAL)**  
 MODEL: W135-0713  
 TITLE: GREY CAST IRON (HTI50) SUITABLE FOR PORCELAIN ENAMEL  
 MATERIAL: STONE BRIGHT HIGH TEMP METALLIC BLACK PAINT / ENAMELED  
 FINISH: SCALE: 1:1.5 SHEET 1 OF 1 INVOICE/PO/RY: 3/11/2017  
 REF. DRAWING: 6.055.18  
 EPT3 DRAWING: W135-0713  
 DRAWN BY: 11/03/2017  
 CHECKED BY: 11/03/2017  
 REVISION: E 11/30/17 UPDATED PART FINISH FOR ACCURACY





- NOTES:
- 1 ALL DRAFT ANGLES 5° UNLESS OTHERWISE STATED
  - 2 DRAWING DOES NOT CONTAIN SUFFICIENT DETAILS TO DEVELOP TOOLING
  - 3 WOLF STEEL APPROVED CAD MODEL IS REQUIRED
  - 4 DENOTES CRITICAL INSPECTION CRITERIA

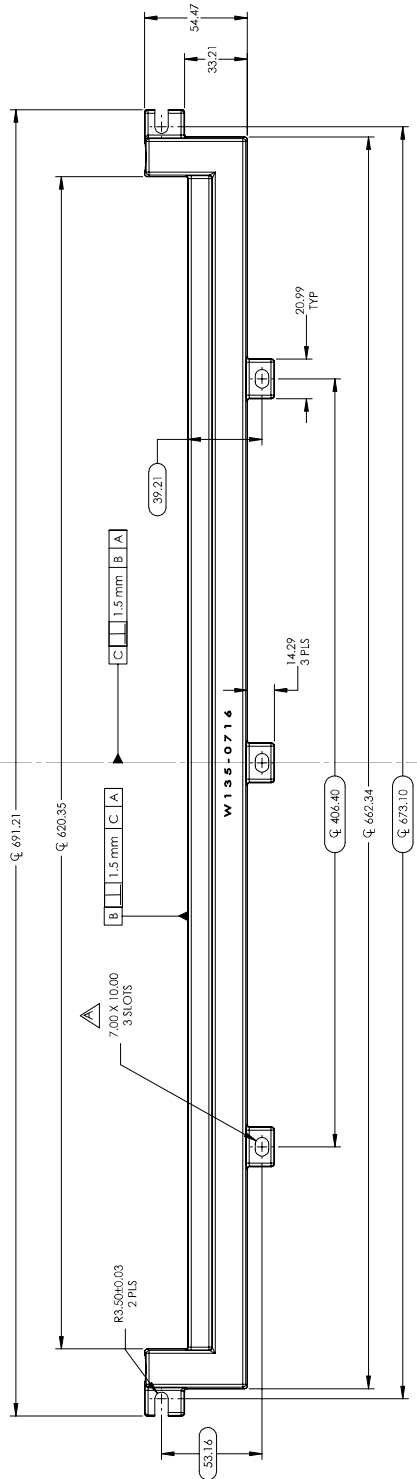
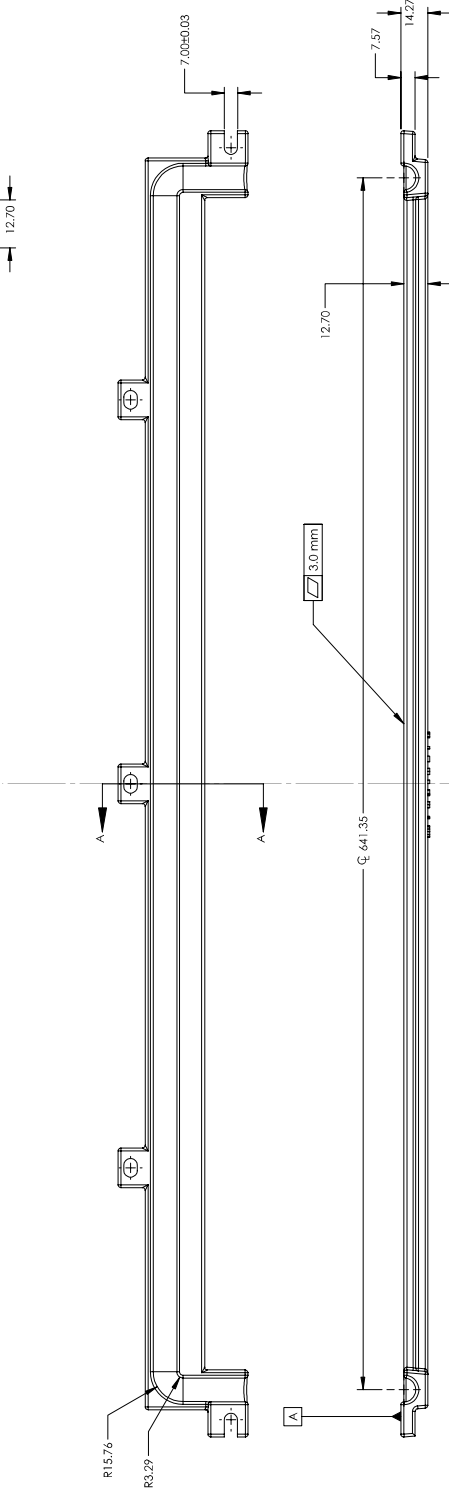
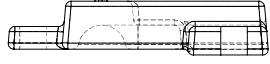
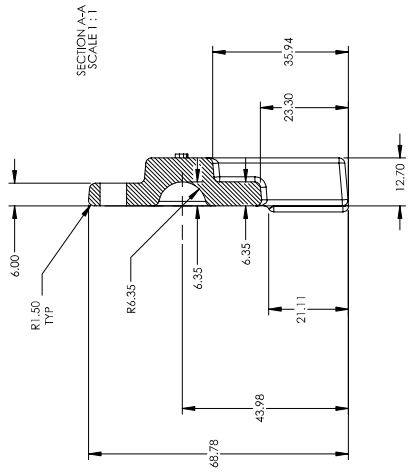

TOLERANCE		Angular Dimensions			
Linear Dimensions	From	To	Allowable		
0.5	3	+0.2	10	+1.5*	
3	6	+0.3	10	50	+1.1*
6	30	+0.5	50	120	+0.30*
30	120	+0.8	120	400	+0.15*
120	400	+1.2	Chamber Radius		
400	1000	+2	From	To	Allowable
			5	3	+0.4*
			6	6	±1
			6	6	±2

ABSTRACT ISO 2768

UNLESS OTHERWISE NOTED OR SPECIFIED ALL DIMENSIONS ARE OUTSIDE UNLESS OTHERWISE SPECIFIED. ALL SURFACES ARE CONSIDERED CLASS 2. SURFACE FINISH CRITERIA: DIMENSIONS: ±0.03 ANGLES: ±0.05 TOLERANCES: ±0.05

**WOLF STEEL LTD.**  
 WOLF STEEL APPLIANCE CORPORATION

TITLE: **CASTING, GLASS RETAINER (REPLACES W135-0492)**  
 MATERIAL: GREY CAST IRON (HTI50) SUITABLE FOR PORCELAIN ENAMEL  
 FINISH: STONE BRIGHT HIGH TEMP METALLIC BLACK PAINT  
 REFERENCE: W135-0492 FOR SURFACE FINISH CRITERIA

MODEL: EPI3 DRAWING: **W135-0716**  
 REF: 1.33 No. DRAWN BY: **HA**  
 SCALE: 1:2 SHEET 1 OF 1 INDD/YYYY: **3/11/2017**  
 REVISION: **D 12/13/17** UPDATED PART FINISH TO MATCH OTHER CASTINGS

CHECKED BY: \_\_\_\_\_

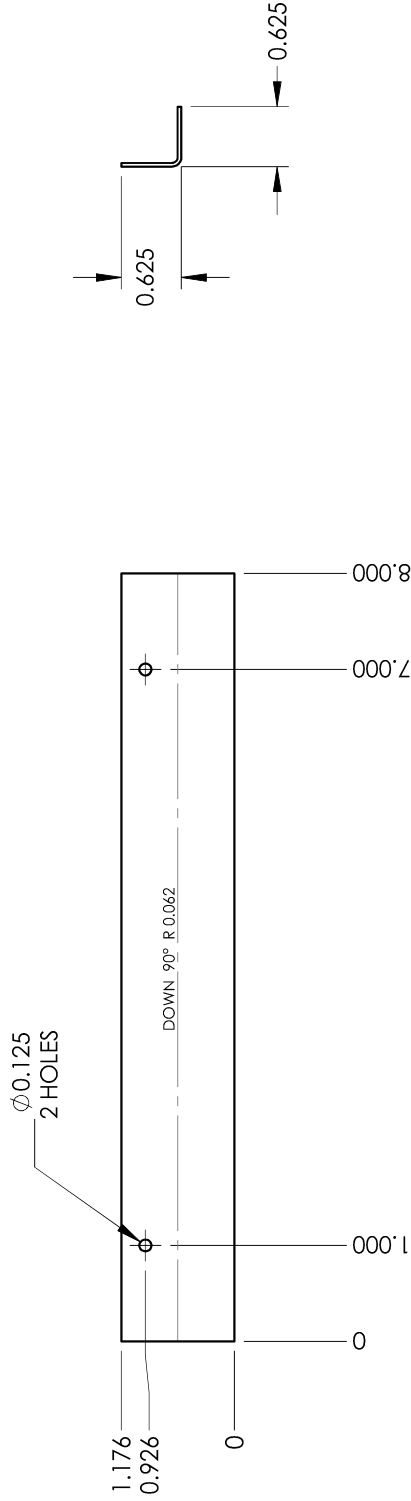

UNLESS OTHERWISE NOTED OR DEPICTED  
 ALL DIMENSIONS ARE OUTSIDE IN INCHES  
 UNLESS OTHERWISE SPECIFIED  
 WHERE APPLICABLE FLAT IS SHOWN FINISHED SIDE UP

TOLERANCES:  
 FORMED PARTS ±0.031"  
 BURNED PARTS ±0.063"  
 SURFACE DIMENSIONS ±.2°  
 ANGLES

**WOLF STEEL**  
**NAC**  
 NORTH AMERICAN  
 CHANNELS  
 CORPORATION

TITLE:	CHANNEL, AIR (TOP)	MODEL:	EP13	DRAWING:	W150-0061
MATERIAL:	20 GA GALVANNEAL	THICKNESS:	0.039	DRAWN BY:	A.RIGDEN
FINISH:		SCALE:	1:2	MM/DD/YYYY:	6/13/2012
REVISION:	-			CHECKED BY:	R.TJART
		0.104 LBS			

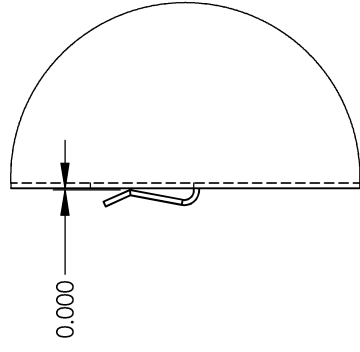

DETAIL A  
SCALE 1:1

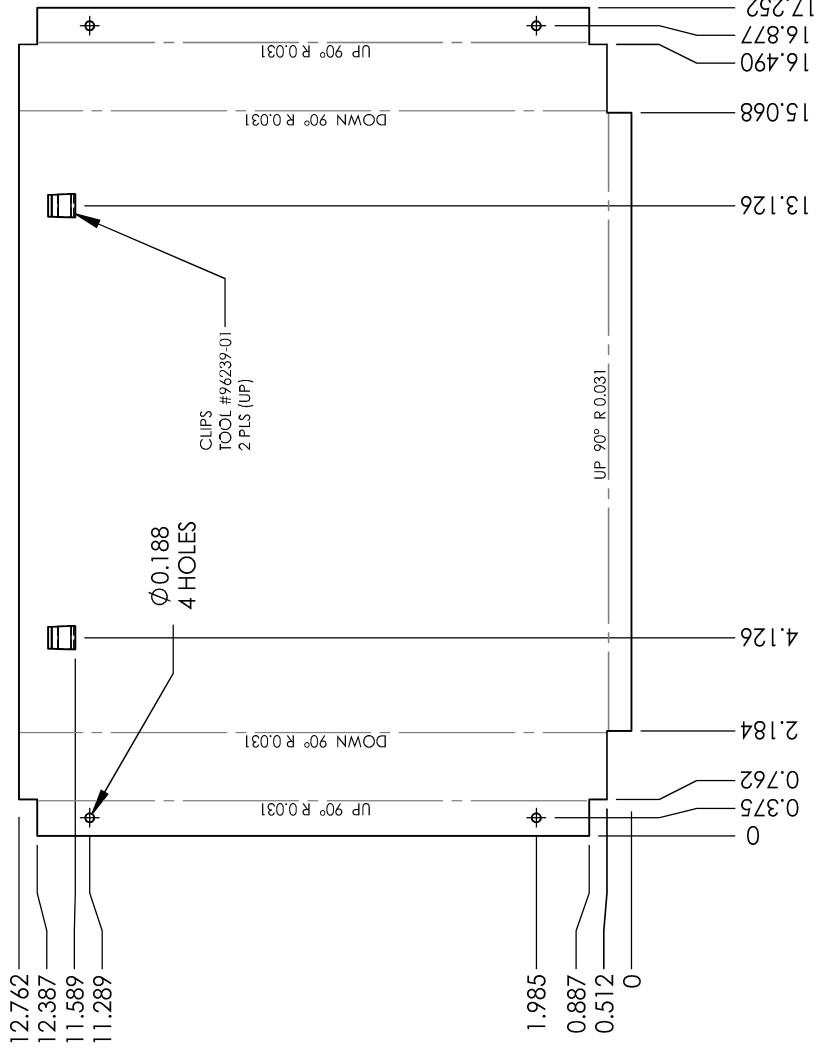
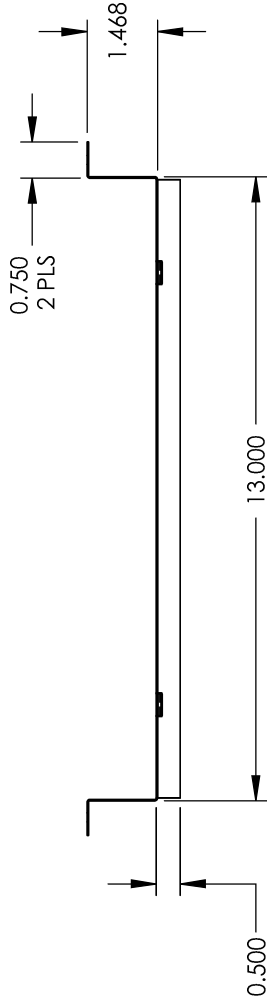

<p>UNLESS OTHERWISE NOTED OR DEPICTED ALL DIMENSIONS ARE OUTSIDE IN INCHES UNLESS OTHERWISE NOTED OTHERWISE WHERE APPLICABLE FLAT IS SHOWN FINISHED SIDE UP</p> <p>TOLERANCES: FORMED PARTS ±0.031" BURNED PARTS ±0.005" SURFACE DIMENSIONS ±2° ANGLES</p>	TITLE:	CHANNEL, BLOWER AIR	MODEL:	EP13	DRAWING:	W150-0063
	MATERIAL:	24 GA GALVANNEAL	THICKNESS:	0.027	DRAWN BY:	A.RIGDEN
	FINISH:		SCALE:	1:4	SHEET 1 OF 1	6/13/2012
	REVISION:	A	1/30/2013	(AGR) ADD CLIPS	CHECKED BY:	R.TJART

This drawing is the property of Wolf Steel LTD. or NAC. It is to be used only for the project and location specified hereon without our consent. All rights are reserved.

10109.12 AR



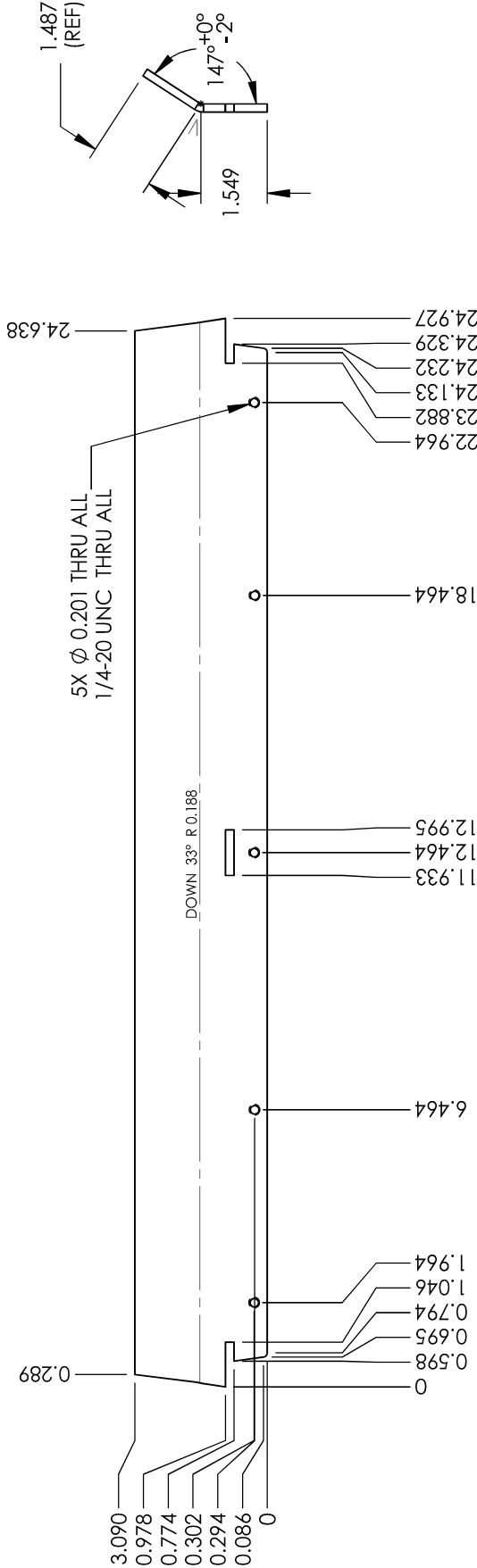
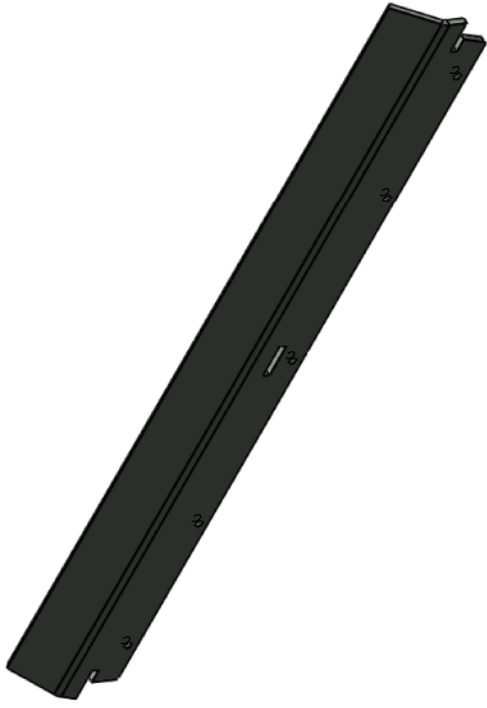

<p>120617 BY G</p> <p>This drawing is the property of Wolf Steel Ltd. or NCC. It is not to be used in any manner without our consent. All rights are reserved.</p> <p><b>WOLF STEEL™</b></p>	<p><b>TOLERANCES:</b> UNLESS OTHERWISE NOTED OR DEPICTED ALL DIMENSIONS ARE OUTSIDE IN INCHES ALL SURFACES ARE CONSIDERED CLASS "D"</p> <p>DIMENSIONS ±0.062 REFERENCE DIMENSIONS ±0.125</p> <p>RADIUS ±0.062 ANGLES ±2</p>	<p><b>TITLE:</b> CHANNEL, AIR WASH</p> <p><b>MATERIAL:</b> 3/16 HR P&amp;O</p> <p><b>FINISH:</b></p>	<p><b>MODEL:</b> EP13-1</p> <p><b>THICKNESS:</b> 0.188</p> <p><b>SCALE:</b> 1:4</p>	<p><b>DRAWING:</b> W150-0064</p> <p><b>ISSUE DATE:</b> 06/13/12</p> <p><b>SHEET 1 OF 1</b></p>
	<p><b>PROJECT LEAD:</b> P HODGES</p> <p><b>REV DATE:</b> 6/19/2018</p> <p><b>REV NOTE:</b></p>	<p><b>3.950 LBS</b></p> <p><b>CN#:</b></p>	<p><b>CHECKED BY:</b> UNRELEASED</p>	<p><b>DRAWN BY:</b> UNRELEASED</p>

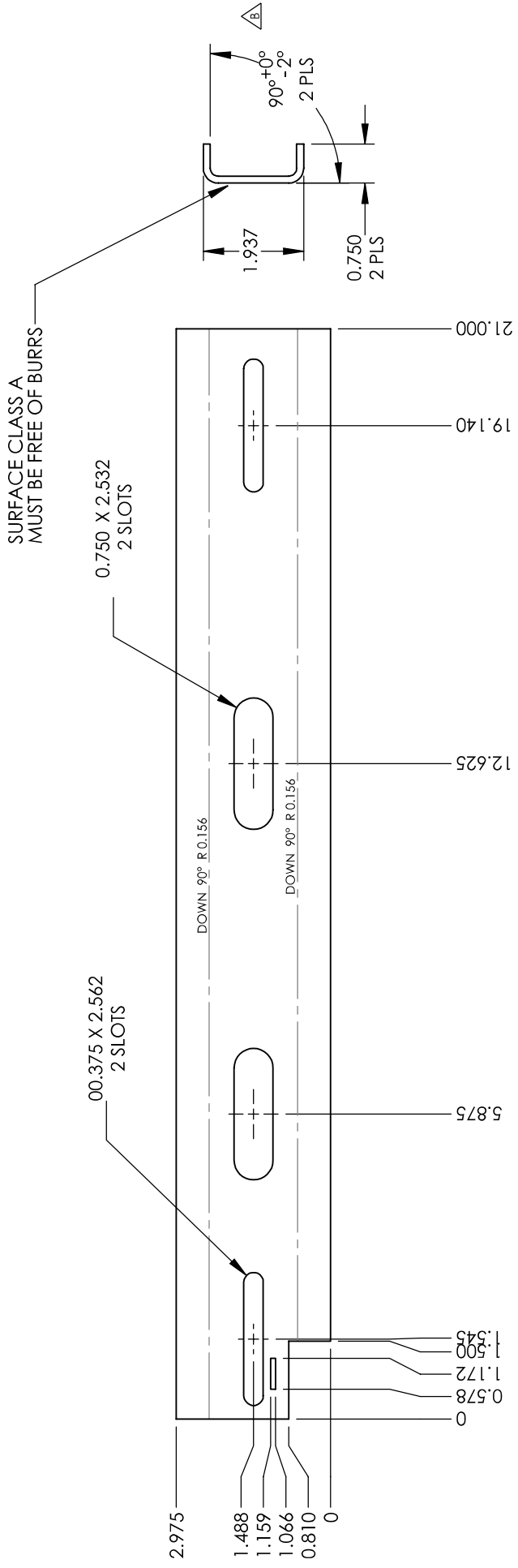

<p>UNLESS OTHERWISE NOTED OR DEPICTED ALL DIMENSIONS ARE OUTSIDE IN INCHES</p> <p>TOLERANCES: WHERE APPLICABLE, FLAT IS SHOWN FINISHED SIDE UP</p> <p>FORMED PARTS ±0.031" BLANKED PARTS ±0.010" REFERENCE DIMENSIONS ±0.063" ANGLES ±2°</p>		<p>TITLE: <b>CONTROL, AIR</b></p> <p>MATERIAL: 10 GA SS 304-2B<math>\Delta</math></p> <p>FINISH:</p> <p>REVISION: <b>B</b> 05/24/13 (AGR) ADD DIM&amp;TOLERANCE</p>	<p>MODEL: EP13</p> <p>THICKNESS: 0.135</p> <p>SCALE: 1:3</p>	<p>DRAWING: <b>W190-0043</b></p> <p>DRAWN BY: <b>A.RIGDEN</b></p> <p>MM/DD/YYYY: 06/13/12</p> <p>CHECKED BY: R.TJART</p>
--	--	---	--	--



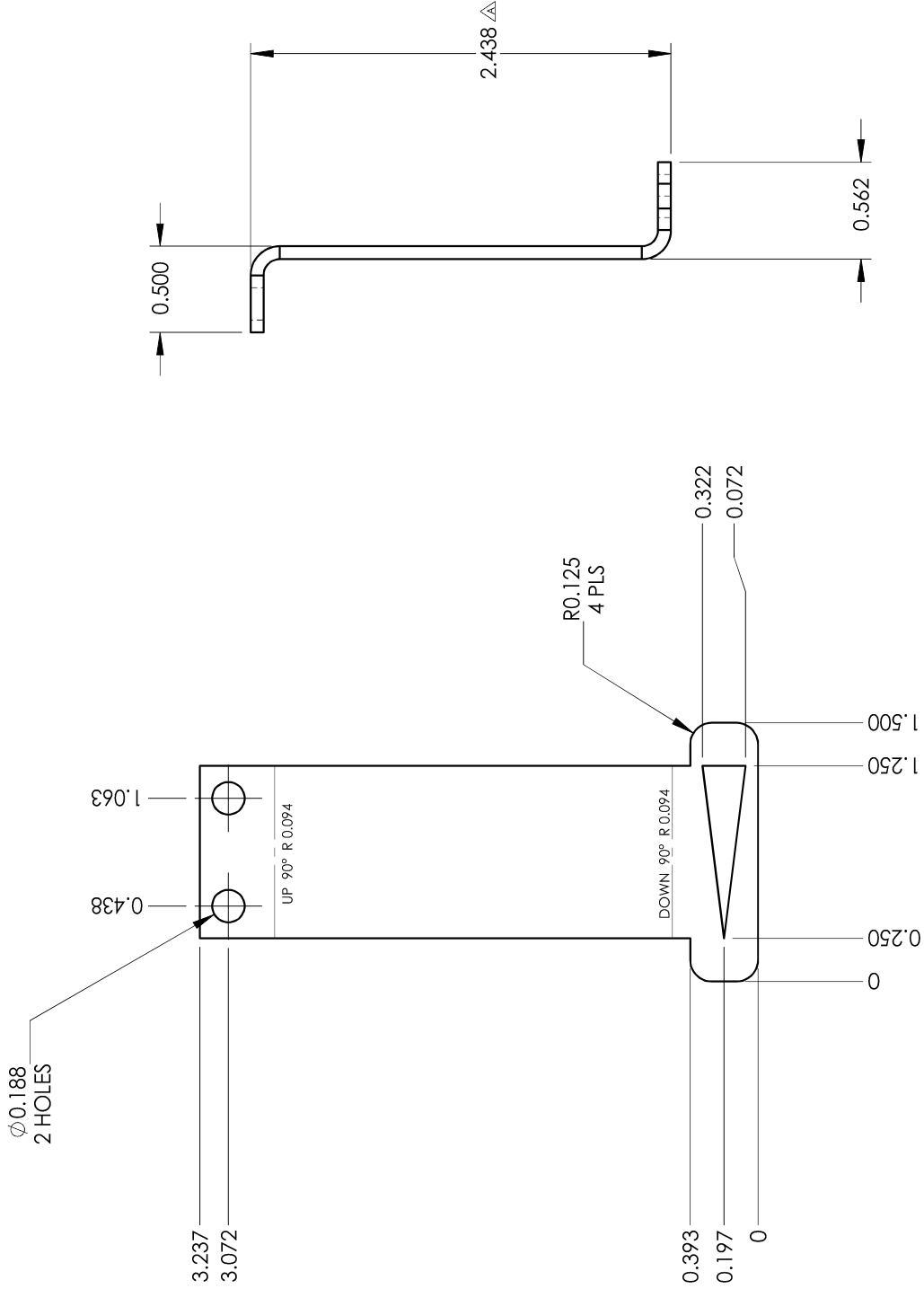

UNLESS OTHERWISE NOTED OR DEPICTED  
 ALL DIMENSIONS ARE OUTSIDE IN INCHES  
 UNLESS OTHERWISE NOTED OTHERWISE  
 WHERE APPLICABLE FLAT IS SHOWN FINISHED SIDE UP

**TOLERANCES:**  
 FORMED PARTS ±0.031"  
 BEVELLED PARTS ±0.009"  
 SURFACE FINISH DIMENSIONS ±2°  
 ANGLES



This drawing is the property of Wolf Steel LTD., or NAC.  
 It is to be used only for the specific part identified  
 without our consent. All rights are reserved.

**WOLF STEEL**<sup>TM</sup>  
**NAC**  
 Precision Steel  
 Components

TITLE:	<b>CONTROL, AIR INDICATOR</b>	MODEL:	EPI3T	DRAWING:	<b>W190-0052</b>
MATERIAL:	14 GA HR P&O	THICKNESS:	0.075	DRAWN BY:	<b>A.RIGDEN</b>
FINISH:		SCALE:	1:1	MM/DD/YYYY:	<b>6/13/2012</b>
REVISION:	<b>A</b>	(AGR) ADD MATERIAL		CHECKED BY:	<b>R.TJART</b>
		0.068 LBS			



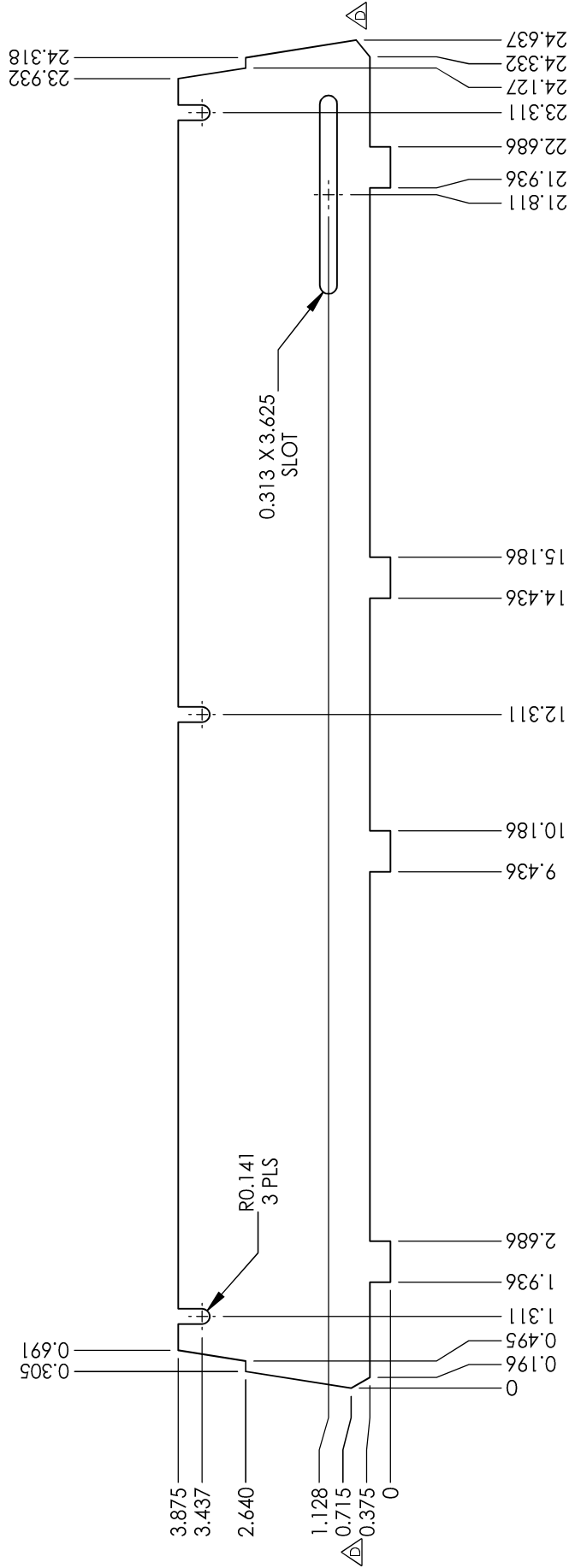

<p>UNLESS OTHERWISE NOTED OR DEPICTED ALL DIMENSIONS ARE OUTSIDE IN INCHES DIMENSIONS IN PARENTHESES ARE IN MILLIMETERS WHERE APPLICABLE FLAT IS SHOWN FINISHED SIDE UP</p>		<p>TITLE: <b>COVER, AIR CONTROL</b></p>		<p>MODEL: EP13</p>		<p>DRAWING: <b>W200-0411</b></p>	
<p>TOLERANCES: FORMED PARTS ±0.031" BURNED PARTS ±0.003" SURFACE DIMENSIONS ±.2°</p>		<p>MATERIAL: 18 GA ALUMINIZED</p>		<p>THICKNESS: 0.051</p>		<p>DRAWN BY: <b>A.RIGDEN</b></p>	
<p>REVISION: <b>D</b></p>		<p>DATE: <b>9/27/2013</b></p>		<p>SCALE: 1:3</p>		<p>SHEET 1 OF 1</p>	
<p>(AGR) ADD RELIEFS</p>		<p>WEIGHT: 1.207 LBS</p>		<p>DATE: <b>6/13/2012</b></p>		<p>CHECKED BY: <b>R.TJART</b></p>	



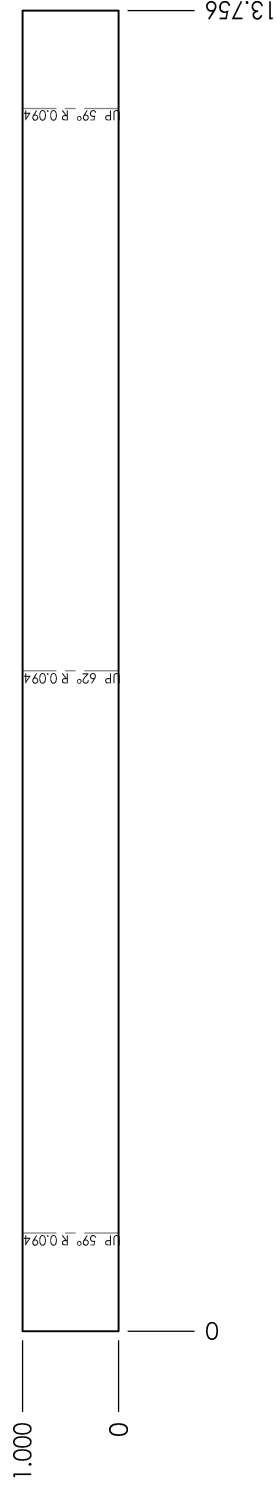
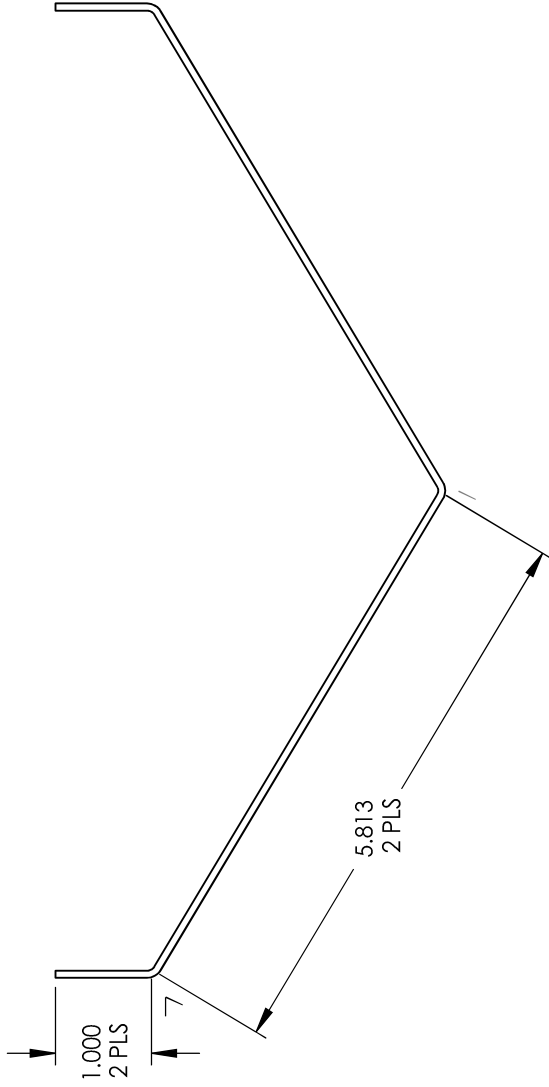

<p><small>This drawing is the property of Wolf Steel LTD. or NAC. It is to be used only for the specific part identified herein without our consent. All rights are reserved.</small></p> <p><b>WOLF STEEL<sup>TM</sup></b>  <b>NAC</b> <small>Manufactured in Canada</small></p>		<p><b>UNLESS OTHERWISE NOTED OR DEPICTED ALL DIMENSIONS ARE OUTSIDE IN INCHES</b></p> <p><b>TOLERANCES:</b>          WHERE APPLICABLE, FLAT IS SHOWN FINISHED SIDE UP          FORMED PARTS ±0.031"          BLANKED PARTS ±0.010"          REFERENCE DIMENSIONS ±0.063"          ANGLES ±2°</p>	<p><b>TITLE:</b> DEFLECTOR, BLOWER AIR</p> <p><b>MATERIAL:</b> 14 GA HR P&amp;O</p> <p><b>FINISH:</b></p> <p><b>REVISION:</b> -</p>	<p><b>MODEL:</b> EP13</p> <p><b>THICKNESS:</b> 0.287 LBS</p> <p><b>SCALE:</b> 1:2</p>	<p><b>DRAWING:</b> W215-0158</p> <p><b>DRAWN BY:</b> A.RIGDEN</p> <p><b>MM/DD/YYYY:</b> 6/13/2012</p> <p><b>SHEET 1 OF 1</b></p> <p><b>CHECKED BY:</b> R.TJART</p>
---	--	--	---	---	--

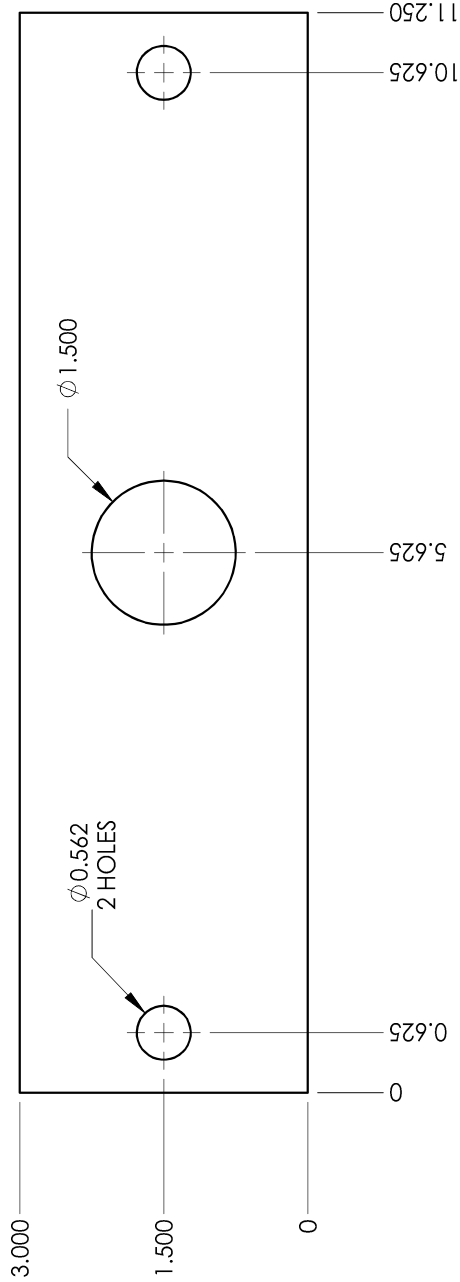

The drawing is the property of Wolf Steel Ltd. or NAC. It is to be used only for the specific project and without our consent. All rights are reserved.

**WOLF STEEL**<sup>TM</sup>  
**NAC**  
 Precision in  
 Architecture  
 Construction

UNLESS OTHERWISE NOTED OR DEPICTED  
 ALL DIMENSIONS ARE OUTSIDE IN INCHES  
 ALL SURFACES ARE CONSIDERED CLASS 10

**TOLERANCES:**  
 DIMENSIONS ±0.003"  
 REFERENCE DIMENSIONS ±0.125"  
 ANGLES ±2°

**TITLE:** GASKET, S/A CHAMBER  
**MATERIAL:** 1/8" CERAMIC FIBRE PAPER (2150°F)  
**FINISH:**  
**REVISION:** -

**MODEL:** EP13  
**DRAWING:** W290-0215  
**DRAWN BY:** A.RIGDEN  
**SCALE:** 1:2  
**SHEET 1 OF 1**  
**MM/DD/YYYY:** 6/13/2012  
**CHECKED BY:** R.TJART

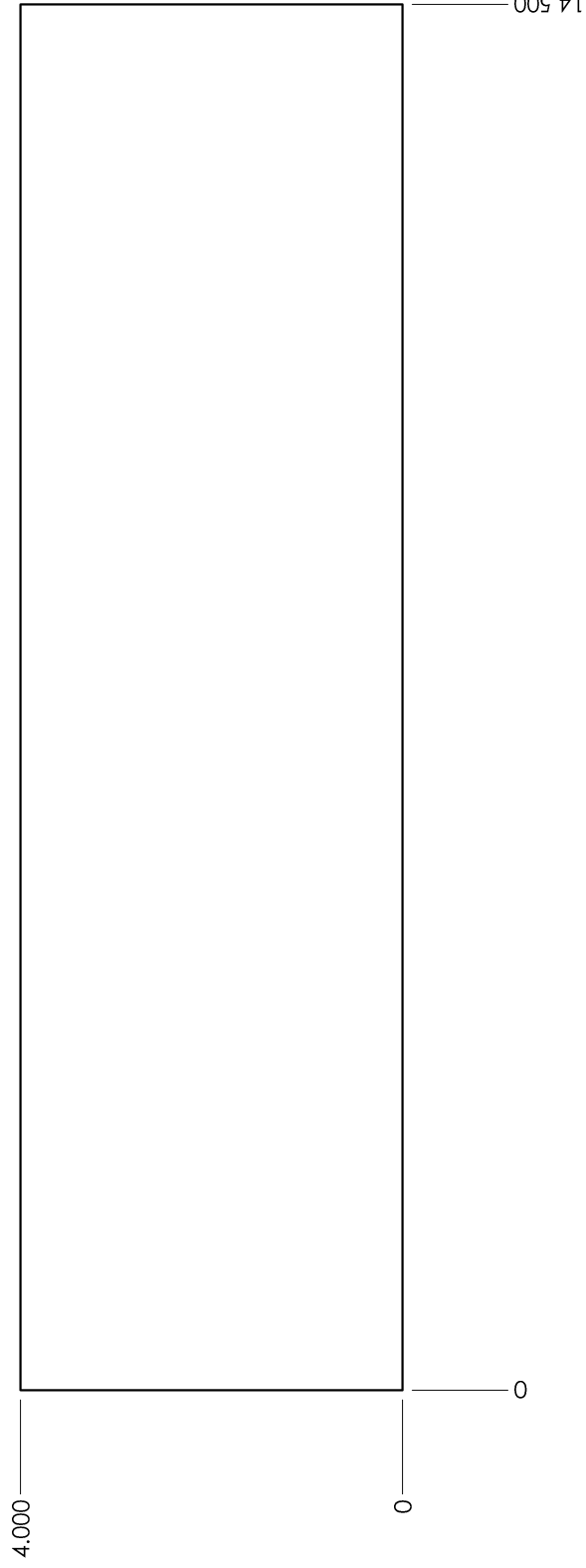

<small>UNLESS OTHERWISE NOTED OR DEPICTED, ALL DIMENSIONS ARE OUTSIDE UNLESS OTHERWISE SPECIFIED. ALL SURFACES ARE CONSIDERED CLASS 'D' REFER TO ENG-009 AND ENG-010 FOR SURFACE FINISH CRITERIA</small> <b>TOLERANCES:</b> DIMENSIONS: +0.063 RADIUS ± 0.031 REFERENCE DIMENSIONS: ± 0.125 ANGLES ± 2	<b>TITLE:</b> GASKET, BLOWER VIBRATION DAMPER	<b>MODEL:</b> EP13	<b>DRAWING:</b> W290-0229
	<b>MATERIAL:</b> 1/8" FIBERGLASS PAPER	<b>SCALE:</b> 1:2	<b>DRAWN BY:</b> A.RIGDEN
<b>FINISH:</b>	<b>REVISION:</b> ~	<b>SHEET 1 OF 1</b>	<b>CHECKED BY:</b> R.TJART

This drawing is the property of Wolf Steel Ltd. or NAC. It is to be used only for the project and without our consent. All rights are reserved.  
  
**WOLF STEEL**<sup>TM</sup>  
**NAC**  
Manufactured in Canada



NOTES:

- CERAMIC GLASS SHOULD WITHSTAND TEMPERATURE OF 560 °C CONTINUOUSLY AS PER DIN EN 1748-2 STANDARD.
- VISUAL AND DIMENSIONAL TOLERANCES MUST COMPLY WITH SPECIFICATIONS OUTLINED IN WOLF STEEL LTD. PROCESS CONTROL ENG-011

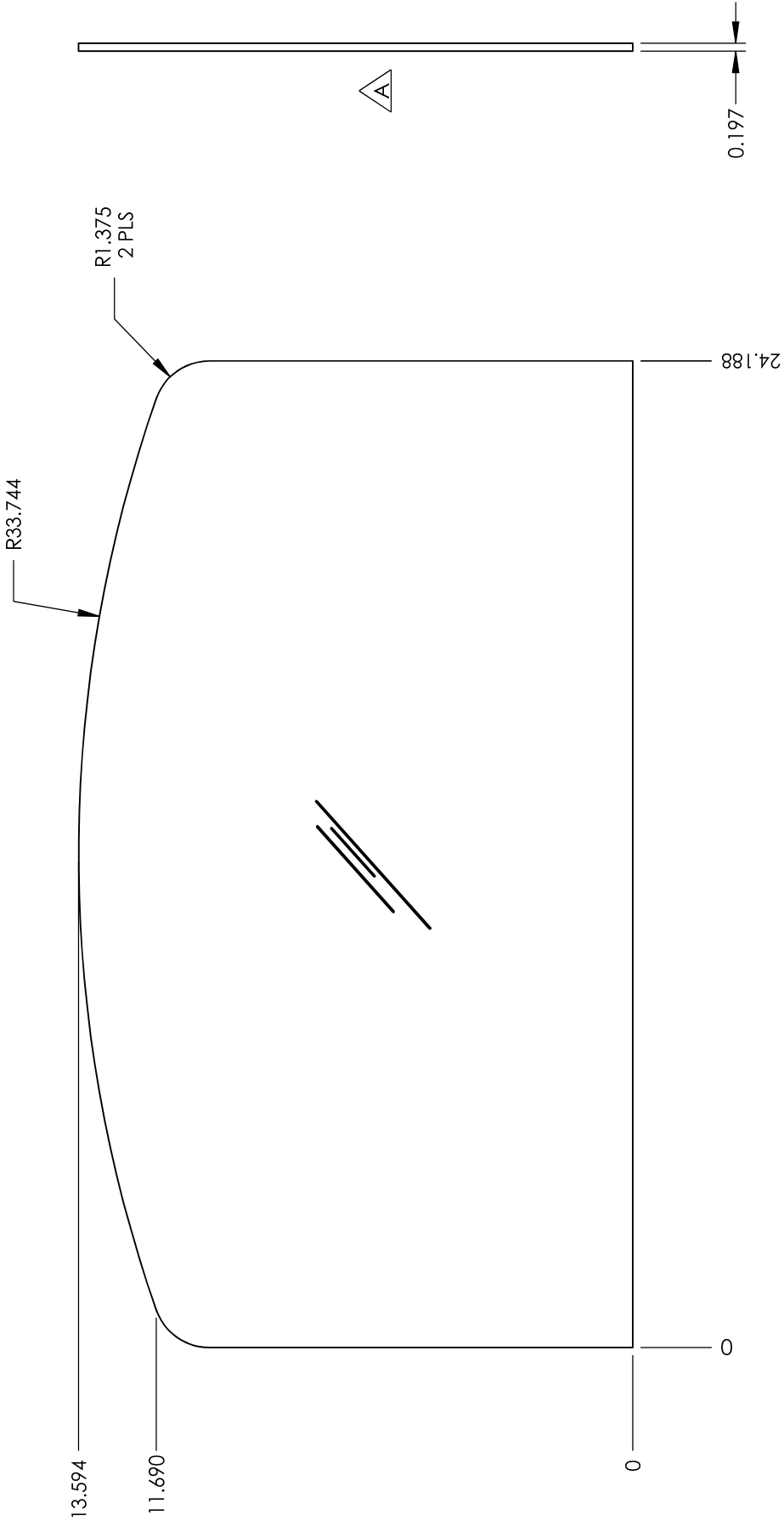

0.197

24.188

R1.375  
2 PLS

R33.744

13.594

11.690

0

O

This drawing is the property of Wolf Steel Ltd. or NCC. It is not to be used in any manner without our consent. All rights are reserved.		DATE FORWAT MM/DD/YY		DIMENSIONS REFERENCE DIMENSIONS ±0.062 ±0.125		TOLERANCES: UNLESS OTHERWISE NOTED OR DEPICTED ALL DIMENSIONS ARE OUTSIDE IN INCHES ALL SURFACES ARE CONSIDERED CLASS "D"		RADIUS ±0.062 ANGLES ±2		TITLE: <b>GLASS, 5MM X 13.594" X 24.188" CERAMIC</b>	MODEL:	EPI3T	DRAWING: <b>W300-0146</b>
		MATERIAL: CERAMIC GLASS	FINISH:	PROJECT LEAD:	REVISION: <b>A</b>	REV DATE: <b>05/03/18</b>	REV NOTE: UPDATED TOLERANCE BLOCK/ADDED SPEC NOTES/ADDED SIDE VIEW	5.429 LBS	THICKNESS:	0.197	ISSUE DATE: <b>06/13/2012</b>	SCALE: 1:4	SHEET 1 OF 1

- NOTES: 1. MUST BE USED IN CONJUNCTION WITH WOLF STEEL ENGINEERING APPROVED 3D MODEL  
 2. SHEET METAL INSERT MUST BE COMPLETELY FREE OF BURRS  
 3. HANDLE BARREL MATERIAL, BLACK, NYLON 66 PA66, AND MUST BE CAPABLE OF CONTINUOUS OPERATION AT 230°C  
 4. HANDLE BARREL MUST HAVE FLASH REMOVED/POLISHED

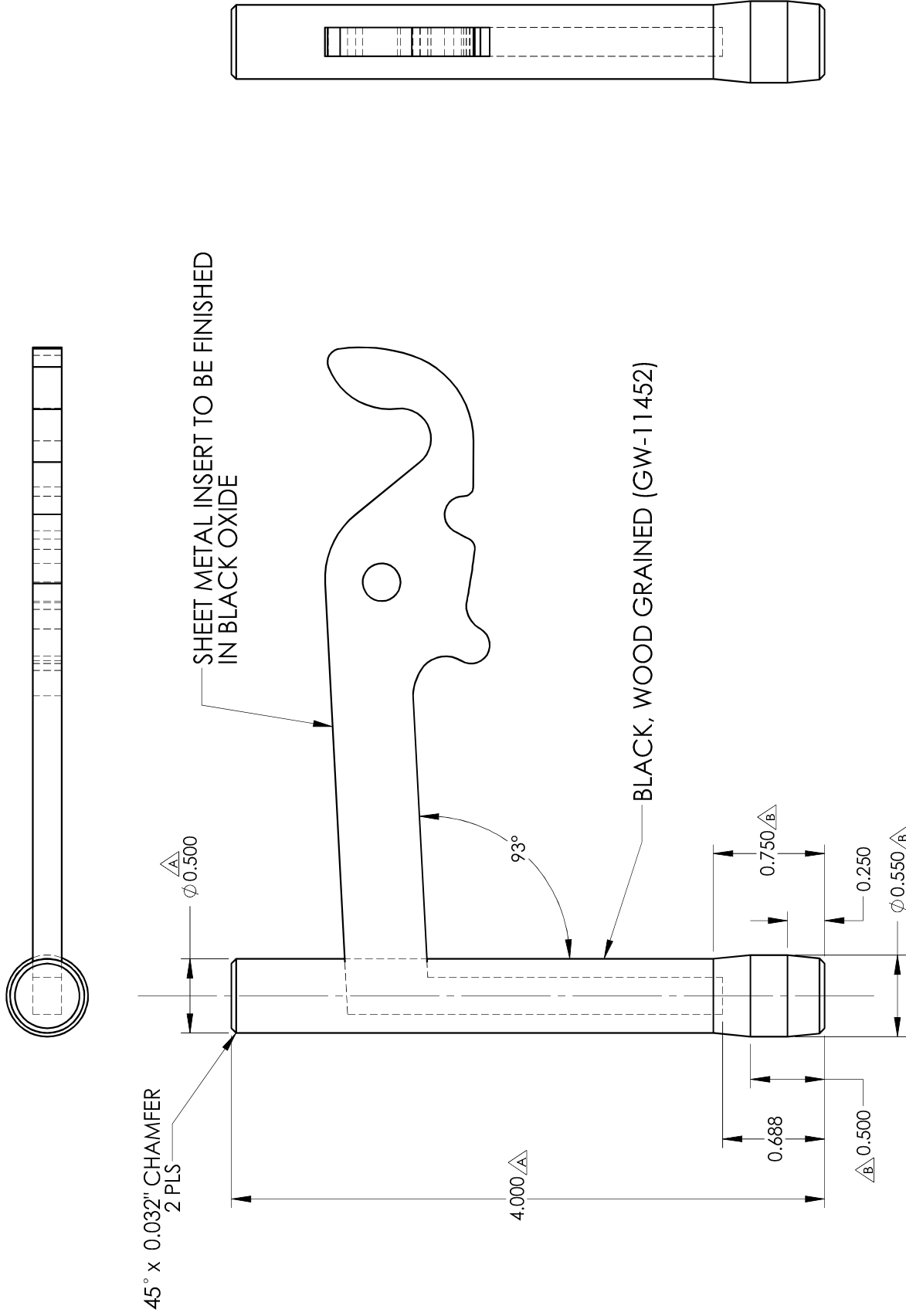

UNLESS OTHERWISE NOTED OR DEPICTED ALL DIMENSIONS ARE OUTSIDE IN INCHES ALL SURFACES ARE CONSIDERED CLASS "B"		TITLE:	HANDLE, EP13 DOOR	MODEL:	EP13	DRAWING:	W325-0077
DIMENSIONS REFERENCE DIMENSIONS ANGLES TOLERANCES: ±0.015" ±0.031" ±2°		MATERIAL:			0.210 LBS	DRAWN BY:	A.RIGDEN
		FINISH:			SCALE: 1:1	SHEET 1 OF 2	6/13/2012
		REVISION:	B	12/12/2012	(JMD) REVISED FOR BETTER FIT	CHECKED BY:	R.TJART

The drawing is the property of Wolf Steel LTD. or NAC. It is not to be used for any other purpose without our consent. All rights are reserved.

**WOLF STEEL**<sup>TM</sup>  
**NAC**  
 Precision in  
 Applied  
 Construction

10.09.12 AR

NOTES: 1. MUST BE USED IN CONJUNCTION WITH WOLF STEEL ENGINEERING APPROVED 3D MODEL  
 2. PART MUST BE COMPLETELY FREE OF BURRS

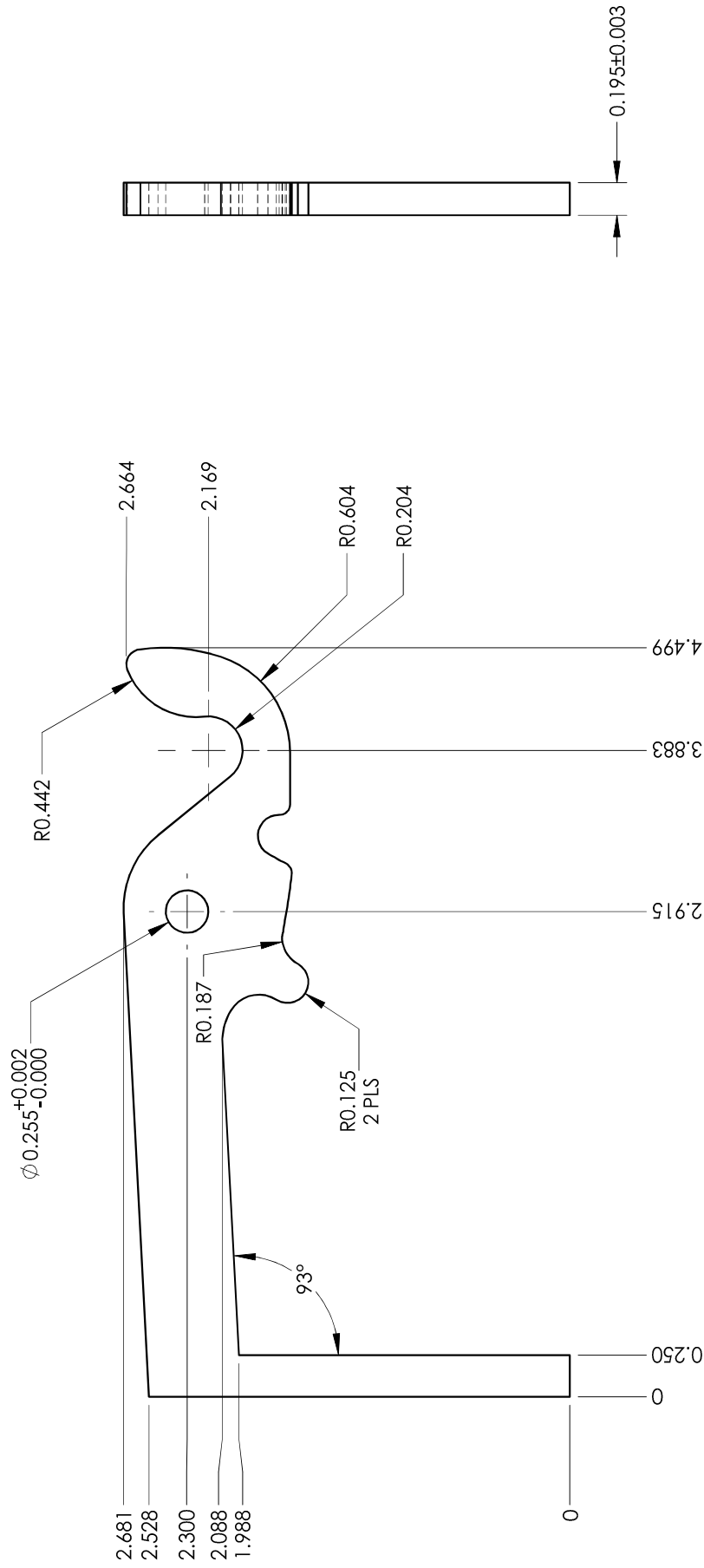

UNLESS OTHERWISE NOTED OR DEPICTED ALL DIMENSIONS ARE OUTSIDE IN INCHES ALL SURFACES ARE CONSIDERED CLASS "B"  TOLERANCES: ALL DIMENSIONS ±0.015"	TITLE:	<b>HANDLE, EP13 DOOR - SHEET METAL INSERT</b>	MODEL:	EP13	DRAWING:	<b>W325-0077</b>
	MATERIAL:	0.195" HR P&O		0.210 LBS	DRAWN BY:	<b>A.RIGDEN</b>
	FINISH:	BLACK OXIDE		SCALE: 1:1	MM/DD/YYYY:	<b>6/13/2012</b>
	REVISION:	<b>B</b>	<b>12/12/2012</b> (JMD) REVISED FOR BETTER FIT		CHECKED BY:	<b>R.TJART</b>

The drawing is the property of Wolf Steel LTD. or NAC.  
 It is to be used only for the project and for the part  
 identified on the drawing. All rights are reserved.

**WOLF STEEL**<sup>TM</sup>  
**NAC**  
 Precision in  
 Application  
 Commitment

10/09/12 AR

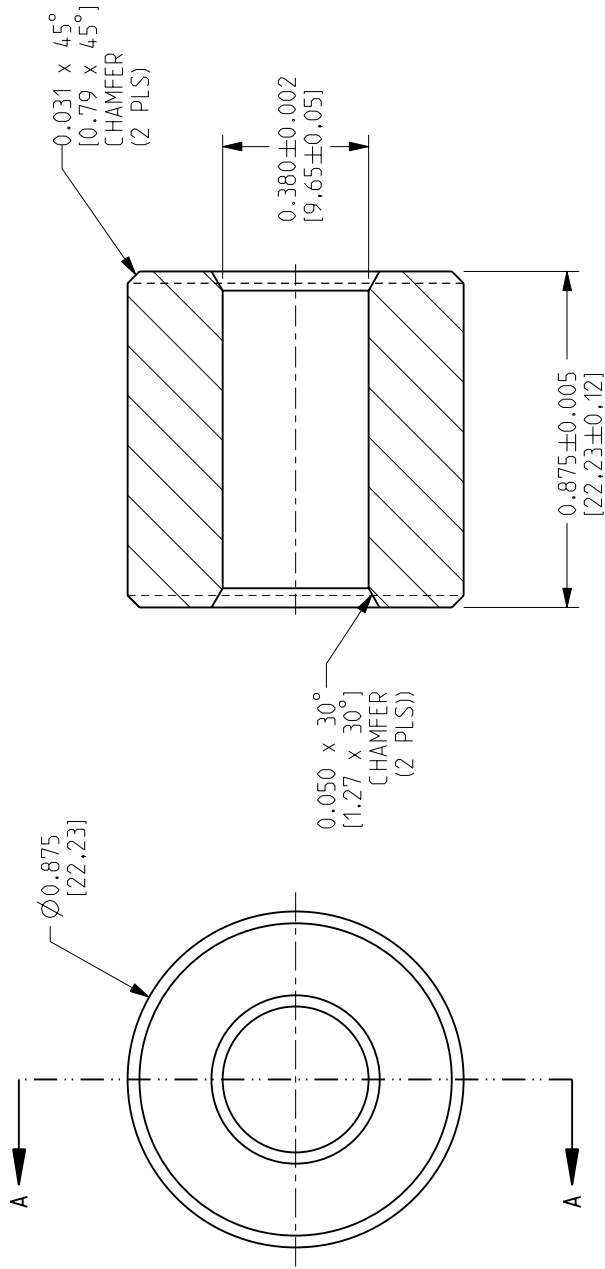

SECTION A-A

NOTE: DIMENSIONS IN BRACKETS ARE IN MM

**TOLERANCES:**  
 UNLESS OTHERWISE NOTED  
 WHERE APPLICABLE, FLAT IS SHOWN  
 FORMED PARTS ±0.031  
 BLANKED PARTS ±0.005  
 REFERENCE DIMENSION ±0.063  
 ANGLES ±2°

**WOLF STEEL LTD.**

SCALE	2.000
<b>DRAWING:</b>	<b>W330-0006</b>
<b>DRAWN BY:</b>	A. ZHANG
<b>DATE:</b>	03.19.93
<b>CHECKED BY:</b>	JFK

<b>TITLE:</b>	HINGE BUSHING
<b>MODEL:</b>	EPA
<b>MATERIAL:</b>	
<b>REVISION:</b>	F: 03.05.09 (AGR) FIX MODEL & ADD METRIC DIMS

NOTE: BREAK ALL EDGES

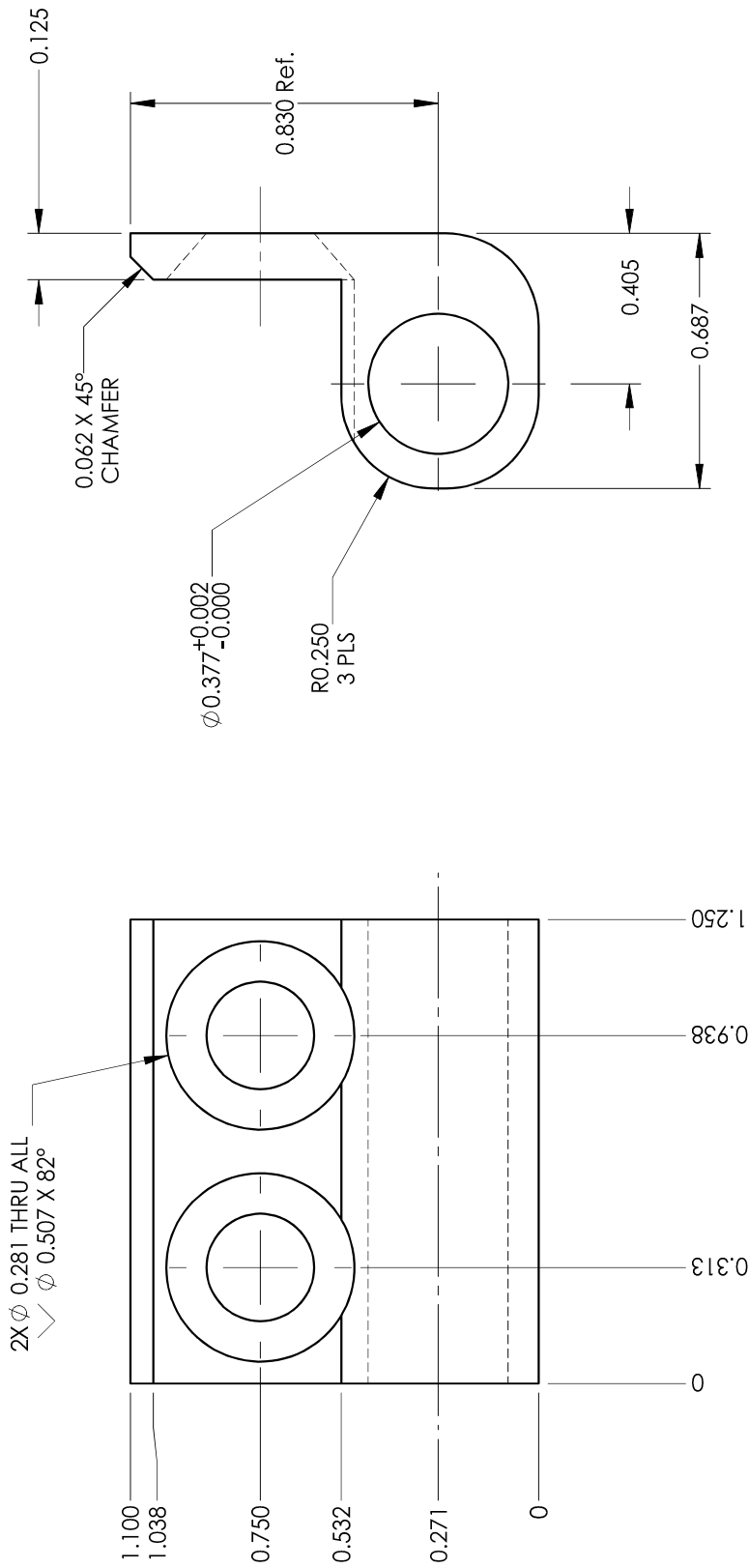

<p>UNLESS OTHERWISE NOTED OR DEPICTED ALL DIMENSIONS ARE OUTSIDE IN INCHES ALL SURFACES ARE CONSIDERED CLASS "B"</p>		<p>TITLE: HINGE, UPPER(EPI3 (C,T) DOOR), REPL W330-0083</p>	<p>MODEL: EPI3(C,T)</p>	<p>DRAWING: W330-0093</p>
<p>TOLERANCES:</p>		<p>MATERIAL: CRS</p>	<p>0.089 LBS</p>	<p>DRAWN BY: R.BARARI</p>
<p>DIMENSIONS ±0.005"</p>		<p>FINISH: BLACK OXIDE</p>	<p>SCALE: 2:1</p>	<p>MM/DD/YYYY: 05/04/2017</p>
<p>ANGLES ±1°</p>		<p>REVISION: ~</p>	<p>SHEET 1 OF 1</p>	<p>CHECKED BY: CLIFF</p>
<p>REFERENCE DIMENSIONS ±0.031"</p>				

The drawing is the property of Wolf Steel Ltd., or NAC. It is to be used only for the project and for the quantity specified. All rights are reserved.

**WOLF STEEL**<sup>TM</sup>  
**NAC**  
NORTH AMERICAN  
CORPORATION

10/09/12 AR

NOTE: BREAK ALL EDGES

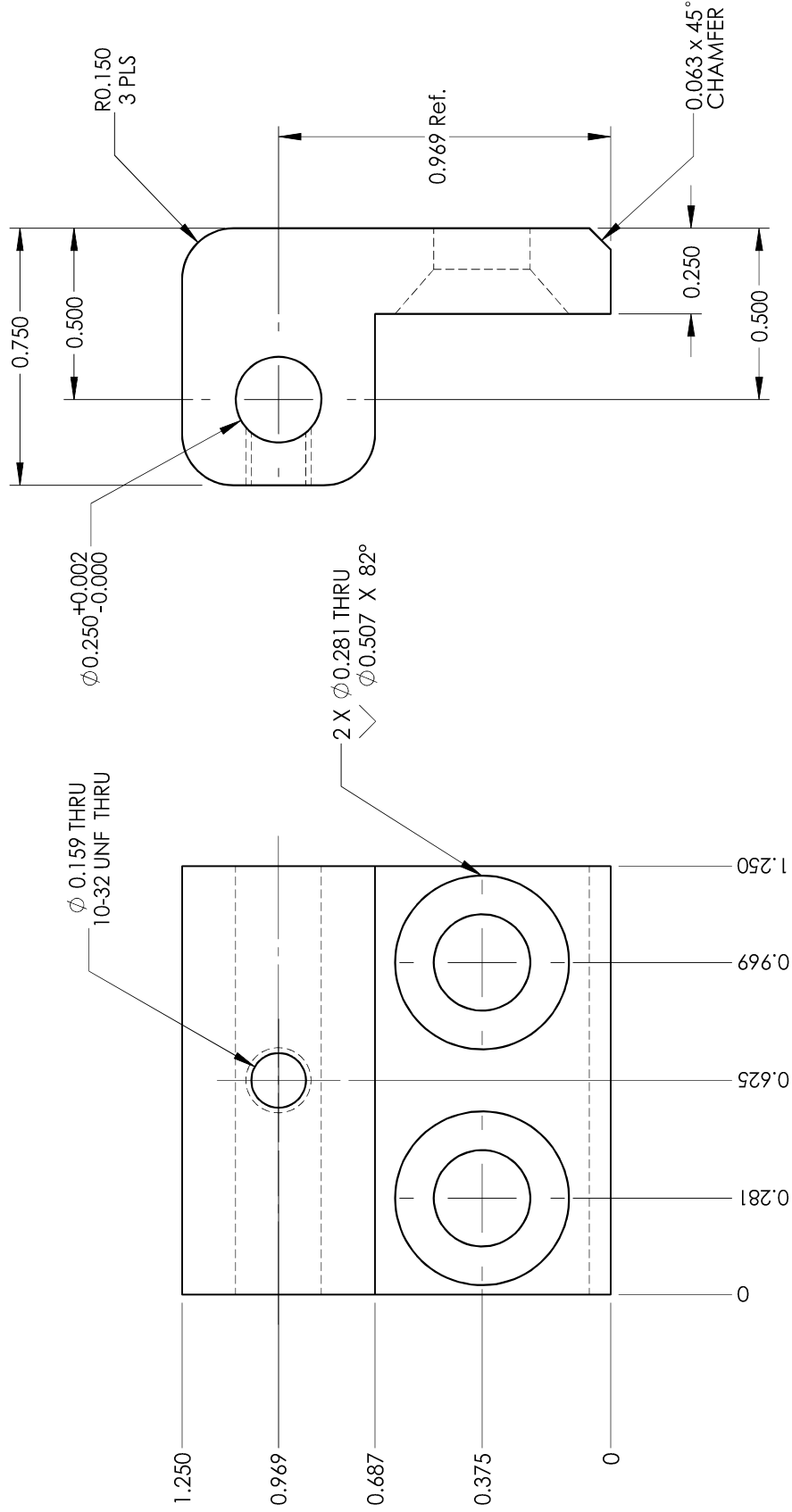

The drawing is the property of Wolf Steel Ltd. or NAC. It is to be used only for the project and order number stated. All rights are reserved.

**WOLF STEEL<sup>TM</sup>**  
**NAC**  
 Precision in  
 Castings

UNLESS OTHERWISE NOTED OR DEPICTED  
 ALL DIMENSIONS ARE OUTSIDE IN INCHES  
 ALL SURFACES ARE CONSIDERED CLASS "B"

**TOLERANCES:**  
 DIMENSIONS ±0.005"  
 ANGLES ±1°  
 REFERENCE DIMENSIONS ±0.031"

**TITLE:** HINGE, FRONT CASTING LOWER (REPL W330-0084)  
**MATERIAL:** CRS  
**FINISH:** BLACK OXIDE  
**REVISION:** ~

**MODEL:** 0.172 LBS  
**SCALE:** 2:1  
**SHEET 1 OF 1**

**DRAWING:** EPI3T  
**DRAWN BY:** R.BARARI  
**MM/DD/YYYY:** 05/04/2017  
**CHECKED BY:** CLIFF

NOTE: BREAK ALL EDGES

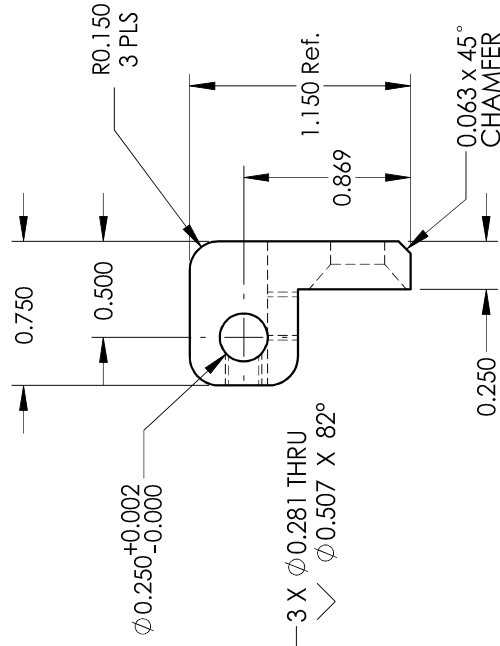
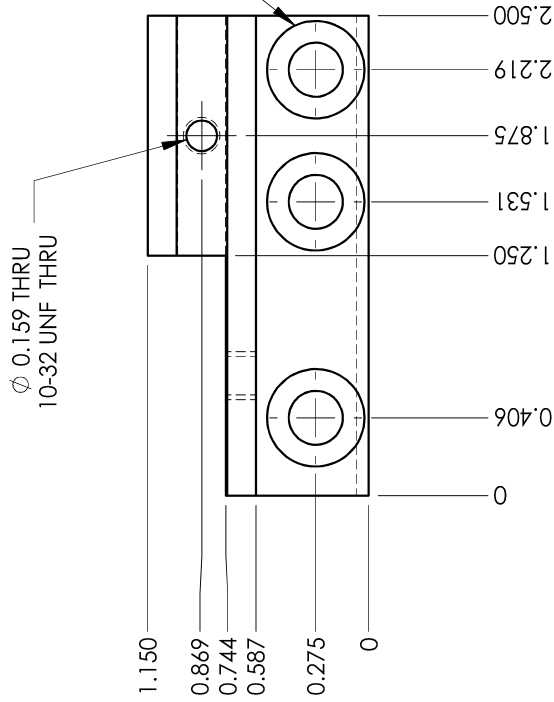
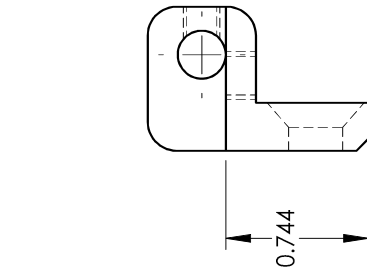
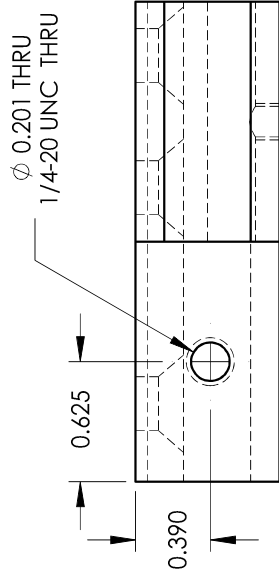
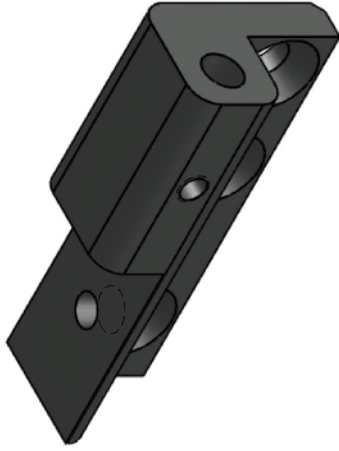
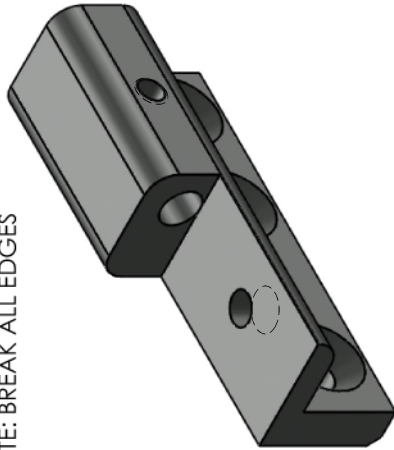

UNLESS OTHERWISE NOTED OR DEPICTED  
ALL DIMENSIONS ARE OUTSIDE IN INCHES  
ALL SURFACES ARE CONSIDERED CLASS "D"

REFER TO ENG-009 AND ENG-010  
FOR SURFACE FINISH CRITERIA

TOLERANCES:  
DIMENSIONS ± 0.005  
ANGLES ± 0.005  
REFERENCE DIMENSIONS ± 0.001



WOLF STEEL<sup>TM</sup>  
NAC

Product of  
WOLF STEEL  
CORPORATION

TITLE: HINGE, LOWER C/W DOOR STOP (REPL W330-0086)

DRAWING: W330-0095

MATERIAL: CRS

DRAWN BY: R.BARARI

FINISH: BLACK OXIDE

SCALE: 1:1

REVISION: ~

SHEET 1 OF 1

CHECKED BY: CLIFF

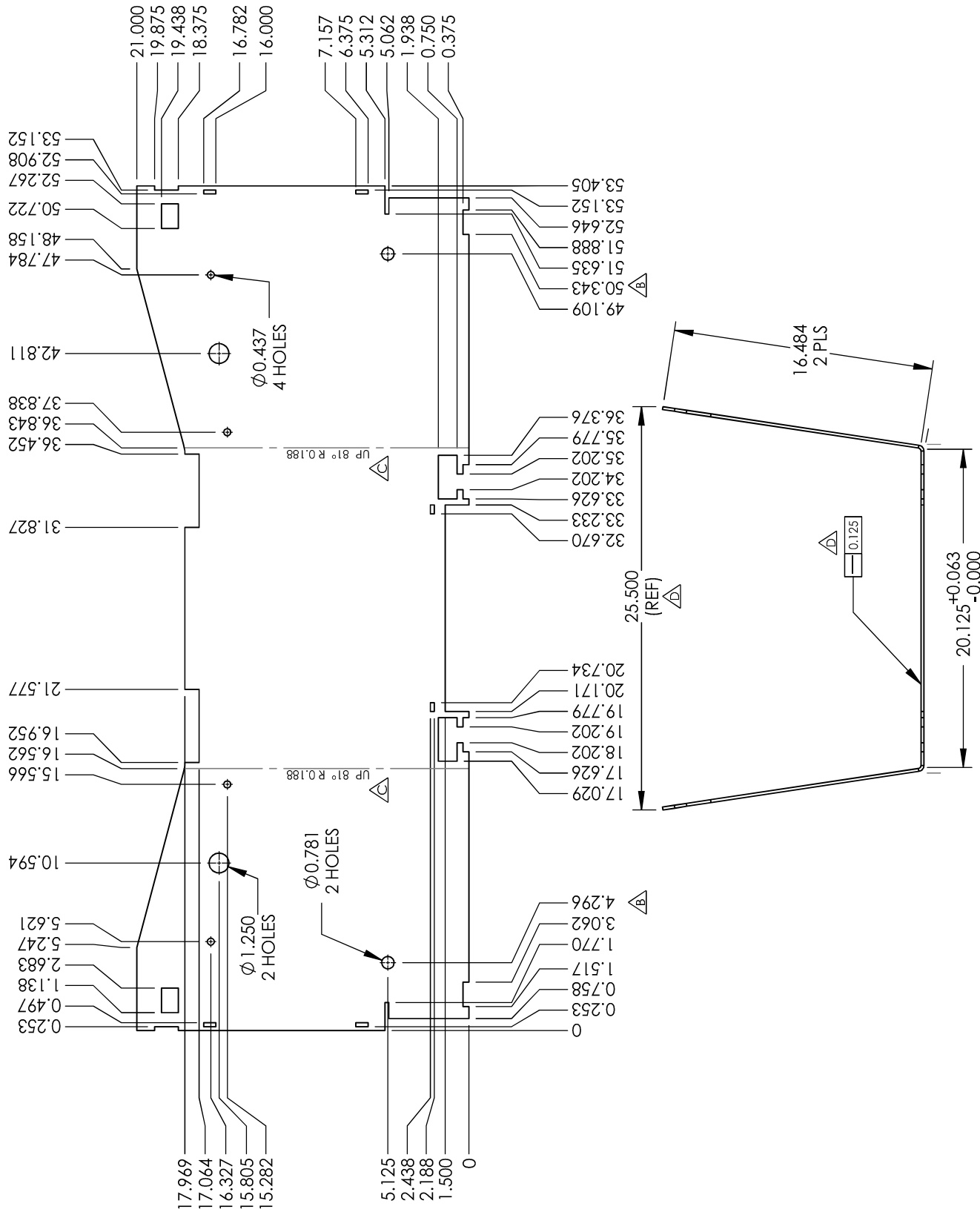

<p>UNLESS OTHERWISE NOTED OR DEPICTED ALL DIMENSIONS ARE OUTSIDE IN INCHES. ALL SURFACES ARE CONSIDERED CLASS "D" REFER TO ENG-009 AND ENG-010 FOR SURFACE FINISH CRITERIA</p> <p>TOLERANCES: FORMED PARTS ±0.031 REFERENCE DIMENSIONS ±0.063 BLANKED PARTS ±0.010 ANGLES ±2°</p>	<p>TITLE: <b>HOUSING, FIREBOX</b></p>	<p>MODEL: <b>W350-0603</b></p>	<p>EPI3 DRAWING: <b>W350-0603</b></p>
	<p>MATERIAL: 3/16 HR P&amp;O</p>	<p>THICKNESS: 0.188</p>	<p>DRAWN BY: <b>A.RIGDEN</b></p>
<p>FINISH:</p>	<p>REVISION: <b>D</b> MM/DD/YY: <b>7/8/2016</b> (AGR) ADD DIMS</p>	<p>SCALE: 1:9</p>	<p>SHEET 1 OF 1</p>
<p>98/7715 AGR</p>	<p><b>WOLF STEEL</b> NAC NAC STEEL LTD. AUSTIN, TEXAS</p>	<p>CHECKED BY: <b>R.TJART</b></p>	<p>6/13/2012</p>



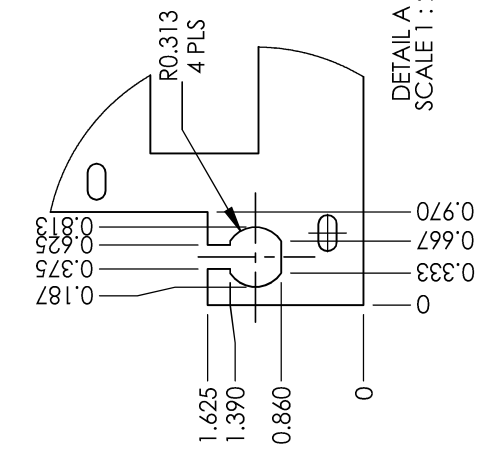
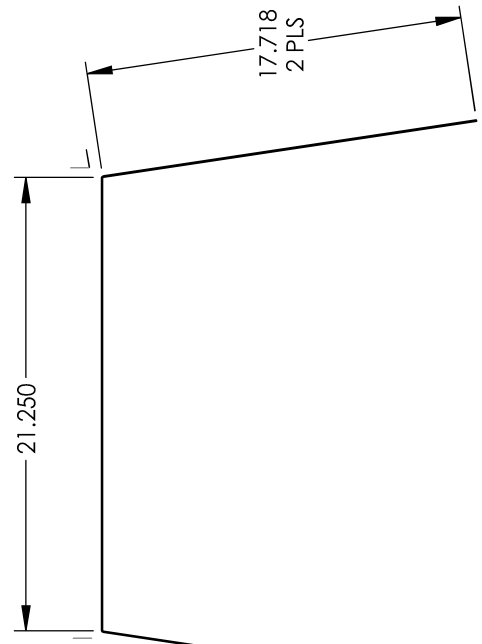
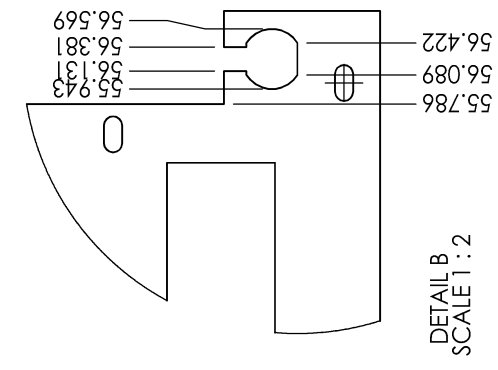
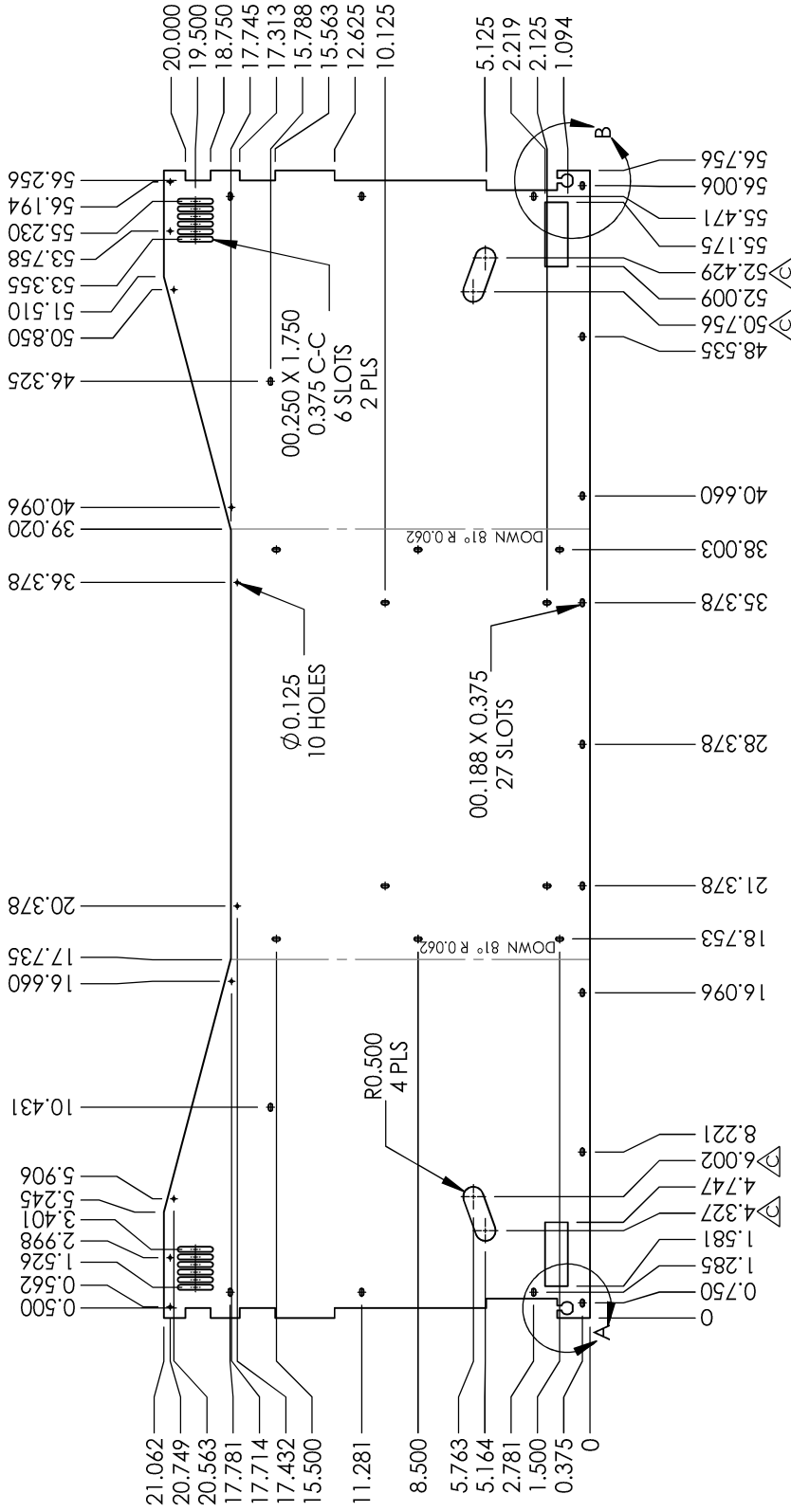

UNLESS OTHERWISE NOTED OR DEPICTED, ALL DIMENSIONS ARE REFERENCED TO CLASS 'D' ALL SURFACES ARE CONSIDERED CLASS 'D' REFER TO ENG-009 AND ENG-010 FOR SURFACE FINISH CRITERIA TOLERANCES: FORMED PARTS: ±0.031 REFERENCE DIMENSIONS ±0.063 BLANKED PARTS: ±0.010 ANGLES	TITLE:	<b>HOUSING, OUTER SHELL</b>	MODEL:	EPI3	DRAWING:	<b>W350-0604</b>	
	MATERIAL:	20 GA ALUMINIZED	THICKNESS:	0.039	DRAWN BY:	<b>A.RIGDEN</b>	
FINISH:		WEIGHT:	11.548 LBS	SCALE:	1:9	SHEET 1 OF 1	
REVISION:	<b>C</b>	DATE:	<b>5/24/2013</b>	APPROVED:	(AGR) MODIFY DIMS	CHECKED BY:	R.TJART



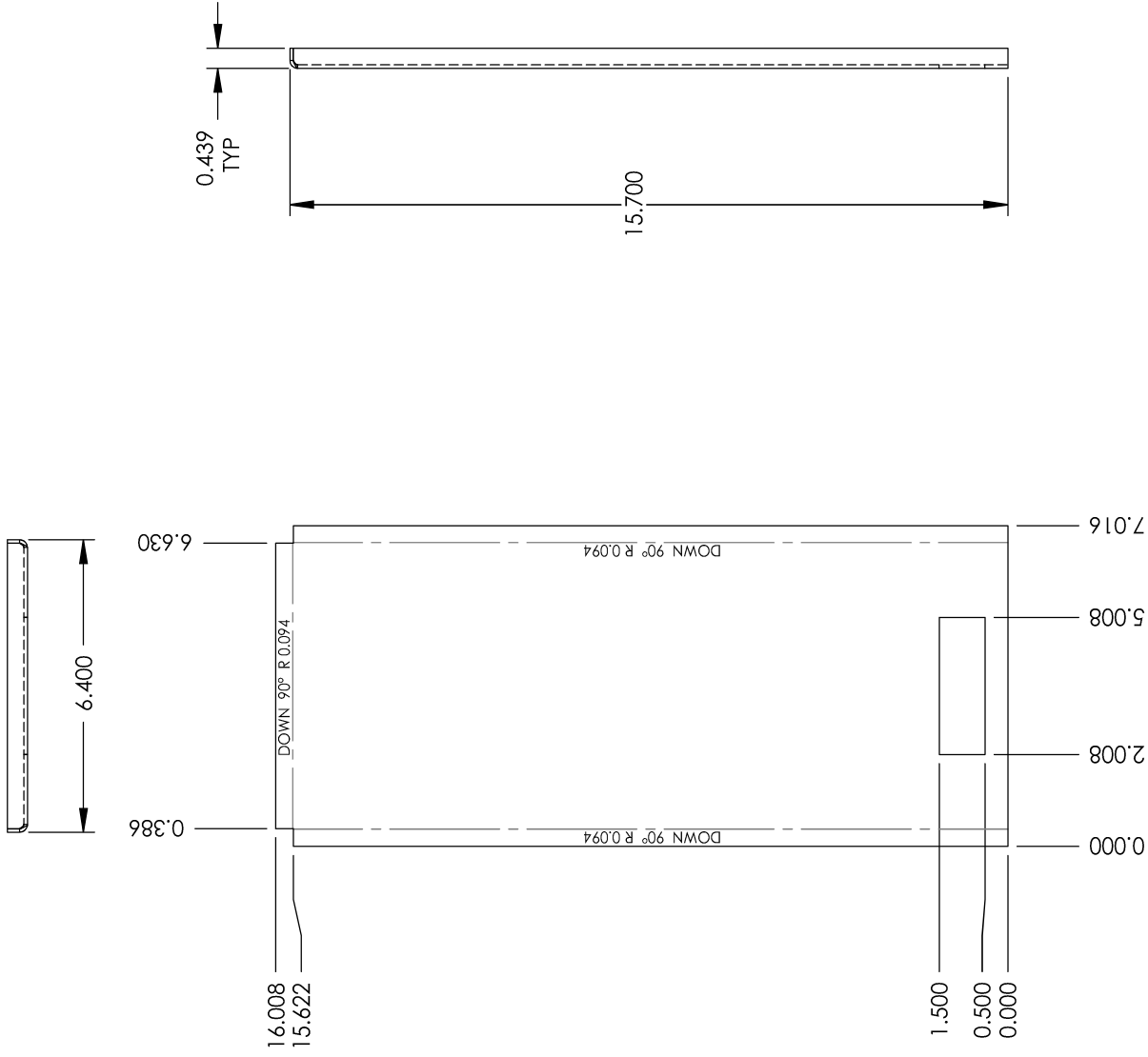

UNLESS OTHERWISE NOTED OR DEPICTED ALL DIMENSIONS ARE OUTSIDE IN INCHES ALL SURFACES ARE CONSIDERED CLASS "D" REFER TO ENG-009 FOR SURFACE FINISH CRITERIA TOLERANCES: FORMED PARTS ±0.031 REFERENCE DIMENSIONS ±0.063 BLANKED PARTS ±0.010 ANGLES ±2°	TITLE: HOUSING, S/A VERTICAL	MODEL: EPI3-1	DRAWING: W350-0930
	MATERIAL: 14 GA HR P&O	THICKNESS: 2.303 LBS	ISSUE DATE: 0.075
FINISH:	PROJECT LEAD: P HODGES	SCALE: 1:4	SHEET 1 OF 1
REVISION: P02	REV DATE: 03/22/19	REV NOTE:	CHECKED BY: UNRELEASED

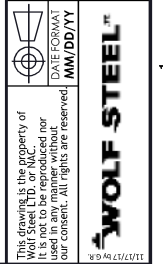

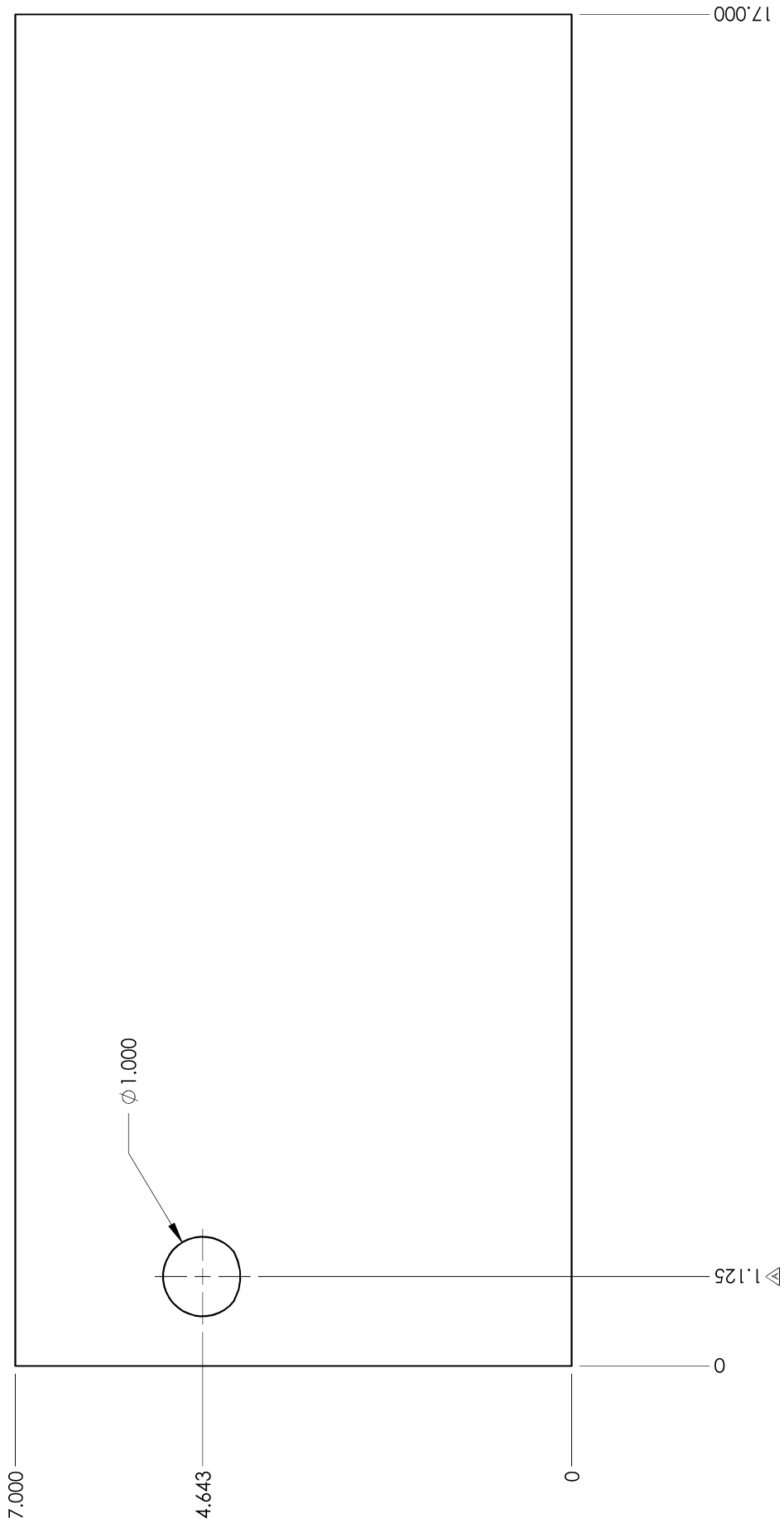

<p><b>UNLESS OTHERWISE NOTED OR DEPICTED</b>          ALL DIMENSIONS ARE OUTSIDE IN INCHES          ALL SURFACES ARE CONSIDERED CLASS 10</p>		<p><b>TOLERANCES:</b>          DIMENSIONS ±0.003"          REFERENCE DIMENSIONS ±0.125"          ANGLES ±2°</p>		<p><b>TITLE:</b> INSULATION, BLOWER HOUSING</p>	<p><b>MODEL:</b> EP13</p>	<p><b>DRAWING:</b> W361-0182</p>
<p><b>MATERIAL:</b> 1/2" CERAMIC FIBRE BLANKET</p>		<p><b>SCALE:</b> 1:2</p>		<p><b>MATERIAL:</b> 1/2" CERAMIC FIBRE BLANKET</p>	<p><b>SCALE:</b> 1:2</p>	<p><b>DRAWN BY:</b> A.RIGDEN</p>
<p><b>FINISH:</b></p>		<p><b>REVISION:</b> A</p>		<p><b>FINISH:</b></p>	<p><b>REVISION:</b> A</p>	<p><b>CHECKED BY:</b> R.TJART</p>
<p><b>DATE:</b> 7/24/2012</p>		<p><b>DESCRIPTION:</b> (AGR) ADD DIM</p>		<p><b>DATE:</b> 7/4/2012</p>	<p><b>SHEET:</b> SHEET 1 OF 1</p>	<p><b>DATE:</b> 7/4/2012</p>

01.09.12 AR

The drawing is the property of Wolf Steel LTD. or NAC. It is to be used for the project and not to be reproduced without our consent. All rights are reserved.

**WOLF STEEL**<sup>TM</sup>

**NAC**

Product Line in  
 A-400 L-400  
 C-400 H-400

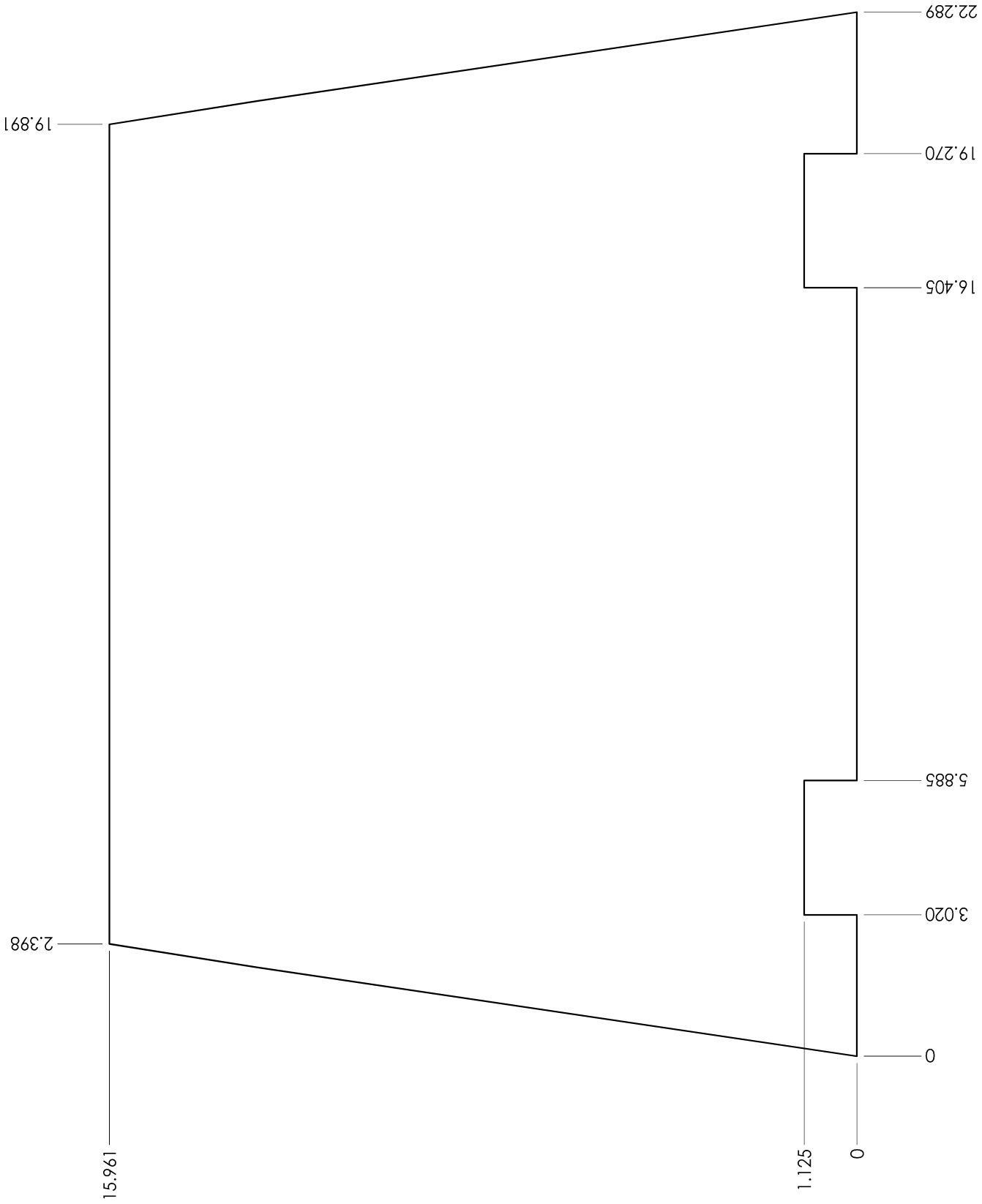

<p><b>UNLESS OTHERWISE NOTED OR DEPICTED</b>          ALL DIMENSIONS ARE OUTSIDE IN INCHES          ALL SURFACES ARE CONSIDERED CLASS 10<sup>1</sup></p> <p><b>TOLERANCES:</b>          DIMENSIONS ±0.003"          REFERENCE DIMENSIONS ±0.125"          ANGLES ±2°</p>		<p><b>TITLE:</b> INSULATION, FIREBOX BASE</p> <p><b>MATERIAL:</b> 1/8" CERAMIC FIBRE PAPER (2150°F)</p> <p><b>FINISH:</b></p> <p><b>REVISION:</b> 2</p>	<p><b>MODEL:</b> EP13</p> <p><b>SCALE:</b> 1:3</p> <p><b>SHEET 1 OF 1</b></p>	<p><b>DRAWING:</b> W361-0189</p> <p><b>DRAWN BY:</b> A.RIGDEN</p> <p><b>MM/DD/YYYY:</b> 2/8/2013</p> <p><b>CHECKED BY:</b> R.TJART</p>
--	--	---	---	--

This drawing is the property of Wolf Steel LTD. or NAC. It is not to be used, copied, or reproduced without our consent. All rights are reserved.

**WOLF STEEL<sup>TM</sup>**  
**NAC** Manufactured in Canada

02.20.13 AR

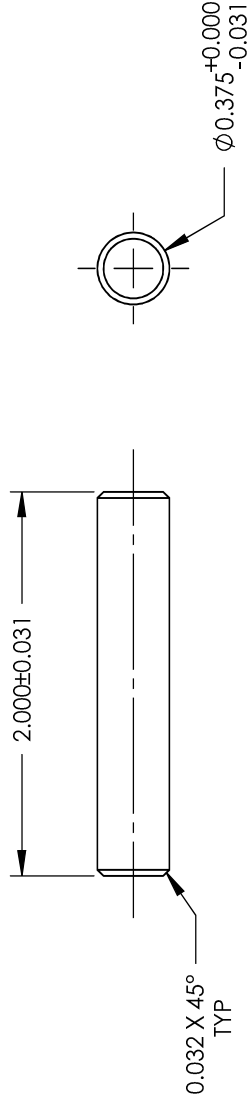

This drawing is the property of Wolf Steel Ltd., or NAC. It is to be used for the manufacture of the product shown here only. All rights are reserved.

UNLESS OTHERWISE NOTED OR DEPICTED  
ALL DIMENSIONS ARE OUTSIDE IN INCHES

TOLERANCES:  
DIMENSIONS ±0.062"  
REFERENCE DIMENSIONS ±0.125"  
ANGLES ±2°

TITLE: **PIN, HINGE**

MATERIAL: 0.375Ø DRWN CRS WIRE

FINISH:

REVISION: **D** 9/20/2010 (M.A.) MODELLED IN SW

DRAWING: **W485-0010**

DRAWN BY: **RICH**

MM/DD/YYYY: **7/10/1996**

CHECKED BY: **JFK**

MODEL: **GDS50**

0.062 LBS

SCALE: 1:1 SHEET 1 OF 1

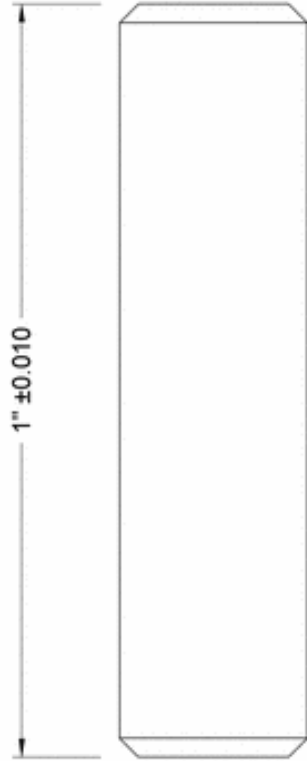
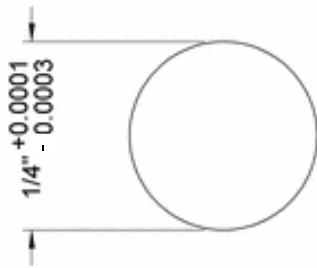

NOTE: Alloy Steel

**Reference Only**

WOLF STEEL

DIMS: INCHES/MM

TITLE: PIN, DOWEL 1/4" x 1"

DWG#: W485-0045

REV:

DATE: 07.09.12 RICH

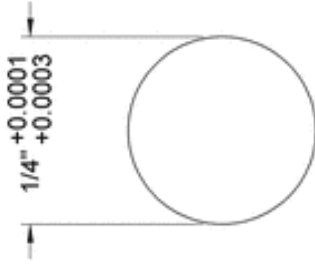

NOTE: Alloy Steel

**Reference Only**

WOLF STEEL

TITLE: PIN, DOWEL 1/4" x 3/4"

DWG #: W485-0052

REV:

DATE: 12.06.12\_RT

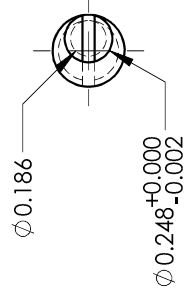
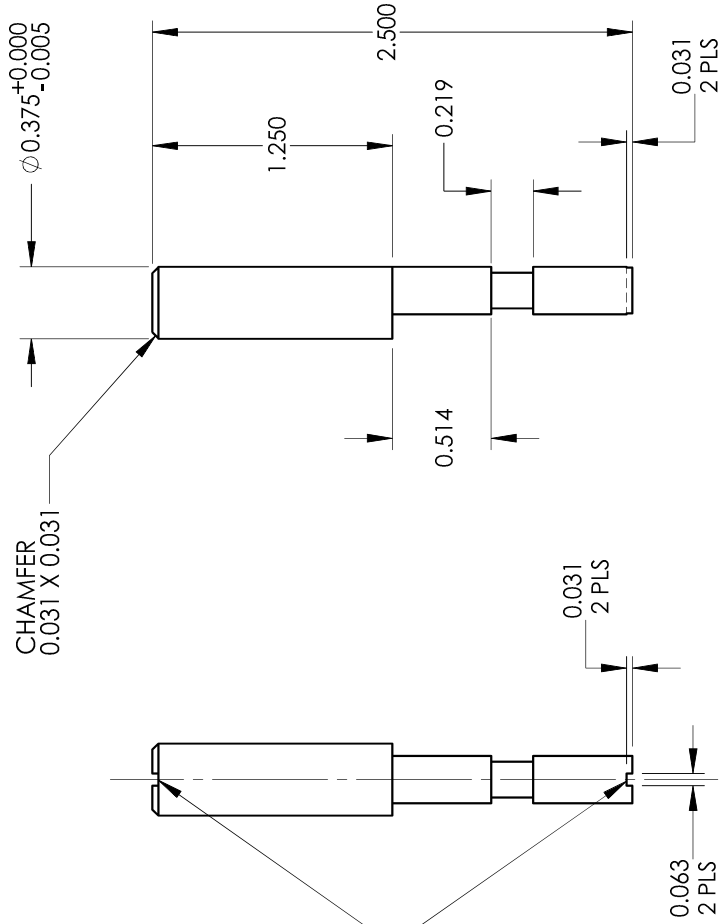
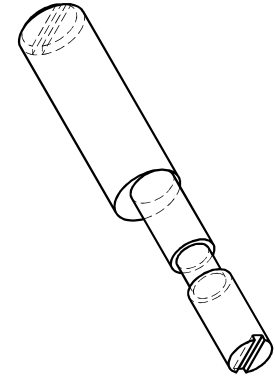

NOTE: BOTH ENDS  
MUST HAVE SLOT

The drawing is the property of Wolf Steel Ltd. or NAC. It is to be used only for the specific order for which it was prepared. All rights are reserved.

**WOLF STEEL™**  
**NAC** Manufactured in Australia

UNLESS OTHERWISE NOTED OR DEPICTED  
ALL DIMENSIONS ARE OUTSIDE IN INCHES  
ALL SURFACES ARE CONSIDERED CLASS "B"

TOLERANCES:  
DIMENSIONS ±0.005"  
ANGLES ±1°

TITLE:	PIN, ADJUSTABLE CAM HINGE	MODEL:	EP13	DRAWING:	W485-0053
MATERIAL:	CRS		0.054 LBS	DRAWN BY:	A.RIGDEN
FINISH:	BLACK OXIDE		SHEET 1 OF 1	MM/DD/YYYY:	6/18/2013
REVISION:	~			CHECKED BY:	R.TJART



LASER CHECKED

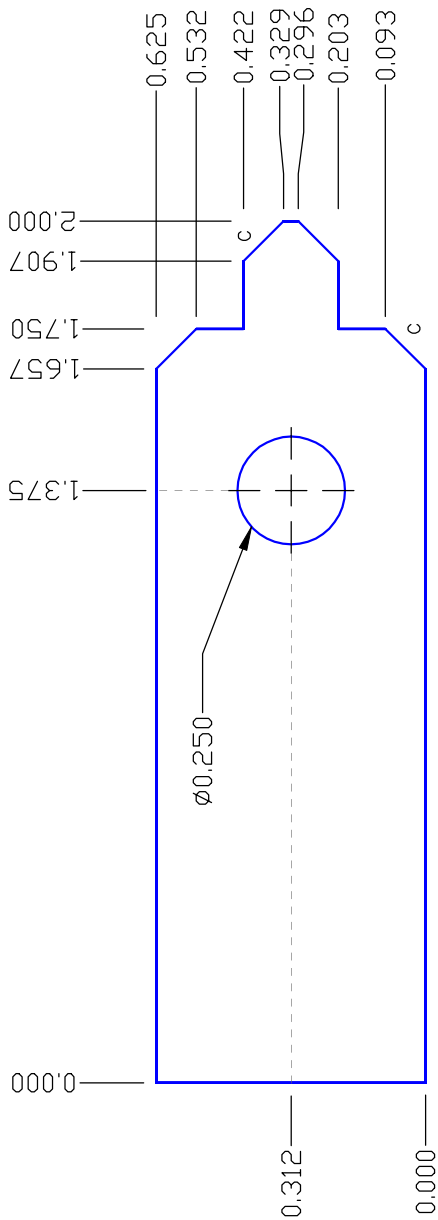

WOLF STEEL LTD.

TITLE: AIR TUBE RETAINER

MATERIAL: 14 GA ST. ST. P 0.074x0.625x2.000

REVISION: C:01.10.05||CHAMFER & UPDATE DWG# D:01.11.05||EDIT MAT'L DESCRIPTION

NZ26

DRAWING #: W500-0141 c

DATE: 08.25.99

CHECKED BY: JFK

TOLERANCES: UNLESS OTHERWISE NOTED,  
FORMED PARTS  $\pm 0.031$   
BLANKED PARTS  $\pm 0.005$   
REFERENCE DIMENSIONS  $\pm 0.063$   
ANGLES  $\pm 2^\circ$

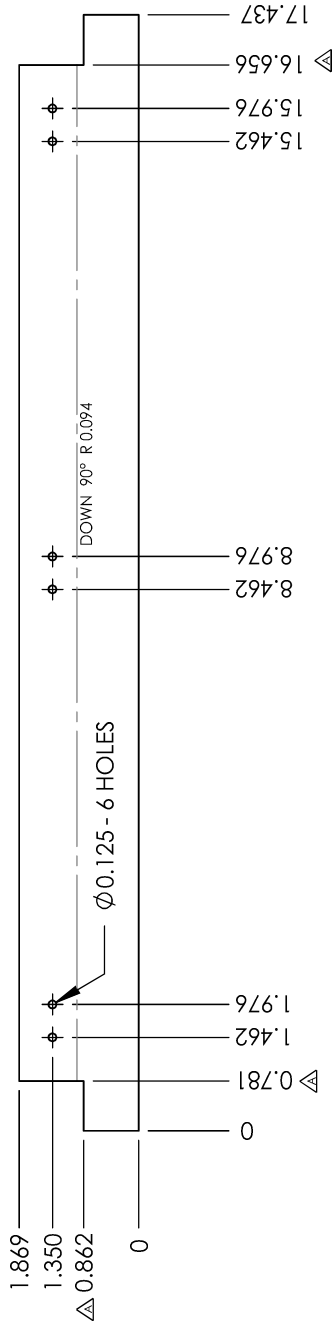
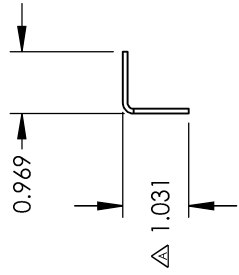

<p>UNLESS OTHERWISE NOTED OR DEPICTED ALL DIMENSIONS ARE OUTSIDE IN INCHES</p> <p>TOLERANCES: WHERE APPLICABLE, FLAT IS SHOWN FINISHED SIDE UP</p> <p>FORMED PARTS ±0.031" BLANKED PARTS ±0.010" REFERENCE DIMENSIONS ±0.063" ANGLES ±2°</p>	<p>TITLE: <b>RETAINER, OUTER SHELL (REAR)</b></p>	<p>MODEL: EP13</p>	<p>DRAWING: <b>W500-0575</b></p>
	<p>MATERIAL: 14 GA HR P&amp;O</p>	<p>THICKNESS: 0.075</p>	<p>DRAWN BY: <b>A.RIGDEN</b></p>
	<p>FINISH:</p>	<p>SCALE: 1:3</p>	<p>SHEET 1 OF 1</p>
	<p>REVISION: <b>A</b> 1/28/2013 (AGR) ADD MTL/ADD NOTCHES</p>	<p>0.654 LBS</p>	<p>CHECKED BY: R.TJART</p>



D

C

B

A

0.500  
2 PLS



14.254



3.125  
2.900

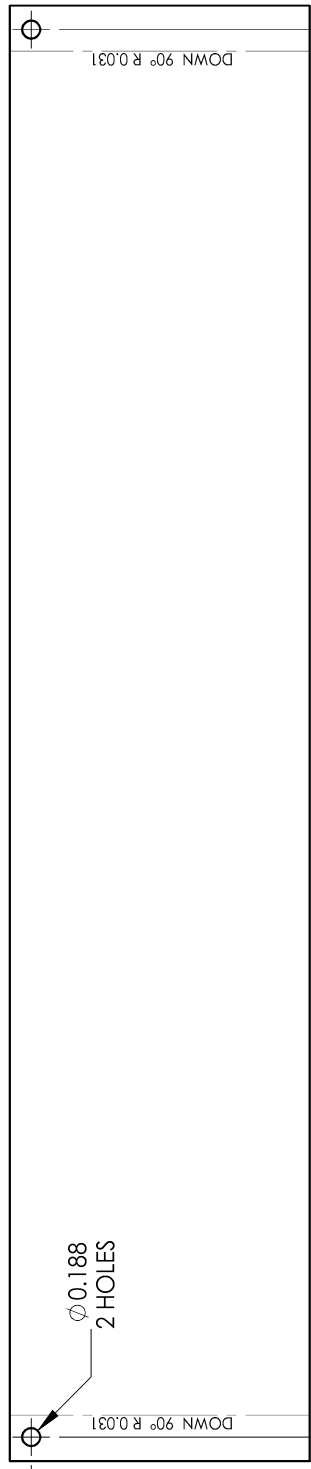

$\phi 0.188$   
2 HOLES

DOWN 90° R.0031

0.250

15.162  
14.912



This drawing is the property of  
Wolf Steel Ltd. or NCC.  
It is to be used only for  
the project and not  
used in any manner without  
our consent. All rights are reserved.



UNLESS OTHERWISE NOTED OR DEPICTED  
ALL DIMENSIONS ARE OUTSIDE IN INCHES  
ALL SURFACES ARE CONSIDERED CLASS "D"  
REFER TO ENG-009 AND ENG-010  
FOR SURFACE FINISH CRITERIA

TOLERANCES:  
FORMED PARTS ±0.031 REFERENCE DIMENSIONS ±0.063  
BLANKED PARTS ±0.010 ANGLES ±2

TITLE: **PLATE, RATING**

MATERIAL: 24 GA GALVANNEAL

FINISH:

MODEL:

THICKNESS:

SCALE: 1:2

EPI3

0.027

SHEET 1 OF 1

DRAWING: **W500-0638**

ISSUE DATE: **6/13/2012**

DRAWN BY: **MS**

CHECKED BY: **CL**

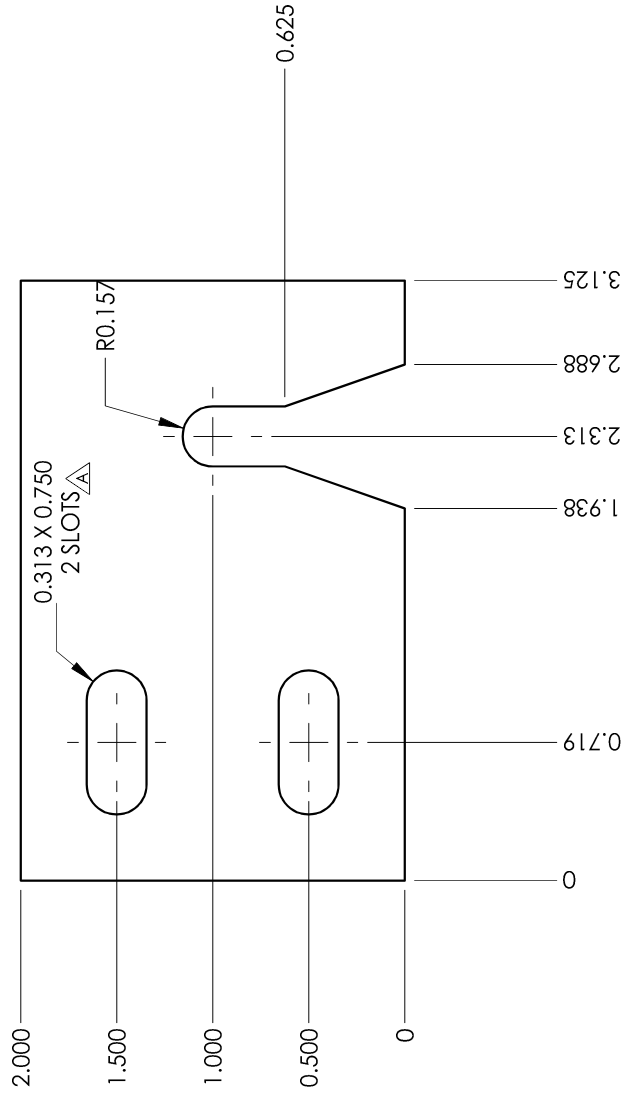

UNLESS OTHERWISE NOTED OR DEPICTED  
 ALL DIMENSIONS ARE OUTSIDE IN INCHES  
 UNLESS OTHERWISE SPECIFIED  
 WHERE APPLICABLE, FLAT IS SHOWN FINISHED SIDE UP

**TOLERANCES:**  
 FORMED PARTS ±0.031"  
 BURNED PARTS ±0.063"  
 SURFACE DIMENSIONS ±.2°  
 ANGLES



**WOLF STEEL**<sup>TM</sup>  
**NAC**  
 NORTH AMERICAN  
 CASTING COMPANY

TITLE:	RETAINER, CASTING	MODEL:	EPI3T	DRAWING:	W500-0641
MATERIAL:	14 GA HR P&O	THICKNESS:	0.075	DRAWN BY:	A.RIGDEN
FINISH:		SCALE:	1:1	MM/DD/YYYY:	6/13/2012
REVISION:	A	(SDE) REVISED SLOT AND LENGTH AS PER ECN WSL817	SHEET 1 OF 1	CHECKED BY:	R.TJART

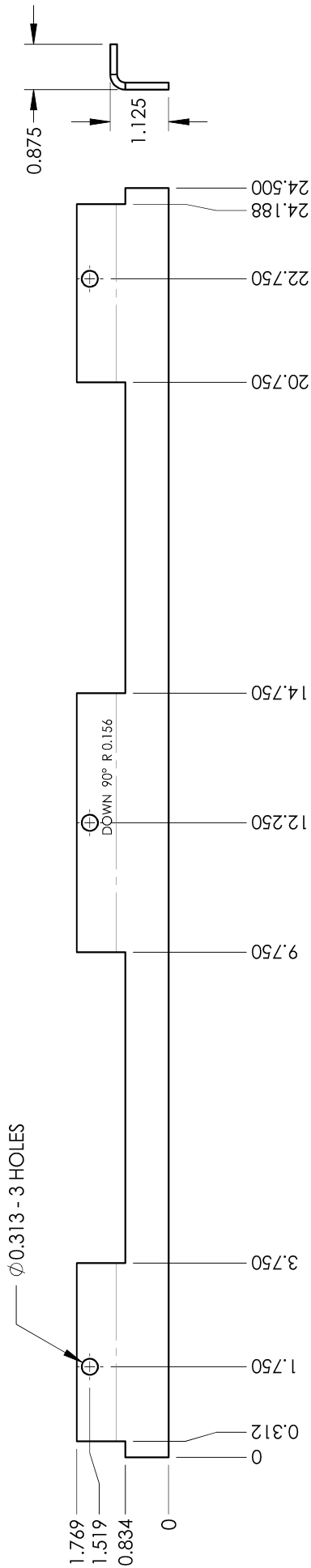
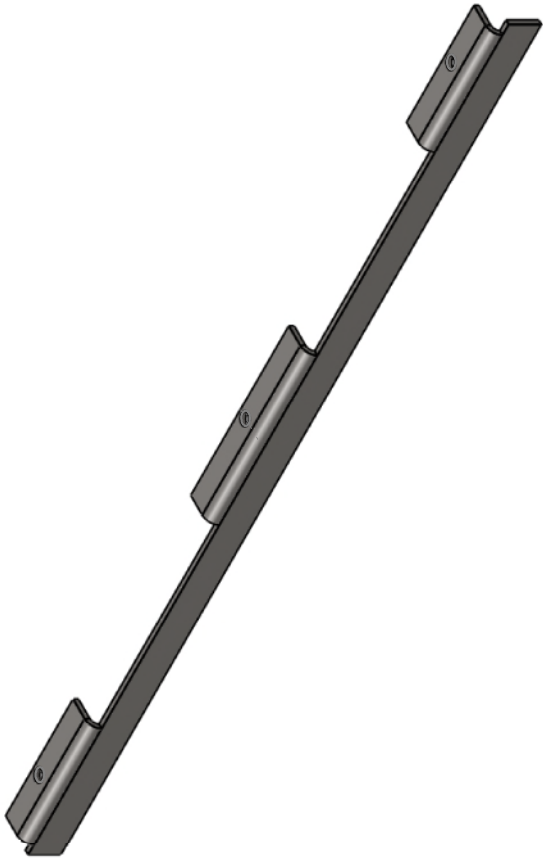
NOTES:  
NOTE 1 MUST BE BURR FREE

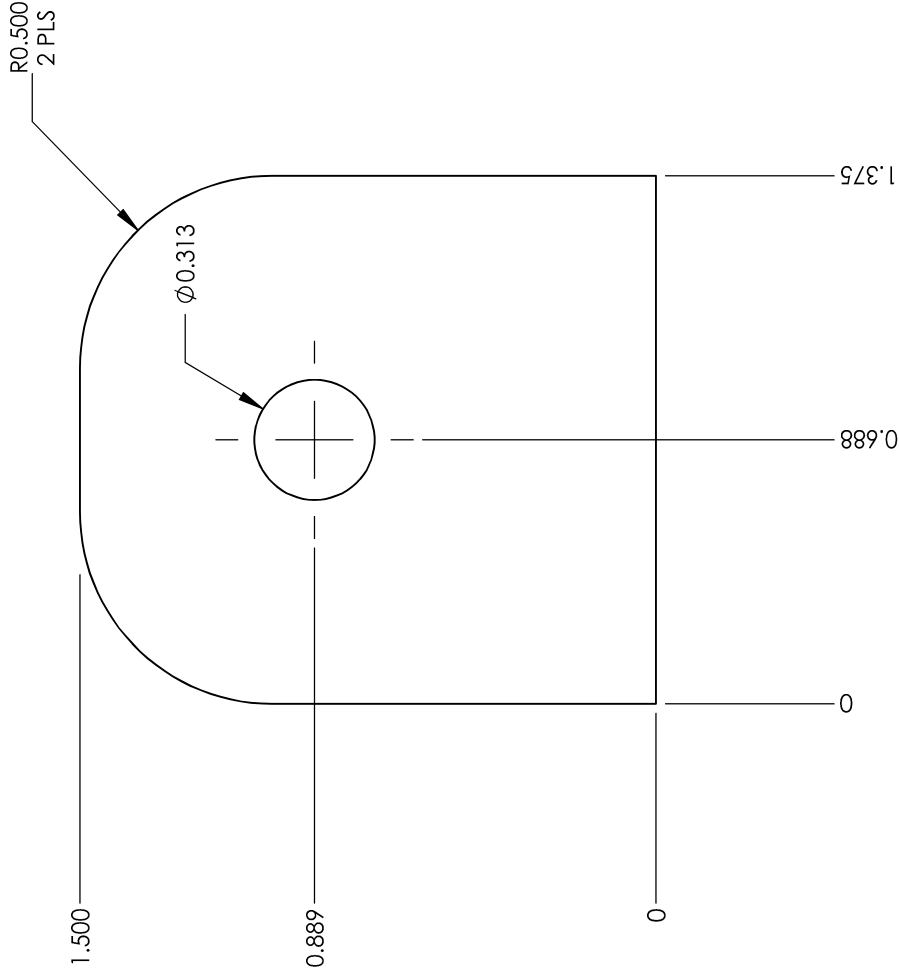

This drawing is the property of Wolf Steel Ltd. or NCC. It is not to be used in any manner without our consent. All rights are reserved.		UNLESS OTHERWISE NOTED OR DEPICTED ALL DIMENSIONS ARE OUTSIDE IN INCHES ALL SURFACES ARE CONSIDERED CLASS "D"		TITLE: <b>PLATE, SMOKE SHELF</b>		MODEL: <b>EPI3-1</b>		DRAWING: <b>W500-0647</b>	
		REFER TO ENG-009 FOR SURFACE FINISH CRITERIA		MATERIAL: <b>10 GA HR P&amp;O</b>		THICKNESS: <b>0.135</b>		ISSUE DATE: <b>6/13/2012</b>	
TOLERANCES: FORMED PARTS $\pm 0.031$ REFERENCE DIMENSIONS $\pm 0.063$ BEANED PARTS $\pm 0.010$ ANGLES $\pm 2$		FINISH:		PROJECT LEAD: <b>P HODGES</b>		SCALE: <b>1:3</b>		SHEET <b>1 OF 1</b>	
DATE FOR WAT MM/DD/YY		REVISION: <b>P00</b>		REV DATE: <b>6/19/2018</b>		REV NOTE:		DRAWN BY: <b>UNRELEASED</b>	
1		2		3		4		5	



UNLESS OTHERWISE NOTED OR DEPICTED  
 ALL DIMENSIONS ARE OUTSIDE IN INCHES  
 UNLESS OTHERWISE SPECIFIED  
 WHERE APPLICABLE, FLAT IS SHOWN FINISHED SIDE UP

**TOLERANCES:**  
 FORMED PARTS ±0.031"  
 BEVELLED PARTS ±0.063"  
 SURFACE DIMENSIONS ±0.063"  
 ANGLES ±2°

The drawing is the property of Wolf Steel LTD., or NAC. It is to be kept confidential and not to be reproduced without our consent. All rights are reserved.

**WOLF STEEL**<sup>TM</sup>  
**NAC**  
 NORTH AMERICAN  
 COLLECTIVE

10/9.12 AR

TITLE:	RETAINER, FLUE COLLAR	MODEL:	EP13	DRAWING:	W500-0691
MATERIAL:	3/16 HR P&O	THICKNESS:	0.188	DRAWN BY:	A.RIGDEN
FINISH:		SCALE:	2:1	MM/DD/YYYY:	6/13/2012
REVISION:	-			CHECKED BY:	R.TJART

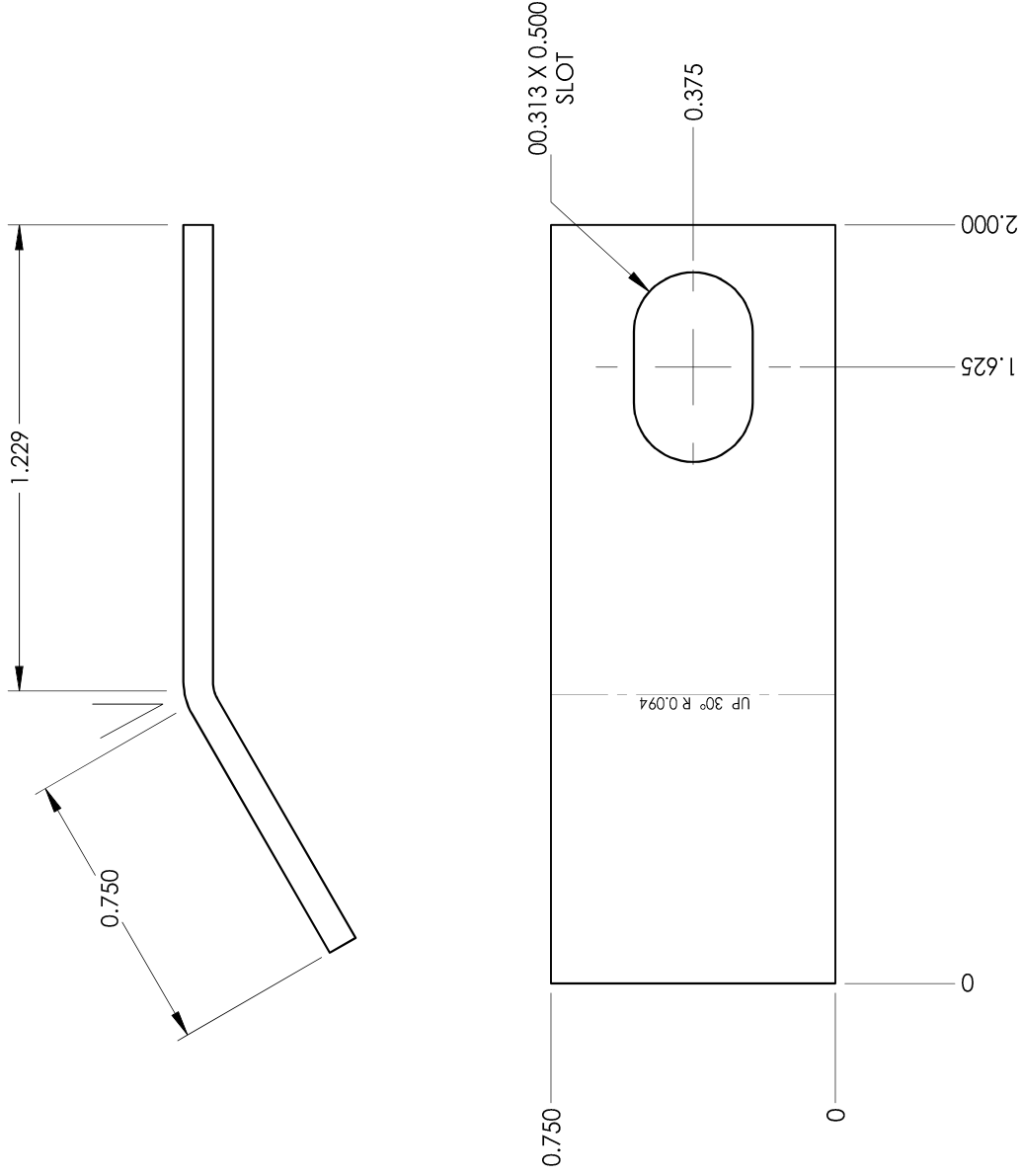

UNLESS OTHERWISE NOTED OR DEPICTED  
 ALL DIMENSIONS ARE OUTSIDE IN INCHES  
 UNLESS OTHERWISE SPECIFIED  
 WHERE APPLICABLE FLAT IS SHOWN FINISHED SIDE UP

**TOLERANCES:**  
 FORMED PARTS ±0.031"  
 BEAVED PARTS ±0.031"  
 SURFACE DIMENSIONS ±.2°  
 ANGLES

The drawing is the property of Wolf Steel LTD., or NAC. It is to be used only for the project and order number shown hereon. Without our consent, all rights are reserved.

**WOLF STEEL**<sup>TM</sup>  
**NAC**  
 NAC Steel Ltd.  
 10000 12th Ave. S.E.  
 Calgary, Alberta T2C 1L9

TITLE:	RETAINER, BRICK (FRONT)	MODEL:	EP13	DRAWING:	W500-0693
MATERIAL:	14 GA SS 430-2B	THICKNESS:	0.031 LBS	DRAWN BY:	A.RIGDEN
FINISH:		SCALE:	2:1	SHEET 1 OF 1	MM/DD/YYYY: 7/6/2012
REVISION:	-	CHECKED BY:			R.TJART

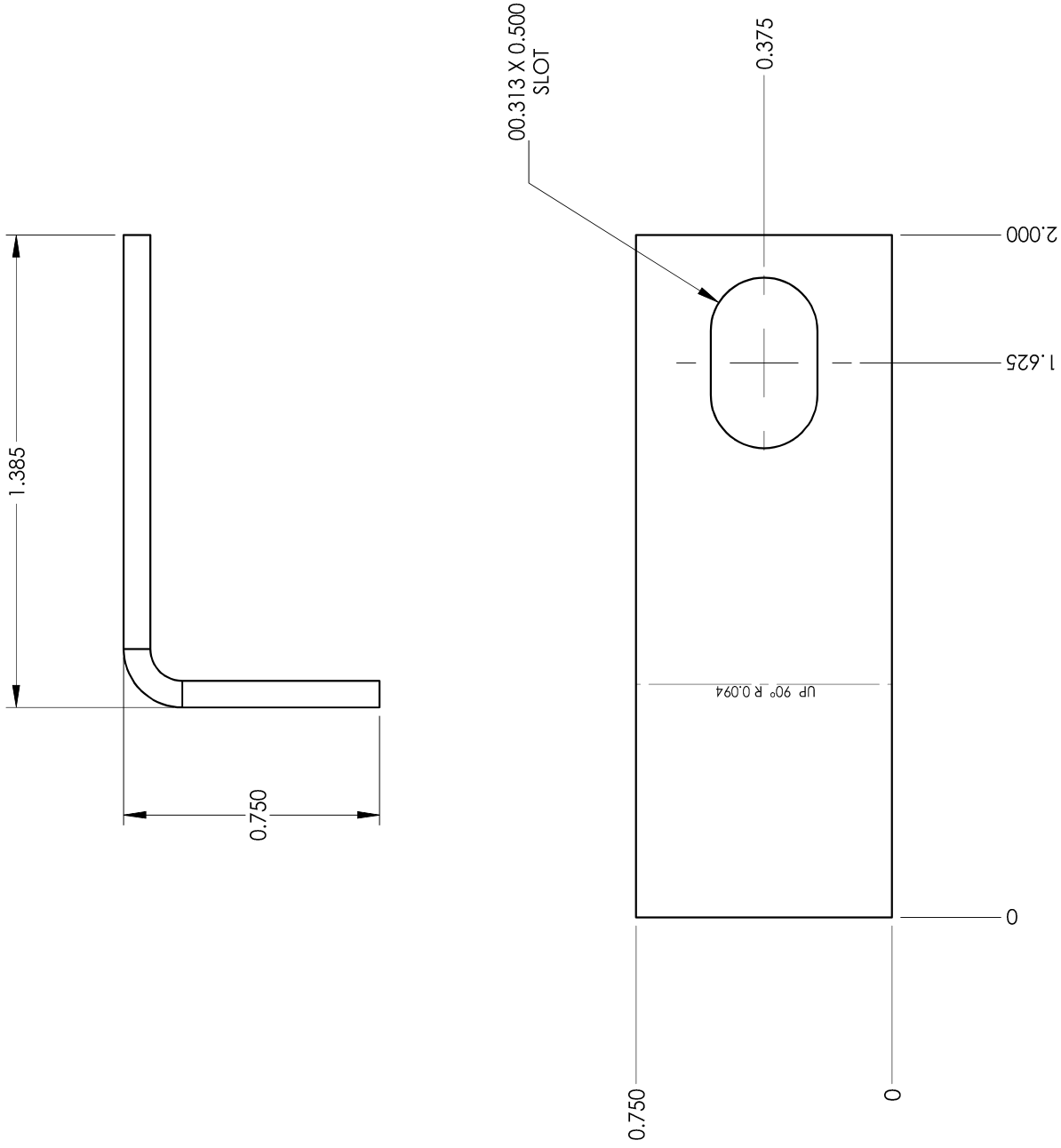

<p>UNLESS OTHERWISE NOTED OR DEPICTED ALL DIMENSIONS ARE OUTSIDE IN INCHES UNLESS OTHERWISE SPECIFIED WHERE APPLICABLE, FLAT IS SHOWN FINISHED SIDE UP</p> <p>TOLERANCES: FORMED PARTS ±0.031" BLANKED PARTS ±0.003" SURFACE DIMENSIONS ±0.003" ANGLES ±2°</p>	TITLE:	RETAINER, BRICK (REAR)	MODEL:	EP13	DRAWING:	W500-0694
	MATERIAL:	14 GA SS 430-2B	THICKNESS:	0.078	DRAWN BY:	A.RIGDEN
	FINISH:		SCALE:	2:1	SHEET 1 OF 1	7/6/2012
	REVISION:	-	CHECKED BY:			R.TJART

This drawing is the property of Wolf Steel LTD., or NAC. It is to be used only for the project and quantity specified. All rights are reserved.

**WOLF STEEL**<sup>TM</sup>  
**NAC**

Manufactured in  
Australia  
CORPORATION

01/09/12 AR



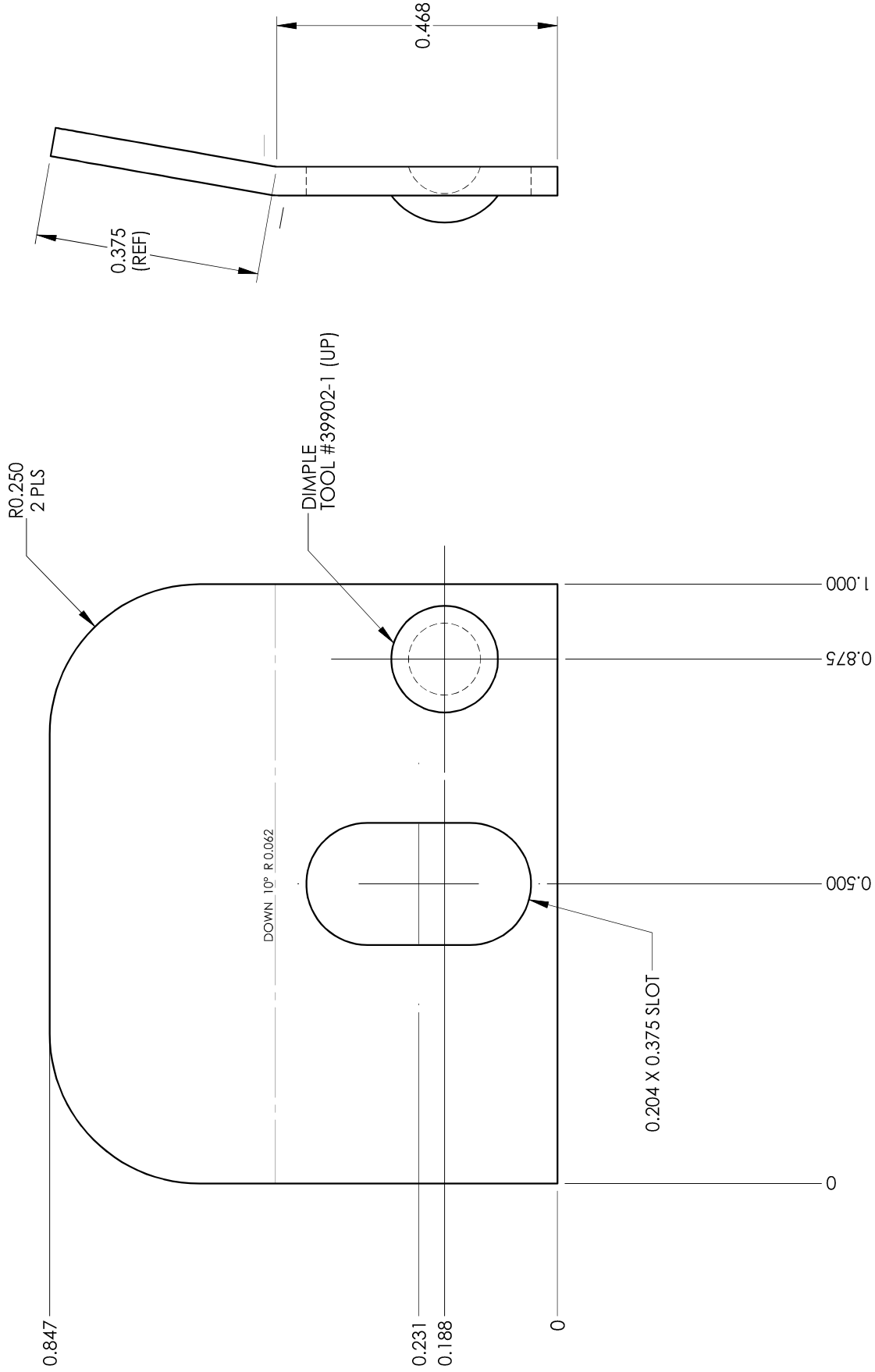

UNLESS OTHERWISE NOTED OR DEPICTED  
ALL DIMENSIONS ARE OUTSIDE IN INCHES  
UNLESS OTHERWISE NOTED  
WHERE APPLICABLE FLAT IS SHOWN FINISHED SIDE UP

TOLERANCES:  
FORMED PARTS  
±0.031"  
BLANK PARTS  
±0.009"  
SURFACE DIMENSIONS  
±2°  
ANGLES



This drawing is the property of Wolf Steel LTD., or NAC.  
It is not to be reproduced, stored in a retrieval system,  
or transmitted in any form or by any means, electronic,  
mechanical, photocopying, recording, or by any information  
storage and retrieval system, without our consent. All rights are reserved.

**WOLF STEEL**<sup>TM</sup>  
**NAC**  
NORTH AMERICAN  
CORPORATION

TITLE:	RETAINER, GLASS	MODEL:	S4	DRAWING:	W500-0709
MATERIAL:	18 GA CRS	THICKNESS:	0.048	DRAWN BY:	J.DUCHESNE
FINISH:		SCALE:	4:1	SHEET 1 OF 1	11/6/2012
REVISION:	A	1/30/2013	(AGR) ADD DIMPLE	CHECKED BY:	R.TJART
		0.010 LBS			

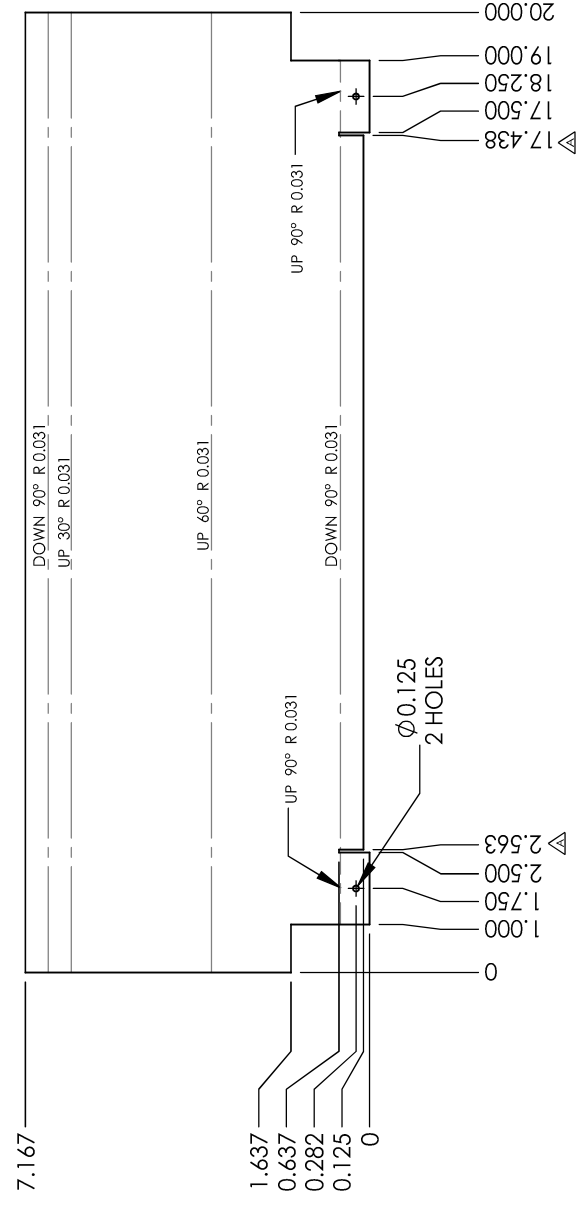
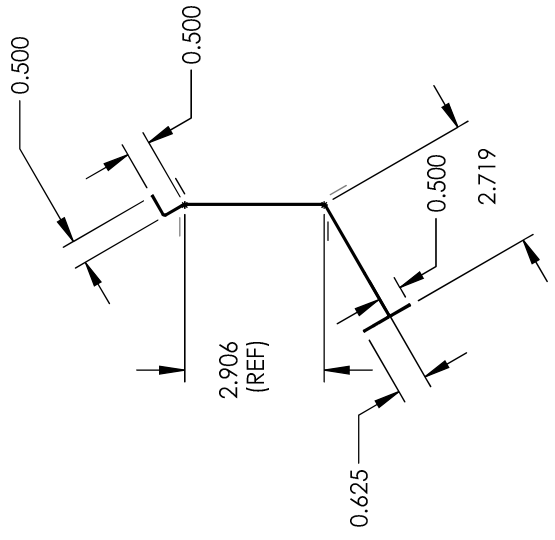

<p>UNLESS OTHERWISE NOTED OR DEPICTED, ALL DIMENSIONS ARE REFERENCED TO THE CLASS 'D' SURFACES ARE CONSIDERED CLASS 'D' REFER TO ENG-009 AND ENG-010 FOR SURFACE FINISH CRITERIA</p> <p>TOLERANCES:                  FORMED PARTS: ±0.031 REFERENCE DIMENSIONS ±0.063                  BLANKED PARTS: ±0.010 ANGLES ±2</p>	<p>TITLE: SHEILD, HEAT (BLOWER)</p>	<p>MODEL: EP13</p>	<p>DRAWING: W585-0783</p>
	<p>MATERIAL: 24 GA GALVANNEAL</p>	<p>THICKNESS: 1.060 LBS</p>	<p>DRAWN BY: A.RIGDEN</p>
<p>FINISH:</p>	<p>REVISION: A</p>	<p>SCALE: 1:4</p>	<p>SHEET 1 OF 1</p>
<p>DATE: 3/28/2013</p>	<p>(AGR) MODIFY DIMS</p>	<p>DATE: 2/25/2013</p>	<p>DATE: 2/25/2013</p>



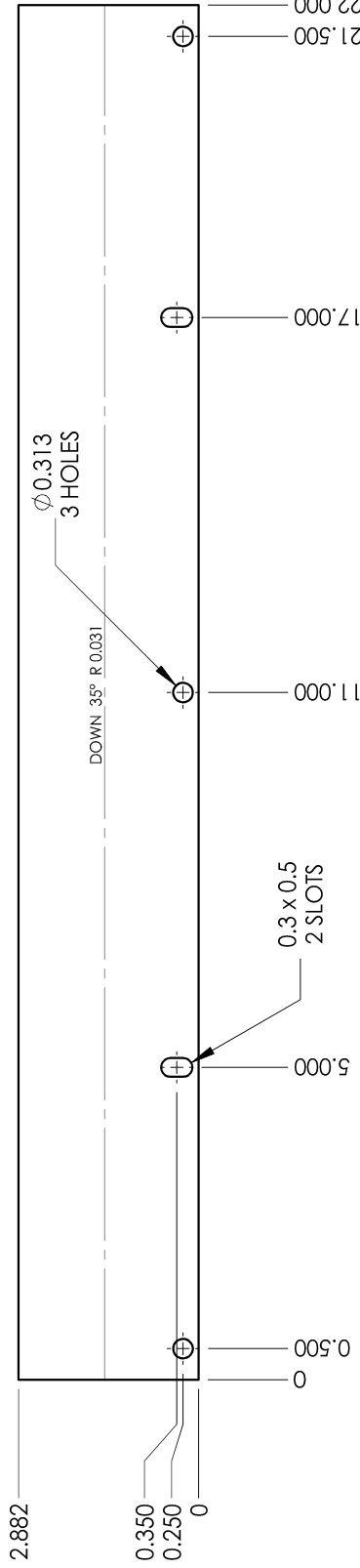
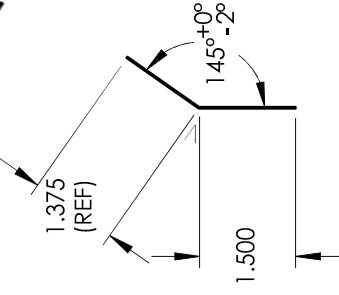
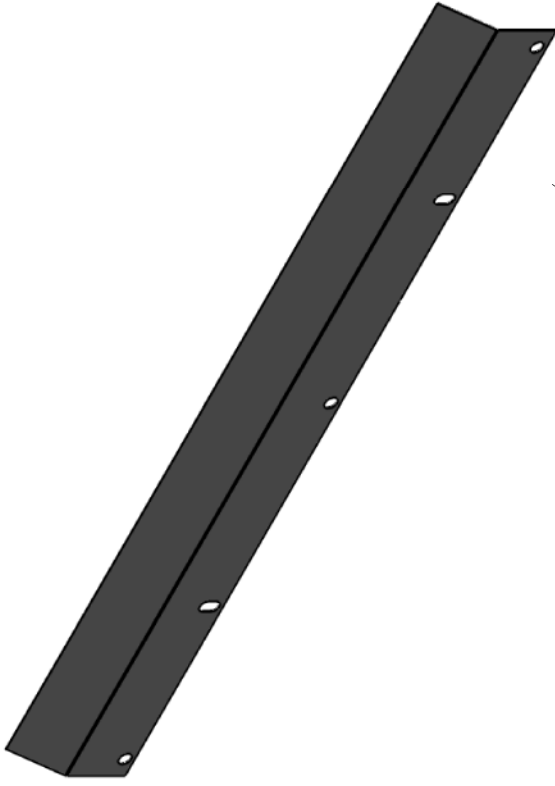

This drawing is the property of Wolf Steel Ltd. or NCC. It is not to be used in any manner without our consent. All rights are reserved.		TITLE: <b>SHIELD, AIRWASH</b>		MODEL: EPI3-1	DRAWING: <b>W585-0794</b>
		MATERIAL: 24 GA SS 304-2B		THICKNESS: 0.025	ISSUE DATE: <b>09/29/2009</b>
UNLESS OTHERWISE NOTED OR DEPICTED ALL DIMENSIONS ARE OUTSIDE IN INCHES ALL SURFACES ARE CONSIDERED CLASS "D" REFER TO ENG-009 FOR SURFACE FINISH CRITERIA		PROJECT LEAD: P HODGES		SCALE: 1:3	SHEET 1 OF 1
TOLERANCES: FORMED PARTS ±0.031 REFERENCE DIMENSIONS ±0.063 BEANED PARTS ±0.010 ANGLES ±2°		REVISION: <b>P00</b> REV DATE: <b>6/19/2018</b>		CHECKED BY: UNRELEASED	DRAWN BY: UNRELEASED



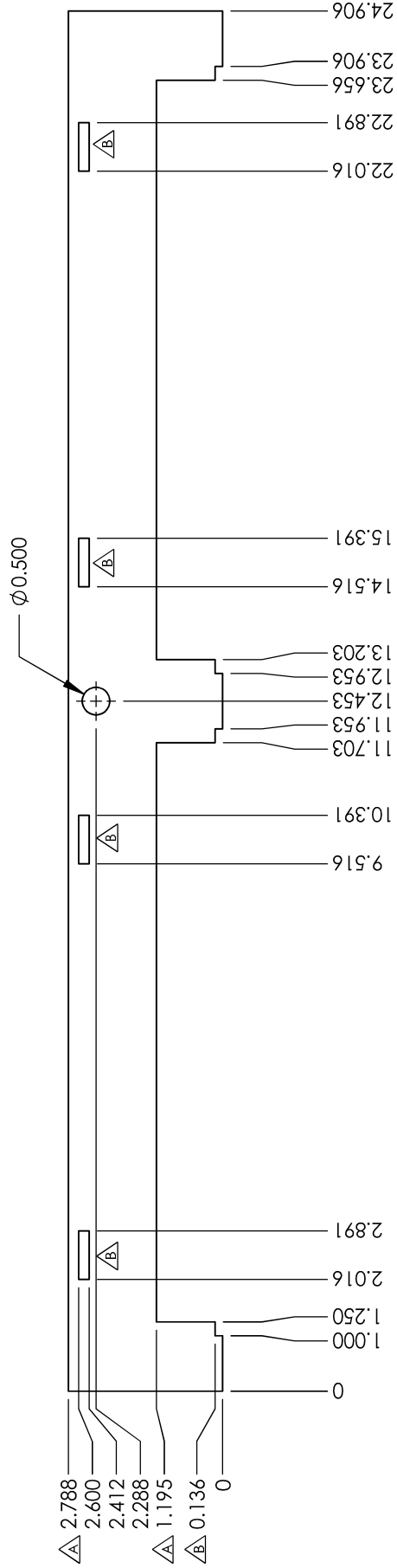

UNLESS OTHERWISE NOTED OR DEPICTED  
 ALL DIMENSIONS ARE OUTSIDE IN INCHES  
 UNLESS OTHERWISE NOTED  
 WHERE APPLICABLE FLAT IS SHOWN FINISHED SIDE UP

TOLERANCES:  
 FORMED PARTS ±0.031"  
 BURNED PARTS ±0.063"  
 SURFACE DIMENSIONS ±.2°  
 ANGLES



This drawing is the property of Wolf Steel LTD., or NAC.  
 It is to be used only for the project and order  
 number for which it was prepared. All rights are reserved.

**WOLF STEEL**<sup>TM</sup>  
**NAC**  
 MEMBER OF  
 A-COLD-STEEL  
 CORPORATION

TITLE:	<b>STIFFNER, FIREBOX TOP</b>	MODEL:	EP13	DRAWING:	<b>W655-0404</b>
MATERIAL:	3/16 HR P&O	THICKNESS:	0.188	DRAWN BY:	<b>A.RIGDEN</b>
FINISH:		SCALE:	1:3	SHEET 1 OF 1	<b>6/13/2012</b>
REVISION:	<b>B</b>	(AGR) ADD SLOTS/MODIFY DIM		CHECKED BY:	<b>R.TJART</b>
		WEIGHT:	2.303 LBS		

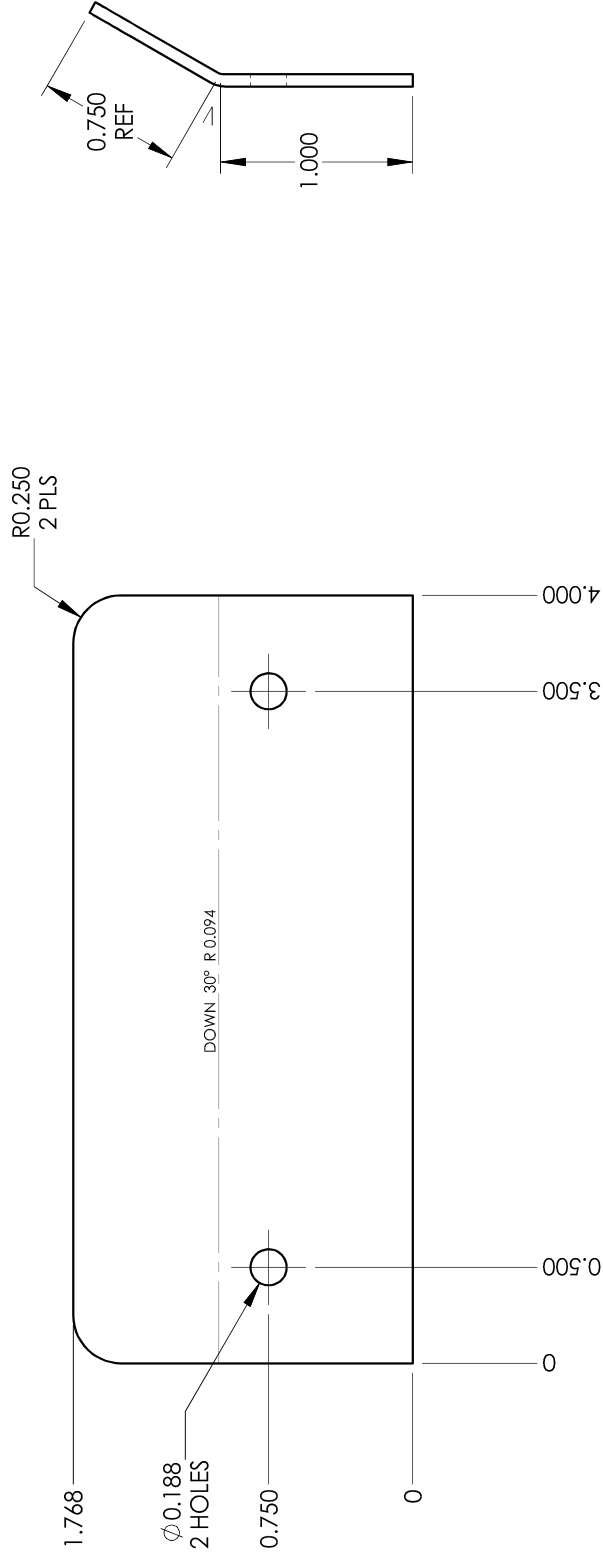

UNLESS OTHERWISE NOTED OR DEPICTED: ALL DIMENSIONS ARE TO BE HONORED TO 1/16" INCHES ALL SURFACES ARE CONSIDERED CLASS "D" REFER TO ENG-009 AND ENG-010 FOR SURFACE FINISH CRITERIA TOLERANCES: FORMED PARTS: ±0.031 REFERENCE DIMENSIONS ±0.063 BLANKED PARTS: ±0.010 ANGLES ±2	TITLE:	<b>SUPPORT, CASTING CENTRE</b>		MODEL:	EPI3T	DRAWING:	<b>W655-0469</b>
	MATERIAL:	16 GA	GALVANNEAL	THICKNESS:	0.063	DRAWN BY:	<b>A.RIGDEN</b>
	FINISH:			SCALE:	1:1	SHEET 1 OF 1	<b>3/6/2013</b>
	REVISION:	-		CHECKED BY:			<b>R.TJART</b>

This drawing is the property of Wolf Steel LTD. or NAC.  
 It is to be used only for the project and order number  
 without our consent. All rights are reserved.

**WOLF STEEL**<sup>TM</sup>  
**NAC**  
 NORTH AMERICAN  
 CASTING COMPANY

02.20.13 AR

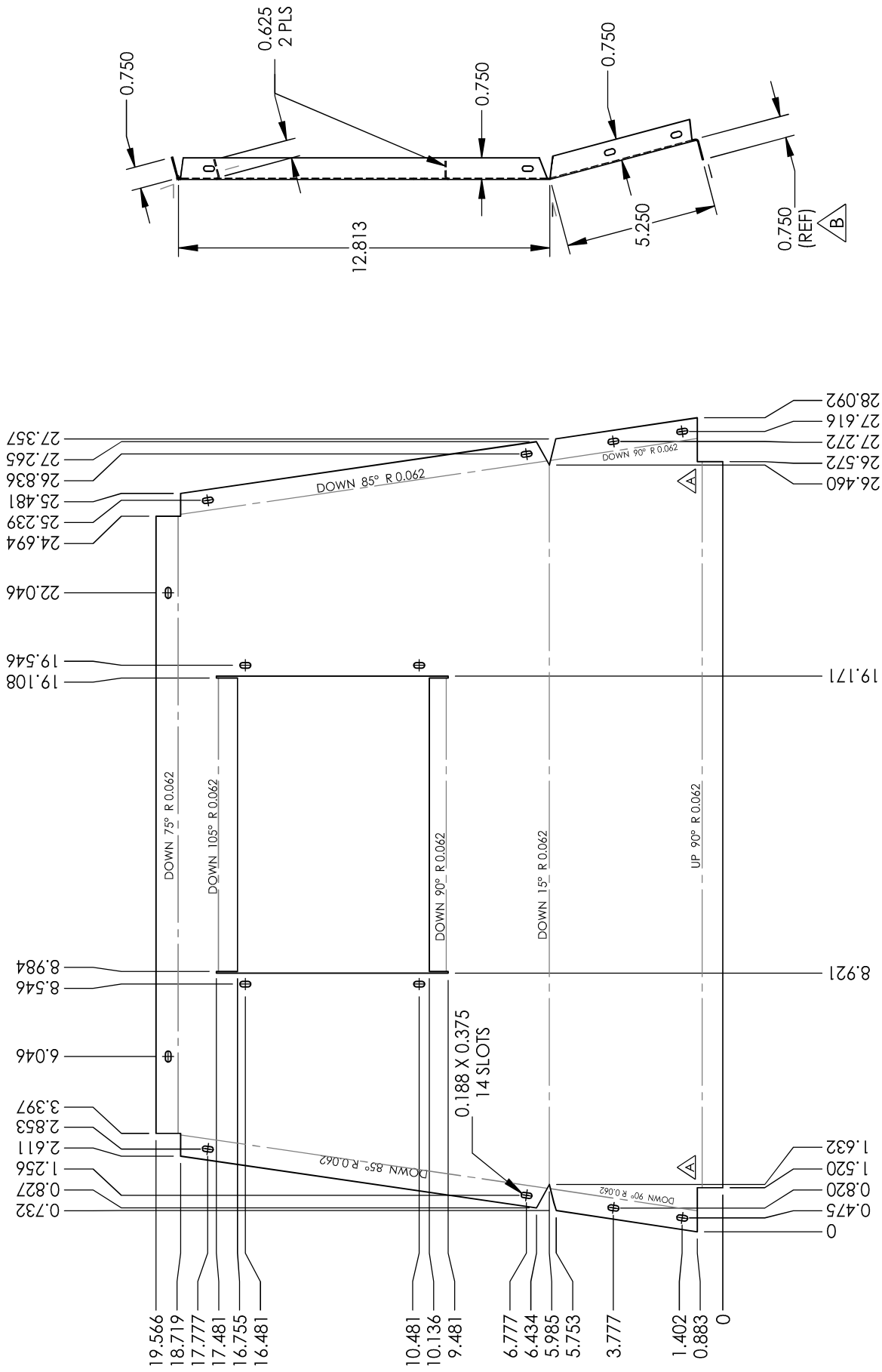

<p>UNLESS OTHERWISE NOTED OR DEPICTED ALL DIMENSIONS ARE OUTSIDE IN INCHES</p> <p>WHERE APPLICABLE, FLAT IS SHOWN FINISHED SIDE UP</p> <p>FORMED PARTS ±0.031" BLANKED PARTS ±0.010" REFERENCE DIMENSIONS ±0.063" ANGLES ±2°</p>	<p>TITLE: <b>TOP, OUTER SHELL</b></p>	<p>MODEL: EP13</p>	<p>DRAWING: <b>W705-0264</b></p>
	<p>MATERIAL: 20 GA GALVANNEAL</p>	<p>THICKNESS: 0.039</p>	<p>DRAWN BY: <b>A.RIGDEN</b></p>
<p>REVISION: <b>B</b></p>	<p>9/10/2013</p>	<p>SCALE: 1:5</p>	<p>SHEET 1 OF 1</p>
<p>(AGR) FIX DIM</p>	<p>4.711 LBS</p>	<p>CHECKED BY: <b>R.TJART</b></p>	<p>6/13/2012</p>



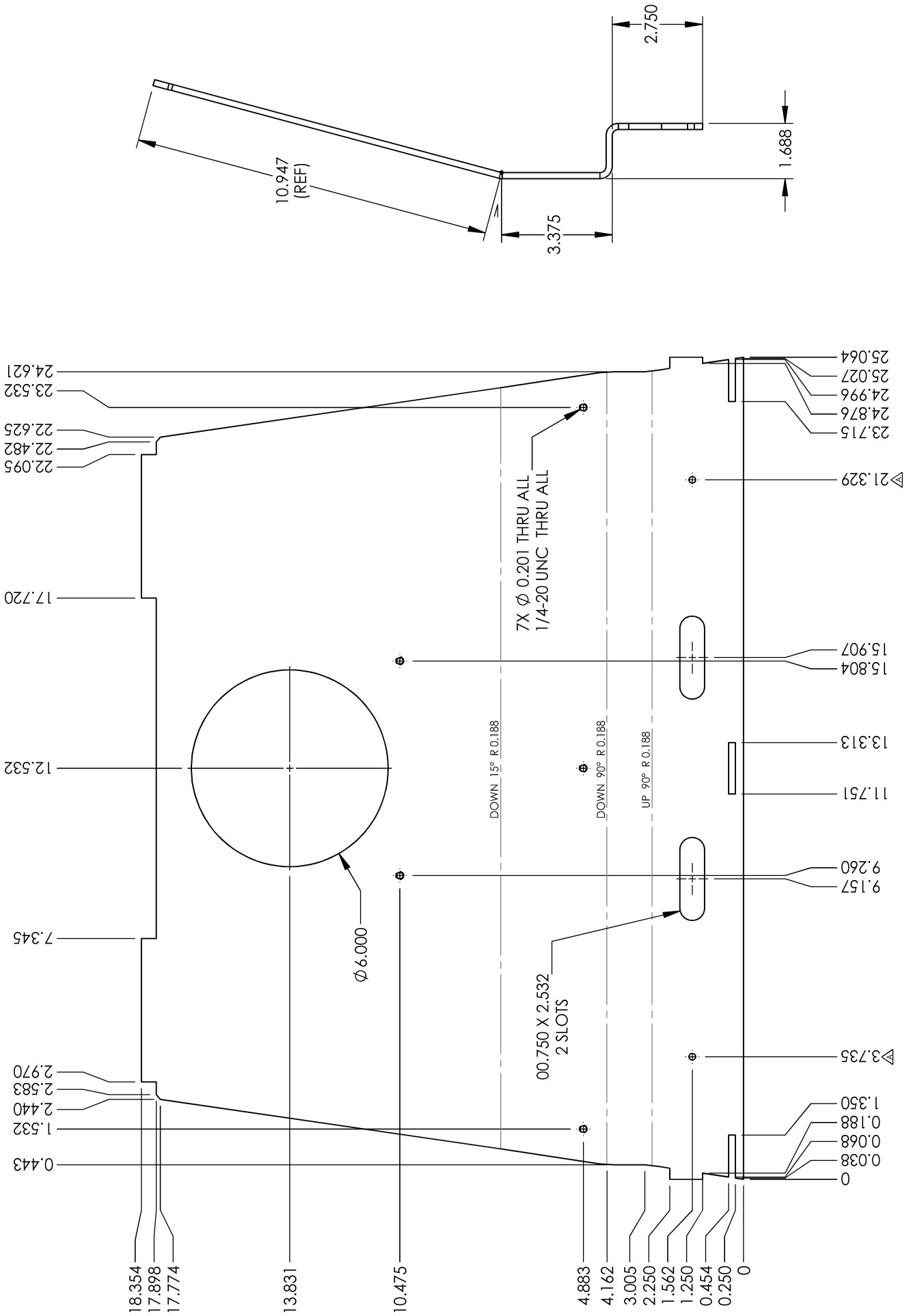

<p>UNLESS OTHERWISE NOTED OR DEPICTED ALL DIMENSIONS ARE OUTSIDE IN INCHES WHERE APPLICABLE FLAT IS SHOWN FINISHED SIDE UP</p>		<p>TOLERANCES: FORMED PARTS ±0.031" BLANKED PARTS ±0.005" SURFACE DIMENSIONS ±2° ANGLES</p>		<p>TITLE: <b>TOP, FIREBOX</b></p>	<p>MODEL: EPT3</p>	<p>DRAWING: <b>W705-0276</b></p>
<p>MATERIAL: 3/16 HR P&amp;O</p>		<p>20.016 LBS</p>	<p>THICKNESS: 0.188</p>	<p>DRAWN BY: <b>A.RIGDEN</b></p>	<p>CHECKED BY:</p>	
<p>FINISH:</p>		<p>SCALE: 1:4</p>	<p>SHEET 1 OF 1</p>	<p>MM/DD/YYYY: <b>6/13/2012</b></p>	<p>DATE:</p>	
<p>REVISION: <b>A</b></p>		<p><b>1/30/2013</b></p>	<p>(AGR) MOVE HOLES</p>	<p>DATE:</p>		





**NOTE: PART MUST BE FREE OF BURRS**

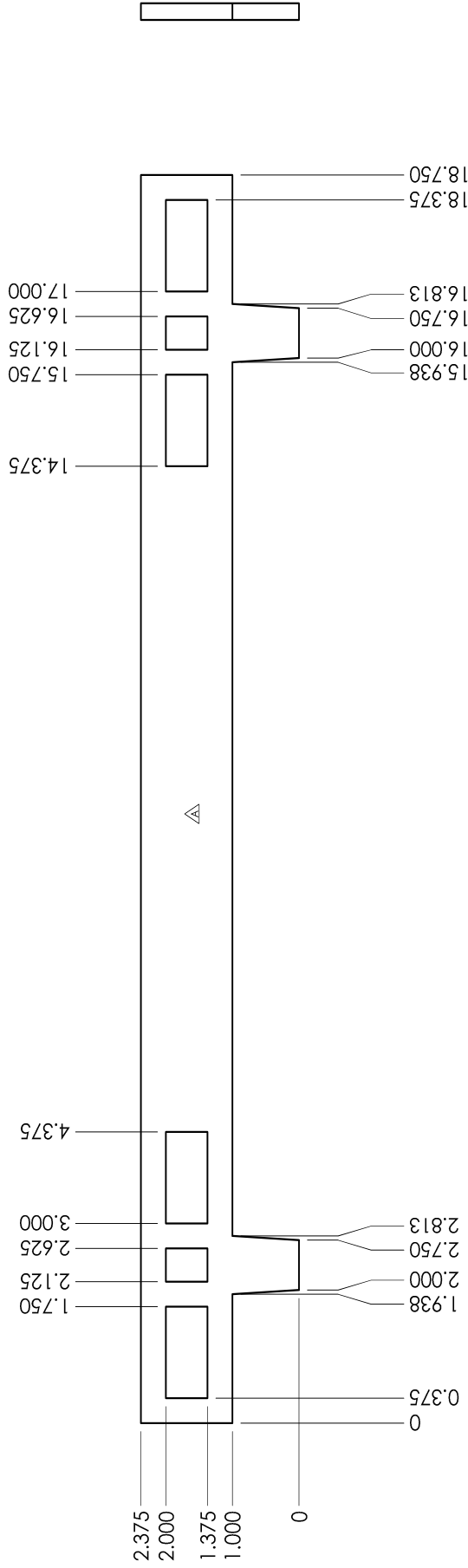

UNLESS OTHERWISE NOTED OR DEPICTED: ALL DIMENSIONS ARE TO BE HONORED TO 1/16" TOLERANCE. ALL SURFACES ARE CONSIDERED CLASS "D" REFER TO ENG-009 AND ENG-010 FOR SURFACE FINISH CRITERIA TOLERANCES: FORMED PARTS: ±0.031 REFERENCE DIMENSIONS ±0.063 BLANKED PARTS: ±0.010 ANGLES ±2	TITLE: <b>TRIM, LOG RETAINER</b>	MODEL: EP13	DRAWING: <b>W715-0916</b>
	MATERIAL: 1/4 HR P&O	THICKNESS: 1.645 LBS	DRAWN BY: <b>A.RIGDEN</b>
FINISH:	REVISION: <b>A</b>	SCALE: 1:2.5	SHEET 1 OF 1
(AGR) REMOVE CENTRE SLOT	2/25/2013	CHECKED BY:	R.TJART



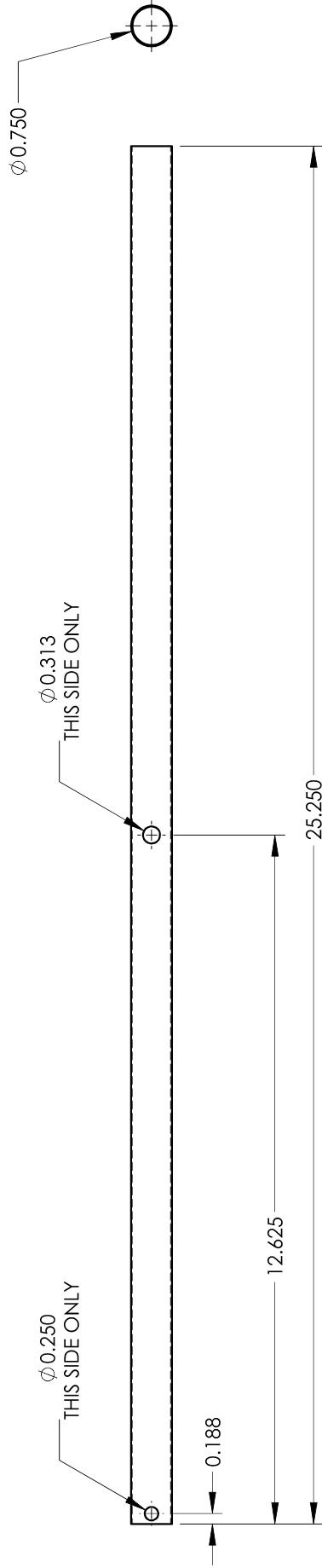

UNLESS OTHERWISE NOTED OR DEPICTED  
 ALL DIMENSIONS ARE OUTSIDE IN INCHES  
 UNLESS OTHERWISE SPECIFIED  
 WHERE APPLICABLE, FLAT IS SHOWN FINISHED SIDE UP

**TOLERANCES:**  
 FORMED PARTS ±0.031"  
 BEVELLED PARTS ±0.063"  
 SURFACE DIMENSIONS ±.2°  
 ANGLES

This drawing is the property of Wolf Steel Ltd., or NAC. It is to be used only for the project and for the quantity specified. All rights are reserved.

**WOLF STEEL**<sup>TM</sup>  
**NAC**  
 MEMBER OF THE  
 ACIPOLCO GROUP

TITLE:	<b>TUBE, PILOT</b>	MODEL:	EP13	DRAWING:	<b>W720-0165</b>
MATERIAL:	18 GA 430 ST. ST. - ZB FINISH	THICKNESS:	0.048	DRAWN BY:	<b>A.RIGDEN</b>
FINISH:		SCALE:	1:3	MM/DD/YYYY:	<b>6/13/2012</b>
REVISION:	-			SHEET 1 OF 1	CHECKED BY: <b>R.TJART</b>
		0.399 LBS			

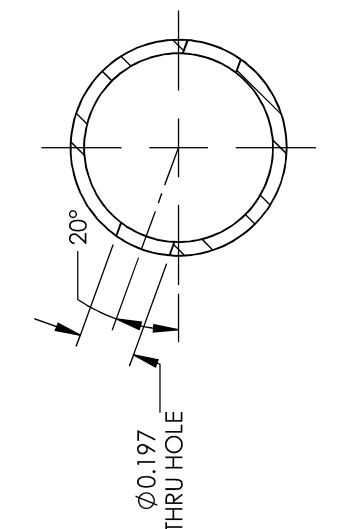
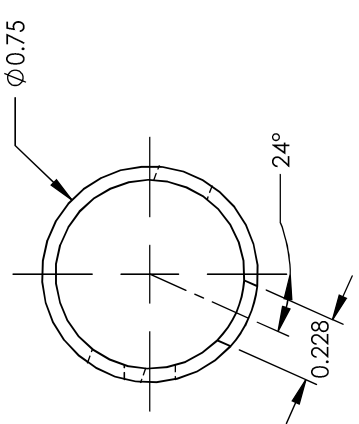
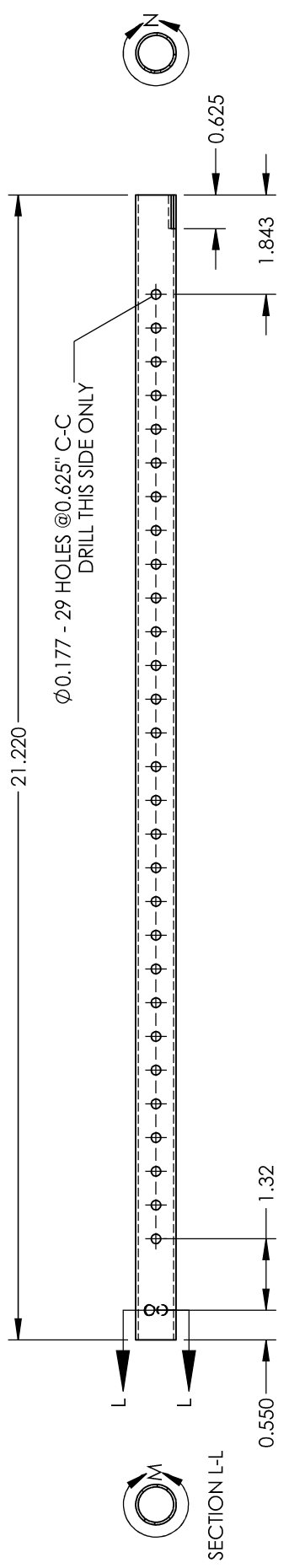

This drawing is the property of Wolf Steel Ltd. or NCC. It is not to be used in any manner without our consent. All rights are reserved.		TITLE: <b>TUBE, SECONDARY AIR #1</b>		MODEL: EPI3-1	DRAWING: <b>W720-0191</b>
		MATERIAL: 18 GA 1.20mm Tubing SS 430-2b		THICKNESS: 0.63 LBS	ISSUE DATE: <b>UNRELEASED</b>
UNLESS OTHERWISE NOTED OR DEPICTED ALL DIMENSIONS ARE OUTSIDE IN INCHES ALL SURFACES ARE CONSIDERED CLASS "D"		FINISH:	PROJECT LEAD: P HODGES	SCALE: 1:3	SHEET 1 OF 1
DIMENSIONS ±0.031 REFERENCE DIMENSIONS ±0.062		TOLERANCES:	REV DATE:	REV NOTE:	CHECKED BY: <b>UNRELEASED</b>
RADIUS ±0.062 ANGLES ±2		DATE FORWAT: MM/DD/YY	REVISION:	3	5

D

C

B

A

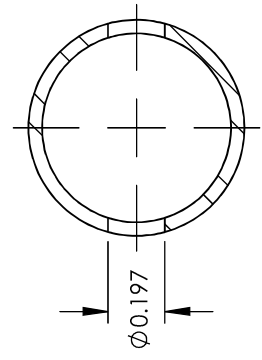
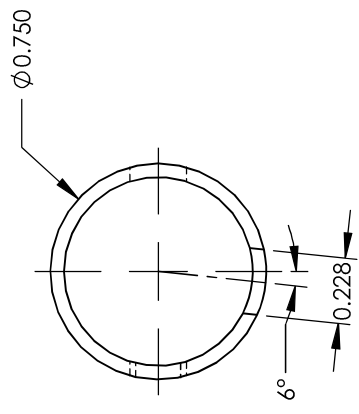
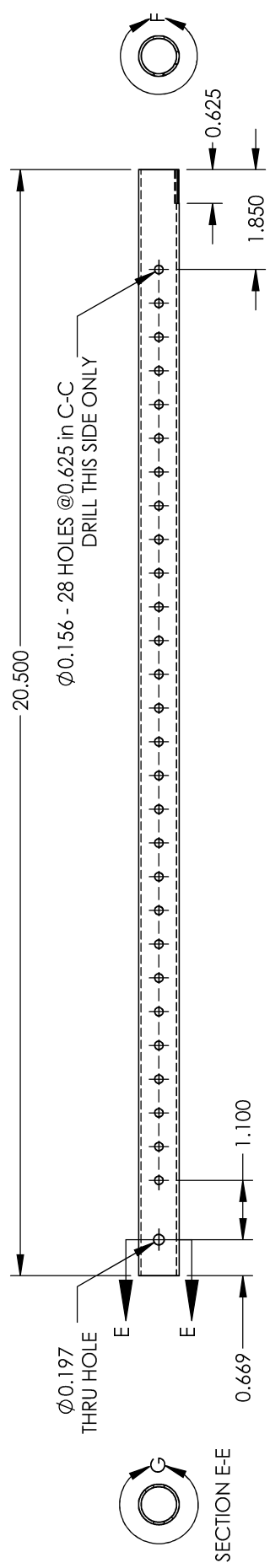

This drawing is the property of Wolf Steel Ltd. or NCC. It is not to be used in any manner without our consent. All rights are reserved.		TITLE: <b>TUBE, SECONDARY AIR #2</b>		MODEL:	EPI3-1	DRAWING: <b>W720-0192</b>
		MATERIAL: 18 GA, 1.20mm Tubing SS 430-2b		THICKNESS:	SHEET 1 OF 1	ISSUE DATE: <b>UNRELEASED</b>
UNLESS OTHERWISE NOTED OR DEPICTED ALL DIMENSIONS ARE OUTSIDE IN INCHES ALL SURFACES ARE CONSIDERED CLASS "D"		FINISH:	PROJECT LEAD: P HODGES	CN#:	SCALE: 1:3	DRAWN BY: <b>MS</b>
DIMENSIONS ±0.031 REFERENCE DIMENSIONS ±0.062		TOLERANCES:	REVISION:	REV DATE:	REV NOTE:	CHECKED BY: <b>UNRELEASED</b>
RADIUS ±0.062 ANGLES ±2				3	4	5

D

C

B

A

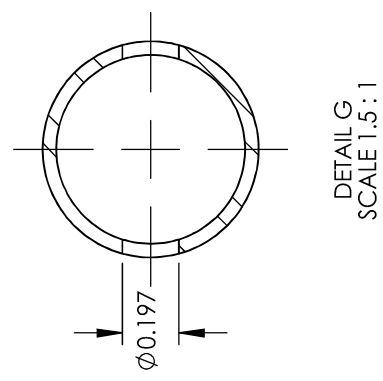
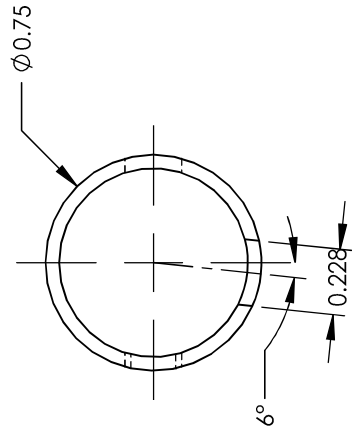
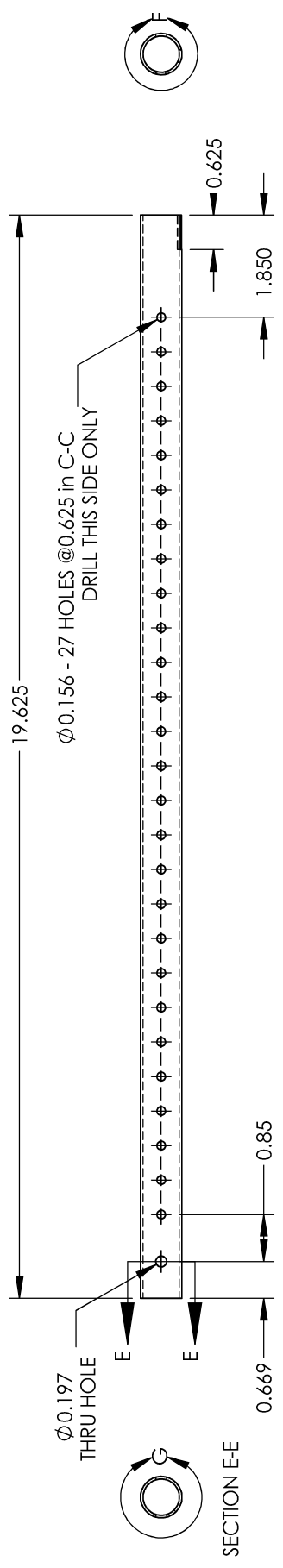

This drawing is the property of Wolf Steel Ltd. or NCC. It is not to be used in any manner without our consent. All rights are reserved.		UNLESS OTHERWISE NOTED OR DEPICTED ALL DIMENSIONS ARE OUTSIDE IN INCHES ALL SURFACES ARE CONSIDERED CLASS "D"		DIMENSIONS ±0.031 REFERENCE DIMENSIONS ±0.062		TOLERANCES: RADIUS ±0.062 ANGLES ±2	TITLE: <b>TUBE, SECONDARY AIR #3</b>	MODEL: EPI3-1	DRAWING: <b>W720-0193</b>
		MATERIAL: 18GA, 1.20mm Tubing SS 430-2b	FINISH:	PROJECT LEAD: P HODGES	THICKNESS: 0.58 LBS	SCALE: 1:3	SHEET 1 OF 1	ISSUE DATE: UNRELEASED	DRAWN BY: MS
		REVISION:	REV DATE:	REV NOTE:	3	4	5	5	5

NOTES:  
 1 THIS EXPLODED VIEW DRAWING IS OF MAJOR COMPONENTS FOR REFERENCE ONLY. REFER TO ENGINEERING MASTER FOR CURRENT BOM  
 2 INDIVIDUAL PARTS MAY NOT BE EXACTLY AS SHOWN. REFER TO PART DRAWING FOR EXACT DETAILS  
 3 FASTENERS MAY NOT BE SHOWN  
 \* ITEM NOT SHOWN

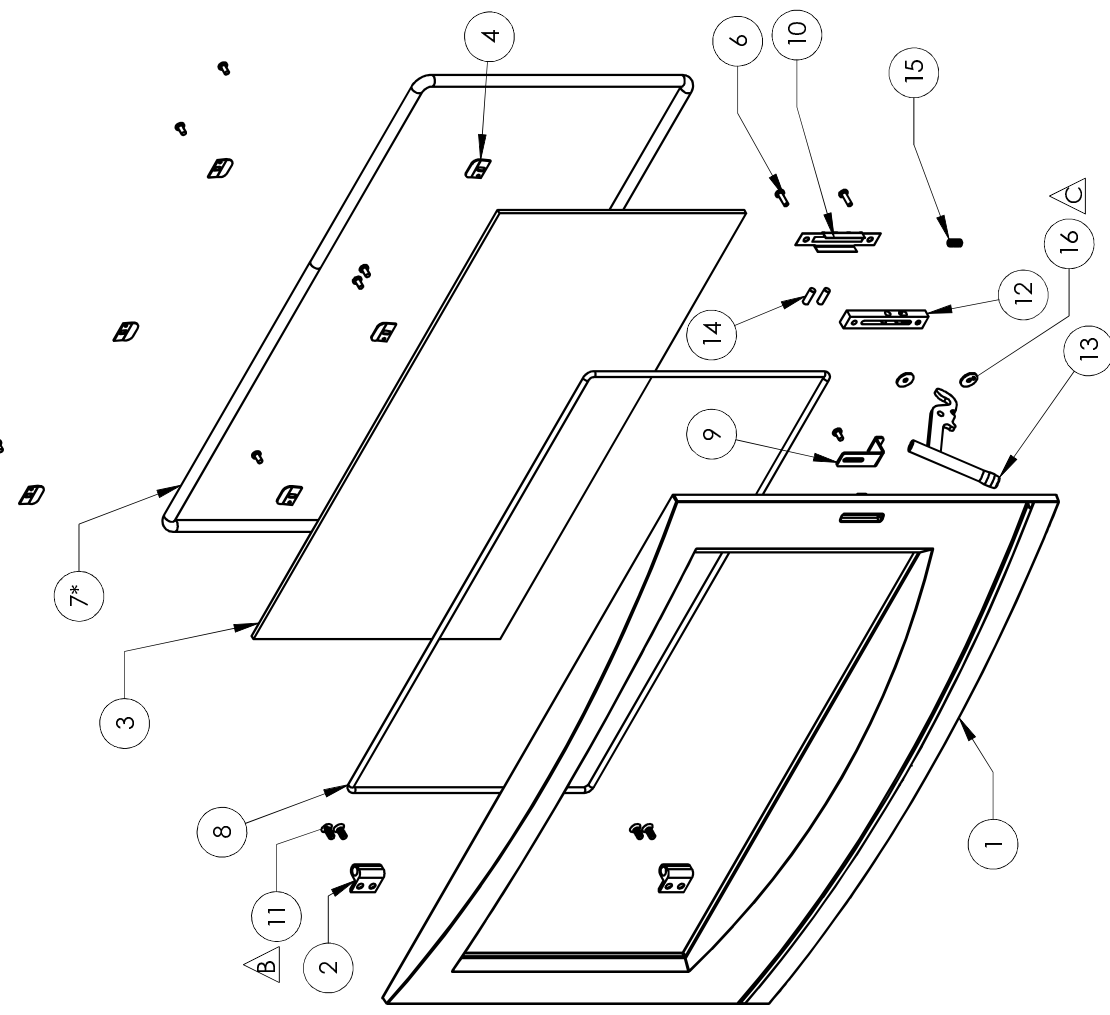

ITEM NO.	QTY.	PART NUMBER	DESCRIPTION
1	1	W135-0724	CASTING, MAIN DOOR (CONTEMPORARY)
2	2	W330-0093	HINGE, UPPER (EP13 (C,T) DOOR) .REPL W330-0083
3	1	W300-0150	GLASS, 25.094" X 12.594" CERAMIC (EP13C)
4	6	W500-0709	RETAINER, GLASS
5	7	W570-0049	SCREW #10-24x3/8"BLK ZNC QUADREX PAN MS
6	2	W570-0082	@SCREW, #10-24 x 5/8" PAN HD (QUAD)
7*	1	W562-0069	GASKET, 1/2" DIA. ROPE
8	1	W562-0043	GASKET, 1/4" DIA. ROPE
9	1	W080-1306	BRACKET, FAN SWITCH
10	1	W500-0700	RETAINER, PIN
11	4	W570-0195	SCREW, MACHINE 1/4-20 9/16"L FH PHILLIPS (UNDERCUT)
12	1	W060-0012	BLOCK, DOOR LATCH
13	1	W325-0077	HANDLE, EP13 DOOR
14	2	W485-0052	PIN, DOWEL 1/4"DIA. X 3/4"L
15	1	W630-0024	SPRING, S4 HANDLE
16	2	W735-0027	WASHER, 0.188 ID x 0.750 OD x .062

UNLESS OTHERWISE NOTED OR DEPICTED ALL DIMENSIONS ARE OUTSIDE IN INCHES ALL SURFACES ARE CONSIDERED CLASS "D" REFER TO ENG-009 AND ENG-010 FOR SURFACE FINISH CRITERIA TOLERANCES: DIMENSIONS ±0.031 REFERENCE DIMENSIONS ±0.062 RADIUS ±0.062 ANGLES ±2	TITLE: <b>ASSEMBLY, CAST DOOR</b>	MODEL: EP13	DRAWING: <b>W010-4221</b>
	MATERIAL:	56.971 LBS	THICKNESS:
FINISH:	P HODGES	CN#:	SCALE: 1:7
REVISION: <b>C</b>	REV DATE: <b>4/24/2018</b>	PROJECT LEAD: P HODGES	SHEET 1 OF 1
DATE FOR WAVE: MM/DD/YY	1	REV NOTE: MOVED THE HINGE PIN TO THE TOP LEVEL ASSY, UPDATED BOM	DRAWN BY: <b>MS</b>
This drawing is the property of Wolf Steel Ltd. or NCC. It is not to be used in any manner without our consent. All rights are reserved.	2	CHECKED BY: <b>CL</b>	ISSUE DATE: <b>5/8/2017</b>

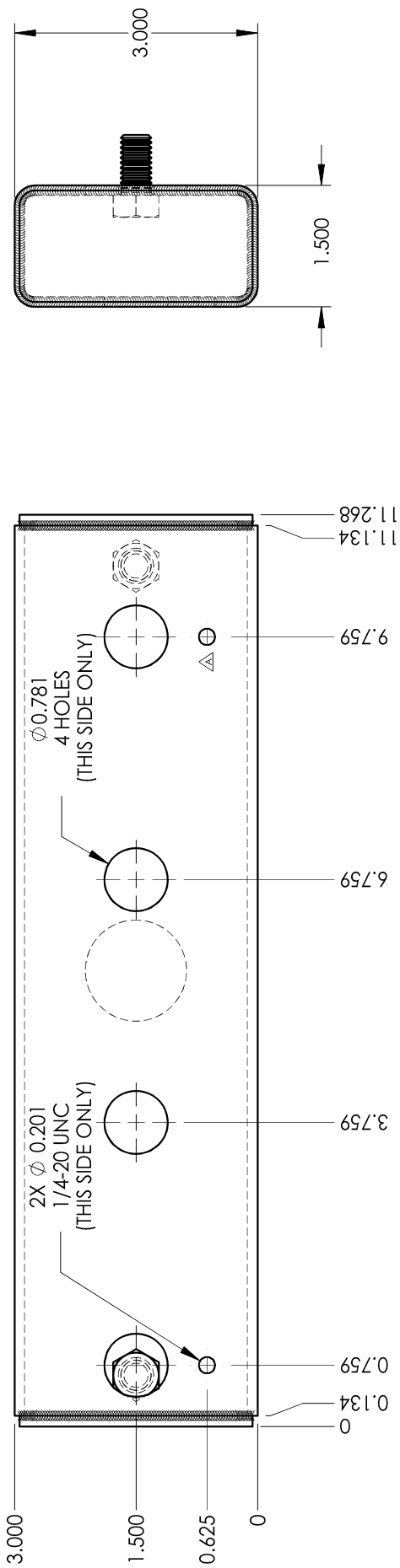
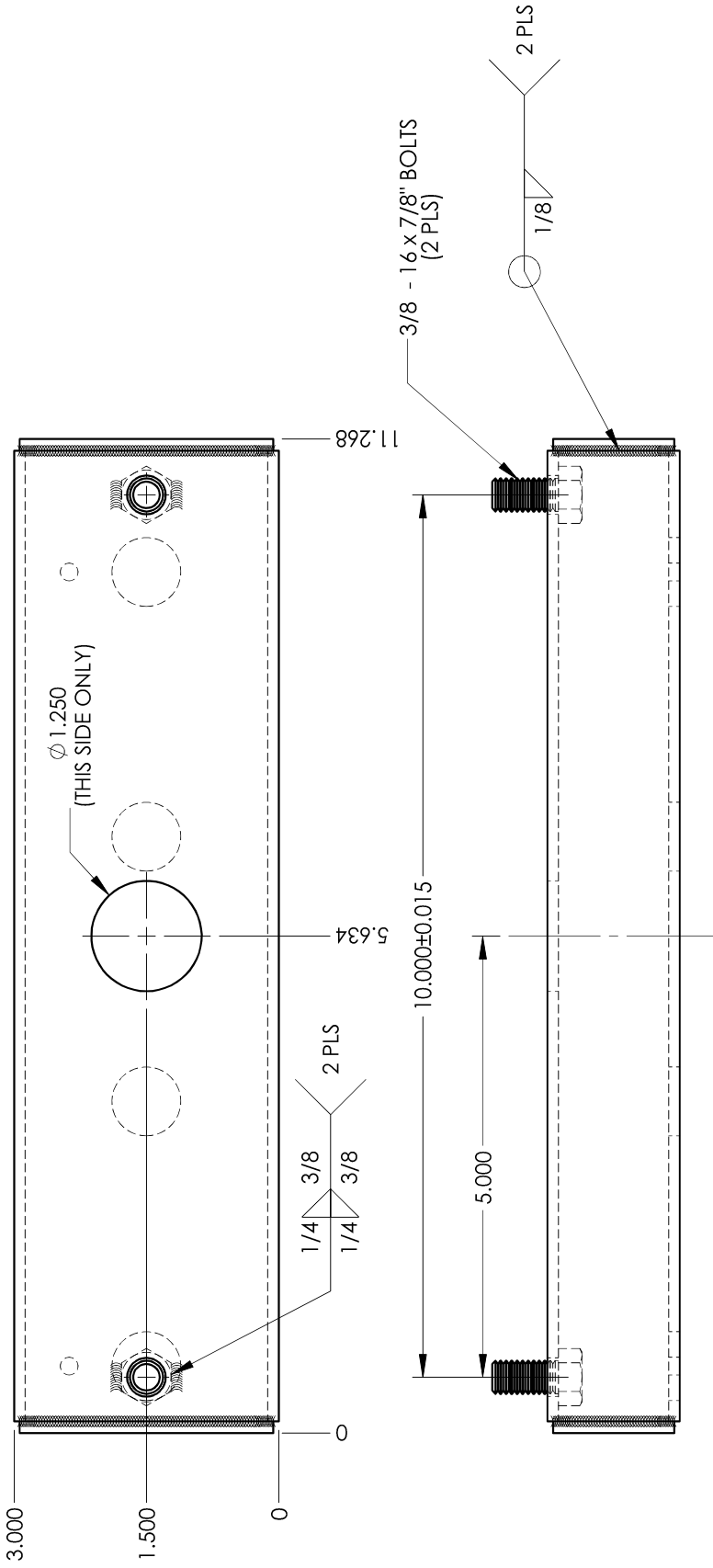

<p><b>WOLF STEEL</b><sup>TM</sup>  <b>NAC</b>  <small>Manufactured in          America          Compliance</small></p>		<p><b>UNLESS OTHERWISE NOTED OR DEPICTED          ALL DIMENSIONS ARE OUTSIDE IN INCHES          ALL SURFACES ARE CONSIDERED CLASS 'B'</b></p> <p><b>TOLERANCES:</b>          DIMENSIONS ±0.03"          REFERENCE DIMENSIONS ±0.02"          ANGLES ±2°</p>		<p><b>TITLE:</b> ASSEMBLY, S/A CHAMBER (LS)</p>	<p><b>MODEL:</b> EP13</p>	<p><b>DRAWING:</b> W010-2530</p>
<p><b>MATERIAL:</b> 3.000 x 1.500 x 0.125 MILD STEEL TUBING</p>		<p><b>SCALE:</b> 1:2</p>	<p><b>FINISH:</b></p>	<p><b>MATERIAL:</b> 0.447 LBS</p>	<p><b>DRAWN BY:</b> A.RIGDEN</p>	
<p><b>REVISION:</b> A</p>		<p><b>DATE:</b> 7/6/2012</p>	<p><b>SHEET 1 OF 1</b></p>	<p><b>SCALE:</b> 1:2</p>	<p><b>CHECKED BY:</b> R.TJART</p>	

This drawing is the property of Wolf Steel LTD. or NAC. It is to be used only for the project and for the quantity specified. No part of this drawing may be reproduced or transmitted in any form or by any means, electronic, mechanical, photocopying, recording, or by any information storage and retrieval system, without our consent. All rights are reserved.

10/09/12 AR

ITEM NO.	QTY.	PART NUMBER	DESCRIPTION
1	1	W190-0043	CONTROL, AIR
2	1	W080-1176	BRACKET, AIR CONTROL

THIS SURFACE MUST BE FREE OF BURRS OR WELD SLAG

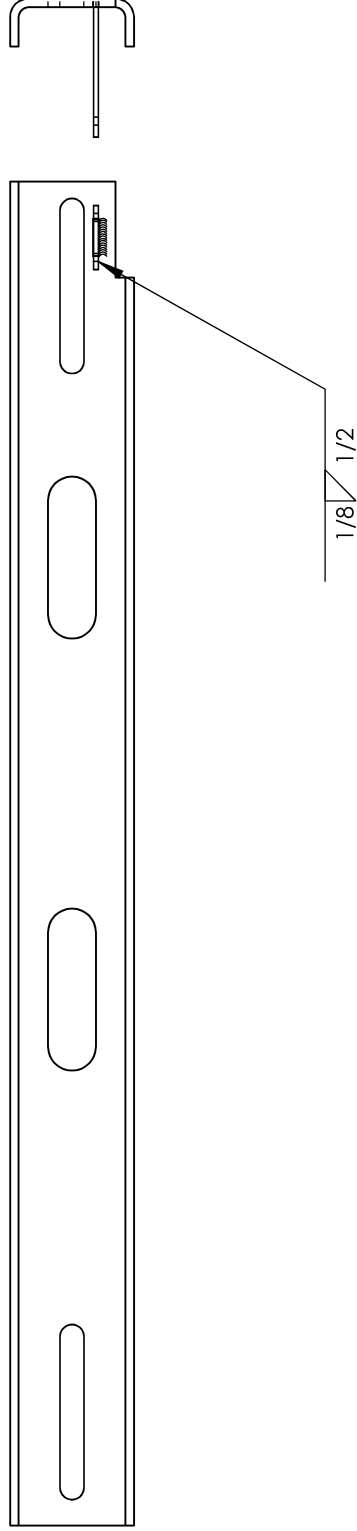
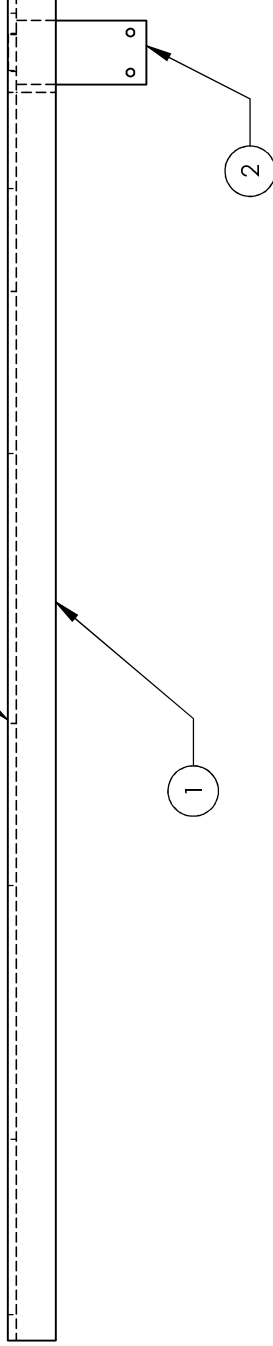

This drawing is the property of Wolf Steel LTD., or NAC. It is not to be used, copied, or reproduced without our consent. All rights are reserved.

**WOLF STEEL LTD.**  
**NAC**  
 Precision in  
 Air Control  
 Components

**UNLESS OTHERWISE NOTED OR DEPICTED ALL DIMENSIONS ARE OUTSIDE IN INCHES ALL SURFACES ARE CONSIDERED CLASS "D"**

**TOLERANCES:**  
 DIMENSIONS ±0.031"  
 REFERENCE DIMENSIONS ±0.063"  
 ANGLES ±2°

**TITLE: ASSEMBLY, AIR CONTROL**

**FINISH:**

**REVISION: -**

**MODEL:** EP13

**SCALE:** 1:3

**SHEET 1 OF 1**

**DRAWING:** W010-2548

**DRAWN BY:** A.RIGDEN

**CHECKED BY:** R.TJART



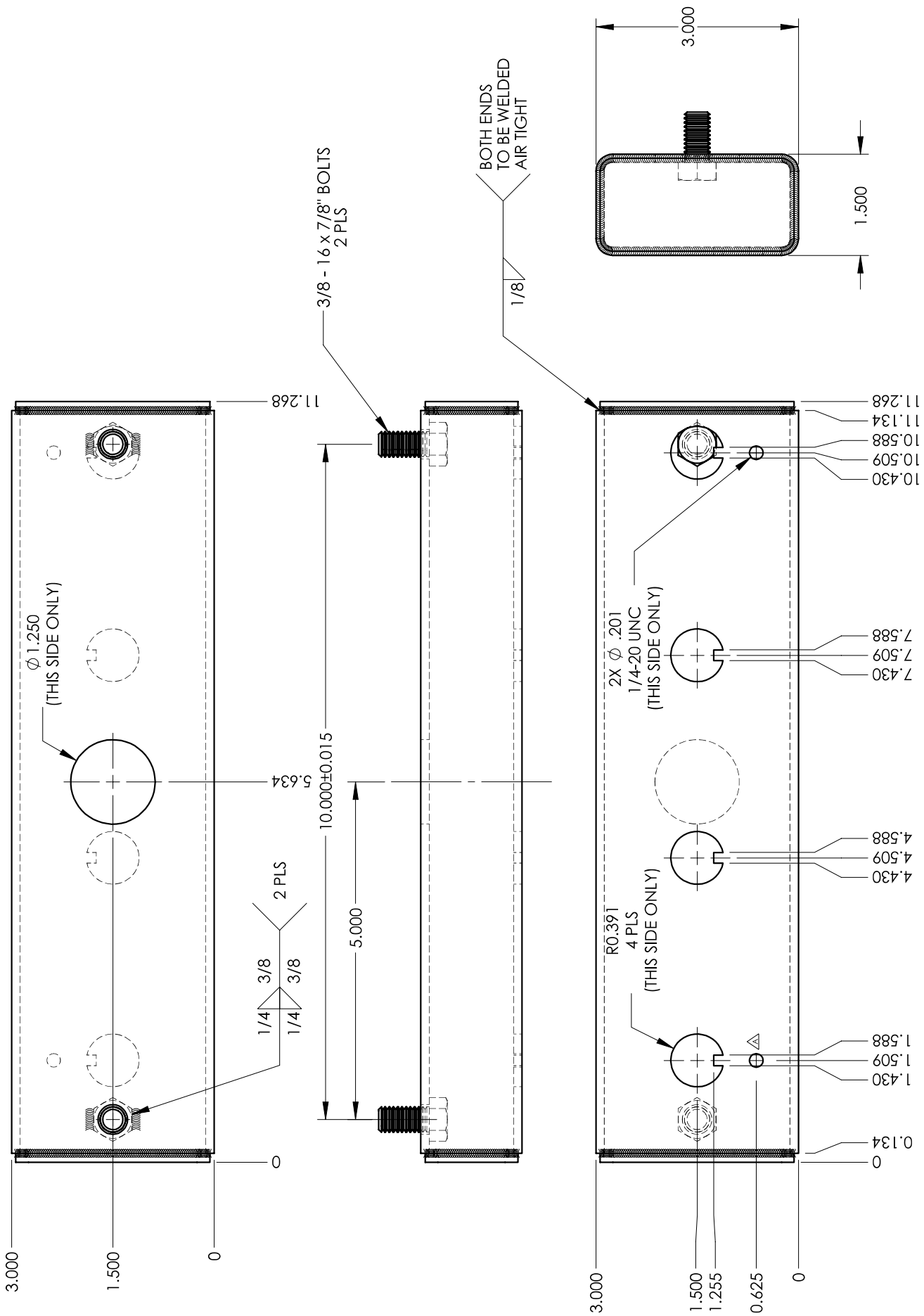

<p>UNLESS OTHERWISE NOTED OR DEPICTED ALL DIMENSIONS ARE OUTSIDE IN INCHES ALL SURFACES ARE CONSIDERED CLASS D*</p> <p>TOLERANCES:</p> <p>DIMENSIONS ±0.031"</p> <p>REFERENCE DIMENSIONS ±0.063"</p> <p>ANGLES ±2°</p>		<p>MODEL: EP13</p> <p>MODEL: 0.448 LBS</p> <p>SCALE: 1:2</p>	<p>DRAWING: W010-2797</p> <p>DRAWN BY: A.RIGDEN</p> <p>MM/DD/YYYY: 6/13/2012</p> <p>CHECKED BY: R.TJART</p>
<p>TITLE: ASSEMBLY, S/A CHAMBER (RS)</p> <p>3.000 x 1.500 x 0.125 MILD STEEL TUBING</p>		<p>SHEET 1 OF 1</p>	<p>REVISION: A</p> <p>7/6/2012 (AGR) MOVE HOLES</p>
<p>FINISH:</p>		<p>FINISH:</p>	<p>FINISH:</p>

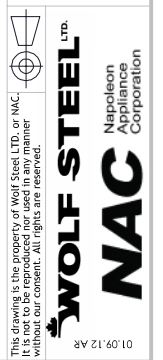

ITEM NO.	QTY.	PART NUMBER	DESCRIPTION
1	1	W035-0288	BASE, OUTER SHELL
2	1	W150-0063	CHANNEL, BLOWER AIR

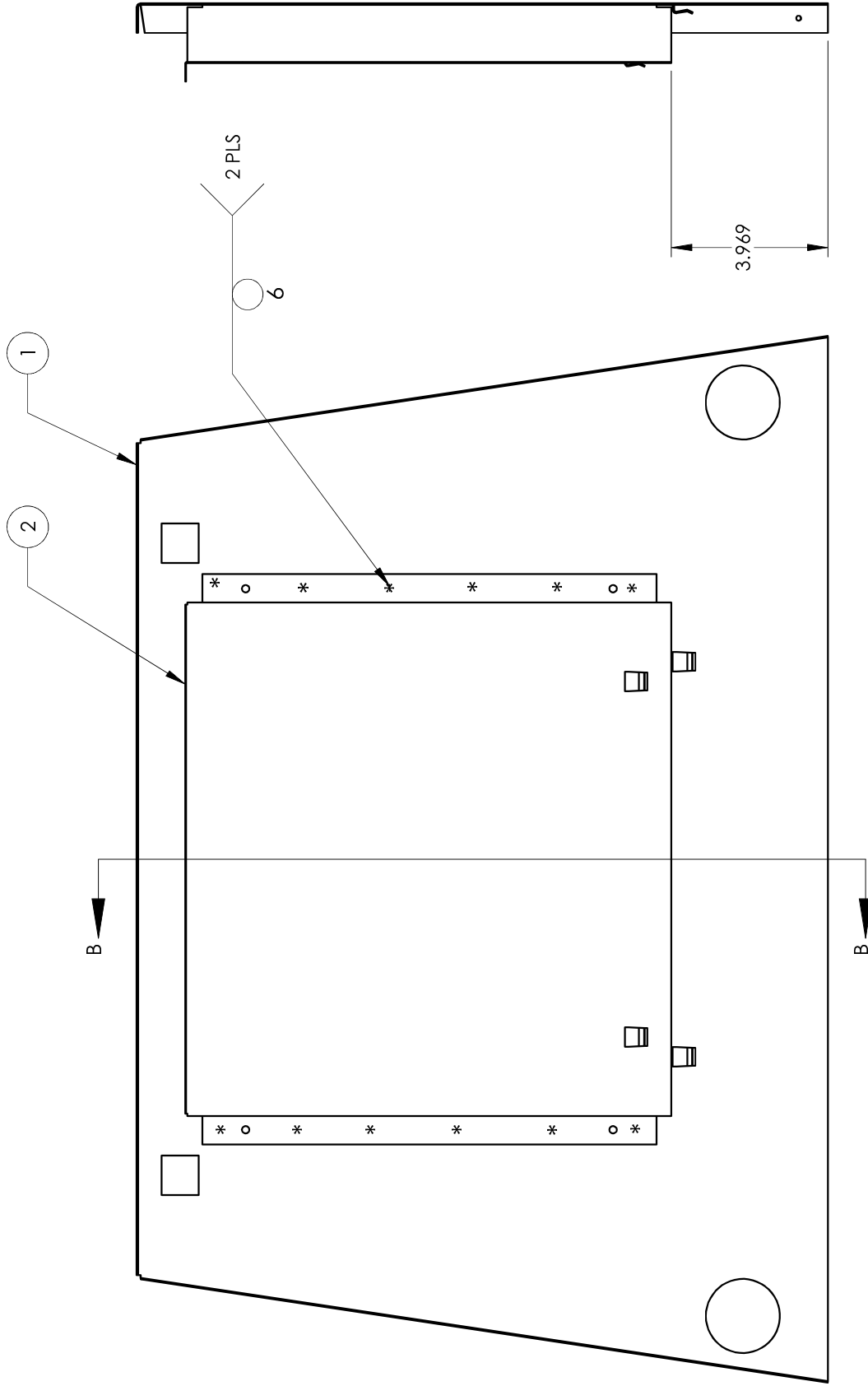

SECTION B-B

UNLESS OTHERWISE NOTED OR DEPICTED ALL DIMENSIONS ARE OUTSIDE IN INCHES ALL SURFACES ARE CONSIDERED CLASS "D"		TITLE:	MODEL:	EPT3	DRAWING:
TOLERANCES: DIMENSIONS: +0.031" REFERENCE DIMENSIONS: ±0.063" ANGLES: ±2°		<b>ASSEMBLY, OUTER BASE</b>	6.635 LBS		<b>W010-2858</b>
		FINISH:	SCALE: 1:4	SHEET 1 OF 1	DRAWN BY: <b>A.RIGDEN</b>
		REVISION: <b>A</b>	<b>2/27/2013</b> (AGR) UPDATE VIEWS		6/13/2012
					CHECKED BY: <b>R.TJART</b>

This drawing is the property of Wolf Steel LTD., or NAC. It is to be used only for the project and location specified hereon. All rights are reserved.

**WOLF STEEL LTD.**  
**NAC** Erectors in  
All Trades  
CORPUS CHRISTI, TX

01.09.12 AR

NOTE: LOCATE PARTS USING FIXTURE NUMBERS 3130 AND 3124

ITEM NO.	QTY.	PART NUMBER	DESCRIPTION
1	1	W705-0276	TOP, FIREBOX
2	1	W655-0404	STIFFNER, FIREBOX TOP
3	1	W150-0064	CHANNEL, AIR WASH
4	2	W500-0691	RETAINER, FLUE COLLAR

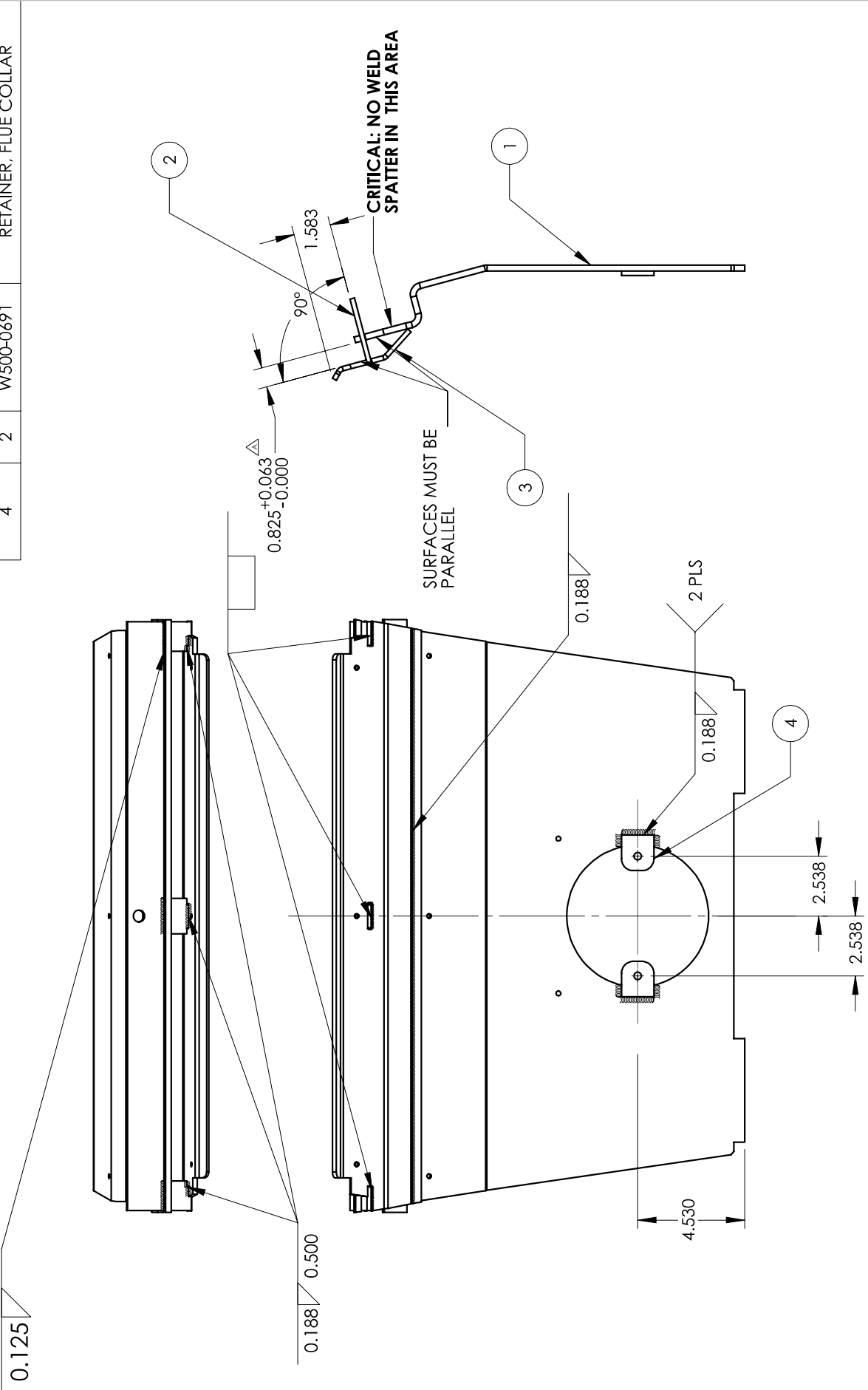

UNLESS OTHERWISE NOTED OR DEPICTED ALL DIMENSIONS ARE OUTSIDE IN INCHES ALL SURFACES ARE CONSIDERED CLASS "D" <b>TOLERANCES:</b> DIMENSIONS ±0.031" REFERENCE DIMENSIONS ±0.063" ANGLES ±2°	<b>TITLE:</b> ASSEMBLY, FIREBOX TOP WELDMENT	<b>MODEL:</b> 33,980 LBS	<b>EPT3</b>	<b>DRAWING:</b> W010-2884
	<b>FINISH:</b>	<b>SCALE:</b> 1:6	<b>SHEET 1 OF 1</b>	<b>DRAWN BY:</b> A.RIGDEN
<b>REVISION:</b> B	<b>01/30/13</b> (AGR) MODIFY DIM	<b>CHECKED BY:</b> R.TJART	<b>DATE:</b> 06/27/12	<b>DATE:</b> 06/27/12

**WOLF STEEL**<sup>INC.</sup>  
 Napoleon  
 America  
 Corporation  
**NAC**

01.09.12 AR

ITEM NO.	QTY.	PART NUMBER	DESCRIPTION
1	1	W500-0737	RETAINER, CASTING (REPLACES W500-0639)
2	2	W450-0012	NUT, WELD 1/4"-20

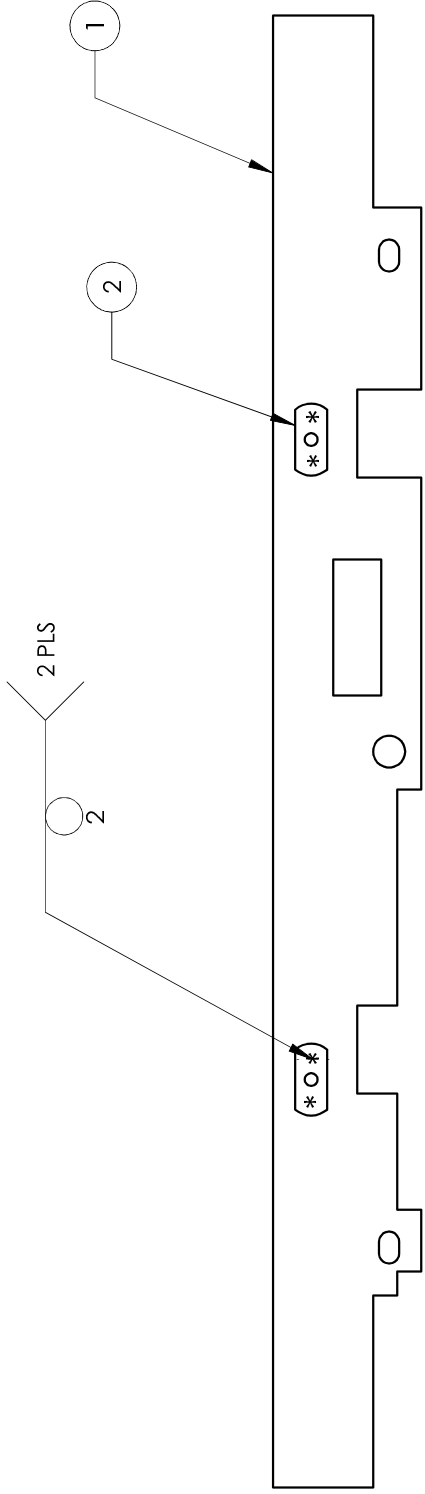

TITLE:	ASSEMBLY, CASTING RETAINER (LS) (REPL W010-2857)	MODEL:	EPI3C	DRAWING:	W010-3060
FINISH:		SCALE:	1:3	DRAWN BY:	A.RIGDEN
REVISION:	-	SHEET:	1 OF 1	MM/DD/YYYY:	6/10/2013
				CHECKED BY:	R.TJART

UNLESS OTHERWISE NOTED OR DEPICTED  
 ALL DIMENSIONS ARE OUTSIDE IN INCHES  
 ALL SURFACES ARE CONSIDERED CLASS "D"  
 TOLERANCES:  
 DIMENSIONS: ±0.031"  
 REFERENCE DIMENSIONS: ±0.063"  
 ANGLES: ±2°

The drawing is the property of Wolf Steel Ltd., or NAC. It is to be used only for the project and for the quantity specified. All rights are reserved.

**WOLF STEEL**<sup>TM</sup>  
**NAC**  
 Precision in  
 Castings  
 Components

01.09.12 AR

ITEM NO.	QTY.	PART NUMBER	DESCRIPTION
1	1	W500-0737	RETAINER, CASTING (REPLACES W500-0639)
2	2	W450-0012	NUT, WELD 1/4"-20

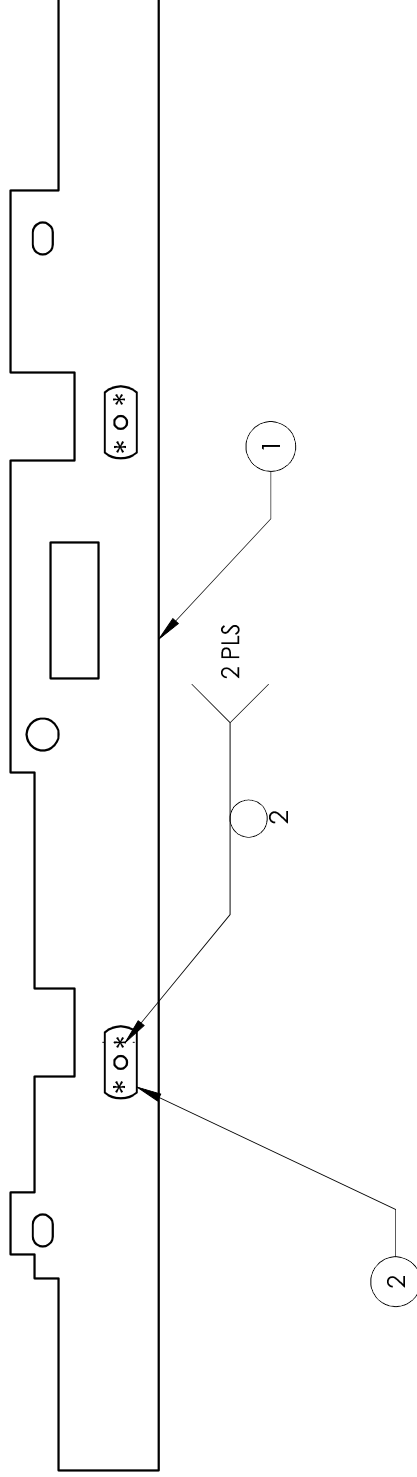

TITLE:	ASSEMBLY, CASTING RETAINER (RS) (REPL W010-2856)	MODEL:	EPI3C	DRAWING:	W010-3061
FINISH:		0.884 LBS		DRAWN BY:	A.RIGDEN
REVISION:	-	SCALE: 1:3	SHEET 1 OF 1	MM/DD/YYYY:	6/13/2013
				CHECKED BY:	R.TJART

UNLESS OTHERWISE NOTED OR DEPICTED  
 ALL DIMENSIONS ARE OUTSIDE IN INCHES  
 ALL SURFACES ARE CONSIDERED CLASS "D"

TOLERANCES:  
 DIMENSIONS: ±0.031"  
 REFERENCE DIMENSIONS: ±0.063"  
 ANGLES: ±2°

The drawing is the property of Wolf Steel LTD., or NAC. It is to be used only for the project and for the customer named herein. All rights are reserved.

**WOLF STEEL**<sup>TM</sup>  
**NAC**  
 NORTH AMERICAN  
 CASTING COMPANY

01.09.12 AR

ITEM NO.	QTY.	PART NUMBER	DESCRIPTION
1	1	W500-0750	RETAINER, DOOR ROLLER (REPL W500-0637)
2	1	W080-1336	BRACKET, DOOR ROLLER (REPL W080-1283)

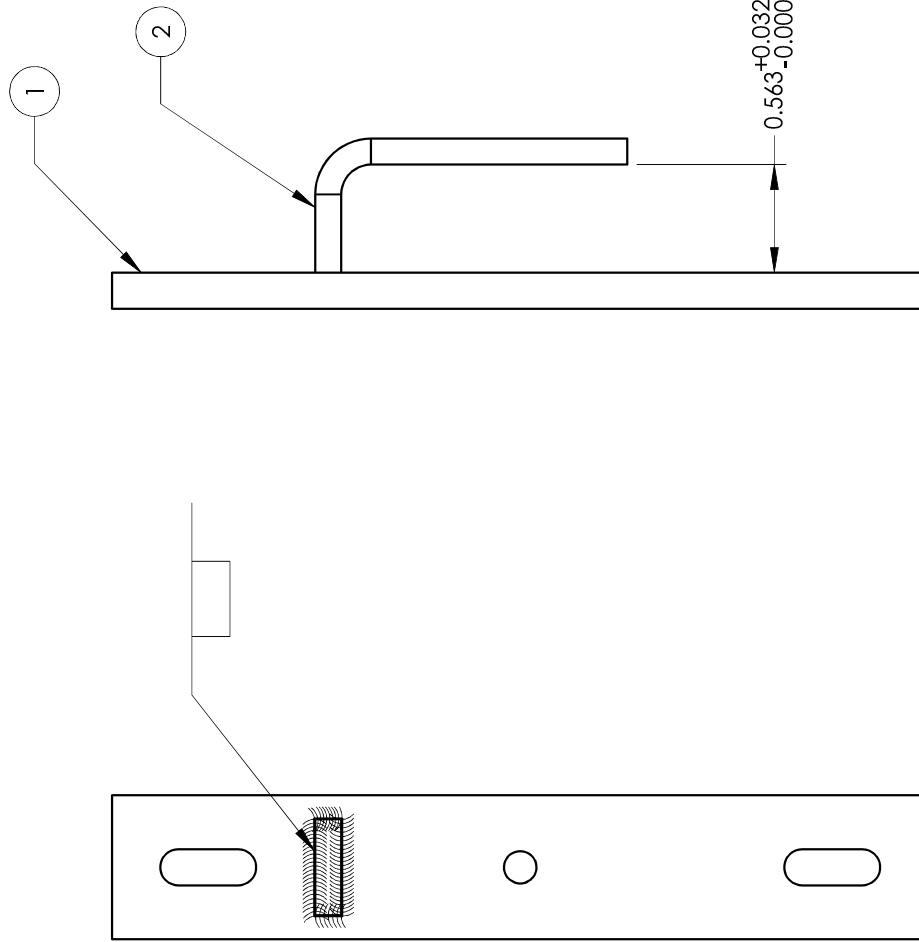

  
**WOLF STEEL**
  
**NAC**
  

 The drawing is the property of Wolf Steel Ltd., or NAC. It is to be used only for the project and for the quantity specified. All rights are reserved.
 
  

 NAC Steel Ltd.
   
 10000 10th Ave. S.E.
   
 Calgary, Alberta

UNLESS OTHERWISE NOTED OR DEPICTED  
 ALL DIMENSIONS ARE OUTSIDE IN INCHES.  
 ALL SURFACES ARE CONSIDERED CLASS 'D'  
 REFER TO ENG-009 AND ENG-010  
 FOR SURFACE FINISH CRITERIA  
 DIMENSIONS ±0.031 ANGLES ±2°  
 REFERENCE DIMENSIONS ±0.003 RADIUS ±0.031

TITLE:	ASSY, DOOR ROLLER WLDMNT (REPL W010-2827)	MODEL:	EPI3C	DRAWING:	W010-3111
FINISH:		SCALE:	1:1	DRAWN BY:	A.RIGDEN
REVISION:	-	SHEET:	1 OF 1	MM/DD/YYYY:	9/4/2013
				CHECKED BY:	R.TJART



ITEM NO.	QTY.	PART NUMBER	DESCRIPTION
1	1	W135-0641	CASTING, MAIN DOOR (TRADITIONAL)
2	2	W485-0052	PIN, DOWEL 1/4"DIA. X 3/4"L
3	1	W325-0077	HANDLE, EP3 DOOR
4	1	W060-0012	BLOCK, DOOR LATCH
5	5	W570-0049	SCREW #10-24x3/8"BLK ZINC QUADREX PAN MS
6	7	W570-0082	@SCREW #10-24 x 5/8" PAN HD (QUAD)
7	4	W500-0709	RETAINER, GLASS
8	1	W300-0146	GLASS, 5MM X 13.594" X 24.188" CERAMIC
9	1	W135-0716	CASTING, GLASS RETAINER (REPLACES W135-0492)
10	2	W330-0093	HINGE, UPPER EP3 (C, T) DOOR, REPL W330-0083
11	1	W630-0024	SPRING, S4 HANDLE
12	1	W562-0002	GASKET, 1/2" DIA. ROPE
13	1	W080-1306	BRACKET, FAN SWITCH
14	1	W562-0043	GASKET, 1/4" DIA ROPE
15	2	W485-0053	PIN, ADJUSTABLE CAM HINGE
16	4	W570-0195	SCREW, MACHINE 1/4-20.9/16"L FH PHILLIPS (UNDERCUT)

A

NOTES:  
 [1] THIS EXPLODED VIEW DRAWING IS OF MAJOR COMPONENTS FOR REFERENCE ONLY. REFER TO ENGINEERING MASTER FOR CURRENT BOM  
 [2] INDIVIDUAL PARTS MAY NOT BE EXACTLY AS SHOWN. REFER TO PART DRAWING FOR EXACT DETAILS  
 [3] FASTENERS MAY NOT BE SHOWN

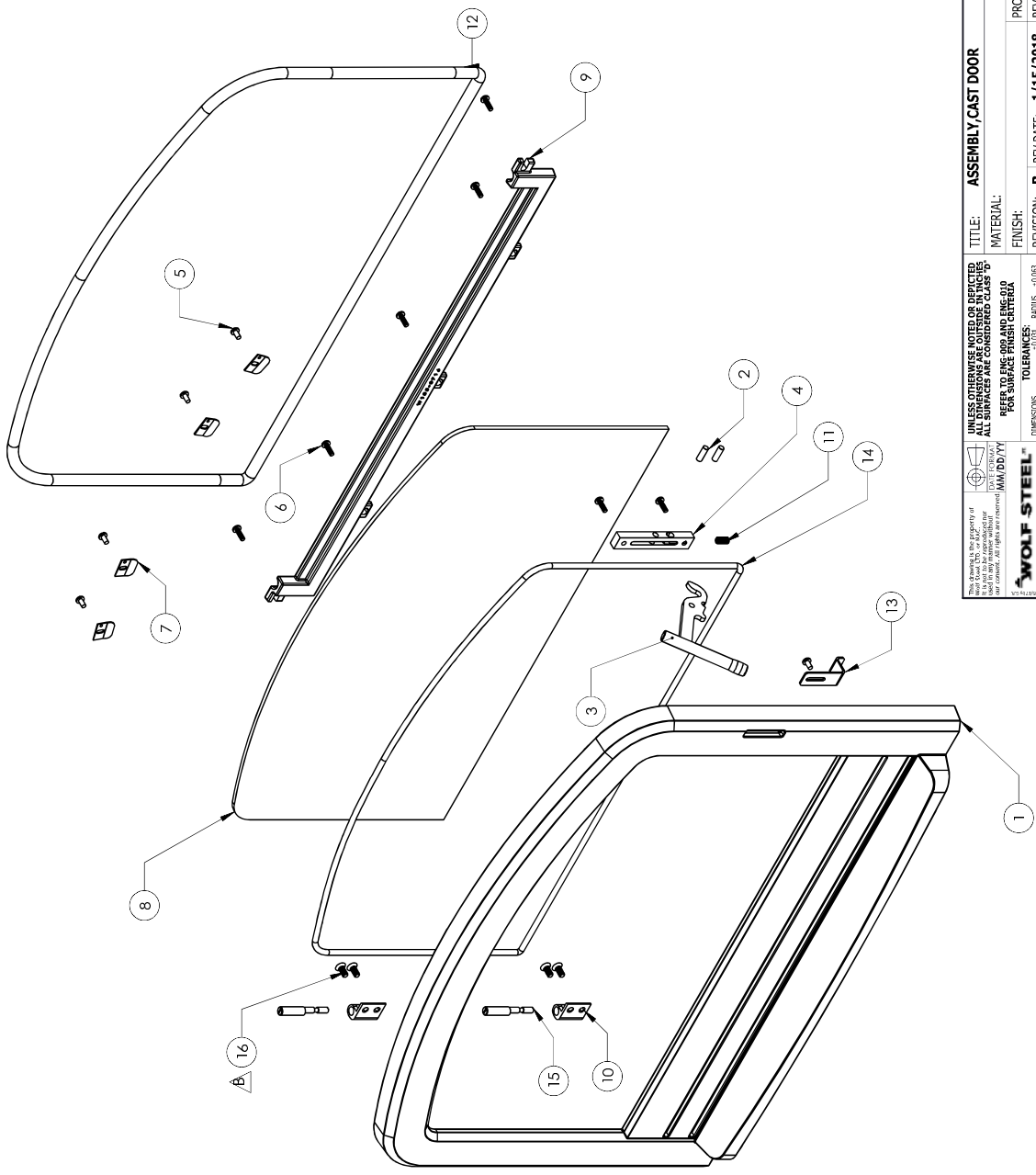

UNLESS OTHERWISE NOTED OR INDICATED OTHERWISE, ALL DIMENSIONS ARE IN INCHES AND DECIMALS THEREOF. ALL SURFACES ARE CONSIDERED CLASS 20. REFER TO ENG 000 AND ENG 010 FOR SURFACE FINISH CRITERIA. DIMENSIONS: TOLERANCES: ANGLES: ±0.003 ±0.002 ±0.002

**WOLF STEEL**™  
 100% U.S. STEEL  
 MADE IN THE U.S.A.  
 ALL RIGHTS ARE RESERVED. MM/DD/YY

TITLE: **ASSEMBLY, CAST DOOR**  
 MATERIAL: **41-972 LBS**  
 FINISH: **P HODGES**  
 REVISION: **B** REV DATE: **1/15/2018** REV NOTE: **UPDATED BILL OF MATERIAL.**

MODEL: **EP3 DRAWING: W010-4219**  
 THICKNESS: **1:7** SCALE: **1:7** SHEET 1 OF 1 DRAWN BY: **MS**  
 PROJECT LEAD: **MS** ISSUE DATE: **5/8/2017**  
 CHECKED BY: **CL**





ITEM NO.	QTY.	PART NUMBER	DESCRIPTION
1	1	W190-0043	CONTROL, AIR
2	1	W080-1176	BRACKET, AIR CONTROL

THIS SURFACE MUST BE FREE OF BURRS OR WELD SLAG

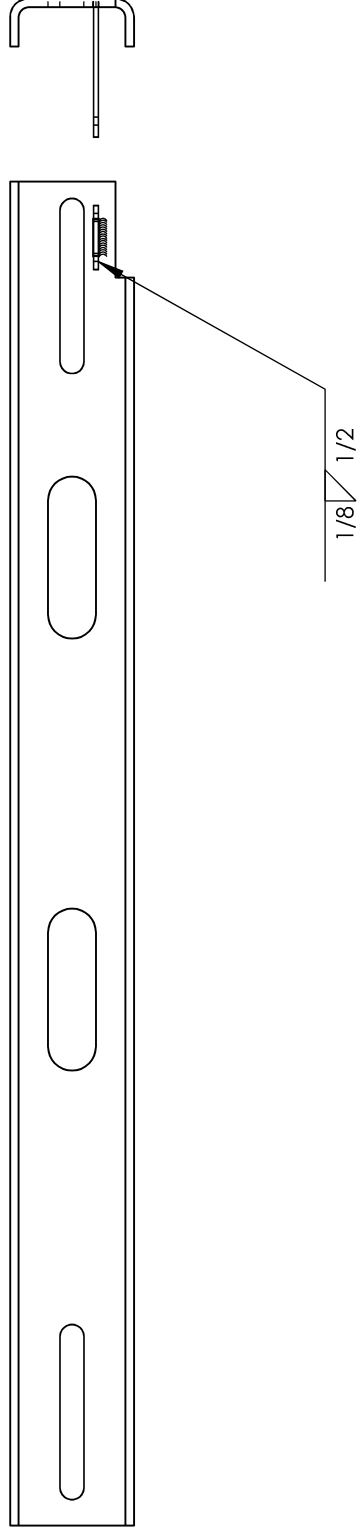
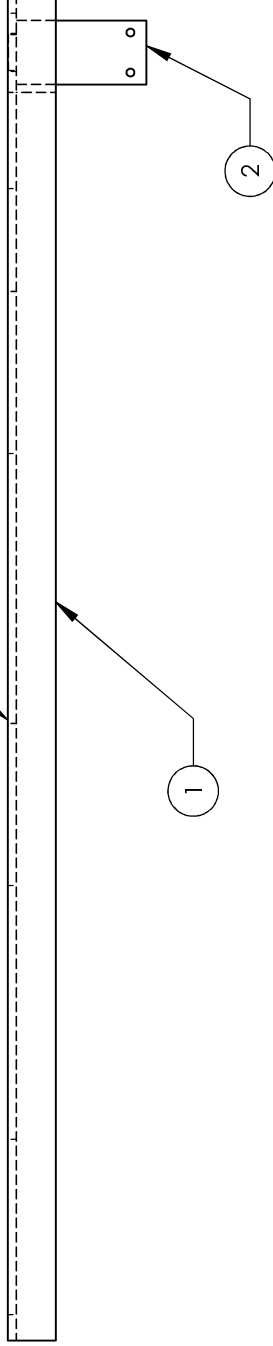

01.09.12 AR

**WOLF STEEL**<sup>TM</sup>  
**NAC**

Product of  
AISI 304 SS  
C-10710-001-01

UNLESS OTHERWISE NOTED OR DEPICTED  
ALL DIMENSIONS ARE OUTSIDE IN INCHES  
ALL SURFACES ARE CONSIDERED CLASS "D"

**TOLERANCES:**  
DIMENSIONS ±0.031"  
REFERENCE DIMENSIONS ±0.063"  
ANGLES ±2°

TITLE: **ASSEMBLY, AIR CONTROL**

DRAWING: **W010-2548**

DRAWN BY: **A.RIGDEN**

MM/DD/YYYY: **6/13/2012**

CHECKED BY: **R.TJART**

MODEL: **2.216 LBS**

SCALE: **1:3**

SHEET **1 OF 1**

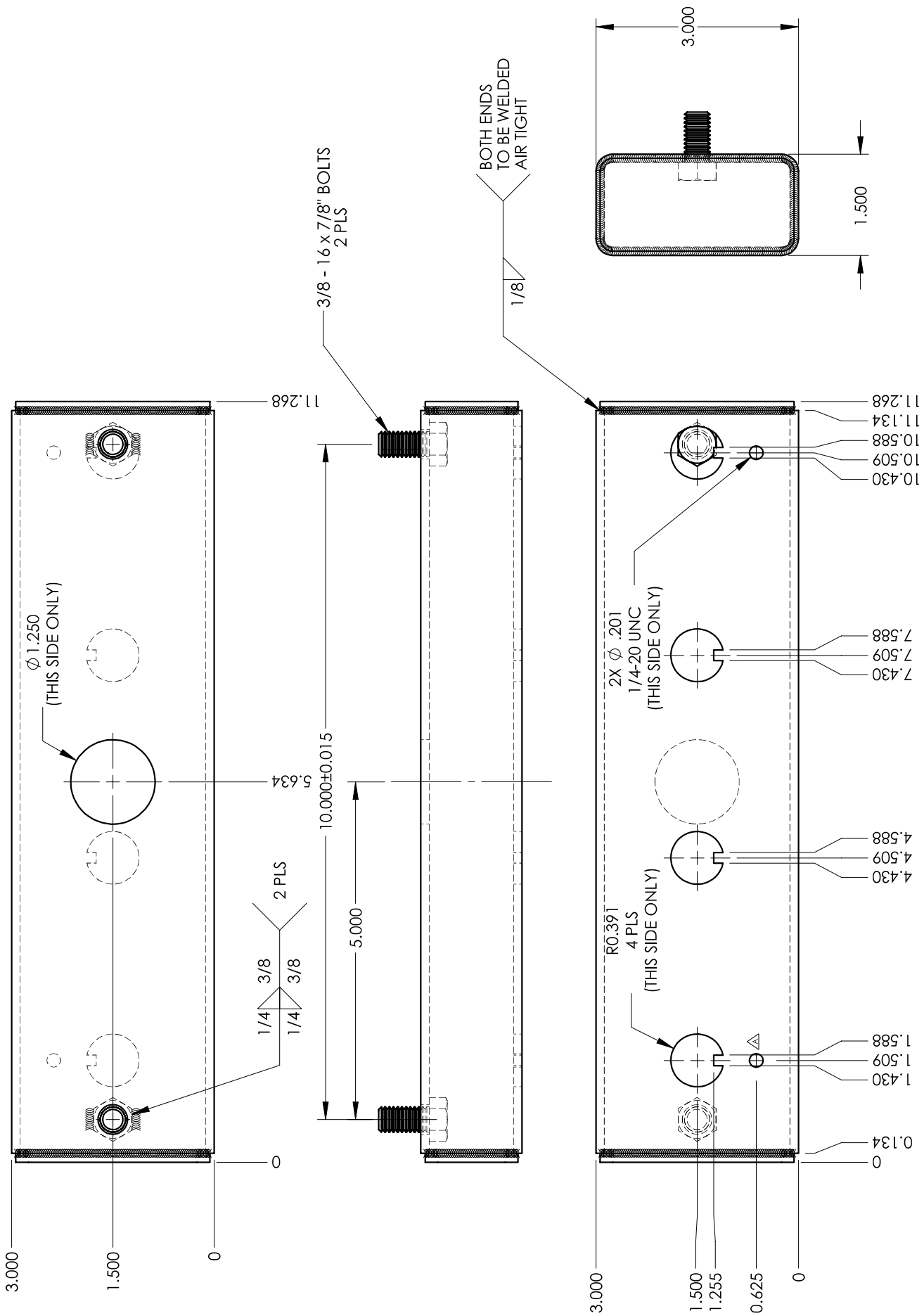

<p>UNLESS OTHERWISE NOTED OR DEPICTED ALL DIMENSIONS ARE OUTSIDE IN INCHES ALL SURFACES ARE CONSIDERED CLASS D*</p> <p>TOLERANCES:</p> <p>DIMENSIONS ±0.031"</p> <p>REFERENCE DIMENSIONS ±0.063"</p> <p>ANGLES ±2°</p>		<p>MODEL: EP13</p> <p>MODEL: 0.448 LBS</p> <p>SCALE: 1:2</p>	<p>DRAWING: W010-2797</p> <p>DRAWN BY: A.RIGDEN</p> <p>MM/DD/YYYY: 6/13/2012</p> <p>CHECKED BY: R.TJART</p>
<p>TITLE: ASSEMBLY, S/A CHAMBER (RS)</p> <p>3.000 x 1.500 x 0.125 MILD STEEL TUBING</p>		<p>SHEET 1 OF 1</p>	<p>REVISION: A</p> <p>7/6/2012 (AGR) MOVE HOLES</p>

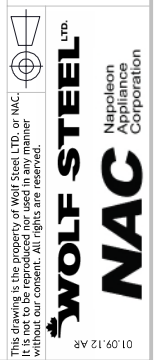

ITEM NO.	QTY.	PART NUMBER	DESCRIPTION
1	1	W035-0288	BASE, OUTER SHELL
2	1	W150-0063	CHANNEL, BLOWER AIR

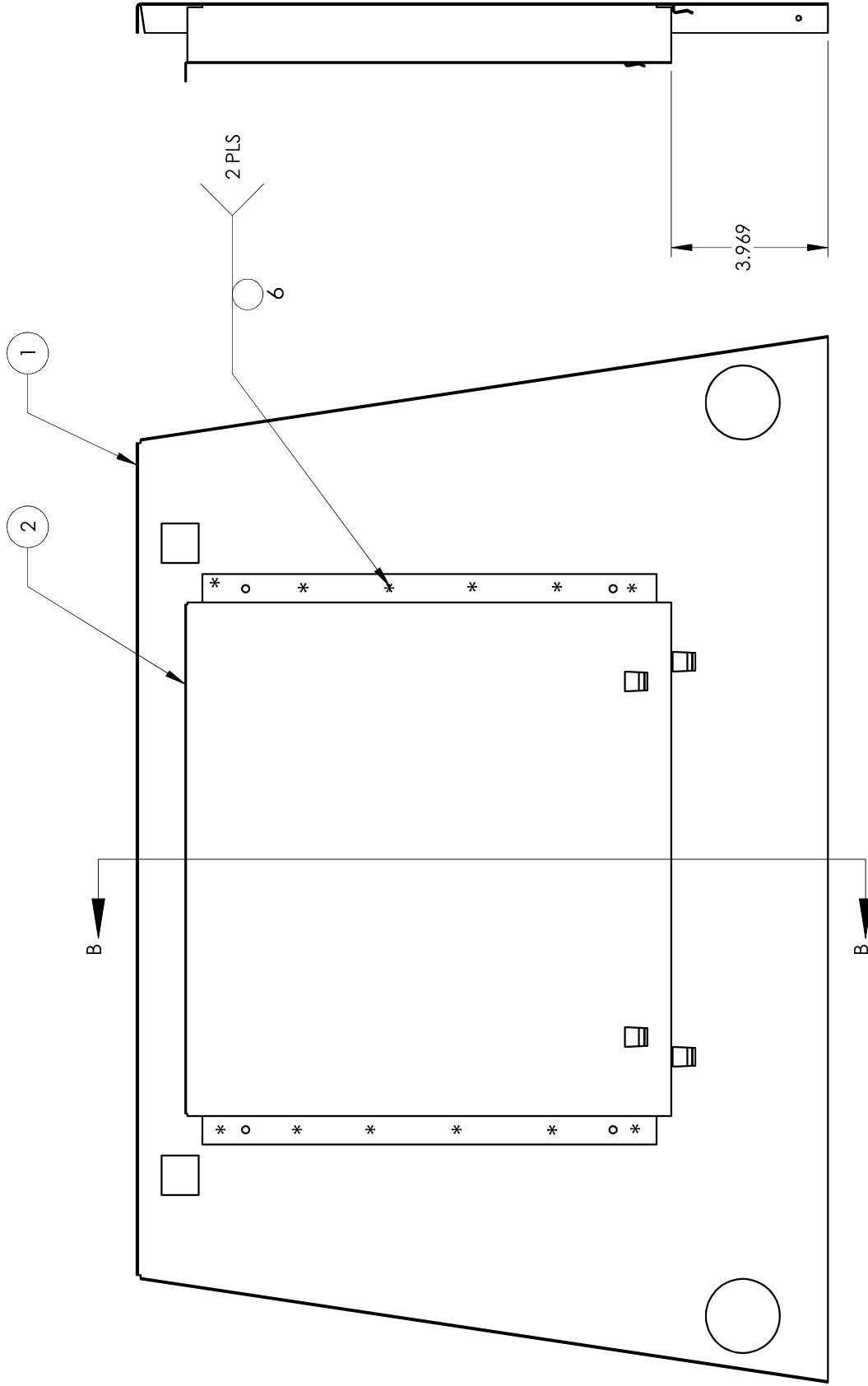

SECTION B-B

UNLESS OTHERWISE NOTED OR DEPICTED ALL DIMENSIONS ARE OUTSIDE IN INCHES ALL SURFACES ARE CONSIDERED CLASS "D"		TITLE:	MODEL:	EPT3	DRAWING:
TOLERANCES: DIMENSIONS: +0.031" REFERENCE DIMENSIONS: ±0.063" ANGLES: ±2°		<b>ASSEMBLY, OUTER BASE</b>	6.635 LBS		<b>W010-2858</b>
		FINISH:	SCALE: 1:4	SHEET 1 OF 1	DRAWN BY: <b>A.RIGDEN</b>
		REVISION: <b>A</b>	<b>2/27/2013</b>	(AGR) UPDATE VIEWS	6/13/2012
					CHECKED BY: <b>R.TJART</b>

This drawing is the property of Wolf Steel LTD., or NAC. It is to be used only for the project and for which it was prepared. All rights are reserved.

**WOLF STEEL LTD.**  
**NAC** Manufacturing & Fabrication

01.09.12 AR

NOTE: LOCATE PARTS USING FIXTURE NUMBERS 3130 AND 3124

ITEM NO.	QTY.	PART NUMBER	DESCRIPTION
1	1	W705-0276	TOP, FIREBOX
2	1	W655-0404	STIFFNER, FIREBOX TOP
3	1	W150-0064	CHANNEL, AIR WASH
4	2	W500-0691	RETAINER, FLUE COLLAR

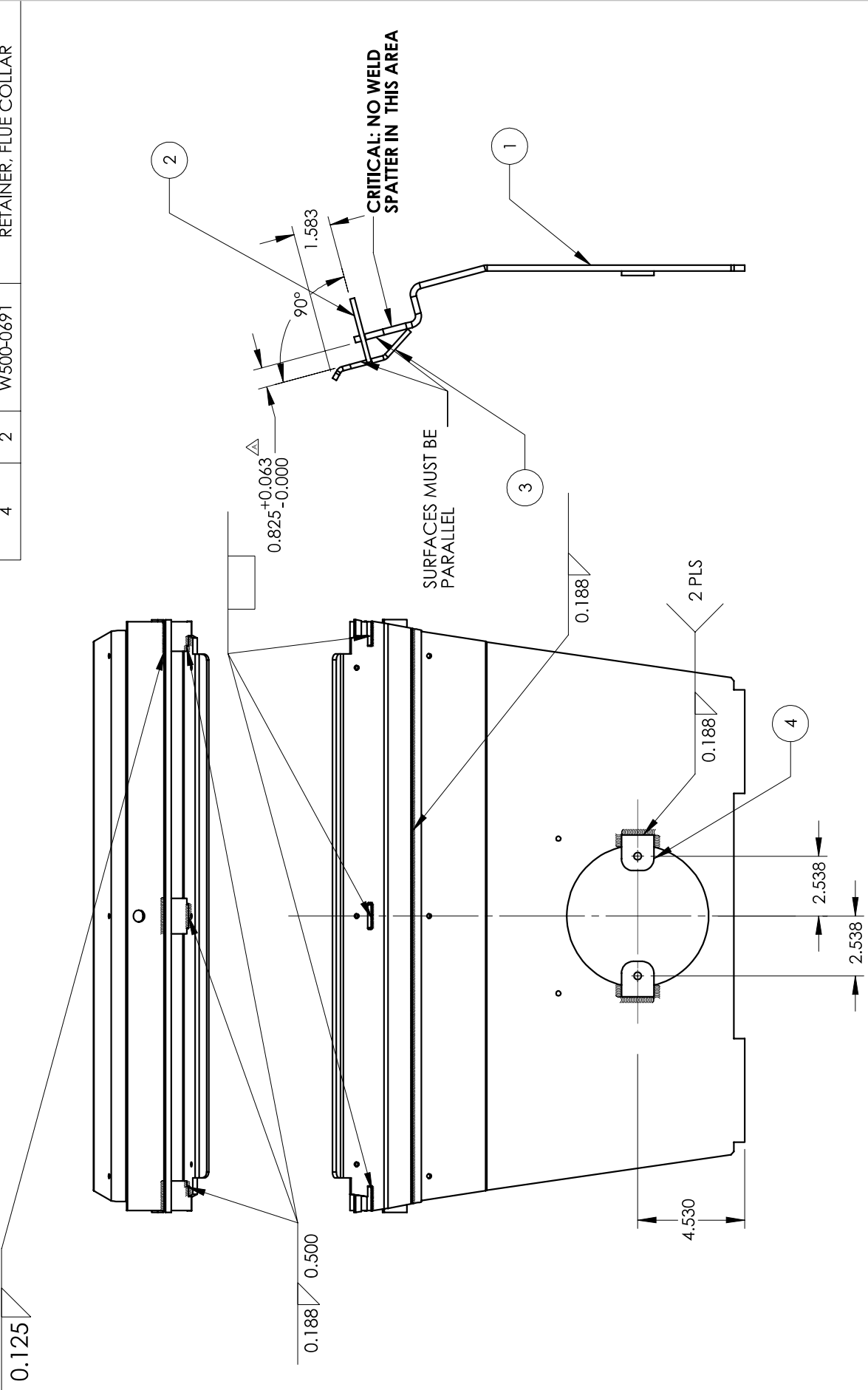

TITLE: ASSEMBLY, FIREBOX TOP WELDMENT		MODEL:	EPT3	DRAWING:	W010-2884
FINISH:		33,980 LBS		DRAWN BY:	A.RIGDEN
REVISION: B		01/30/13 (AGR) MODIFY DIM		SCALE: 1:6	SHEET 1 OF 1
				MM/DD/YYYY:	06/27/12
				CHECKED BY:	R.TJART

UNLESS OTHERWISE NOTED OR DEPICTED  
ALL DIMENSIONS ARE OUTSIDE IN INCHES  
ALL SURFACES ARE CONSIDERED CLASS D"

TOLERANCES:  
DIMENSIONS ±0.031"  
REFERENCE DIMENSIONS ±0.063"  
ANGLES ±2°

The drawing is the property of Wolf Steel Ltd., or NAC. It is to be returned to the originator without our consent. All rights are reserved.

**WOLF STEEL** LTD.  
**NAC** Napoleon American Corporation

01.09.12 AR

**NOTES:**  
 1 THIS EXPLODED VIEW DRAWING IS OF MAJOR COMPONENTS FOR REFERENCE ONLY.  
 2 REFER TO ENGINEERING MASTER FOR CURRENT BOM  
 3 INDIVIDUAL PARTS MAY NOT BE EXACTLY AS SHOWN. REFER TO PART DRAWING FOR EXACT DETAILS  
 4 FASTENERS MAY NOT BE SHOWN

ITEM NO.	QTY.	PART NUMBER	DESCRIPTION
1	1	W060-0011	BLOCK, LATCH PIN
2	1	W105-0017	BUSHING, 1/2" x 3/8"(OD)
3	1	W135-0642	CASTING, FRONT (TRADITIONAL)
4	1	W485-0045	PIN, CASTING PIVOT
5	1	W562-0002	GASKET, 1/2" DIA. ROPE
6	2	W570-0070	SCREW, #10-24 x 1" PAN HD (PHILLIPS)
7	2	W570-0113	SCREW, #10-32 SET
8	1	W330-0094	HINGE, FRONT CASTING LOWER (REPL W330-0084)
9	3	W570-0196	SCREW, MACHINE 1/4-20 3/4"L FH PHILLIPS
10	2	W570-0194	SCREW, MACHINE 1/4-20 1/2"L FH PHILLIPS
11	1	W330-0095	HINGE, LOWER C/W DOOR STOP (REPL W330-0086)
12	1	W570-0160	SCREW, 1/4-20 SET

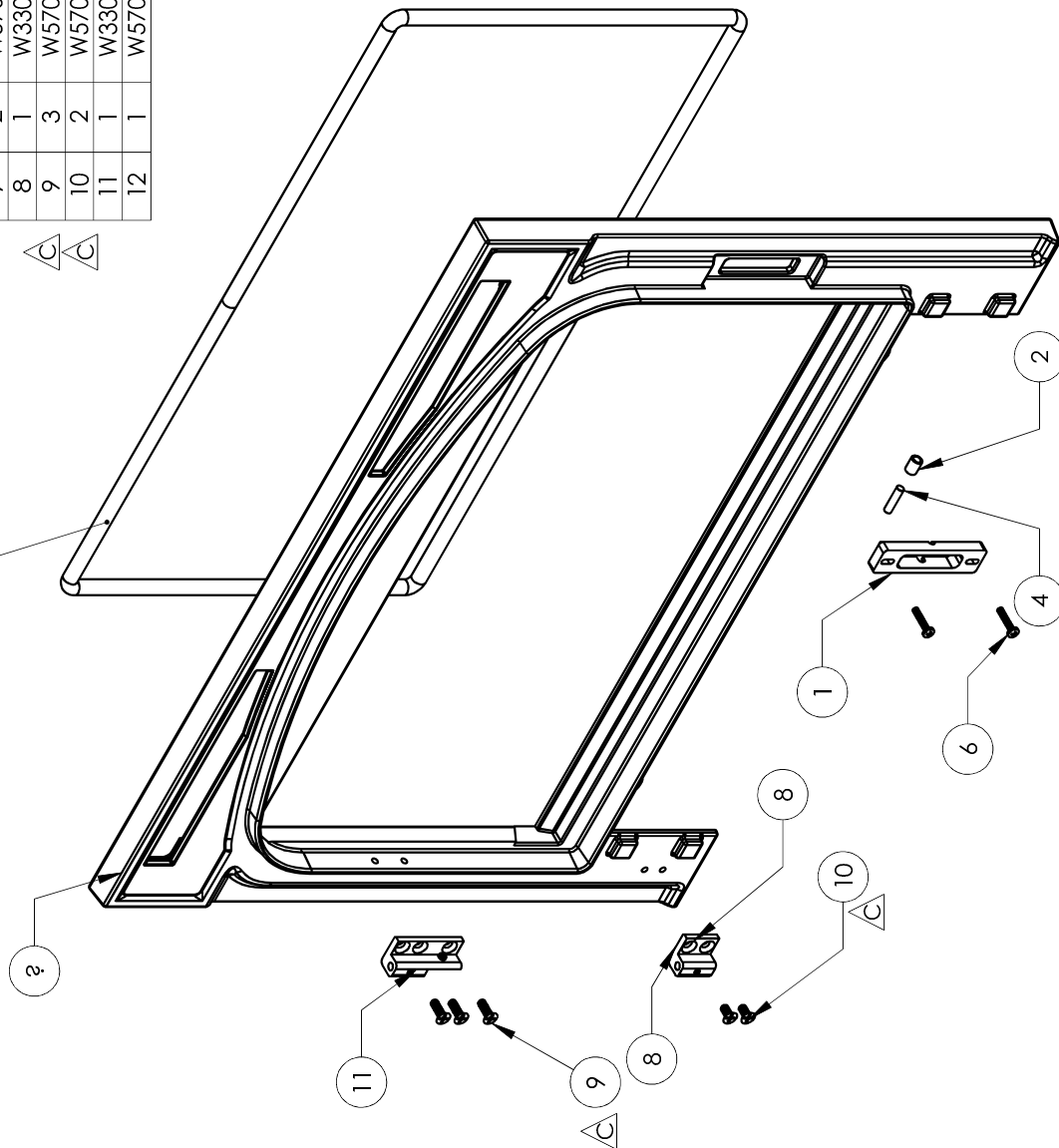

UNLESS OTHERWISE NOTED OR DEPICTED ALL DIMENSIONS ARE OUTSIDE IN INCHES ALL SURFACES ARE CONSIDERED CLASS "D" REFER TO ENG-009 AND ENG-010 FOR SURFACE FINISH CRITERIA		TITLE: <b>ASSEMBLY, CAST FRONT TRADITIONAL</b>		MODEL: EP13 DRAWING: <b>W010-4218</b>	
DIMENSIONS: $\pm 0.031$ REFERENCE DIMENSIONS: $\pm 0.062$		MATERIAL: 35.437 LBS		THICKNESS:	
TOLERANCES: RADIUS $\pm 0.063$ ANGLES $\pm 2$		FINISH:		SCALE: 1:6	
DATE FOR WAVE MM/DD/YY		PROJECT LEAD: P HODGES		SHEET 1 OF 1	
This drawing is the property of Wolf Steel Ltd. or NCC. It is not to be used in any manner without our consent. All rights are reserved.		REVISION: <b>C</b> REV DATE: <b>1/15/2018</b>		DRAWN BY: <b>MS</b>	
<b>WOLF STEEL™</b>		REV NOTE: UPDATED BILL OF MATERIAL		CHECKED BY: <b>CL</b>	

## APPENDIX 7: Operator's manual

This wood appliance needs periodic inspection and repair. It is against United States federal regulations to operate this wood appliance in a manner inconsistent with the operating instructions in this manual.



# INSTALLATION AND OPERATION MANUAL

## INSTALLER:

Leave this manual with the appliance.

## CONSUMER:

Retain this manual for future reference.

## SAFETY INFORMATION

### ! WARNING

If the information in these instructions are not followed exactly, a fire or explosion may result causing property damage, personal injury or death. Please read the entire manual before you install and use your appliance. This heater has not been tested with an unvented gas log set. To reduce risk of fire or injury, do not install an unvented gas log set into the heater.

- This heater can be very hot when burning.
- Combustible materials such as firewood, wet clothing, etc. placed too close can catch fire.
- Children and pets must be kept from touching the heater when it is hot.
- The chimney must be sound and free of cracks. Before installing this appliance, contact the local building or fire authority and follow their guidelines.
- Always operate this appliance with the door(s) or screen (where applicable) tightly closed.
- Burn wood behind the log retainer directly on the firebricks.
- Do not use an elevated grate or otherwise raise the fire.
- This appliance is designed to burn natural wood only. Higher efficiencies and lower emissions generally result when burning air dried seasoned hardwoods, as compared to softwoods or to green or freshly cut hardwoods.
- Do not start a fire with chemicals or fluids such as gasoline, engine oil, etc.
- Do not burn trash or garbage, lawn clippings/waste, rubber, waste petroleum products, paints or paint thinners/solvents, plastic, materials containing asbestos, construction debris, railroad ties or treated wood, manure or animal remains, salt water driftwood or salted materials, unseasoned wood, coal, charcoal, coloured paper, cardboard, plywood or particleboard. Burning these materials may result in release of toxic fumes or render the appliance ineffective and cause smoke.
- Do not let the appliance become hot enough for any part to glow red.

### Wood Stoves ONLY

- At least 14 squares inches (90.3 square centimeters) of outside air must be admitted to the room or directly to the appliance through a 4" (101.6mm) diameter pipe.
- KEEP THE STOVE TOP TEMPERATURE BELOW 700°F (371°C). Attempts to achieve heat output rates that exceed design specifications can result in steel distortion and damage.

## Oakdale™ EPI3-1 Series (EPI3C-1 illustrated)

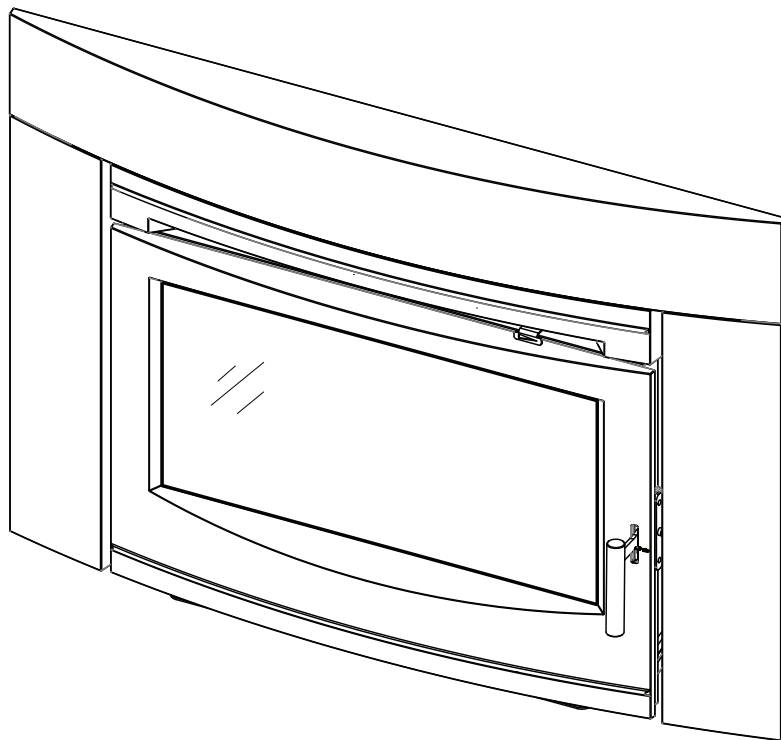

### FOR INDOOR USE ONLY

U.S. Environmental Protection Agency (E.P.A.) certified to comply with 2020 Particulate Emissions Standards using cord wood.  
This appliance has been tested by Services Polytests Inc. and listed by CSA Group to standards: ULC-S628, UL1482.

APPLY SERIAL NUMBER LABEL FROM CARTON



Wolf Steel Ltd., 24 Napoleon Rd., Barrie, ON, L4M 0G8 Canada / 103 Miller Drive, Crittenden, Kentucky, USA, 41030  
Phone 1 (866) 820-8686 • www.napoleon.com • hearth@napoleon.com



## WARNING

- This appliance is hot when operated and can cause severe burns if contacted.
- Any changes or alterations to this appliance or its controls can be dangerous and is prohibited.
- Do not operate appliance before reading and understanding operating instructions. Failure to operate appliance according to operating instructions could cause fire or injury.
- Before installing this appliance, contact the local building or fire authority and follow their guidelines.
- This appliance must be installed by a qualified installer. Never try to repair or replace any part of the appliance unless instructions are given in this manual. All other work should be done by a trained technician.
- Risk of burns. The appliance should be turned off and cooled before servicing.
- Do not operate without fully assembling all components. Do not install damaged, incomplete or substitute components.
- Do not let the appliance become hot enough for any part to glow red.
- Risk of cuts and abrasions. Wear protective gloves, footwear and safety glasses during installation. Sheet metal edges may be sharp.
- All wiring should be done by a qualified electrician and shall be in compliance with local codes. In the absence of local codes, use the current CSA22.1 Canadian Electric Code in Canada or the current National Electric Code ANSI/NFPA No. 70 in the United States.
- If equipped, burning your appliance with the ash dump door ajar creates a fire hazard that may result in discoloration to the door, internal damage to the appliance or a house and/or chimney fire.
- Do not connect this appliance to a chimney flue serving another appliance.
- Clothing or other flammable material should not be placed on or near the appliance. Objects placed in front of the appliance must be kept a minimum of 48" (121.9cm) away from the front face of the appliance.
- Due to high temperatures, the appliance should be located out of traffic and away from furniture and draperies.
- Even after the appliance is off, it will remain hot for an extended period of time.
- Any safety screen or guard removed for servicing must be replaced prior to operating the appliance.
- Under no circumstances should this appliance be modified.
- This appliance must not be connected to a chimney flue pipe servicing a separate solid fuel burning appliance.
- Do not operate the appliance with the glass door removed, cracked or broken. Replacement of the glass should be done by a licensed or qualified service person.
- Do not strike or slam shut the appliance glass door.
- Only doors / optional fronts certified with the appliance are to be installed on the appliance.
- If the appliance is not properly installed, a house fire may result. Do not expose the appliance to the elements (ex. rain, etc.) and keep the appliance dry at all times. Wet insulation will produce an odour when the appliance is used.
- The chimney must be sound and free of cracks. Clean your chimney a minimum of twice a year and as required.
- Children and adults should be alerted to the hazards of high surface temperature and should stay away to avoid burns or clothing ignition.
- Young children should be carefully supervised when they are in the same room as the appliance. Toddlers, young children and others may be susceptible to accidental contact burns. A physical barrier is recommended if there are at risk individuals in the house. To restrict access to an appliance or stove, install an adjustable safety gate to keep toddlers, young children and other at risk individuals out of the room and away from hot surfaces.
- Ensure you have incorporated adequate safety measures to protect infants/toddlers from touching hot surfaces.
- Check with your local hearth specialty dealer for safety screens and hearth guards to protect children from hot surfaces. These screens and guards must be fastened to the floor.
- Keep the packaging material out of reach of children and dispose of the material in a safe manner. As with all plastic bags, these are not toys and should be kept away from children and infants.
- Do not start a fire with chemicals or fluids such as gasoline, engine oil, etc.



**! WARNING**

- Your appliance requires periodic maintenance and cleaning. Failure to maintain your appliance may lead to smoke spillage in your home.
- Ashes must be disposed in a metal container with a tight lid and placed on a non-combustible surface well away from the home or structure until completely cool.
- Ensure clearances to combustibles are maintained when building a mantel or shelves above the appliance. Elevated temperatures on the wall or in the air above the appliance can cause melting, discolouration or damage to decorations, a TV or other electronic components.

**! WARNING:** This product can expose you to chemicals including lead and lead compounds, which are known to the State of California to cause cancer, and chemicals including carbon monoxide, which are known to the State of California to cause birth defects or other reproductive harm. For more information, go to [www.P65Warnings.ca.gov](http://www.P65Warnings.ca.gov).

**For wood appliances:**

- Lower emissions generally result when burning air dried seasoned hardwoods, as compared to softwoods or too green or freshly cut hardwoods. Burning wet unseasoned wood can cause excessive creosote accumulation. When this is ignited it can cause a chimney fire that may result in a serious house fire.
- This appliance is designed to burn natural wood only. Do not burn trash or garbage, lawn clippings / waste, rubber, waste petroleum products, paints or paint thinners / solvents, plastic, materials containing asbestos, construction debris, railroad ties or treated wood, manure or animal remains, salt water driftwood or salted materials, unseasoned wood, coal, charcoal, coloured paper, gift wrapping, cardboard, plywood or particleboard. Burning these materials may result in release of toxic fumes or render the appliance ineffective and cause smoke.
- Burn wood directly on the firebricks. Do not elevate grate or otherwise raise the fire.
- Do not store wood within appliance installation clearances or within the space required for re-fueling and ash removal.
- If equipped, the catalyst must be installed and in good working order. It is recommended that the catalyst is inspected at least three times per heating season.

# table of contents

<b>1.0</b>	<b>general information</b>	<b>5</b>
1.1	dimensions (complete with cast surround)	5
1.2	specifications	5
1.3	general instructions	6
1.4	general information	6
1.5	E.P.A. compliance	7
1.6	rating plate information	7
<b>2.0</b>	<b>pre-installation preparation</b>	<b>8</b>
2.1	minimum clearance to combustibles	8
2.2	hearth extension / floor protection	9
<b>3.0</b>	<b>installation</b>	<b>10</b>
3.1	typical existing masonry	11
3.2	installing the EPI3-1	12
3.3	factory built fireplace	13
<b>4.0</b>	<b>finishing</b>	<b>14</b>
4.1	secondary air tubes	14
4.2	bricks and baffle installation	15
4.3	surround installation, traditional cast	16
4.4	surround installation, contemporary cast	17
<b>5.0</b>	<b>operation</b>	<b>18</b>
5.1	optimum burn method	19
5.2	air control	20
5.3	fire extinguishers / smoke & carbon monoxide detectors	20
5.4	fuel	21
5.5	lighting a fire	21
5.5.1	flash fire	21
5.5.2	extended fire	22
5.6	smoking	22
5.7	blower operation	23
<b>6.0</b>	<b>maintenance</b>	<b>24</b>
6.1	ash removal procedures	24
6.2	creosote formation and removal	25
6.3	runaway or chimney fire	25
6.4	chimney cleaning	26
6.5	door removal	26
6.6	latch block mechanism replacement	27
6.7	door glass replacement	28
6.8	care of glass	29
6.9	care of plated parts	29
6.10	blower service or replacement	30
6.11	wood	31
<b>7.0</b>	<b>replacement parts</b>	<b>32</b>
7.1	EPI3C-1 overview	33
7.2	EPI3C-1 door assembly	34
7.3	EPI3T-1 overview	35
7.4	EPI3T-1 door assembly	36
7.5	EPI3C-1/T blower assembly	37
<b>8.0</b>	<b>troubleshooting</b>	<b>38</b>
<b>9.0</b>	<b>warranty</b>	<b>39</b>

## note:

Changes, other than editorial, are denoted by a vertical line in the margin.



**NOTE:** The camera icon indicates video tutorials are available as additional reference. Visit <http://mynapoleon.napoleonproducts.com/download/index/44/1>

1.1 dimensions (complete with cast surround)

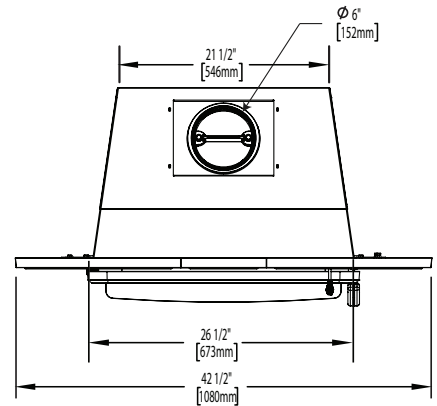
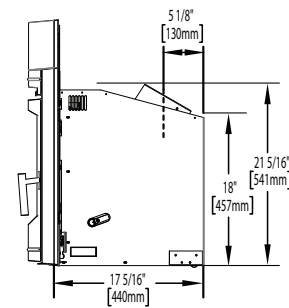
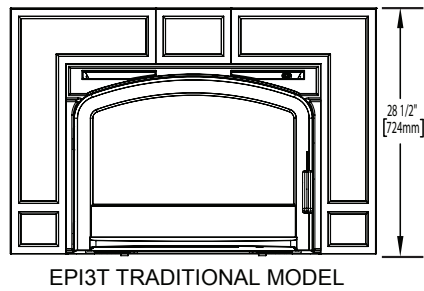
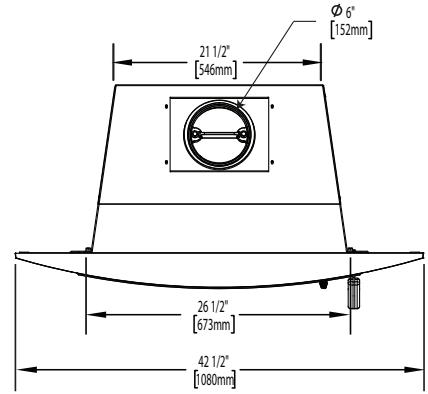
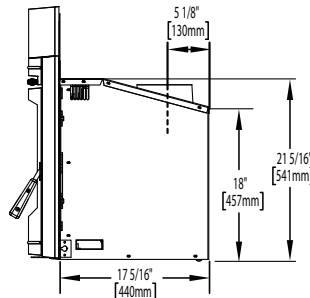
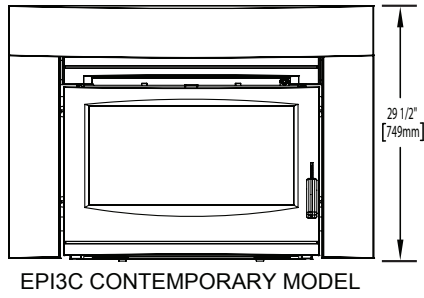

1.2 specifications

Specifications	EPI3-1
CHAMBER (D.W.H)	13 3/4" x 20 7/8" x 11 1/2" (349.3mm) x (530.3mm) x (292.1mm)
CAPACITY	1.8 ft <sup>3</sup> (0.05 m <sup>3</sup> )
APPROX. AREA HEATED**	1500 ft <sup>2</sup> (139.4 m <sup>2</sup> )
MAXIMUM HEAT OUTPUT***	55,000 BTU/Hr
HEAT OUTPUT*	11,000 - 28,000 BTU/Hr
DURATION LOW FIRE**	8 Hours
WEIGHT COMPLETE	400 lbs (181.4 kg)
WEIGHT OF BRICKS	80 lbs (36.3 kg)
WEIGHT WITHOUT CAST SURROUND (COMPLETE WITH DOOR) AND BRICKS	250 lbs (113.4 kg)

\* As tested using test method 28

\*\* Figures will vary considerably with individual conditions.

\*\*\* Wolf Steel Ltd. estimated realistic BTU/hr with cordwood logs and regular refueling.

# general information

## 1.3 general instructions

- Before beginning your installation, consult with your local building code agency or fire officials and insurance representative to ensure compliance.
- Non-toxic smoke will be emitted during the paint curing process to help dissipate the smoke open a window near the appliance.
- Remove any dust or debris off the top of the appliance before firing the appliance as the paint will become soft as the appliance heats up and will harden as the appliance cures. To cure the paint on your appliance, burn your appliance moderately hot during the first few fires.
- To keep the gasket from sticking to the appliance as the paint is curing, periodically open the door every 5-10 minutes.
- For the first two weeks, use generous amounts of fuel and burn the appliance with the damper wide open for an hour as the appliance goes through a process of eliminating moisture in the steel and firebricks. The initial heat output will be reduced while the moisture is being drawn from the appliance and it will be necessary to build several hot fires to remove this moisture.
- **DURING THIS PROCESS DO NOT OVERFIRE THE APPLIANCE. REDUCE THE AMOUNT OF AIR COMING INTO THE APPLIANCE IF THE APPLIANCE OR CHIMNEY BECOMES RED.**

## 1.4 general information

This appliance was specifically designed to meet the U.S. EPA 2020 particulate emission standards and has been extensively tested in Canadian and US laboratories to be efficient, simple, and trouble free.

The appliance uses clean-burning technology found in all Napoleon EPA certified stoves equipped with a heat circulating blower. External modifications have been made to allow its installation as a “functional insert” with a heat circulating blower system, as well as a means of enclosing the solid fuel burning fireplace cavity for greater heating efficiency.

The appliance must only be installed into a solid fuel burning fireplace that is at least 18” (45.7cm) deep, 27” (68.6cm) wide, and 22” (55.9cm) high with an approved lined chimney at least 15’ (4.6m) high and a hearth at least 18” (45.7cm) wide for Canada and 16” (40.6cm) wide for USA. This minimum recess can only be achieved if the opening height is sufficient enough to allow the connector to fit under the non-combustible facing. The appliance and chimney must be constructed in accordance with all national and local building code standards.

The chimney vent system used on this wood burning appliance should be designed with the least amount of restriction possible to enable the flow of exhaust products. Chimney vent systems that are too short or too long can also have an adverse affect on the flow of exhaust.

The wood burning appliance and chimney vent system require a sufficient supply of combustion air, not only to support the combustion in the combustion chamber, but to replace the outbound exhaust.

Secondary air from the side intake openings travels up to the secondary air housing, and then to the manifold located across the top. Finally, it flows out laterally to oxidize the gases below the smoke exit.

The combustion chamber is lined with high temperature refractory firebricks on the sides, back, and bottom. A fibre baffle on top helps maintain a high temperature in the combustion chamber so that gases mixing with the preheated air from the secondary air manifold tubes are easily ignited and burned.

There are many other appliances in the home competing with the appliance for air, such as kitchen range hoods, forced air heating devices, and bathroom exhaust fans. Therefore, in order to avoid fire hazards and/or injuries, be sure to provide sufficient combustion air to the appliance.

Expansion / contraction noises during heating up and cooling down cycles are normal and to be expected.

After extended periods of non-operation (i.e. vacation, warm weather season, etc.), the appliance may emit a slight odour for a few hours as a result of dust particles in the firebox burning off. If this happens, open a window to sufficiently ventilate the room.

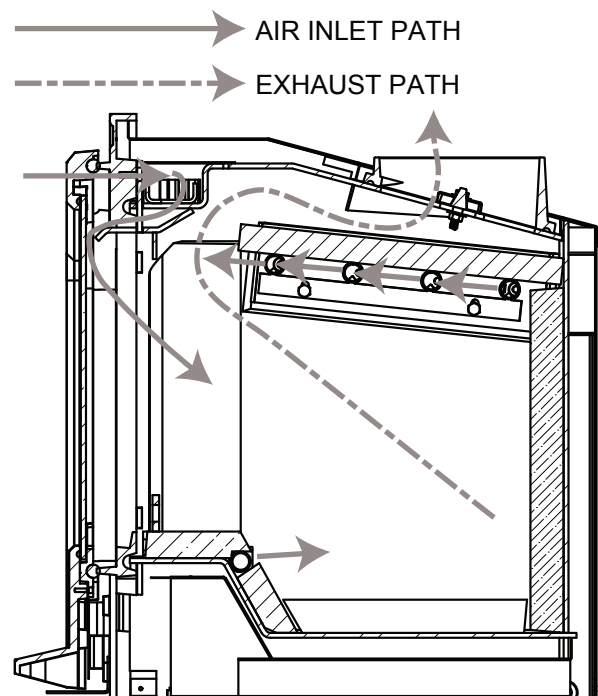

### 1.5 E.P.A. compliance

Model EPI3-1 meets the 2020 U.S. Environmental Protection Agency (E.P.A.) particulate emission standards using cordwood, 40 CFR Part 60, Subpart AAA. This appliance has been tested by Services PolyTests Inc. and listed by CSA Group to standards: ULC-S628, UL1482.

If the appliance begins smoking, open a door or window, or supply the appliance with combustion air in some other way.



We suggest that our woodburning hearth products be installed and serviced by professionals who are certified in the U.S. by the National Fireplace Institute® (NFI) as NFI Woodburning Specialists or who are certified in Canada by Wood Energy Technical Training (WETT).



### 1.6 rating plate information



Tested & Listed by  
OMNI Test Laboratories, Inc.  
415-S-11-2

**WOLF STEEL LTD.**  
24 NAPOLEON ROAD, BARRIE, ON  
L4M 0G8 CANADA

**NAC**  
214 BAYVIEW DRIVE, BARRIE, ON  
L4N 4Y8 CANADA

**WOLF STEEL USA**  
103 MILLER DRIVE  
CRITTENDEN, KY 41030-7560

**NAC GUANGZHOU P.R.C.**  
NO.69 HEFENG ROAD,  
GUANGZHOU, CHINA

**EPI3, LISTED SOLID FUEL BURNING FIREPLACE INSERT. TESTED TO ULC S628-93 / UL 1482-2011**

**WARNING:** RISK OF SMOKE SPILLAGE. OPERATE ONLY WITH DOOR FULLY CLOSED. REPLACE GLASS ONLY WITH THE CERAMIC GLASS. DO NOT OVERFIRE. IF HEATER OR CHIMNEY CONNECTORS GLOW, YOU ARE OVERFIRING. INSPECT AND CLEAN CHIMNEY FREQUENTLY UNDER CERTAIN CONDITIONS OF USE. CREOSOTE BUILD UP MAY OCCUR RAPIDLY.

**BLOWER KIT:** 115V, 60HZ, 1.5AMP. ROUTE CORD AWAY FROM UNIT.

**DANGER:** RISK OF ELECTRICAL SHOCK. DISCONNECT POWER BEFORE SERVICING UNIT.

**CHIMNEY CONNECTOR:** 6" (152mm) DO NOT CONNECT THIS UNIT TO A CHIMNEY FLUE SERVING ANOTHER APPLIANCE.

**FUEL:** FOR USE WITH SOLID WOOD FUEL ONLY. DO NOT USE GRATE OR ELEVATE FIRE. BUILT WOOD FIRE DIRECTLY ON HEARTH.

INSTALL AND USE ONLY IN ACCORDANCE WITH THE MANUFACTURER'S INSTALLATION AND OPERATION INSTRUCTIONS. INSTALL AND USE ONLY IN MASONRY FIREPLACE OR FACTORY BUILT FIREPLACE. CONTACT LOCAL BUILDING OR FIRE OFFICIALS ABOUT RESTRICTIONS AND INSTALLATION INSPECTION IN YOUR AREA.

**HEARTH EXTENSION/FLOOR PROTECTION:** MUST BE NON COMBUSTIBLE AND HAVE A MINIMUM THICKNESS OF 0.5" WITH A THERMAL CONDUCTIVITY FACTOR (K) 0.84 AND RESISTANCE VALUE (R) 0.59.

THIS WOOD APPLIANCE NEEDS PERIODIC INSPECTION AND REPAIR FOR PROPER OPERATION. CONSULT THE OWNER'S MANUAL FOR FURTHER INFORMATION. IT IS AGAINST UNITED STATES FEDERAL REGULATIONS TO OPERATE THIS WOOD APPLIANCE IN A MANNER INCONSISTENT WITH THE OPERATING INSTRUCTIONS IN THE OWNER'S MANUAL.

**U.S. ENVIRONMENTAL PROTECTION AGENCY Certified to comply with 2015 particulate emissions standards. Not approved for sale after May 15, 2020 40 CFR part 60, Subpart AAA, 2.8 Grams Per Hour / 2015 Cord Wood**

**CAUTION:** HOT WHILE IN OPERATION. DO NOT TOUCH. KEEP CHILDREN AND CLOTHING AND FURNITURE AWAY. CONTACT MAY CAUSE SKIN BURNS.

MANUFACTURE DATE:  
YEAR:  2016  2017  2018  2019  2020  
MONTH:  1  2  3  4  5  6  7  8  9  10  11  12

**Pour le français, l'étiquette arrière.**

INSTALLER SUR UN ÂTRE DE MATÉRIEL INCOMBUSTIBLE SURÉLEVÉ (F) 1.5 POUCES / 38MM DESSUS DU PLANCHER COMBUSTIBLE ADJACENT. LE PLANCHER COMBUSTIBLE DOIT ÊTRE PROTÉGÉ PAR LE MATÉRIEL INCOMBUSTIBLE QUI S'ÉTENDRE (E) 18 IN / 457MM (ÉTATS-UNIS) 18 IN / 457MM (CAN) EN AVANT ET (C) 8 IN / 203MM LES CÔTÉS DE LA PORTE. POUR DE PLUS AMPLES RENSEIGNEMENTS SUR LE MANTEAU, CONSULTEZ LE MANUEL D'INSTRUCTIONS.

**DÉGAGEMENTS AUX MATÉRIEL COMBUSTIBLES:**

A	ADJACENT SIDEWALL	A) 12"/305mm
B	MANTLE	B) 16"/406mm
C	TOP FACING	C) 16"/406mm
D	SIDE FACING	D) 6"/152mm

**OTL US logo**

Tested & Listed by  
OMNI Test Laboratories, Inc.  
415-S-11-2

**AVERTISSEMENT:** RISQUE D'ÉCHAPPEMENT DE FUMÉE. TENIR LA PORTE FERMÉE LORSQUE LE POÊLE FONCTIONNE. EMPLACEZ LA VITRE PAR UNE VITRE EN CÉRAMIQUE SEULEMENT. NE SURCHAUFFEZ PAS L'APPAREIL. SI L'APPAREIL OU LES RACCORDS ROUGEONT, L'APPAREIL SURCHAUFFE. INSPECTEZ ET NETTOYEZ LA CHEMINÉE FREQUENTEMENT. DANS CERTAINES CONDITIONS, DES DÉPÔTS DE CRÉOSOTE PEUVENT SE FORMER RAPIDEMENT.

**ÉPI3, Foyer encastré à combustible solide homologué. Testé selon les normes ULC S628-93 / UL 1482-2011**

**AVERTISSEMENT:** RISQUE DE SECOURS ÉLECTRIQUE. DÉBRANCHEZ AVANT DE PROCÉDER À L'ENTRETIEN.

**CRÉOSOTE DE LA CHEMINÉE:** 6" (152mm) NE PAS RACCORDER À LA CHEMINÉE D'UN AUTRE APPAREIL.

**COMBUSTIBLE:** POUR USAGE AVEC LE BOIS CHENET OU SURÉLEVÉ PAS. S'ÉCHAUFFEMENT. N'UTILISEZ PAS DE LE BOIS -PRÉPAREZ LE FEU DIRECTEMENT SUR L'ÂTRE.

**DANGER:** RISQUE DE SECOURS ÉLECTRIQUE LOIN DE L'APPAREIL. DÉBRANCHEZ AVANT DE PROCÉDER À L'ENTRETIEN.

APPELÉZ VOTRE INSPECTEUR DE BÂTIMENT LOCAL DÉPARTEMENT D'INCENDIE LOCAL POUR LES CODES LOCAUX ET POUR INSPECTER VOTRE INSTALLATION ET FOYER.

**PROTECTION DE PLANCHER:** DOIT ÊTRE INCOMBUSTIBLE ET AVOIR UNE ÉPAISSEUR MINIMALE DE 0.5" AVEC UN COEFFICIENT DE CONDUCTIVITÉ THERMIQUE (K) DE 0.84 ET UN COEFFICIENT DE RÉSISTANCE THERMIQUE (R) DE 0.59.

DATE DE FABRICATION:  
YEAR:  2016  2017  2018  2019  2020  
MONTH:  1  2  3  4  5  6  7  8  9  10  11  12

**ATTENTION:** QUAND L'APPAREIL FONCTIONNE, LA SURFACE DEVIENT CHAUDE. NE PAS TOUCHER. TENIR LES ENFANTS, LES VÊTEMENTS ET LES MEUBLES À L'ÉCAR. LE CONTACT PEUT CAUSER DES BRÛLURES À LA PEAU.

CET APPAREIL AU BOIS DOIT FAIRE L'OBJET D'UNE INSPECTION ET D'UN ENTRETIEN PÉRIODIQUES POUR UN FONCTIONNEMENT ADEQUAT. CONSULTEZ LE MANUEL D'INSTRUCTIONS POUR PLUS D'INFORMATION. LES RÉGLEMENTS FÉDÉRAUX DE L'ÉTATS-UNIS INTERDISSENT D'UTILISER CET APPAREIL DE CHAUFFAGE D'UNE MANIÈRE ALLANT À L'ENCONTRE DES INSTRUCTIONS DE FONCTIONNEMENT CONTENUES DANS CE MANUEL.

**U.S. Environmental Protection Agency: Certified conforme à la norme d'émission de particules de 2015. Non approuvé pour la vente après le 15 mai, 2020. 40 CFR Part 60, Subpart AAA, 2.8 Grammes par heure**

**Pour la date et le numéro de série, voir le revers.**

**For English see Reverse**

A	CÔTÉ	A) 12"/305mm
B	DESSUS	B) 16"/406mm
C	TABLETTE	C) 16"/406mm
D	MUR LATÉRAL	D) 6"/152mm

This illustration is for reference only. Refer to the rating plate on the appliance for accurate information. For the French, remove the rating plate, flip it over, and re-attach.

**note:**  
The rating plate must remain with the appliance at all times. It must not be removed.

## 2.0 pre-installation preparation

Clean all ashes from the inside of the existing appliance opening. Ensure the chimney and appliance are free of cracks, loose mortar, creosote deposits, blockages, or other signs of deterioration. If necessary, have repair work done by a qualified professional before installing the appliance.

**Do NOT remove bricks or mortar from the appliance.** In case of an outside air inlet or ash dump, fill with fiberglass insulation. Adhere to minimum clearances as illustrated.

### 2.1 minimum clearance to combustibles

MINIMUM CLEARANCES		
<b>A</b>	Sidewall	12" (30.5cm)
<b>B</b>	Mantel	16" (40.6cm) 12" (30.5cm) Projection
<b>C</b>	Top facing	16" (40.6cm)
<b>D</b>	Side facing	6" (152mm)
<b>E</b>	Hearth (front)	Canada 18" (45.7cm) USA 16" (40.6cm)
<b>F</b>	Hearth (side)	8" (203mm)
MINIMUM APPLIANCE OPENING		
<b>G</b>	Width (rear)	23" (58.4cm)
<b>H</b>	Width (front)	28" (71.1cm)
<b>I</b>	Height (front)	22" (55.9cm)
<b>J</b>	Height (rear)	19" (48.3cm)
<b>K</b>	Depth	18" (45.7cm)
<b>L</b>	Hearth depth	Canada 22" (55.8cm) USA 20" (50.8cm)
<b>M</b>	Hearth width	46" (116.8cm)
<b>N</b>	Facing width	54 1/2" (138.4cm)
<b>O</b>	Facing height	Contemporary 45 1/2" (115.5cm) Traditional 44 1/2" (113 cm)
<b>P</b>	Mantel	Contemporary 45 1/2" (115.5cm) Traditional 44 1/2" (113cm)
<b>Q</b>	Height of top surface	Contemporary 29 1/2" (74.9cm) Traditional 28 1/2" (72.3cm)
<b>R</b>	Side facing	13 1/4" (33.6cm)
<b>S</b>	Hearth (side)	9" (22.8cm)
<b>T</b>	Sidewall	13" (33cm)

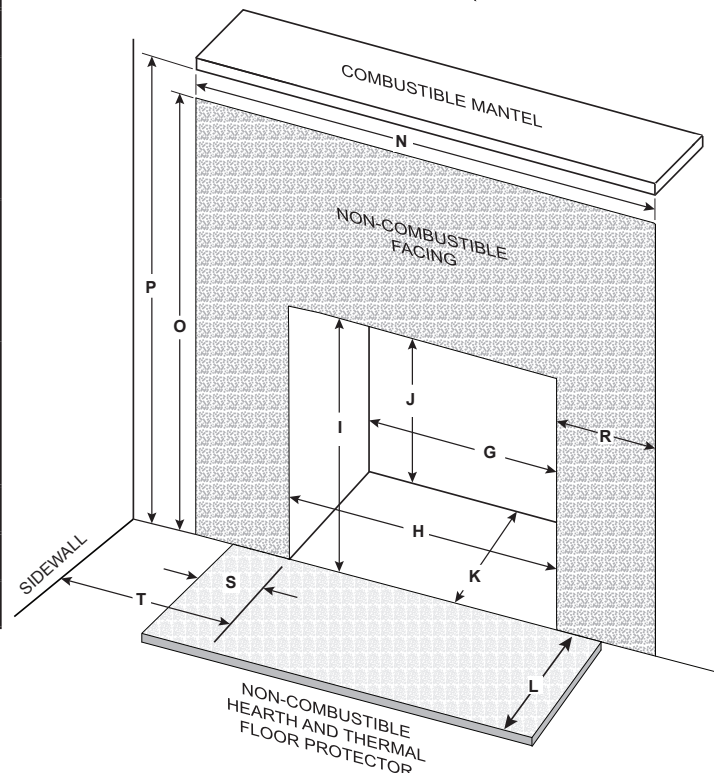
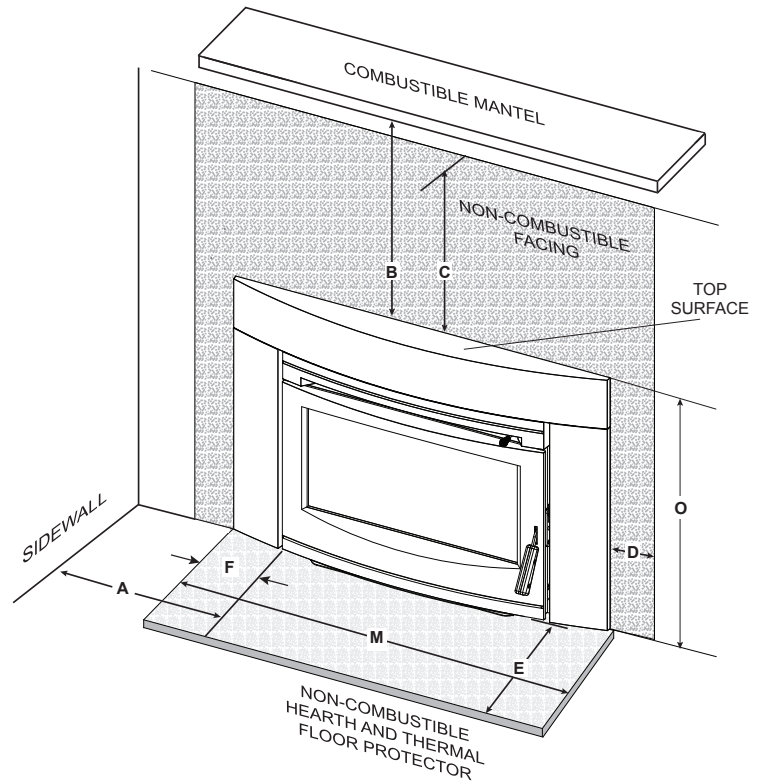

## 2.2 hearth extension / floor protection

Hearth extensions / floor protection must be made of non-combustible materials. They must meet the following specifications:

- Minimum extension to the front of the insert:
  - Canada: 18" (45.7cm)
  - USA: 16" (40.6cm)
- Minimum 8" (203mm) extension to the sides of the insert
- Minimum 0.5" (13mm) thickness
- Minimum (K\*) 0.84 thermal conductivity factor; and
- Minimum (R\*) 0.59 resistance value

\* See chart below for more information.

### CONVERTING MATERIAL SPECIFICATIONS TO R OR K VALUES

R = Thickness / K-Value

K = Thickness / R-Value

COMMON K and R VALUES CHART		
MATERIAL	K-VALUE	R-VALUE
	Per inch	Per inch
Micore 300	0.43	2.33
Wonderboard (cement board)	1.92	0.52
Common Brick	5.00	0.20
Cement Mortar	5.00	0.20
Ceramic Tile	12.50	0.08
Marble	11.00	0.09
Air Space (ventilated)	0.70	1.43
Sand and Gravel	1.70	0.59
Drywall (gypsum)	1.00	1.00
Rockwool or Fiberglass Batts	0.30	3.33

With K values, the lower value is a better insulator. With R values, the higher number is better.

#### K-Value Example:

A wood stove may call for thermal protection which has a K factor of 1 or less. A product such as Micore 300 Board from USG has a K-Value of approximately .43 per inch.

Therefore, a 1/2" (12.7mm) thickness of this board would have a K-Value of .86, which meets the requirement of our example stove.

#### R-Value Example:

This appliance calls for thermal protection with an R-Value of 0.59. This same board above is rated as having an R-Value of 2.33 for a 1" (25.4mm) thickness. Therefore, 1/2" (12.7mm) of the Micore 300 Board would have a R-value of 1.165, which meets the specifications for this appliance.



## 3.0 installation

### WARNING

- Wear gloves, protective footwear and safety glasses for protection.
- Carefully follow the instructions for assembly of the pipe and other parts needed to install the appliance. Failure to do so may result in a fire, especially if combustibles are too close to the appliance or chimney and air spacers are blocked, preventing the free movement of cooling air.
- Do not draw outside air from garage spaces. Exhaust products of gasoline engines are hazardous. Do not install outside air ducts such that the air may be drawn from attic spaces, basements or above the roofing where other heating appliances or fans and chimneys exhaust or utilize air. These precautions will reduce the possibility of appliance smoking or air flow reversal. The outside air inlet must remain clear of leaves, debris, ice and/or snow. It must be unrestricted while appliance is in use to prevent room air starvation which can cause smoke spillage and an inability to maintain a fire. Smoke spillage can also set off smoke alarms.
- Negative pressure within your home may inadvertently affect your appliance.
- To prevent contact with sagging or loose insulation, the appliance must not be installed against vapour barriers or exposed insulation. Localized overheating could occur and a fire could result.
- Do not use makeshift compromises during installation. Do not block or restrict air, grille or louvre openings. Do not add a hood.
- To prevent personal injury, keep hand tools in good condition, sharpen cutting edges and make sure tool handles are secure.
- Always maintain the minimum air space required in the enclosure to prevent fires.
- Check with local building officials for any permits required for installation of this appliance and notify your insurance company prior to proceeding.

It is extremely important that this appliance be installed according to the manufacturer's specifications, as well as local and national codes.

In Canada, the installation codes are:

- CSA B365 and
- CSA C22

In USA, the installation codes are:

- ANSI NFPA 70 and
- ANSI NFPA 211

**note:**

Before beginning installation, ensure chimney and liner are in good condition. They must be kept clean.

### 3.1 typical existing masonry

You can install your appliance using your existing masonry chimney. To do so, use the following guidelines. If you are using a masonry chimney, it is important that it be built in compliance with the specifications of the Building Code in your region. It must normally be lined with fire clay bricks, metal or clay tiles sealed together with fire cement. (Round flues are the most efficient).

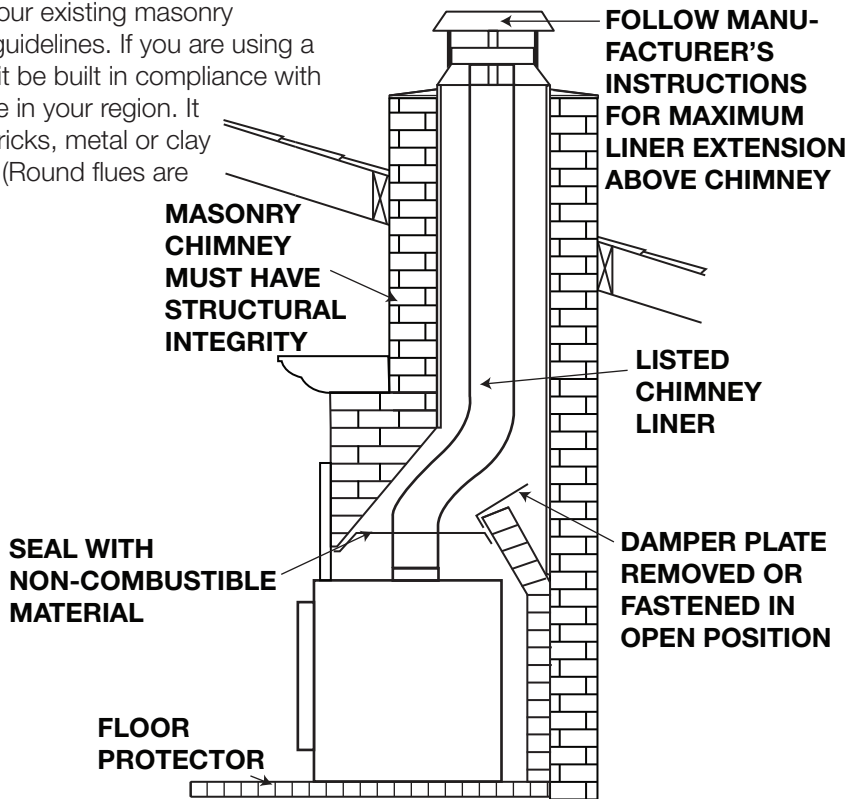

- A. Remove the fireplace damper or fasten it permanently open.

**note:**

It is recommended to follow the method of sealing off the damper area around the liner.

- B. Measure the throat of the fireplace and mark this shape on a piece of 24 gauge (0.6mm) sheet metal (flue cover). Cut a 6" (152.4mm) hole to lie directly below the fireplace flue opening. Allow 2" (50.8mm) of material on all sides (to act as flanges) and cut to these measurements. Bend down the flanges.

**TIP:** If inexperienced in doing this, make and test a cardboard pattern first.

Fasten this flue cover in position as high as possible. Using 2 masonry screws per side, insert them through the flanges into the fireplace.

- C. Permanently seal any openings between the fireplace masonry and the facing masonry.

**In Canada:** This fireplace insert must be installed with a continuous chimney liner of 6" (152.4mm) diameter extending from the fireplace insert to the top of the chimney. The chimney liner must conform to the Class 3 requirements of CAN/ULC-S635, Standard for Lining Systems for Existing Masonry or Factory-Built Chimneys and Vents, or CAN/ULC-S640, Standard for Lining Systems for New Masonry Chimneys. It must be installed as follows:

- A. Attach a stainless steel liner connector or elbow to the liner, and insert onto the flue collar.
- B. Fasten with 3 screws.
- C. Secure the top of the liner to the chimney cap using a liner support and chimney flashing.
- D. Cap the top of the chimney liner assembly using an approved rain cap.

# installation

**In USA:** Though not required, it is recommended that a chimney liner that is continuous from the insert to the top of the chimney be installed, particularly when the insert is installed in a basement. For this type of connection, use the “In Canada” installation instructions above.

If a continuous liner is not installed, a “direct flue connection” must be made. The direct flue connection requires a non-combustible connector that extends from the insert into the chimney flue liner. The installed flue cover must be sealed below the entry point of the connector to prevent dilution of combustion products in the chimney flue. This room heater must be connected to a code-approved masonry chimney with a flue liner. Cap the top of the chimney using an approved rain cap.

The installation requirements that follow **must** be observed when installing solid fuel burning inserts into factory-built fireplaces.

## 3.2 installing the EPI3-1



### A. flue collar orientation

Prior to installation, determine the type of orientation that works best with this appliance.

The flue collar's orientation can be vertical. It can also be a 30° backwards angle by rotating the flue collar 180° at the top of the appliance.

It is recommended to clean the chimney from the top downwards. This will ensure that the centre bar of the flue collar protects the inside baffle from any damages caused by the chimney brush. However, if cleaning must be done from inside the home, use a reciprocating metal cutting saw or hack saw to cut the centre bar inside the flue collar.

### B. installing a venting system

#### note:

It is recommended that the connector or flue liner be installed before continuing with the installation. See Figure 1 for venting system components.

1. Remove the front air tube to gain access to the fiber baffle, and then remove the fiber baffle.
2. Remove the iron flue collar from the appliance. Ensure gasket is in place and in good condition.
3. Drill 3 holes into the adapter pipe or flue liner, using the holes in the iron collar as a guide. Secure the adapter pipe (or flue liner) to the flue collar. Ensure the studs on the flue collar are properly aligned to their respective holes on the insert.
4. Repeat Step 3 to secure the flexible pipe to the pipe adaptor.
5. The finished height measurements from the hearth surface to the center bar of the flue collar should be 19" (482.6mm). See Figure 2 for details on the installation of the connector pipe or liner. This allows for an easy connection once the appliance is in place.

FIG. 1

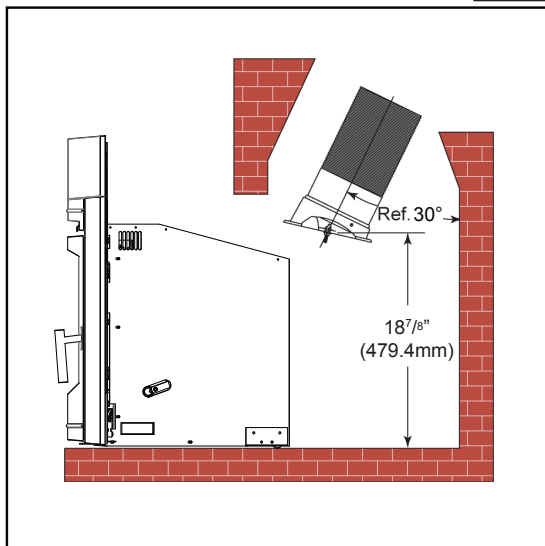
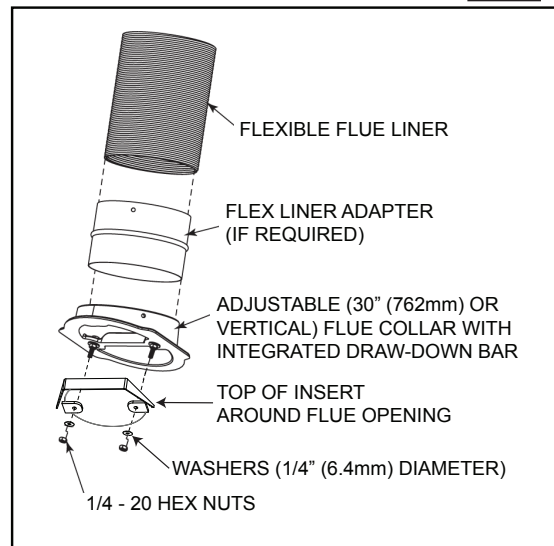

FIG. 2



### 3.3 factory built fireplace

The following installation requirements must be observed when installing solid fuel burning inserts into factory built fireplaces.

- A. The factory built fireplace must be listed per UL 127 or ULC S610.
- B. Clearances to any combustible material surrounding this insert as identified must be followed. These clearance requirements supersede any pre-existing facing material clearances listed for the factory built fireplace.
- C. Installation must include a full height listed chimney liner meeting HT requirements (2100°F/1149°C) as required in UL 1777 (U.S.) or ULC S635 (Canada). The liner must be securely attached to the insert flue collar and the chimney top.
- D. Means must be provided to prevent room air passage to the chimney cavity of the fireplace. This may be accomplished by sealing the damper area around the chimney liner, or sealing the appliance front.
- E. The air flow within and around the appliance shall not be altered by the installation of the insert (i.e. no louvres or cooling air inlet or outlet ports are blocked), unless specifically tested as such for each factory built fireplace manufacturer and model line.

**note:**

Using a louvered face plate (surround) complies with this requirement.

- F. Alteration of the appliance in any manner is not permitted with the following exceptions;
  - A. External trim pieces which do not affect the operation of the appliance may be removed providing they can be stored on or within the fireplace for reassembly if the insert is removed.
  - B. The chimney damper may be removed to install the chimney liner.
- G. Circulating air chambers (i.e. in a steel fireplace liner or metal heat circulator) shall not be blocked.
- H. Means must be provided for removal of the insert to clean the chimney flue.
- I. Inserts that project in front of the fireplace must be supplied with appropriate support means.
- J. A permanent metal warning label must be attached to the back of the fireplace stating that the fireplace must be restored to its original condition for safe use without the insert.

## 4.0 finishing

### 4.1 secondary air tubes

- A. Starting at the back with the shortest tube and working forward, install the secondary air tubes by first inserting the tube into the hole on the left side of the firebox and then into the corresponding hole on the right side. Next, align the notch with tab, and slide the tube all the way to the right (FIG 1).
- B. Insert the cotter pin to secure the tube in place (FIG 2).

**note:**

It is recommended to leave the front tube out until the fibre baffle has been installed.

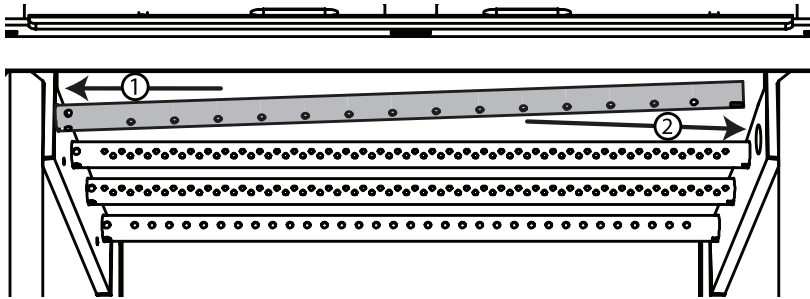
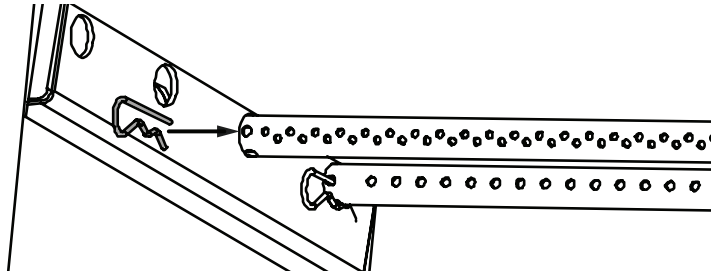
**FIG. 1****FIG. 2**

## 4.2 bricks and baffle installation

### ! WARNING

- Operation of the appliance without the baffles can result in excessive temperatures that could damage the appliance, chimney and the surrounding enclosure.

#### note:

Ensure the firebox insulation (W361-0189) is in good condition before proceeding. Replace if necessary.

- Install the 2 side bricks (W090-0191, W090-0192) against the sides of the firebox, secure using the retainers.
- Install the back brick (W090-0190) by sliding it under and behind the rear secondary air tubes. Secure with retainers.
- Install the 2 bottom bricks (W090-0193, W090-0194).
- Slide the front brick (W090-0196) into place in front of the bottom bricks, ensuring the angled edge sits flush with the bottom bricks.
- Install the front ledge brick (W090-0195), ensuring the notches line up with the fire grate slots.
- Place the baffle (W018-0133) on top of the secondary air tubes and slide it all the way to the rear of the firebox.

#### note:

Step F may require the front secondary air tube to be removed.

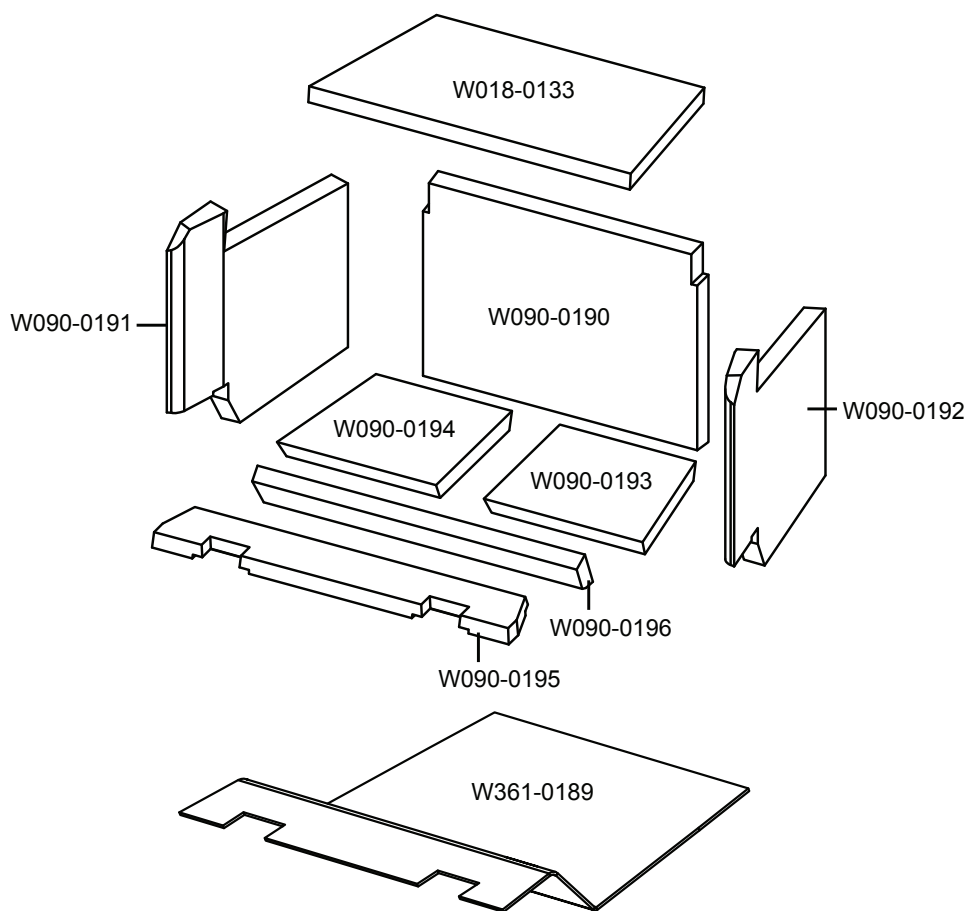



### 4.3 surround installation, traditional cast

- A. Place the 2 side castings and the centre casting face down on a protected surface and assemble as shown (FIG 1).
- B. Line up the casting holes with the casting bracket holes and secure in place using the screws. Secure the casting support to the casting bracket using the screws (FIG 1, A).
- C. Loosely secure the screws to the holes in the side casting (FIG 1, B). Repeat on the other side.
- D. Using screws, secure the 4 retaining brackets in place (FIG 2, C).
- E. Lift the casting, place the screws into the retaining brackets, and tighten fully (FIG 2, D).

#### note:

To ensure the joints are flush, adjustment may be necessary. To adjust the cast components, loosen the screws and then align the casting to desired position.

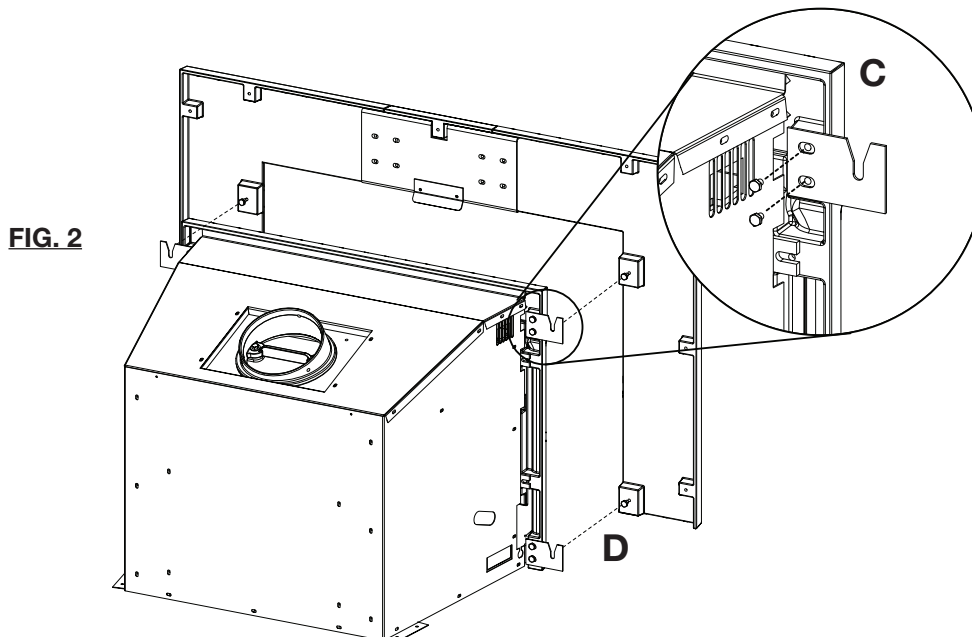
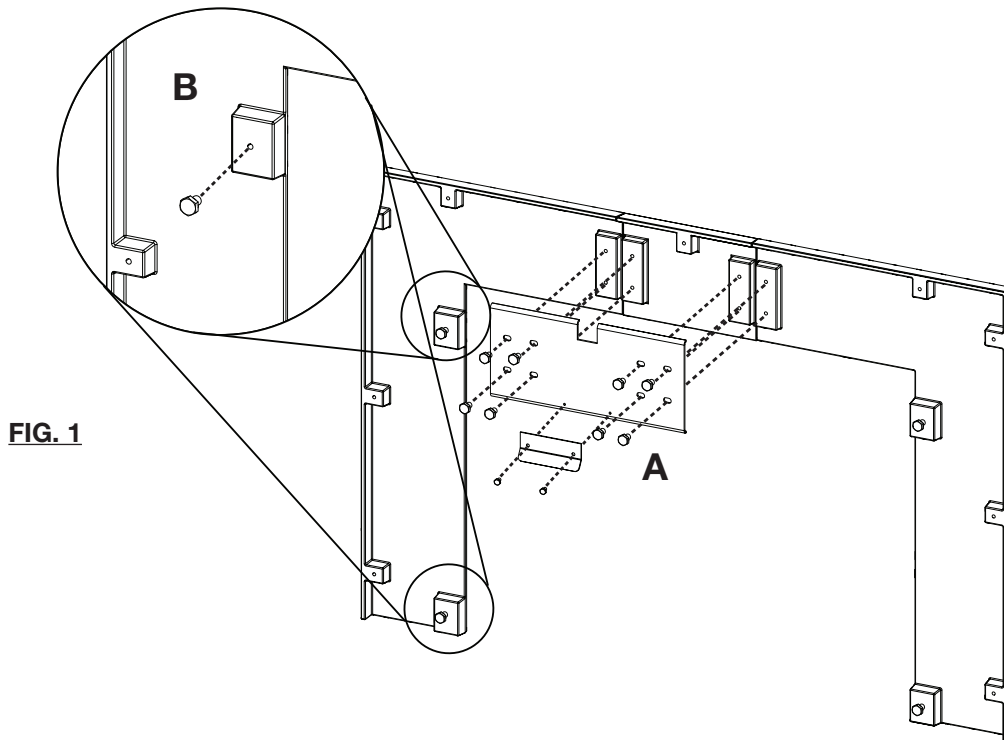

**4.4 surround installation, contemporary cast**

- A.** Line up the casting holes with the right retaining bracket holes and secure in place using the 1/4-20 hex-head screws. Repeat on the left side, using the left retaining bracket (FIG 1, A).
- B.** Thread the 1/4-20 round-head screws approximately half their length into the keyed bracket (FIG 1, B).
- C.** Place the casting pieces face down on a protected surface and assemble as shown (FIG 2).
- D.** Fasten the securing brackets using the screws (FIG 2, C).
- E.** Secure the corner brackets into place on both sides of the casting using the screws (FIG 2, D).
- F.** Lift the casting, place the keyed holes onto the 1/4-20 round head screws, and rest the casting into place (FIG 2). Adjust screws as necessary to stabilize.

**note:**

To ensure the joints are flush, adjustment may be necessary. To adjust the cast components, loosen the screws and then align the casting to desired position.

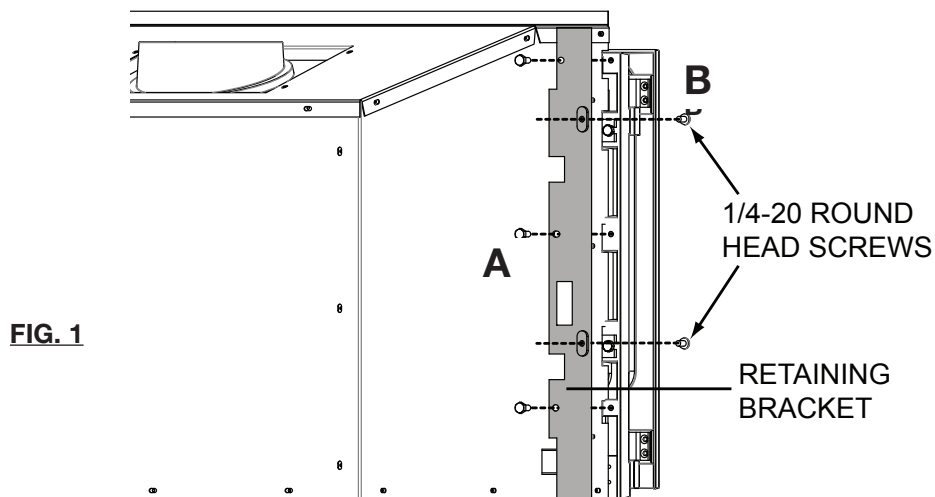

**FIG. 1**

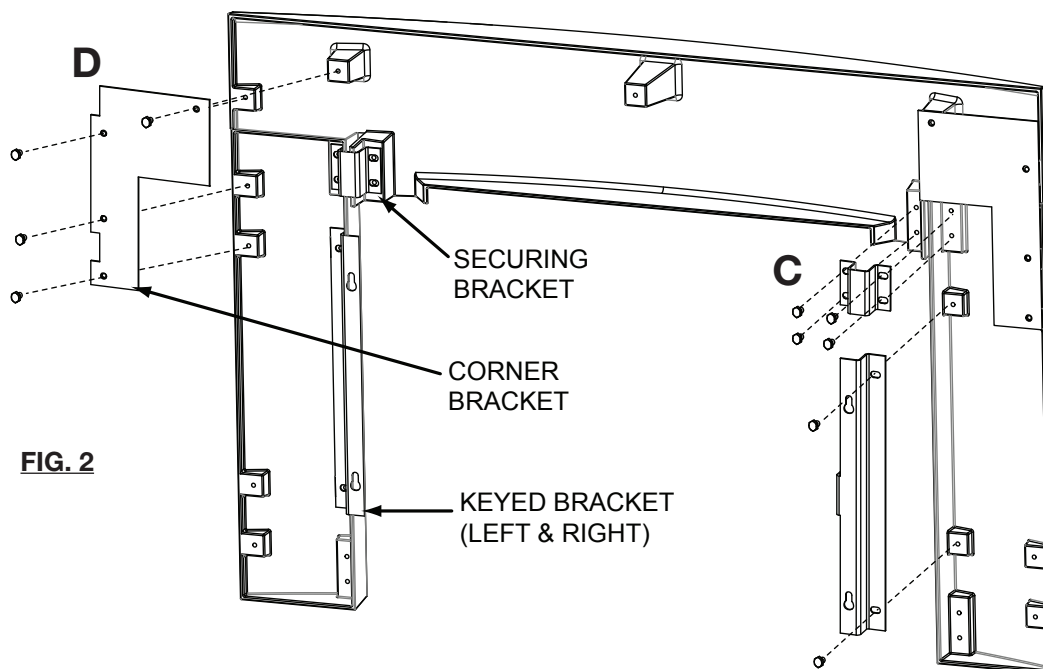

**FIG. 2**



## 5.0 operation

### WARNING

- Always operate this appliance with the door closed and latched except during startup and re-fueling. Always wear gloves to prevent injury. Do not leave the fire unattended when the door is unlatched as unstable wood could fall out of the fire chamber creating a fire hazard to your home.
- Never leave children unattended when there is a fire burning in the appliance.
- Never use gasoline, gasoline-type lantern fuel, kerosene, charcoal lighter fluid, or similar liquids to start or 'freshen up' a fire in this appliance. Keep all such liquids well away from the appliance while it is in use.
- Objects placed in front of the appliance should be kept a minimum of 48" (121.9cm) from the front face.
- Any modification of the appliance that has not been approved in writing by the testing authoring is considered breaching CSA B365 (Canada) and ANSI NFPA 211 (U.S.A.).
- Open air control (and damper when fitted) before opening firing door.
- Hot while in operation. Keep children, clothing, and furniture away. Contact may cause skin burns. Wear gloves to operate your appliance.
- Burning your appliance with the doors open or ajar creates a fire hazard that may result in a house and/or chimney fire.
- This wood appliance has a manufacturer-set minimum low burn rate that must not be altered. It is against federal regulations in the United States to alter this setting or otherwise operate this wood appliance in a manner inconsistent with operating instructions in this manual.

This Napoleon EPA listed product is designed with the most advanced technology. The appliance is extremely airtight.

#### note:

The first fire(s) in this appliance will be difficult to get and keep going with minimal heat being generated. This is a result of the moisture being driven out of the firebrick. During the break-in period (i.e. the first 2 or 3 fires), create only small fires using kindling, as this will allow the firebrick to cure.

**WARNING: Creating a brisk fire during the break-in period could result in fire hazards, including explosions. Use caution.**

Do not be alarmed if small hairline cracks develop in the firebrick. This is a normal occurrence and does not pose a safety hazard. The paint may also emit an odour for the first few fires as a result of the curing process. If this happens, open a window or door to ensure adequate ventilation.

#### **CREATING A BRISK FIRE (AFTER APPLIANCE HAS CURED)**

- Place loosely crumpled paper on the bottom of the appliance and cover with dry kindling.
- Open the air control fully by sliding it all the way to the left.
- Light the paper and leave the door slightly ajar (no more than 1" (25.4mm)) until all kindling is burning.

#### note:

To maintain a brisk fire, a hot coal bed must be established and sustained.

- Slowly add larger pieces of wood (i.e. 2x4" pieces). Lay them lengthwise in the hot coal bed with a shallow trench between, as this will allow air to flow into the trench and ignite the fuel.
- When the fire has reached its peak, begin adding medium-sized logs. When these logs have caught fire, carefully close the door.

#### note:

Closing the door too quickly after refuelling will reduce the firebox temperature and result in an unsatisfactory burn.

**TIP:** It is more efficient to burn medium-sized wood briskly and to refuel frequently than to burn large logs and refuel infrequently. Large logs create smouldering, inefficient fires that dirty the glass.

**note:**

As soon as the door is closed, a change will occur in the flame pattern. The flames will get smaller and lazier because less oxygen is getting into the combustion chamber. The flames, however, are more efficient. The flames will remain lazy but become larger again as soon as the firebricks have been heated thoroughly, and the chimney becomes heated and provides a good draft. At this point, the roaring fire that is visible when the door is opened is wastefully drawing heated room air up the chimney. Always operate with the door fully closed once the medium-sized logs have caught fire. Operating the appliance with the door open for extended periods of time may result in damages to the appliance.

- E. Begin adding larger pieces of wood, as the appliance can operate normally at this point.
- F. The firebox can be safely filled with wood to the top of the door opening if a 1/4" (6.4mm) space to secondary air tubes is maintained.

**note:**

Once the appliance is entirely hot, it will burn very efficiently with little smoke from the chimney. There will be a bed of orange coals in the firebox and secondary flames flickering just below the top baffles.

Refer to "troubleshooting" section if encountering problems with operation.

## 5.1 optimum burn method

- A. Maintain a hot, glowing, red coal bed that is 2" (50.8mm) deep.
- B. Burn dry seasoned wood.
  - TIP:** To ensure the glass door remains clean, wood should have less than 20% moisture content.
- C. A minimal trace of smoke coming from the chimney is acceptable when the appliance is burning as intended.
- D. Inspect and replace all necessary components (i.e. gaskets, manifolds, glass, etc.) as they may affect the appliance's overall performance.
- E. Adjust the air control for adequate draft. This will control the burn rate and temperature of the appliance.

Refer to "operation" and "maintenance" sections for detailed information.

**! WARNING**

- This wood appliance has a manufacturer-set minimum low burn rate that must not be altered. It is against federal regulations in the United States to alter this setting or otherwise operate this wood appliance in a manner inconsistent with operating instructions in this manual.

Draft is the force which moves air from the firebox up through the chimney. The amount of draft in the chimney depends on the length and diameter of the chimney, local geography, nearby obstructions, etc.

Adjusting the air control all the way to the right reduces the temperature. The draft can be adjusted from low to high by moving the handle from right to left. Inadequate draft may cause back-puffing into the room through the appliance and chimney connector points and may cause plugging of the chimney.

Too much draft may cause the appliance to become too hot. Glowing red appliance parts or chimney connectors, as well as uncontrollable burns, can lead to chimney fires or permanent damage to the appliance.

Do not operate the appliance for longer than 30 minutes with the air control on "HIGH" (fully open).

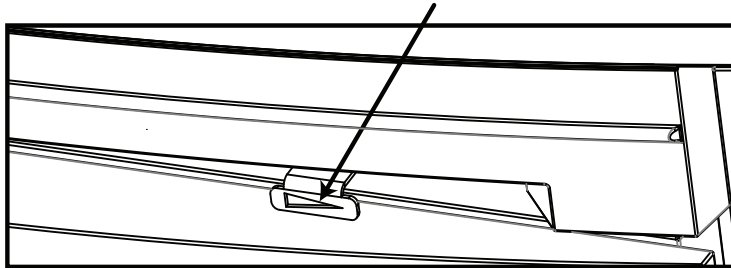
**AIR CONTROL****5.3 fire extinguishers / smoke & carbon monoxide detectors****note:**

Always check that smoke and CO detectors are working properly.

All homes with a solid fuel burning appliance should have at least one fire extinguisher in a central location, known to all, at least one smoke detector and carbon monoxide (CO) detector in the room containing the appliance. If the smoke detector sounds an alarm, correct the cause but do not deactivate or relocate the smoke detector. If the carbon monoxide detector sounds an alarm, immediately vent the area, evacuate and call your local fire department.

## 5.4 fuel

### ! WARNING

- Do not store fuel within the clearance to combustibles, or in the space required for re-fueling and ash removal.
- Burning wet, unseasoned wood can cause excessive creosote accumulation. When ignited, it can cause a chimney fire that may result in a serious house fire.

When the appliance is hot, load it to the top of the door opening while maintaining a 1/4" (6.4mm) space to secondary air tubes, and burn at a medium-low setting. The bricks will be nearly all white and the glass mostly clear. The whiteness of the bricks and the cleanliness of the glass are good indicators of operating efficiency. Not enough heat is produced when only 1 or 2 pieces of wood are burned or the wood is not burned completely. A minimum of 3 pieces are needed to create a bed of coals that sustains fire.

#### note:

When loading the appliance, keep fuel away from the glass. This prevents it from falling out when the door is open, which could cause fire hazards and/or injuries.

Loosely stacked wood burns quicker than a tightly packed load. Wood burns in cycles rather than in a steady state. Therefore, it is best to plan these cycles around household routines to ensure enough coals are left to start the next load. In the evening, load the appliance at least 30 minutes before bed to ensure a fire that is hot enough to close the draft control for an overnight burn.

Burn only dry seasoned wood with less than 20% moisture content. It produces more heat and less soot or creosote. Do not burn ocean beach wood, as its salt content can produce acids that corrode metal. When refueling, open the door slowly to prevent smoke spillage. Use a pair of long gloves when feeding the fire, and keep a small steel shovel nearby to use as a poker and to remove ashes. Do not store the wood within 3 feet (1m) of the appliance.

## 5.5 lighting a fire

#### note:

During initial startup, appliance may smoke, especially if there is poor draft. To prevent the appliance from smoking, open the door approximately 1 to 2 inches (25mm to 51mm).

### 5.5.1 flash fire

A flash fire is a small fire burned quickly when you don't need much heat. After your kindling has "caught", load at least 3 pieces of wood, stacked loosely. Burn with the draft control fully open or closed only slightly.

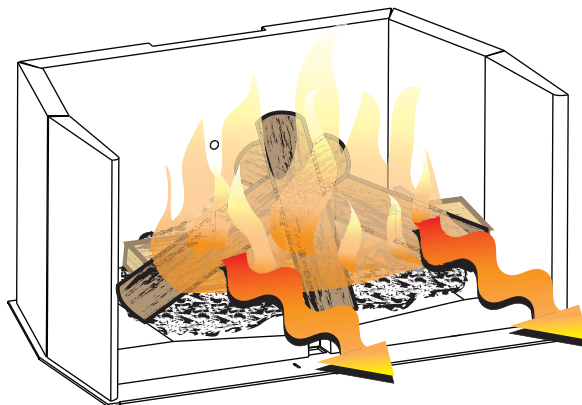

## operation

### 5.5.2 extended fire

Load your larger pieces of wood so they are tightly packed, close enough to prevent the flames from penetrating it completely. After approximately 30 minutes, depending on the size of the load, close the draft control completely making sure that the fire is not extinguished.

#### **DO NOT OVERFIRE THE APPLIANCE!**

##### **Overfiring can occur by:**

- A.** Burning large amounts of smaller wood pieces such as furniture scraps, skids or treated wood;
- B.** Vigorously burning large loads of wood with the draft control on "HIGH" (fully open) for long periods of time (one or two hours).
- C.** Operating the appliance with the ash dump door blocked open or a poor gasket seal on the main door.

### 5.6 smoking

A properly installed appliance should not smoke. If yours does, check the following:

- Has the chimney had time to get hot?
- Is the smoke passage blocked anywhere in the appliance, chimney connector or chimney?
- Is the room too airtight and the air intake not connected to the outside? Try with a window partly open.
- Is the smoke flow impeded by too long a horizontal pipe or too many bends?
- Is it a weak draft perhaps caused by a leaky chimney, a cold outside chimney, too large a diameter of a chimney, too short a chimney, or a chimney too close to trees or a higher roof?
- Is the moisture content of the wood greater than 20%?
- If equipped, has the catalyst bypass been closed or closed prematurely?

## 5.7 blower operation

### **! WARNING**

- Risk of fire and electrical shock.
- Turn off the electrical power before servicing the appliance.
- Use only Wolf Steel approved optional accessories and replacement parts with this appliance. Using non-listed accessories (blowers, doors, louvres, trims, etc.) could result in a safety hazard and will void the warranty and certification.
- Ensure that the blower's power cord is not in contact with any surface of the appliance to prevent electrical shock or fire damage. Do not run the power cord beneath the appliance.

Drywall dust will penetrate into the blower bearings, causing irreparable damage. Care must be taken to prevent drywall dust from coming into contact with the blower or its compartment. Any damage resulting from this condition is not covered by the warranty policy. Use of the blower increases the output of heat.

Keep the blower opening free from ash build-up.

This appliance is equipped with a micro (pressure) switch and thermally-activated switch. The micro switch shuts off the blower when the door is open. This helps prevent smoke from being blown into the room. The blower will only operate when the door is closed and the thermally activated switch reaches the appropriate temperature. This will take approximately 30 to 60 minutes, depending on the intensity of the fire.

### **HOW TO USE THE BLOWER**

1. Open the door and adjust the variable speed switch to desired speed.
2. It is necessary to depress the micro switch when making adjustments to the blower.

#### **note:**

For highest efficiency, do not operate the blower when the air control is set to its lowest setting. Furthermore, operate the blower on a slower speed when the air control is not more than 3/8" (9.5mm) open from its lowest setting, and operate on any speed when air control is on any other setting. When the appliance is cool, vacuum ash out from the blower area, for improved performance and an increased longevity.

#### **note:**

This blower has thermal overload protection. For optimal performance operate blower at all times, while the appliance is fired, except when the air control is set to its lowest setting.

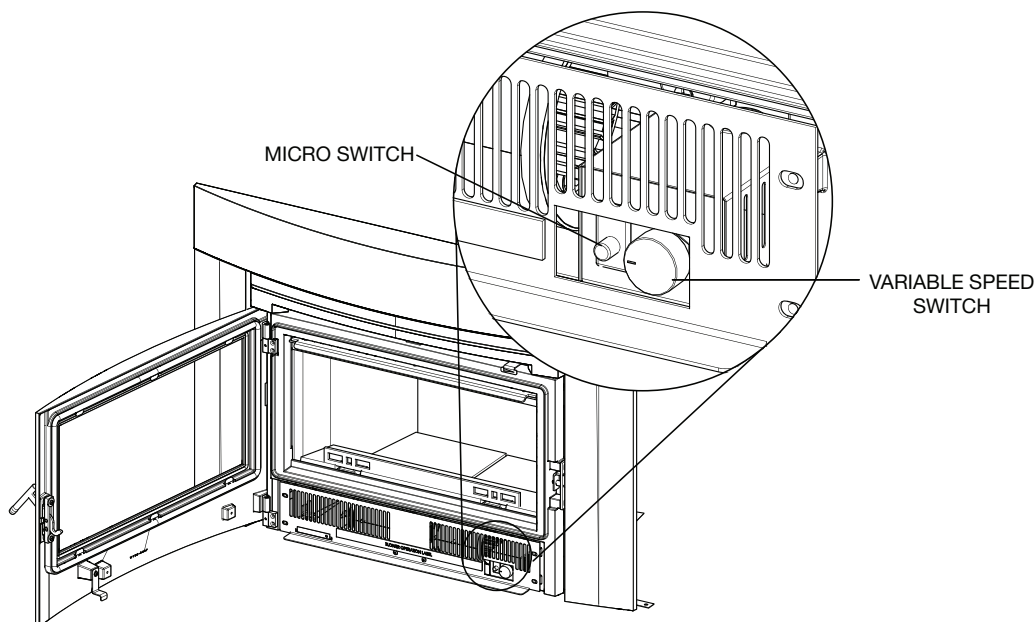

## 6.0 maintenance

### **!** WARNING

- Turn off the power before servicing the appliance.
- Appliance may be hot. Do not service until appliance has cooled.
- Do not use abrasive cleaners.

Check chimney and chimney connector weekly for creosote and soot buildup until a safe frequency for cleaning is established.

If accumulation is excessive, disconnect the appliance and clean both the chimney and the appliance. It is recommended to call a professional for this. Both chimney and appliance have to be cleaned at least once a year or as often as necessary.

Remove the baffle and clean above it once a year. Replace any broken bricks.

### 6.1 ash removal procedures

### **!** WARNING

- Improper disposal of ashes result in fires. Do not discard ashes in cardboard boxes, dump in backyards or store in garages.
- If using a vacuum to clean up ashes, be sure the ashes are entirely cooled. Using a vacuum to clean up warm ashes could cause a fire inside the vacuum.

A bed of ashes approximately 1" (25mm) deep should be left on the firebox bottom to help maintain a hot charcoal bed. When the fire has burned down and cooled, remove any excess ashes. To remove the ash, follow the directions below:

- A.** After the last coal has extinguished, let the appliance cool at least 2 hours.
- B.** Open the appliance doors.
- C.** Scoop the ash from the firebox into a metal container with a lid. Cover the container and move the container away from the appliance onto a suitable surface to ensure the ashes cool.
- D.** Dispose of the ashes.

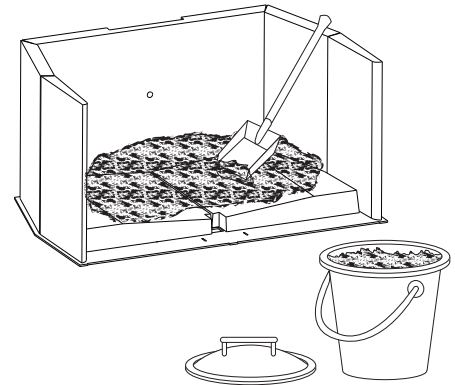

#### **note:**

Ashes should be placed in a metal container with a tight-fitting lid. The closed container of ashes should be placed on a non-combustible floor or on the ground, well away from all combustible materials, pending final disposal. If the ashes are disposed of by burial, in soil, or otherwise locally dispersed, they should be retained in the closed container until all cinders have thoroughly cooled.

## 6.2 creosote formation and removal

When wood is burned slowly, it produces tar and other organic vapors, which combine with expelled moisture to form creosote. The creosote vapors condense in the relatively cooler chimney flue or a slow-burning fire. As a result, creosote residue accumulates on the flue lining. When ignited, this creosote makes an extremely hot fire.

The chimney connector and chimney should be inspected at least once every two months during the heating season to determine if a creosote buildup has occurred.

If creosote has accumulated, it should be removed to reduce the risk of a chimney fire.

## 6.3 runaway or chimney fire

### **WARNING**

- A chimney fire can permanently damage your chimney system. This damage can only be repaired by replacing the damaged component parts. Chimney fires are not covered by the lifetime limited warranty.

#### **CAUSES:**

- Using incorrect fuel, or small fuel pieces which would normally be used as kindling.
- Creosote build up in chimney.
- Leaving the door ajar too long and creating extreme temperatures as the air rushes in the open door.
- If equipped, burning your appliance with the ash plug not securely seated.

#### **SOLUTIONS:**

- Do not burn treated, painted, artificial, paper or processed wood logs, coal, charcoal, coloured paper or cardboard.
- Have chimney regularly cleaned.
- Be careful not to over-fire the appliance by leaving the door open too long after initial start-up. A thermometer on the chimney connector and/or appliance top helps to indicate the appliance operating temperature.
- If equipped, always operate the appliance with the ash plug properly installed.

#### **IN CASE OF A CHIMNEY FIRE:**

- Close glass door and air control (and damper, when equipped).
- Have a well understood plan for evacuation and a place outside for everyone to meet. Prepare to evacuate to ensure everyone's safety.
- Call local fire department. Have a fire extinguisher handy. Contact local authorities for further information on how to handle a chimney fire.
- After the chimney fire is out, clean and inspect the chimney or chimney liner for stress and cracks prior to lighting another fire. Also check combustibles around the chimney and the roof.



# maintenance

## 6.4 chimney cleaning

Both the chimney and the appliance must be inspected and cleaned if necessary at least once a year. For serious wood burners, chimney cleaning must be done as needed to avoid chimney fires; the venting systems for controlled combustion appliances may need cleaning as often as once a month. These rates, however, depend on the burning habits of the individual operating the appliance. For example, it is possible to clog a solid fuel appliance chimney in a few days if slow, smoldering fires are burned and the chimney is cold.

### note:

Appliances burned consistently without hot fires may result in significant creosote accumulations in the chimney.

Certain items and considerations are important in chimney cleaning:

- Proper tools should be used, including a brush specifically designed for chimney cleaning.
- The chimney connector and dampers as well as the chimney should be cleaned.
- The appliance's firebox and baffle system should be cleaned if needed.
- The chimney should be inspected and repairs made if needed, preferably by a qualified chimney sweep or mason.



## 6.5 door removal

### ! WARNING

- Burning your appliance with the doors open or ajar creates a fire hazard that may result in a house and/or chimney fire.
- Do not strike or slam door.
- Never removed the door when the appliance is hot.

To remove door, remove the 2 screws from both top and bottom hinges (FIG. 1).

### note:

Due to the weight of the door, it is recommended that 2 people perform the door removal.

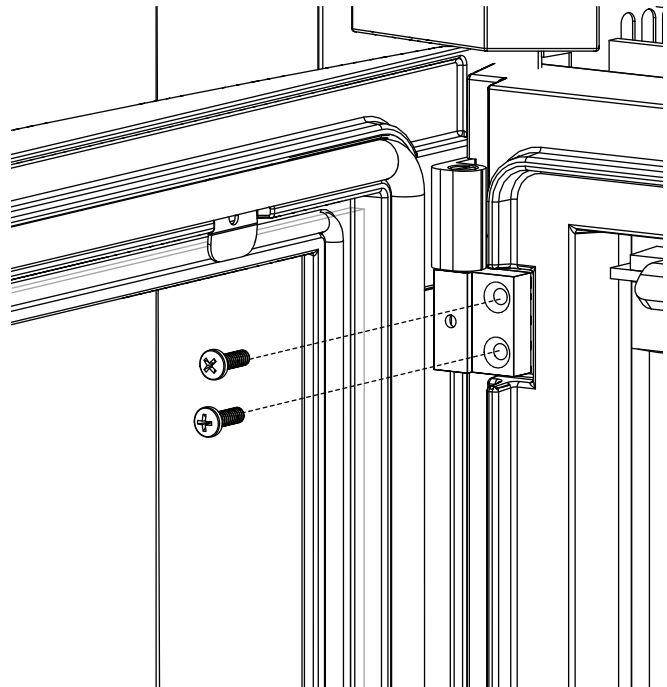

FIG. 1

6.6 latch block mechanism replacement

**! WARNING**

- Burning your appliance with the doors open or ajar creates a fire hazard that may result in a house and/or chimney fire.
- Do not strike or slam door.
- Never removed the door when the appliance is hot.

- Remove the 2 screws securing the latch block to the door.
- Pull the handle towards the inside of the door and remove the latch block components, then remove the latch block and handle support. Replace any damaged or worn components.
- To reinstall the handle support, align the top and bottom screw holes of the latch block to the top and bottom screw holes of the door (FIG 1).
- Loosely tighten the top screw and install the 2 pins (FIG 1).
- To install the spring, slip it into the bottom of the latch block and then install the screw. Apply a small amount of high temperature grease to the spring and pins prior to installation.

**TIP:** Compress the spring using a flat head screw driver, as this allows for easy installation of the screw (FIG 2).

**note:**

To ensure proper installation, the handle support should remain in an upwards position, and the handle support should engage smoothly with the firebox.

- OPTIONAL:** To permanently secure handle, apply clear RTV to the inside of the handle, slide it into place, and let cure for 24 hours.
- Adjust the latch block up or down, angling the handle support away from the door in the closed position.

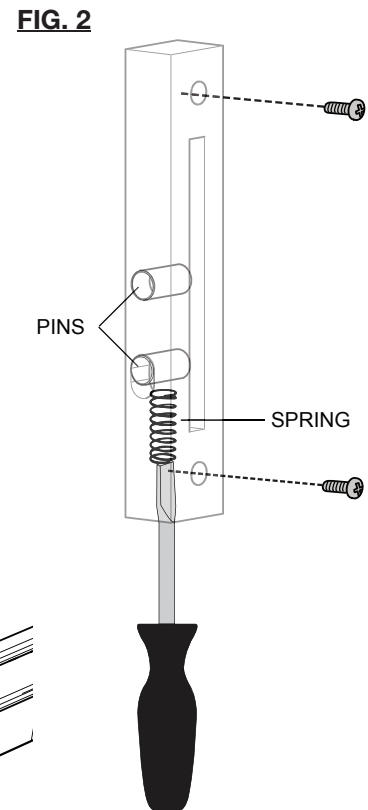
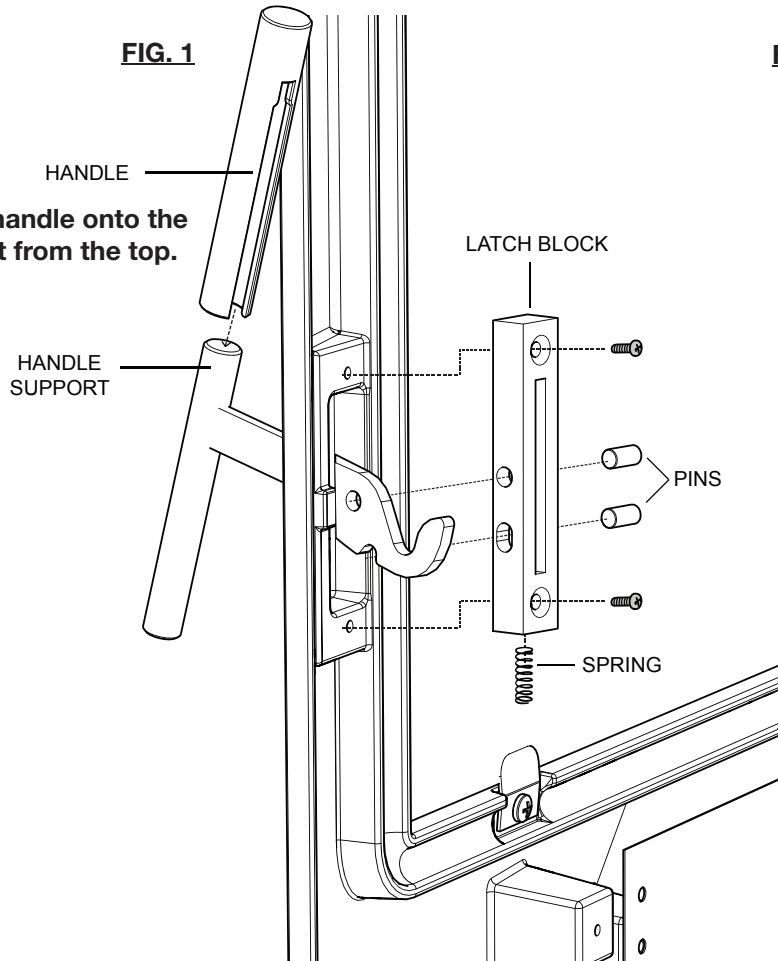

## ! WARNING

- Do not use substitute materials.
- Glass may be hot. Do not touch glass until cooled.
- Care must be taken when removing and disposing of any broken door glass or damaged components. Be sure to vacuum up any broken glass from inside appliance before operation.
- Do not strike, slam, or scratch. Do not operate appliance with glass removed, cracked, broken, or scratched.

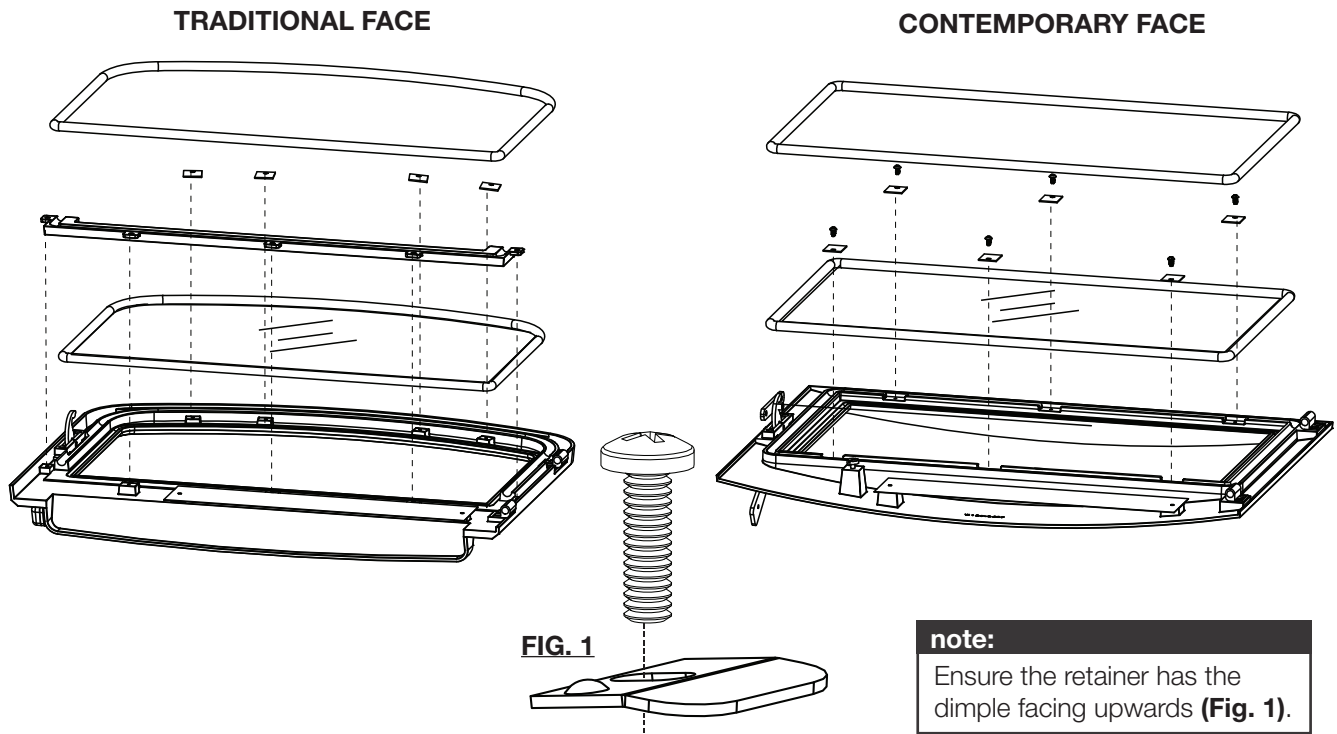

- When the appliance is cool, remove the door from the appliance (see “door removal” section). Place the door face down, being careful not to scratch the paint.
- Take off the existing exterior rope gasket, remove the **9** screws (4 on top, 5 on bottom) on the **traditional face**, or the **6** screws (3 on top, 3 on bottom) on the **contemporary face**. Keep all materials.
- Carefully remove the glass and then the existing interior rope gasket.
- Apply a small bead of silicone in the groove of the interior rope gasket.
- Insert the 1/4” (6.4mm) rope gasket (W562-0043) in the groove, on top of the silicone.
- Place the new glass on the door and reinstall the screws.
- Apply a small bead of silicone in the groove of the exterior rope gasket.
- Insert the 3/4” (19mm) rope gasket (W562-0004) in the groove, on top of the silicone.

At the end of every heating season, inspect the rope gasket on the door to ensure it is secure.

### note:

For more information on glass replacements, see “replacement parts” section.

## 6.8 care of glass

### **WARNING**

- Do not clean glass when hot! Do not use abrasive cleaners to clean glass.

If the glass is not kept clean, permanent discolouration and/or blemishes may result. Normally a hot fire will clean the glass. The most common reasons for dirty glass include:

- Not using sufficient fuel to get the appliance thoroughly hot.
- Using green or wet wood.
- Closing the draft so far that there is insufficient air for complete combustion.

If it is necessary to clean the glass, buff lightly with a clean dry cloth and non-abrasive cleaner. Clean the glass after the first 10 hours of operation with a recommended appliance glass cleaner. Thereafter, clean as required.

The glass is very strong, but do not let burning fuel rest or fall against it and always close the door gently.

**NEVER FORCE OR SLAM IT SHUT!**

Do not operate the appliance with broken glass, as leakage of flue gases may result.

Contact your local authorized dealer/distributor for complete cleaning instructions.

If the glass should ever crack or break while the fire is burning, do not open the door until the fire is out. Do not operate the appliance until the glass has been replaced. Contact your local authorized dealer/distributor for replacement parts. **DO NOT SUBSTITUTE MATERIALS.**



## 6.9 care of plated parts

If the appliance is equipped with plated parts, you must clean fingerprints or other marks from the plated surfaces before operating the appliance for the first time. Use an ammonia-free or vinegar-based cleaner and a towel to clean. If not cleaned properly before operating for the first time, the marks can cause permanent blemishes on the plating. After the plating is cured, the fingerprints and oils will not affect the finish and little maintenance is required, just wipe clean as needed. Prolonged high temperature burning with the door ajar may cause discolouration on plated parts.

**note:**

The protective wrap on plated parts is best removed when the assembly is at room temperature but this can be improved if the assembly is warmed (i.e. using a hair dryer or similar heat source).



## 6.10 blower service or replacement

- A. Turn off all electrical power to the appliance.
- B. Remove 4 screws from blower cover and slide the complete assembly forward.
- C. Detach the blower from the blower cover by removing 2 screws in the middle of the blower cover.
- D. When reconnecting electrical connections, ensure that they remain secure.
- E. To reinstall the blower assembly, reverse these steps.
- F. When reinstalling the blower assembly, ensure that the insulation stays in place.

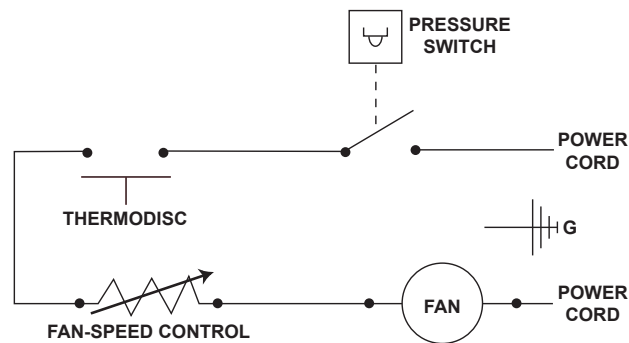
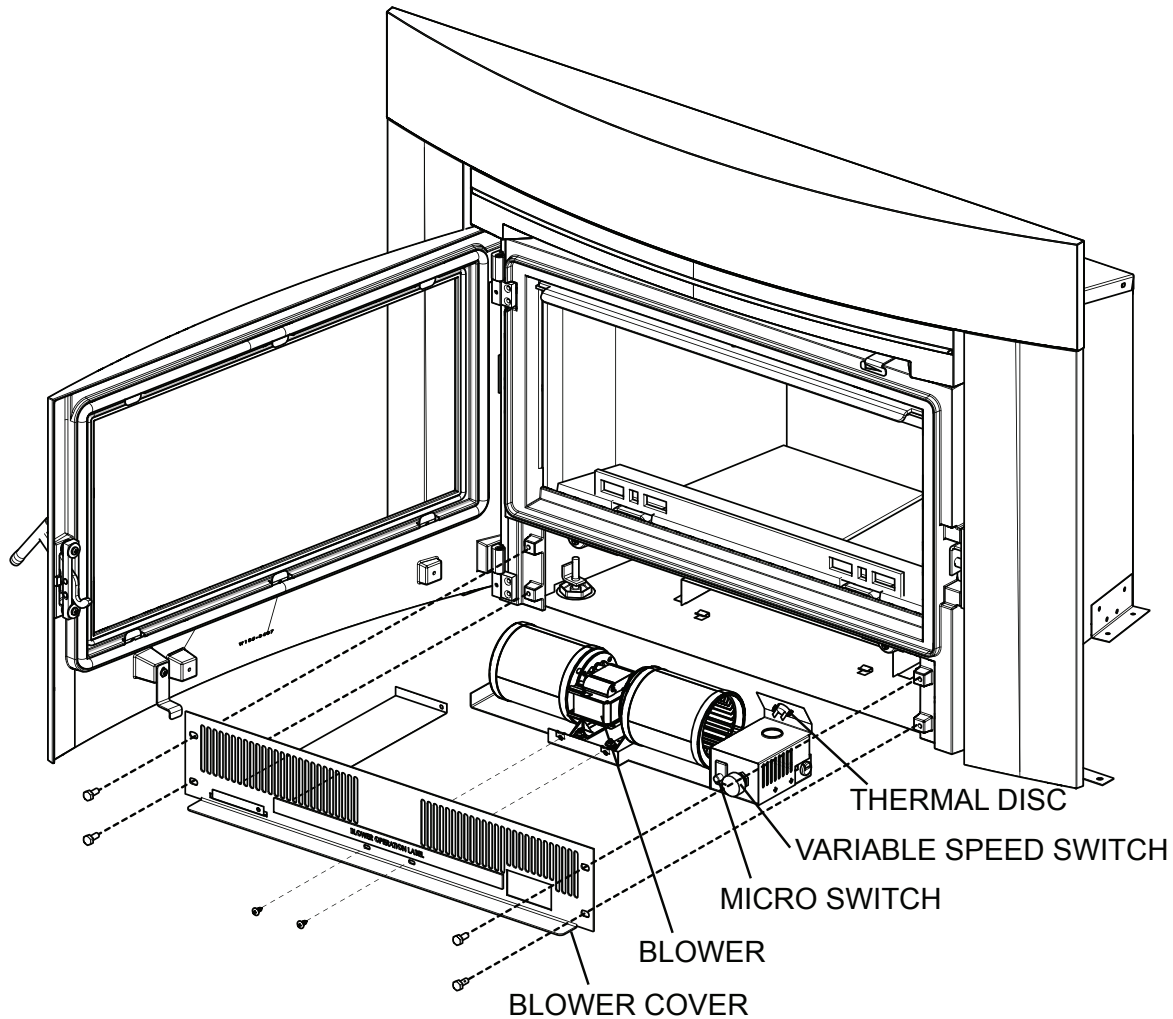

6.11 wood

**! WARNING**

- This appliance is designed to burn natural wood only. Do not burn treated wood, coal, charcoal, coloured paper, cardboard, solvents or garbage. This appliance has not been tested with an unvented gas log set. To reduce risk of fire or injury, do not install an unvented gas log set into the appliance.
- Higher efficiencies and lower emissions generally result when burning air dried seasoned hardwoods, as compared to softwoods or too green or freshly cut hardwoods.
- Burning wet unseasoned wood can cause excessive creosote accumulation. When ignited, it can cause a chimney fire that may result in a serious house fire.
- Do not store fuel within the clearance to combustibles, or in the space required for re-fueling and ash removal.

Before loading the appliance, ensure all required insulation and baffles (if equipped) are installed and situated properly. For maximum efficiency, when the appliance is thoroughly hot, load it fully to the specified maximum amount and burn at a medium low setting (if equipped). The whiteness of the bricks and the cleanliness of the glass are good indicators of your operating efficiency. Not enough heat is produced when only a few pieces of wood are burned or the wood may not burn completely.

**note:**

Appliances surrounded by solid rock or brick will experience a longer heat up period as those materials absorb the heat being generated.

**TYPES OF WOOD**

Both hardwood and softwood burn equally well in this appliance but hardwood is denser, will weigh more per cord and burn a little slower and longer.

Manufactured firelogs made by compressing 100% natural wood fibre can be safely used as fuel. Do not use manufactured firelogs if they contain additives such as paraffin, wax, binders etc. Never burn more than two manufactured firelogs at a time.

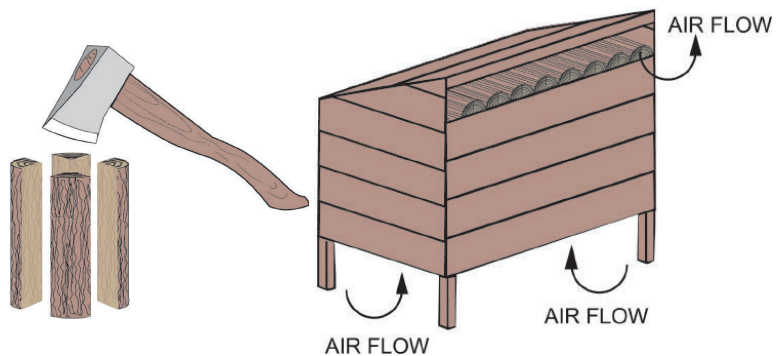

**MOISTURE CONTENT**

Burn only dry, clean unpainted wood that has been seasoned. It produces more heat and less soot or creosote. Freshly cut wood contains about 50% moisture while after proper seasoning only about 20% of the water remains. As wood is burned, this water boils off consuming energy that should be used in heating. The wetter the wood, the less heat is given off and the more creosote is produced. Dry firewood has cracks in the end of the grain.

**STORING WOOD**

Firewood should be split and stacked in a manner that allows for full air circulation and covered in early spring to be ready for burning that fall. Dry firewood has cracks in the end grain.

Cut the wood so that it will fit horizontally, front to back, making for easier loading and less of a likelihood that the wood will roll onto the glass.

Fuel for the appliance must not be stored closer than the required clearances to combustibles (heat sensitive material). **NEVER STORE WOOD IN THE ASH PAN COMPARTMENT (if applicable).**

## 7.0 replacement parts

### **WARNING**

- Failure to position the parts in accordance with this manual or failure to use only parts specifically approved with this appliance may result in property damage or personal injury.

Contact your dealer for questions concerning prices and policies on replacement parts. Normally, all parts can be ordered through your Authorized dealer / distributor.

**For warranty replacement parts, a photocopy of the original invoice will be required to honour the claim.**

When ordering replacement parts always give the following information:

- Model & Serial Number of appliance
- Installation date of appliance
- Part number
- Description of part
- Finish

**Parts, part numbers, and availability are subject to change without notice.**

**Parts identified as stocked will be delivered within 2 to 5 business days for most delivery destinations.**

**Parts not identified as stocked will be delivered within a 2 to 4 week period, for most cases.**

**Parts identified as 'SO' are special order and can take up to 90 days for delivery.**

**7.1 EPI3C-1 overview**

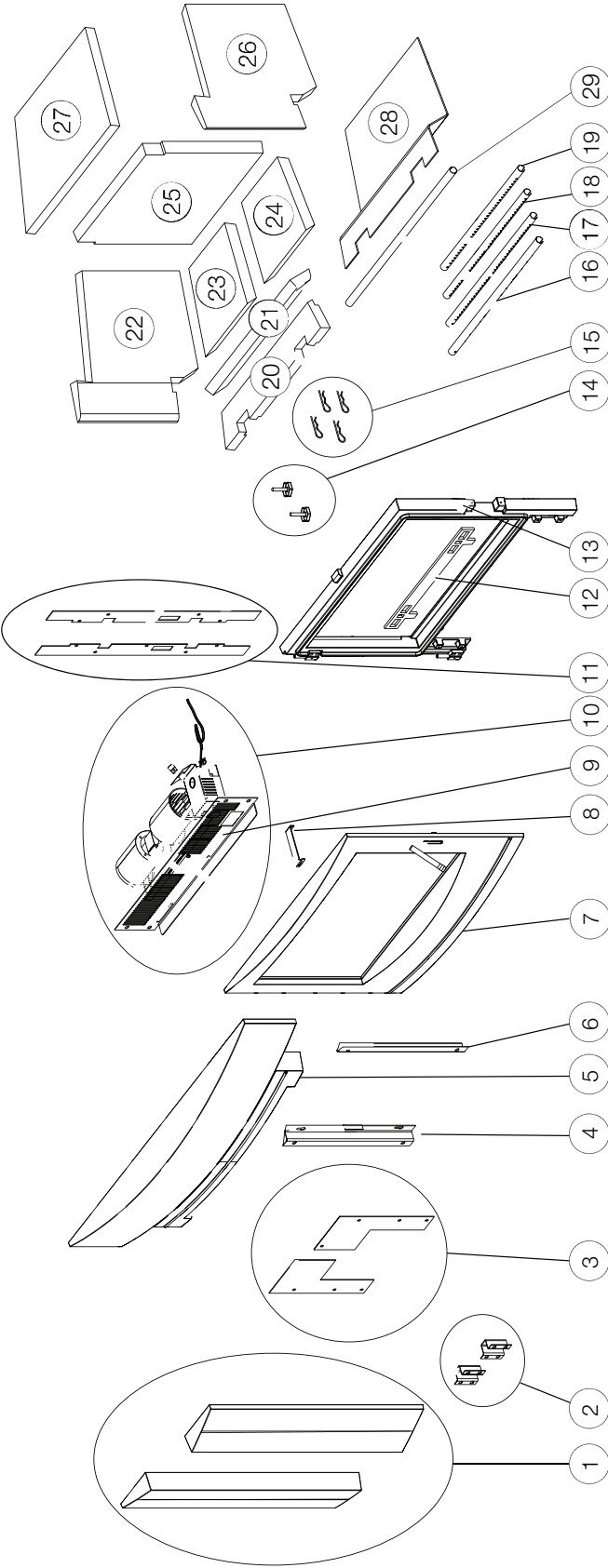

Items may not appear exactly as illustrated.

Ref. No.	Part Number	Description	Stocked
16	W720-0161	Secondary air tube #1	Yes
17	W720-0162	Secondary air tube #2	Yes
18	W720-0163	Secondary air tube #3	Yes
19	W720-0164	Secondary air tube #4	Yes
20	W090-0195	Front ledge brick	Yes
21	W090-0196	Front brick	Yes
22	W090-0191	Left side brick	Yes
23	W090-0194	Bottom brick (LS)	Yes
24	W090-0193	Bottom brick (RS)	Yes
25	W090-0190	Rear brick	Yes
26	W090-0192	Right side brick	Yes
27	W018-0133	Baffle	Yes
28	W361-0189	Firebox insulation	
29	W720-0165	Pilot tube	

Ref. No.	Part Number	Description	Stocked
1	W135-0726	Surround side trim (X2)	
2	W080-1234	Surround bracket (X2)	
3	W655-0899	Surround support (X2)	
4	W500-0966	(L-S) Surround retainer	
5	W135-0727	Surround top trim	
6	W500-0967	(RS) Surround retainer	
7	W010-4221	Door assembly	
8	W190-0053	Air control	
9	W200-0356	Blower cover	
10	W010-2882	Blower assembly	
11	W500-0737	Casting retainer (X2)	
12	W715-0916	Log retainer	Yes
13	W135-0725	EPI3C front	
14	N570-0031	Levelling screws (X2)	
15	W485-0047	Cotter pins (X4)	Yes



7.2 EPI3C-1 door assembly

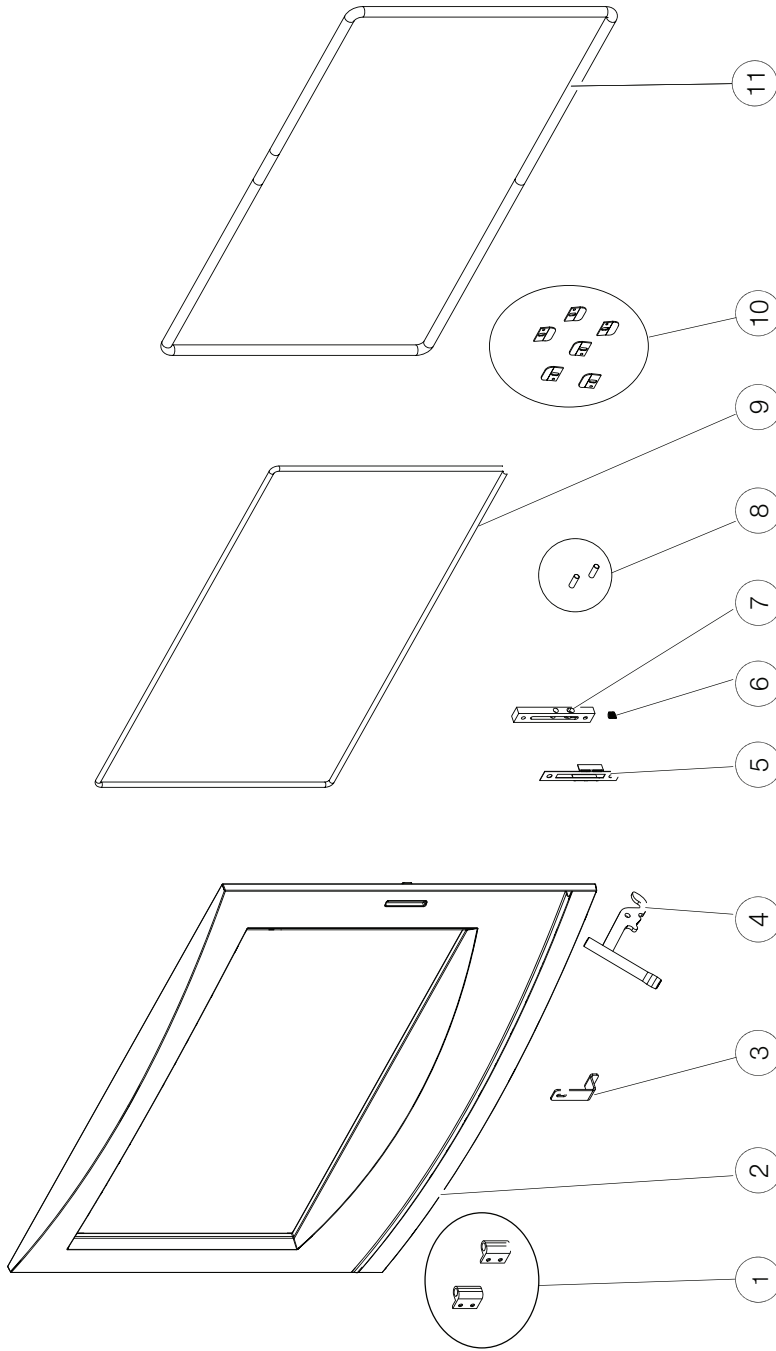

Items may not appear exactly as illustrated.

Ref. No.	Part Number	Description	Stocked
1	W330-0093	Upper door hinge (X2)	
2	W135-0724	Main door	
3	W080-1306	Fan switch bracket	
4	W325-0077-SER	Main door handle	Yes
5	W500-0700	Pin retainer	
6	W630-0024	Spring	Yes
7	W060-0012	Door latch block	Yes

Ref. No.	Part Number	Description	Stocked
8	W485-0052	Dowel pins (X2)	Yes
9	W562-0070	5 ft. of 1/4" rope	Yes
10	W500-0709-SER	Glass retainers (X6)	Yes
11	W562-0004-SER	3/4" rope gasket	Yes

7.3 EPI3T-1 overview

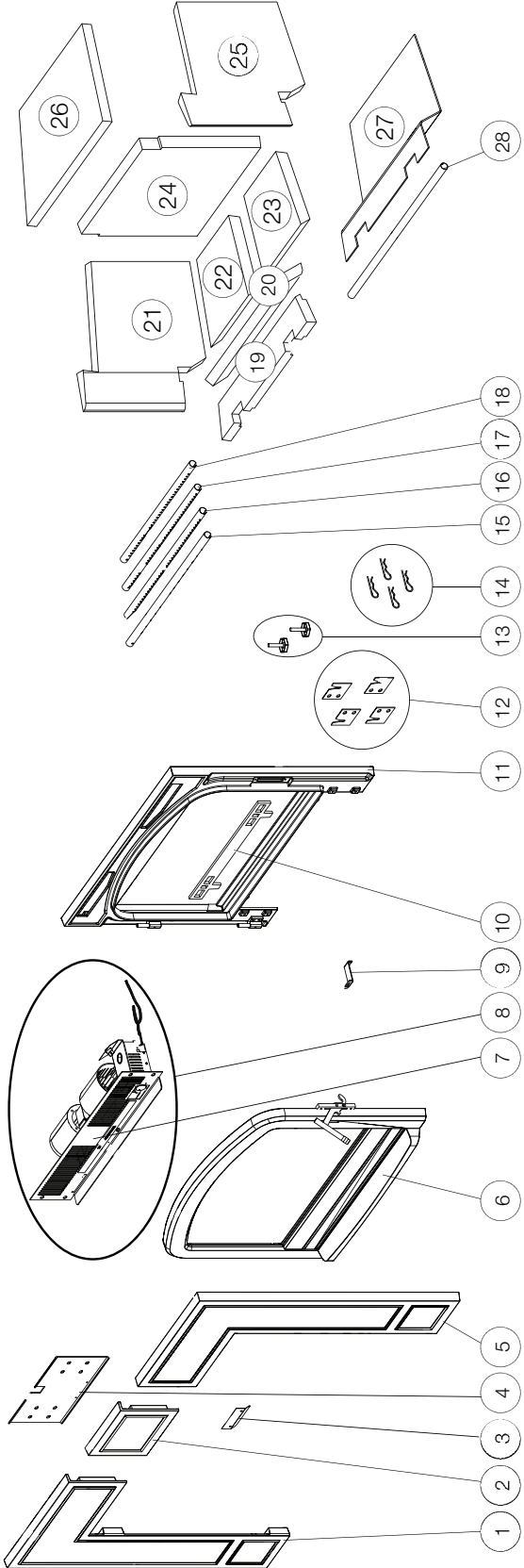

Items may not appear exactly as illustrated.

Ref. No.	Part Number	Description	Stocked
1	W135-0714	Casting, left side	
2	W135-0713	Casting, centre	
3	W655-0469	Casting support	
4	W080-1249	Casting bracket	
5	W135-0715	Casting, right side	
6	W010-4219	Door assembly	
7	W200-0356	Blower cover	
8	W010-2882	Blower assembly	
9	W190-0052	Air control	
10	W715-0916	Log retainer	Yes
11	W135-0642	EPI3T front	
12	W500-0641	Casting retainer (X4)	
13	N570-0031	Levelling screw (X2)	
14	W485-0047	Cotter pin (X4)	Yes
15	W720-0161	Secondary air tube #1	Yes

Ref. No.	Part Number	Description	Stocked
16	W720-0162	Secondary air tube #2	Yes
17	W720-0163	Secondary air tube #3	Yes
18	W720-0164	Secondary air tube #4	Yes
19	W090-0195	Front ledge brick	Yes
20	W090-0196	Front brick	Yes
21	W090-0191	Left side brick	Yes
22	W090-0194	Bottom brick (LS)	Yes
23	W090-0193	Bottom brick (RS)	Yes
24	W090-0190	Rear brick	Yes
25	W090-0192	Right side brick	Yes
26	W018-0133	Baffle	Yes
27	W361-0189	Firebox insulation	
28	W720-0165	Pilot tube	

7.4 EPI3T-1 door assembly

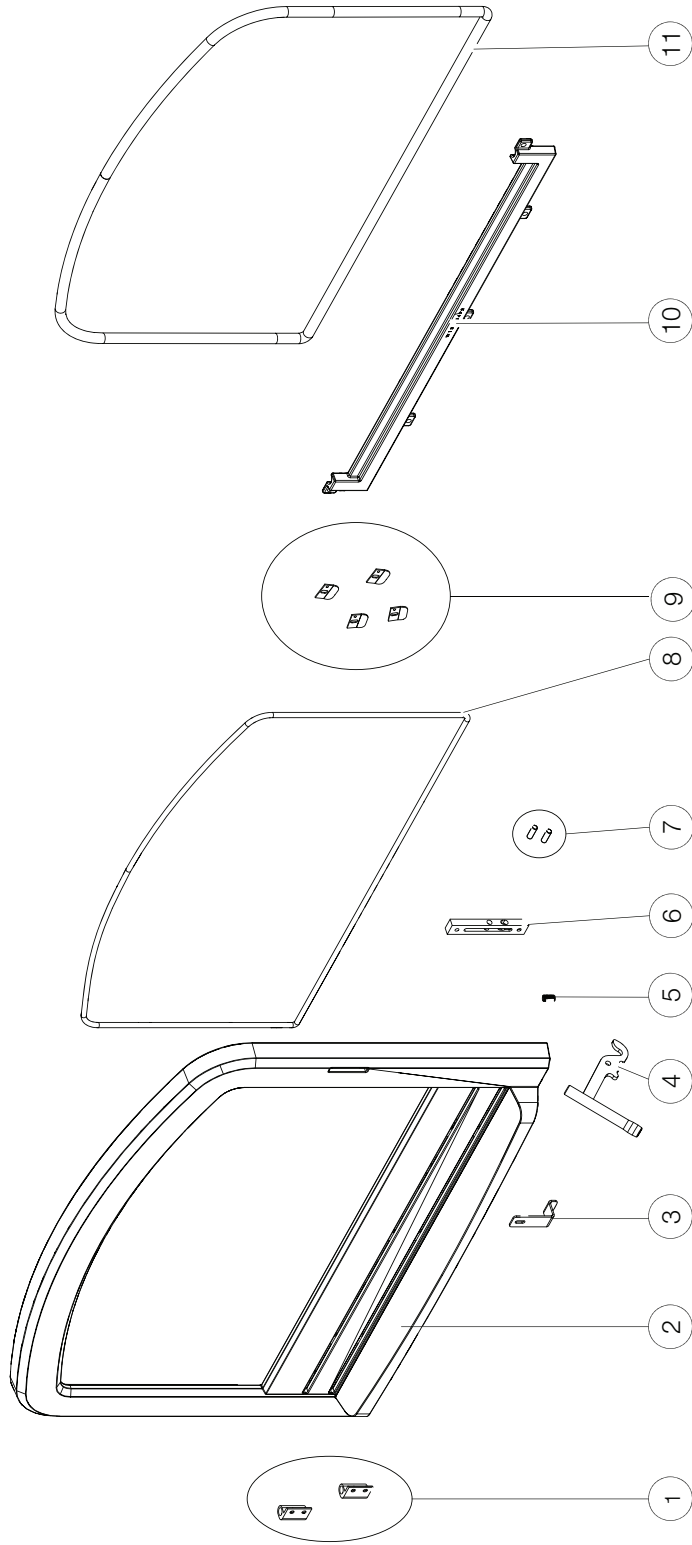

Items may not appear exactly as illustrated.

Ref. No.	Part Number	Description	Stocked
1	W330-0093	Door hinge (X2)	
2	W135-0641	Main door	
3	W080-1306	Fan switch bracket	
4	W325-0077-SER	Main door handle	Yes
5	W630-0024	Spring	Yes
6	W060-0012-SER	Door latch block	Yes
7	W485-0052	Dowel pins (X2)	Yes

Ref. No.	Part Number	Description	Stocked
8	W562-0070	5 ft. of 1/4" rope	Yes
9	W500-0709-SER	Glass retainers (X4)	Yes
10	W135-0716	Glass retainer	
11	W562-0004-SER	3/4" rope gasket	Yes

7.5 EPI3C-1/T blower assembly

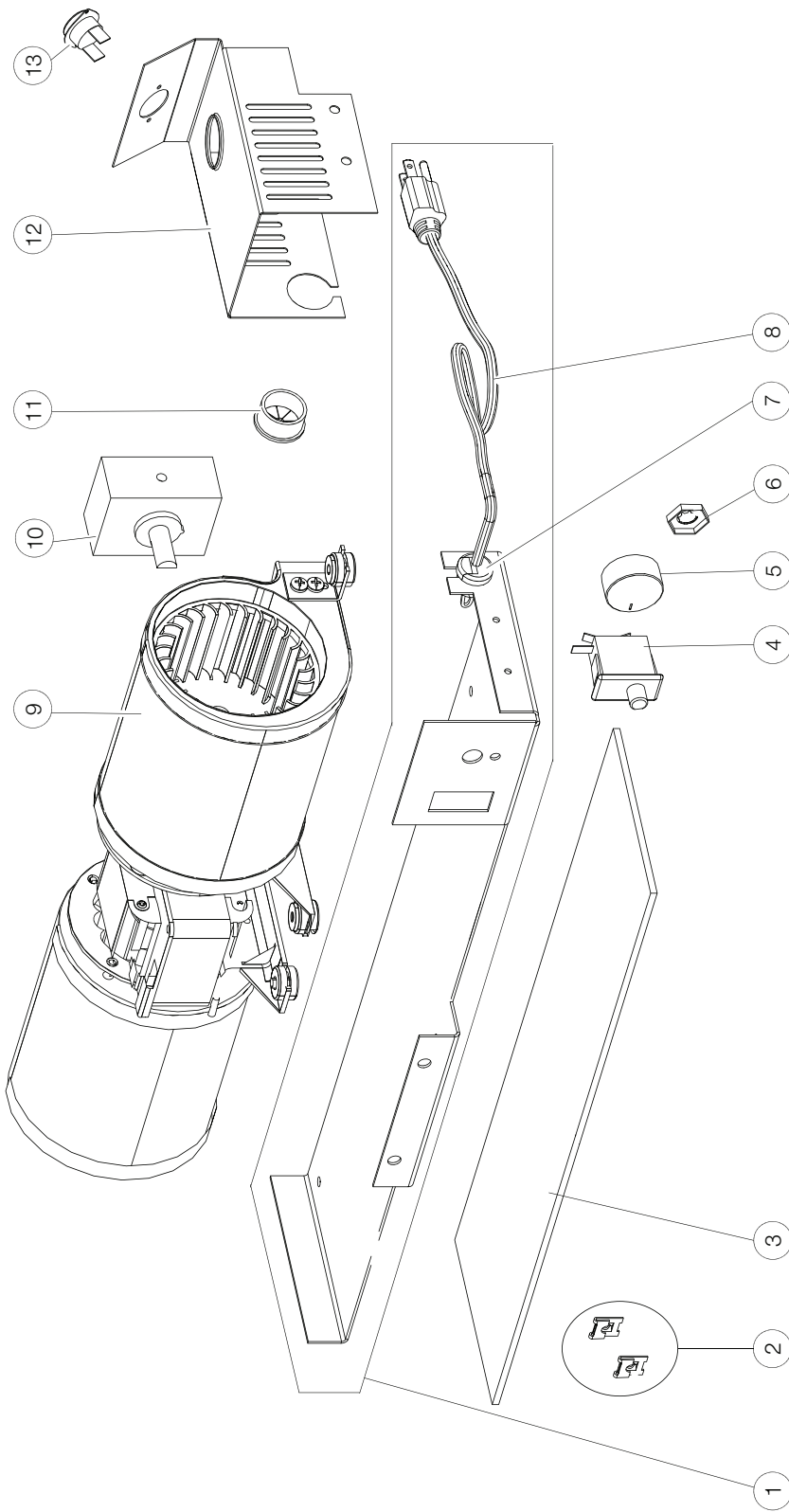

Items may not appear exactly as illustrated.

Ref. No.	Part Number	Description	Stocked
1	W500-0719	Blower plate assembly	
2	W450-0231	Spring nuts (X2)	
3	W290-0229	Vibration damper gasket	
4	W660-0176	Micro switch	Yes
5	W380-0026	Blower knob	Yes
6	W450-0023	Pal nut	
7	W105-0002	Relief bushing	

Ref. No.	Part Number	Description	Stocked
8	W750-0264	Wire harness	Yes
9	W062-0049	Blower	Yes
10	W660-0019	Variable speed switch	
11	W105-0001	Bushing	
12	W550-0689	Electrical housing	
13	W690-0002	Thermidisc	Yes

## 8.0 troubleshooting

### WARNING

- Turn off the appliance completely and let cool before servicing. Only a qualified service person should service and repair this electric appliance.
- Appliance may be hot, do not service until appliance has cooled.
- Do not use abrasive cleaners.
- When checking connections, installing jumper wires (for test purposes only) or replacing components, unplug appliance from the receptacle to prevent electrical shock or damage to the component.

symptom	test solution
Can't get the fire started.	Not enough kindling / paper? Add more.
	Not enough air? Ensure air control is fully open. Also ensure that the air opening is not obstructed.
	Cold air blockage? Burn a piece of paper to establish a draft.
	Use dry seasoned wood with 20% moisture content.
	Flue blockage? Inspect chimney.
Smokes when door is open.	Cold air blockage? Burn a piece of paper to establish a draft.
	Insufficient draft? Add more pipe.
	Let air stabilize before opening door.
	Ensure baffles are positioned correctly.
	Negative pressure? Open a window near the appliance.
Appliance emits odour.	Paint curing, see "general instructions" section.
Stove doesn't burn hot enough.	Wood has more than 20% moisture.
	Insufficient draft? Add more pipe.
	Not enough air? Ensure air control is fully open. Also ensure that the air opening is not obstructed.
Wood burns too fast.	Air control may need to be adjusted down.
	Check to see ash plug is properly seated (if equipped).
	Check door gasket for adequate seal.
	Wood may be extremely dry.
Dirty glass.	Air control may be closed too far.
	Burn hotter, smaller fires.
	Use well seasoned wood with 20% moisture content.
Blower does not run.	Appliance may not be up to temperature.
	Ensure blower has power.
Blower doesn't run	<ul style="list-style-type: none"> <li>- Thermal overload protection has tripped.</li> <li>- Cool the unit down to allow the thermal overload to automatically reset.</li> </ul>
Latch mechanism is sticking/squeeking	<ul style="list-style-type: none"> <li>- Remove the latch block mechanism and grease the spring and pins, see "latch block mechanism replacement" section.</li> </ul>

**Napoleon** Wood Appliances are manufactured under the strict Standard of the world recognized ISO 9001 : 2015 Quality Management System.

**Napoleon** products are designed with superior components and materials assembled by trained craftsmen who take great pride in their work. The complete appliance is again thoroughly inspected by a qualified technician before packaging to ensure that you, the customer, receives the quality product that you expect from **Napoleon**.

### **Napoleon Wood Appliances President's Lifetime Limited Warranty**

The following materials and workmanship in your new **Napoleon** Wood Appliance are warranted against defects for as long as you own the appliance. For pellet appliances this covers: the pellet hopper, outer shell, ceramic glass (thermal breakage only) and ash drawer.\* For wood appliances this covers: combustion chamber, heat exchanger, stainless steel baffle retainer, ceramic glass (thermal breakage only), gold plated parts against tarnishing, porcelainized enameled components, aluminum extrusion trims, vortex baffles, ash drawer and iron castings.\*

For pellet appliances, the combustion chamber and heat exchanger are warranted against defects for a period of 5 years. For wood appliances equipped with a guillotine door/screen system, they are warranted against defects for a period of 5 years.

Electrical (110V) components and wearable parts are covered and **Napoleon** will provide replacement parts free of charge during the first year of the limited warranty. For pellet appliances this covers: blowers, thermal switches and burn pot.\* For wood appliances this covers: blowers, thermal switch, switches, wiring, firebrick, secondary air tubes and gasketing.\*

Labour related to warranty repair is covered free of charge during the first year, with the exception of the guillotine door/screen system which will be warranted for a period of 3 years. Repair work, however, requires the prior approval of an authorized company official. Labour costs to the account of **Napoleon** are based on a predetermined rate schedule and any repair work must be done through an authorized **Napoleon** dealer.

For appliances that include firebricks and baffles, they should routinely be removed by the operator as part of the regular service and therefore, any warranty replacement of these parts does not qualify for any labour allowances.

\* Construction of models vary. Warranty applies only to components included with your specific appliance.

### **Conditions and Limitations**

**Napoleon** warrants its products against manufacturing defects to the original purchaser only. Registering your warranty is not necessary. Simply provide your proof of purchase along with the model and serial number to make a warranty claim. Provided that the purchase was made through an authorized **Napoleon** dealer, your appliance is subject to the following conditions and limitations:

Warranty coverage begins on the date of original installation. This factory warranty is non-transferable and may not be extended whatsoever by any of our representatives. The wood appliance must be installed by a qualified and authorized installer, service agency or supplier. Installation must be done in accordance with the installation instructions included with the product and all local and national building and fire codes. This limited warranty does not cover damages caused by misuse, lack of maintenance, accident, alterations, abuse or neglect. Operating the appliance on high for extended periods of time, is neglect. Parts installed from other manufacturers will nullify this warranty.

This limited warranty further does not cover any scratches, dents, corrosion or discoloring caused by excessive heat, abrasive and chemical cleaners nor chipping on porcelain enamel parts, nor any venting components used in the installation of the appliance. In the first year only, this warranty extends to the repair or replacement of warranted parts which are defective in material or workmanship provided that the product has been operated in accordance with the operation instructions and under normal conditions. After the first year, with respect to the President's Limited Lifetime Warranty, **Napoleon** may, at its discretion, fully discharge all obligations with respect to this warranty by refunding to the original warranted purchaser the wholesale price of any warranted but defective parts. After the first year, **Napoleon** will not be responsible for installation, labour or any other costs or expenses related to the reinstallation of a warranted part, and such expenses are not covered by this warranty. Notwithstanding any provisions contained in the President's Limited Lifetime Warranty, **Napoleon's** responsibility under this warranty is defined as above and it shall not, in any event, extend to any incidental, consequential or indirect damages. This warranty defines the obligations and liability of **Napoleon** with respect to the **Napoleon** wood appliance and any other warranties expressed or implied with respect to this product, its components or accessories are excluded. **Napoleon** neither assumes, nor authorizes any third party to assume, on its behalf, any other liabilities with respect to the sale of this product. **Napoleon** will not be responsible for: over-firing, downdrafts, spillage caused by environmental conditions such as rooftops, buildings, nearby trees, hills, mountains, inadequate vents or ventilation, excessive venting configurations, insufficient makeup air, or negative air pressures which may or may not be caused by mechanical systems such as exhaust blowers, furnaces, clothes dryers, etc.

Any damages to appliance, combustion chamber, heat exchanger, brass trim or other component due to water, weather damage, long periods of dampness, condensation, damaging chemicals or cleaners will not be the responsibility of **Napoleon**. Regular cleaning of the fine ash generated during the operation of this appliance is a necessary part of maintaining your wood appliance. Failure of any components, which is attributed to poor maintenance, is not warrantable and will not be covered by this policy. **Napoleon** reserves the right to have its representative inspect any product or part thereof prior to honouring any warranty claim. All parts replaced under the President's Limited Lifetime Warranty Policy are subject to a single claim. During the first 10 years **Napoleon** will replace or repair the defective parts covered by the lifetime warranty at our discretion free of charge. From 10 years to life, **Napoleon** will provide replacement parts at 50% of the current retail price. All parts replaced under the warranty will be covered for a period of 90 days from the date of their installation. The manufacturer may require that defective parts or products be returned or that digital pictures be provided to support the claim. Returned products are to be shipped prepaid to the manufacturer for investigation. If a product is found to be defective, the manufacturer will repair or replace such defect. Before shipping your appliance or defective components, your dealer must obtain an authorization number. Any merchandise shipped without authorization will be refused and returned to sender. Shipping costs are not covered under this warranty. Additional service fees may apply if you are seeking warranty service from a dealer. Warranty labour allowance is only for the replacement of the warranted part. Travel, diagnostic tests, shipping and other related charges are not covered by this warranty and other related charges are not covered by this warranty.

All specifications and designed are subject to change without prior notice due to on-going product improvements. **Napoleon** is a registered trademark of Wolf Steel Ltd.

# NAPOLEON CELEBRATING OVER 40 YEARS OF HOME COMFORT PRODUCTS



7200, Route Transcanadienne, Montréal, Québec H4T 1A3  
24 Napoleon Road, Barrie, Ontario, Canada L4M 0G8  
214 Bayview Drive, Barrie, Ontario, Canada L4N 4Y8  
103 Miller Drive, Crittenden, Kentucky, USA 41030

Phone: 1-866-820-8686  
[napoleon.com](http://napoleon.com)



**WOLF STEEL LTD.**  
 24 WATFORD ROAD, BARRIE, ON  
 L4M 0G8 CANADA

**NAC**  
 214 BAYVIEW DRIVE, BARRIE, ON  
 L4N 4Y8 CANADA

**WOLF STEEL USA**  
 103 MILLER DRIVE  
 CRITTENDEN, KY 41030-7560

**NAC GUANGZHOU P.R.C.**  
 NO.69 HEFENG ROAD,  
 GUANGZHOU, CHINA

**EPI3, LISTED SOLID FUEL BURNING FIREPLACE INSERT. TESTED TO ULC S628-93 / UL 1482-2011**

**WARNING:** RISK OF SMOKE SPILLAGE. OPERATE ONLY WITH DOOR FULLY CLOSED. REPLACE GLASS ONLY WITH THE CERAMIC GLASS. DO NOT OVERFIRE. IF HEATER OR CHIMNEY CONNECTORS GLOW, YOU ARE OVERFIRING. INSPECT AND CLEAN CHIMNEY FREQUENTLY UNDER CERTAIN CONDITIONS OF USE. CREOSOTE BUILD UP MAY OCCUR RAPIDLY.  
**BLOWER KIT:** 115V, 60HZ, 1.5AMP. ROUTE CORD AWAY FROM UNIT.

**CAUTION:**

HOT WHILE IN OPERATION. DO NOT TOUCH. KEEP CHILDREN AND CLOTHING AND FURNITURE AWAY. CONTACT MAY CAUSE SKIN BURNS.



**DANGER:** RISK OF ELECTRICAL SHOCK. DISCONNECT POWER BEFORE SERVICING UNIT.  
**CHIMNEY CONNECTOR:** 6" (152mm)  
 DO NOT CONNECT THIS UNIT TO A CHIMNEY FLUE SERVING ANOTHER APPLIANCE.  
**FUEL:** FOR USE WITH SOLID WOOD FUEL ONLY. DO NOT USE GRATE OR ELEVATE FIRE - BUILD WOOD FIRE DIRECTLY ON HEARTH.

INSTALLATION INSPECTION AND REPAIR FOR PROPER OPERATION. CONSULT THE OWNER'S MANUAL FOR FURTHER INFORMATION. IT IS AGAINST UNITED STATE FEDERAL REGULATIONS TO OPERATE THIS WOOD APPLIANCE IN A MANNER INCONSISTENT WITH THE U.S. ENVIRONMENTAL PROTECTION AGENCY CERTIFIED TO COMPLY WITH THE particulate emission standards using cordwood. Certifié conforme à la norme d'émission de particules de 2020 en utilisant bois de corde. 40 CFR Part 60, Subpart AAA 1.21 Grams Per Hour / 2020 Cordwood / 1.21 Grammes par heure / Bois de Corde 2020

**Pour le français, l'étiquette arrière.**  
 INSTALL ONLY ON A NON-COMBUSTIBLE HEARTH RAISED (F) 1.5 IN / 38MM ABOVE AN ADJACENT COMBUSTIBLE FLOOR. COMBUSTIBLE FLOOR MUST BE PROTECTED WITH A NON-COMBUSTIBLE WATER-RESISTIVE UNDERLAYMENT (UL) 8 IN MINIMUM THICKNESS. SEE OWNER'S MANUAL FOR ADDITIONAL MANTEL INFORMATION. SEE OWNERS' INSTRUCTION MANUAL FOR MINIMUM CLEARANCE TO COMBUSTIBLE MATERIALS.

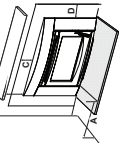

- A ADJACENT SIDEWALL
- B MANTEL
- C TOP FACING
- D SIDE FACING

A) 12" / 305mm  
 B) 16" / 406mm  
 C) 16" / 406mm  
 D) 6" / 152mm

MANUFACTURE DATE:  2019  2020  2021  2022  2023  
 YEAR:  1  2  3  4  5  6  7  8  9  10  11  12  
 MONTH:  1  2  3  4  5  6  7  8  9  10  11  12

DATE CODE

EPI3

W385-2932

**MAXIMUM SIZE:** 14" x 3"

SILVER ON BLACK BACKGROUND

**MATERIAL:** CLASS III A-1 PERMANENT LABEL COMPUJAL

**SPECIFICATIONS:** WATERPROOF, NON-WATER-SOLUBLE ADHESIVE CAPABLE OF WITHSTANDING 250° TEMPERATURES

**SERIAL NUMBER ASCENDING FROM 020661**

"CAUTION" MINIMUM LETTERING SIZE 18PT AND 8.64PT FOR THE REMAINDER OF THAT WARNING

**WOLF STEEL LTD.**

**TITLE:** LABEL, RATING PLATE EPI3-1

**REVISION:**

**DWG #:** W385-2392

**DATE #:** 05.03.19



## APPENDIX 8: Photographs of test set up

**Dilution picture dia 6**

Picture 1 : Sampling system

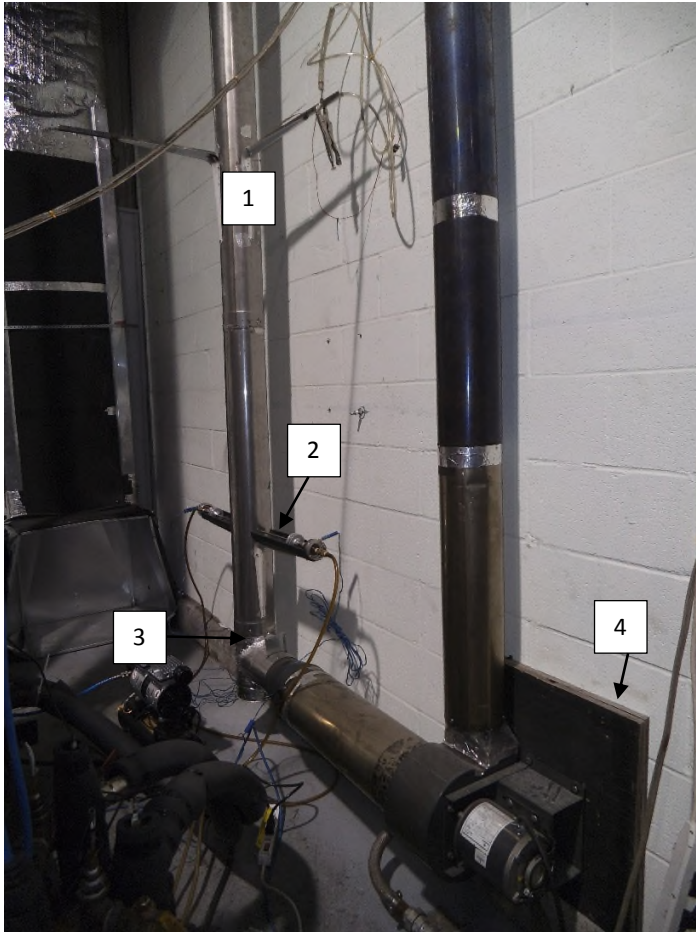

- 1 : 6 in dia Stainless steel pipe
- 2 : 16 in. Between sampling probe and lower elbow
- 3 : Air intake with damper to adjust flow rate
- 4 : Exhaust blower

Picture 2 : Hood and mixing baffle

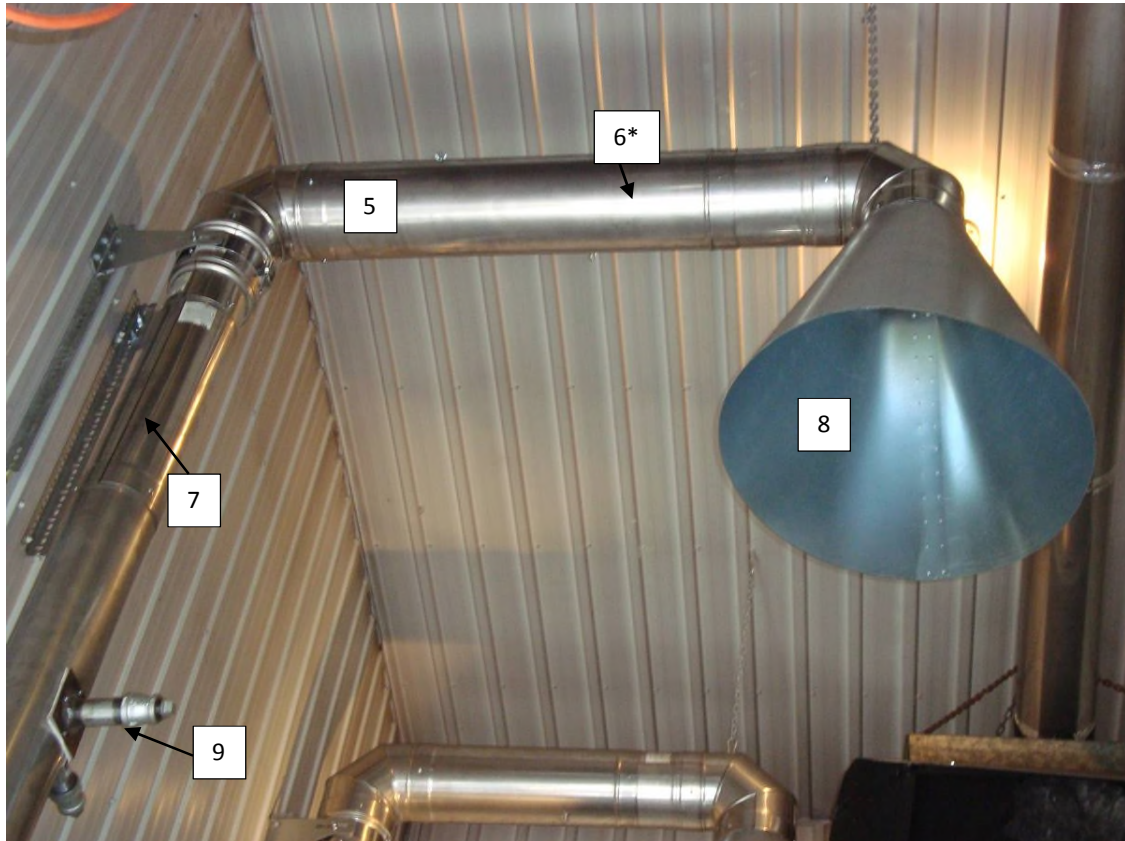

\*The arrow point the deflectors inside of the pipe

- 5 : 8 in. dia. Stainless steel pipe
- 6 : Mixing baffle (2) location 1 foot between baffles
- 7 : 4 feet long between velocity port and upper elbow
- 8 : 24 in. dia. Galvanized steel smoke captures hood, located 3 feet away from dilution tunnel
- 9 : Velocity port

Picture 3: Stack sampling



Picture 3.1: Gas analysis and temperature probe

Picture 3.2: chimney support

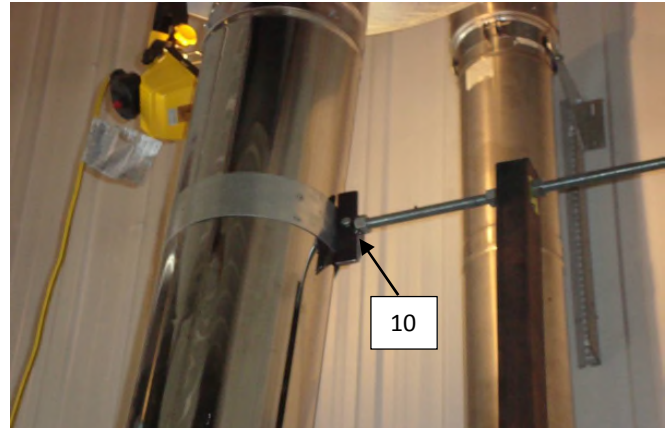
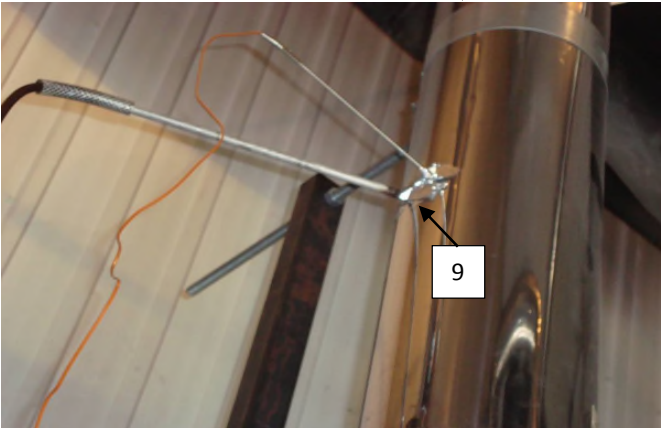

9 : Temperature and gas analyser sampling ports located 9 feet above platform

10 : Exhaust system support bracket

Picture 4: Tunnel flow measurement and sampling probe

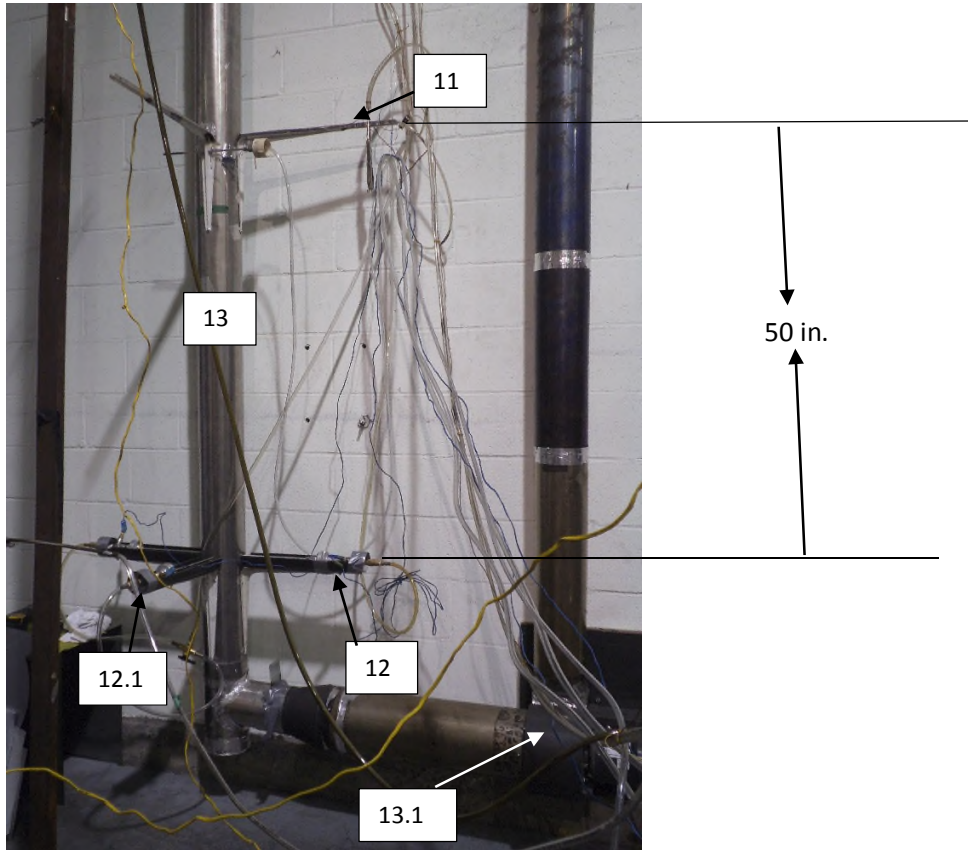

- 11 : Velocity port
- 12 : Sampling port, 2 sampling probes with 2x48 mm. dia.filter each. Filter used: Millipore AP4004700
- 12.1 : Sampling port, sampling probes with 2x48 mm. dia.filter each. Filter used: Millipore AP4004700, for first hour sampling
- 13 : 15 feet long dilution tunnel
- 13.1 : Extraction blower

Picture 5: Draft sampling



14 : Draft sampling port located 6 in. from the flue outlet

Picture 6: Equipments

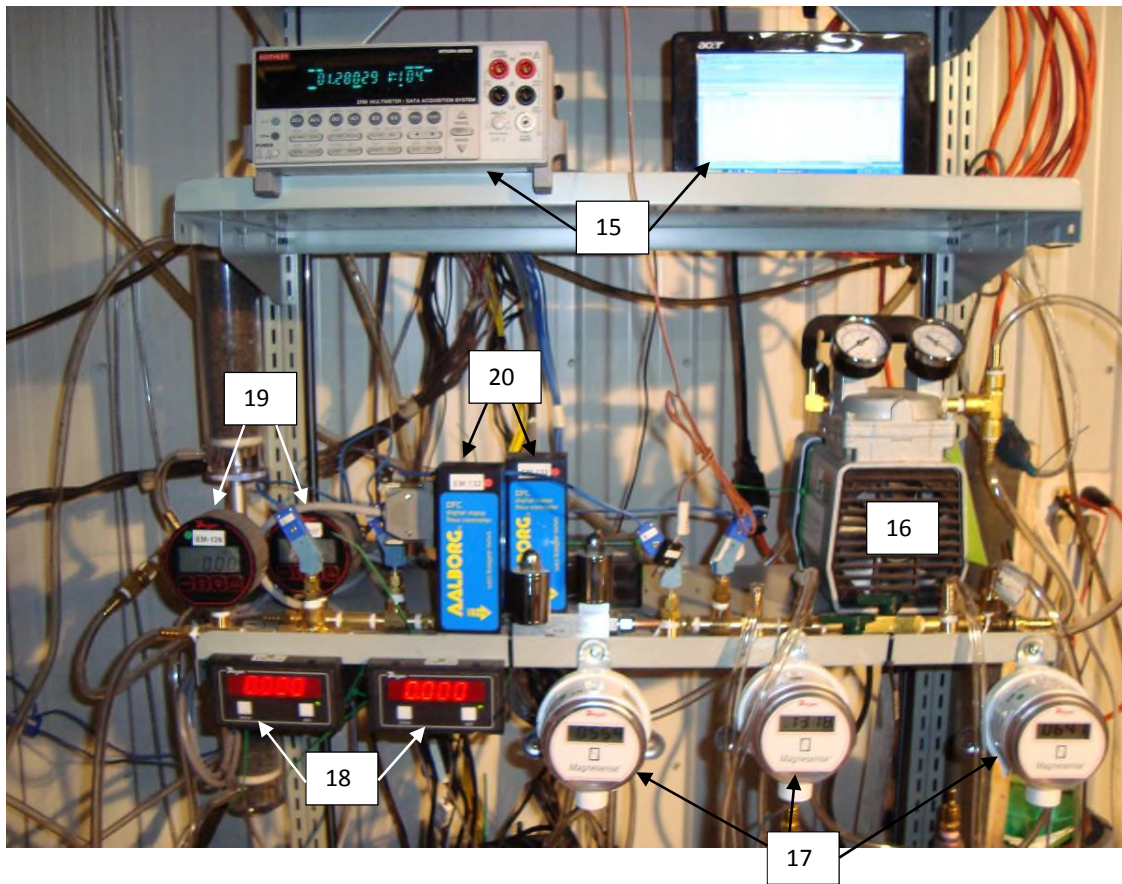

- 15 : Acquisition system
- 16 : Vacuum pump
- 17 : Digital manometer
- 18 : Digital read out for mass flow meter
- 19 : Digital vacuum gage
- 20 : Mass flow meter

Picture 7: Gaz analyser



Picture 8: Reference dry gas meter

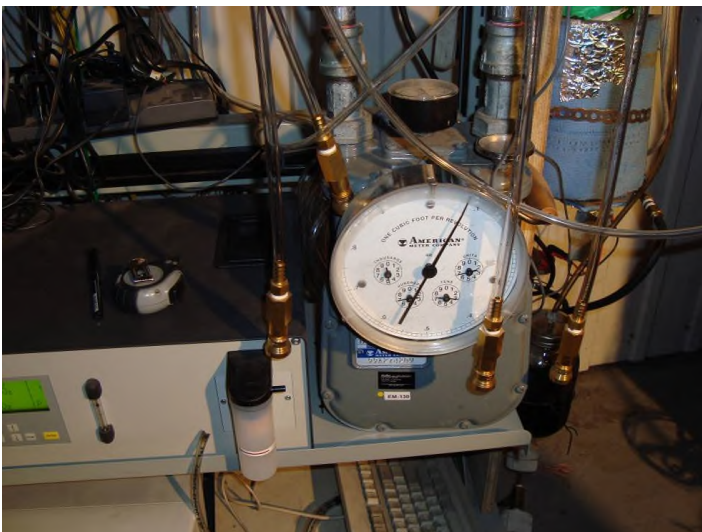



Picture 10: Water flow meter

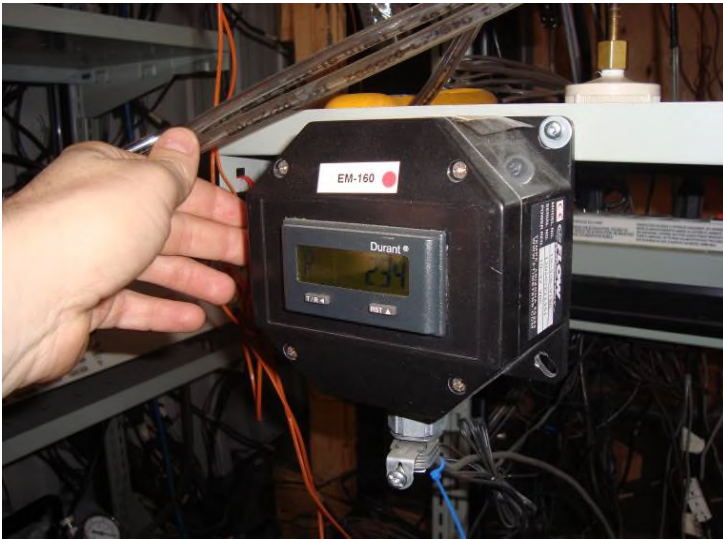

Picture 11: Dry gas meter



Picture 12: Dilution tunnel sample system

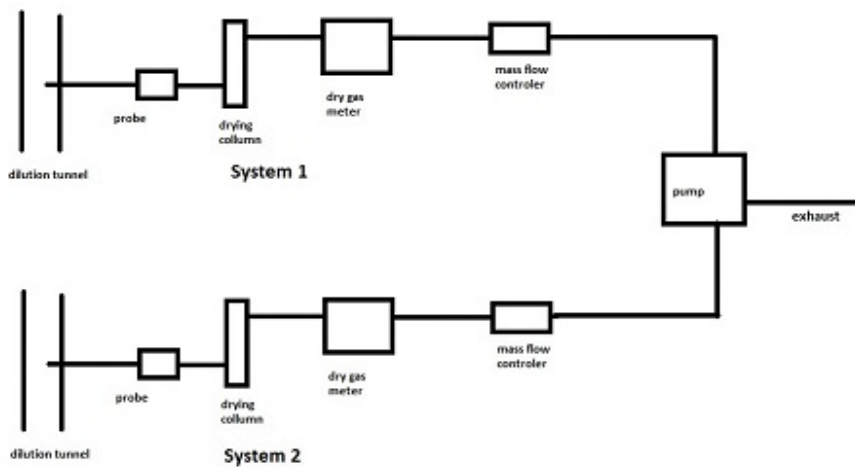

Picture 13: Dilution tunnel

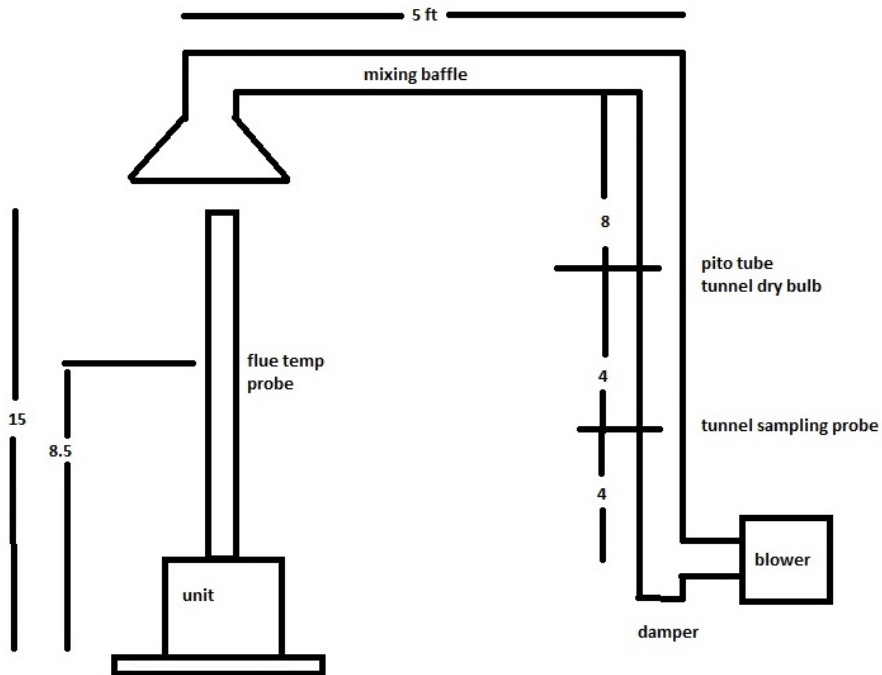

## APPENDIX 9: Test load photographs

**Run 1.1**



**Run 1.2**



Run 2.1



## APPENDIX 10: Laboratory Operating Procedures



# **POLYTESTS Services inc.**

## **SFBA EMISSIONS AND EFFICIENCY TESTING LABORATORY OPERATING PROCEDURE**

### **INTRODUCTION**

This document provides a step by step guide for the technician conducting tests to EPA standard requirements. Procedures outlined here, when followed, will result in tests in conformance with EPA Methods 28R, ASTM E2780, ASTM E2515, ASTM E2618, Method 28WHH, Method 28 PTS, Method ALT-125, ASTM E3053.

The primary measurements to be made are particulate emissions rates. The technician's duties include the following steps.

1. Incoming inspection of test units.
2. Set-up of test units.
3. Preliminary testing to establish unit operating procedures and familiarity with operating controls.
4. Calibration of test equipment.
5. Set-up, checking and operation of sampling apparatus.
6. Conduct of tests including complete record keeping and data recording for non-automated functions.
7. Operation of hardware and software included in automatic data acquisition system.
8. Review and analysis of data at test completion to ensure test validity.

The technician running this test must be familiar with the following documents, which are to be kept in the laboratory at all, times.

### **EPA METHODS**

1. EPA METHODS 28R
2. ASTM E2780
3. ASTM E2515
4. ASTM E2618
5. METHOD 28WHH
6. METHOD 28 PTS
7. ALT-125
8. ASTM E3053

# **POLYTESTS Services** inc.

## SFBA EMISSIONS AND EFFICIENCY TESTING LABORATORY OPERATING PROCEDURE

### I. APPLIANCE INSPECTION AND SET-UP

#### A. INCOMING INSPECTION

1. Check for completeness of unit including parts, accessories, installation and operating instructions, drawings and specifications etc. Note any discrepancies or missing parts or information.
2. Check for shipping damage. If damage has occurred, notify the laboratory manager. In some cases, repairs may be made, provided the manufacturer and laboratory manager concur that repairs will not affect the unit's performance. If damage is irreparable, a new unit will need to be obtained.
3. Note whether unit is catalytic or non-catalytic.
4. Mark unit with manufacturer's name, model number, work order number and date received.
5. If unit is safety listed, note label data including listing agency and serial number. If unit is not listed, mark all data sheets "UNLISTED". Test results will not be released until unit passes safety tests without modification unless authorized by laboratory manager.

#### B. UNIT SET-UP

1. All new units must be operated for a breaking in period as follows.
  - a) Non-catalytic units: Ten (48) hours at medium burn rate with Douglas Fir scrap or cordwood.
  - b) Catalytic units: Fifty (50) hours at medium burn rate with Douglas Fir scrap or cordwood.

During these break-in runs the unit may be connected to a lab chimney and fuel additions noted into the corresponding data acquisition file. For catalytic units, a thermocouple must be installed in the catalyst.

Record catalyst temperature at 1-hour intervals or on chart recorder. Operating should continue until data shows at least fifty (50) hours of operation with catalyst temperature in excess of 500 degrees Fahrenheit (active range).

For non-catalytic units a stack thermocouple should be installed and stack temperature recorded at 1-hour intervals. Fourty-eight (48) hours minimum burn time with a stack temperature of at least 250 degrees Fahrenheit is required.

Once break-in is completed, allow unit to cool. Clean unit thoroughly.

# **POLYTESTS Services inc.**

## **SFBA EMISSIONS AND EFFICIENCY TESTING LABORATORY OPERATING PROCEDURE**

2. Unit is to be placed on scale for testing. Prior to proceeding with verification process, scale should be turned on and allowed to warm up for one (1) hour minimum. Zero scale and check calibration with standard weights. One (1) 1 kg weight and one (1) 2 kg weight are provided for this purpose. Use scale verification test form no. EPA-7-TP to record results. If scale fails to reproduce weights within tolerance, check with laboratory manager before proceeding.
3. If scale checks out, place unit on scale and align so chimney will be centered in hood.
4. Attach chimney connector and chimney. Be sure all joints are sealed below sampling points. Chimney and connector should be cleaned with a wire brush. Be sure chimney connector terminates and chimney starts at proper level above scale platform. Chimney must be supported from scale so that it does not touch test enclosure or hood walls.
5. Thermocouples should be attached to surfaces of unit prior to testing. EPA requires a thermocouple on the bottom of the firebox. This must be installed prior to putting the unit on the scale. In some cases, the required thermocouple locations will be inaccessible on finished units. These units should have thermocouples installed by the manufacturer during construction. Check with the laboratory manager if problems are encountered in proper thermocouple attachment.
6. Measure firebox dimensions and record on data forms nos. EPA-2-TP. Make a three-dimensional sketch of the firebox including firebrick, baffles and obstructions. Calculate firebox volume in cubic feet with both addition and subtraction methods using forms nos. EPA-3-TP and EPA-4-TP. See Section 6.2.4 of EPA Method 28 for details of firebox volume determination.
7. If unit is catalytically equipped, additional thermocouples must be installed upstream and downstream of catalyst. Thermocouples should also be placed in the primary and secondary combustion chambers of all units.
8. Plug thermocouples into data acquisition system jacks making a check of locations and jack numbers for each test on data form no. EPA-5-TP.
9. Note that inserts are tested as if they are freestanding stoves.
10. Dilution tunnel should be cleaned prior to each certification test series and at anytime a higher burn rate follows a lower test burn rate.

# POLYTESTS Services inc.

## SFBA EMISSIONS AND EFFICIENCY TESTING LABORATORY OPERATING PROCEDURE

### II. SAMPLING SYSTEM – SET-UP

#### A. GAS ANALYSIS

1. Instruments should be turned on and allowed to warm up for one (1) hour minimum.

2. Calibrate analyzers as follows:

NOTE : Prior to proceeding with calibration, make sure to use NIST traceable calibration gas bottles. Adjust flow meter if necessary at each instrument to required flow value.

- a) Using span gas, adjust span control to values specified on calibration gas label.
- b) Using nitrogene, adjust zero controls to provide a 0.00 analyzer readout.
- c) Repeat a) and b) until no further adjustment is required.
- d) Check readout vs. calibration gases (2) labels.

The CO<sub>2</sub> and CO analyzers are “ZEROED” on nitrogen. The O<sub>2</sub> analyzer is spanned on air and set for 20.9%. It is zeroed on nitrogen as well.

3. Check for response time synchronization.

- a) With no fire in unit, allow reading to stabilize (O<sub>2</sub> should be 20.93, CO and CO<sub>2</sub> should equal 0).
- b) Flow the calibration gas in the unit and start stop watch. Note the time required for each unit to reach .90 of the calibration gas bottle value. If all three analyzers reach this value within 15 seconds of each other, synchronization is adequate. If not, contact the laboratory manager. Synchronization is adjusted by internal instrument setting.

4. Set-up sample clean-up and water collection train as follows.

- a) Load impingers as follows:  
Impinger #1: 100 ml distilled water and 5 ml H<sub>2</sub>SO<sub>4</sub>  
Impinger #2: 100 ml distilled water and 5 ml H<sub>2</sub>SO<sub>4</sub>  
Impinger #3: Empty  
Impinger #4: 200 – 300 grams silica gel (dry)

# **POLYTESTS Services** inc.

## SFBA EMISSIONS AND EFFICIENCY TESTING LABORATORY OPERATING PROCEDURE

- b) Place impingers in container and connect with "U TUBES". Grease carefully on bottom half of ball joint so that grease will not get into tubes.
- c) Connect filter to first impinger and sample line to last impinger.
- e. Leak check system as follows.
  - 1) Plug probe.
  - 2) Turn on sample system.
  - 3) Observe sample flow rotometer and vacuum gauge. If necessary, use vacuum; adjust valve to set vacuum to the maximum inches Hg.
  - 4) If the float in rotometer does not stabilize below 10 on scale, system must be resealed.
  - 5) Repeat leak check procedure until satisfactory results are obtained.
- f) Just prior to starting test, fill impinger container with water and ice and record ambient conditions on data form no. EPA-8-TP.

### **B. DILUTION TUNNEL SAMPLE TRAIN SET-UP**

- 1. Filters and holders.
  - a) Clean probes and filter holder front housings carefully and desiccate for at least 24 hours prior to use.
  - b) Filters should be numbered and filter and probe combinations labeled prior to use.
  - c) Weigh desiccated filters and probe-filter units on analytical balance. Record weights data form no. EPA-10-TP. Note that probe and front half of front filter are to be weighed as a unit.
  - d) Carefully assemble filter holder units and connect to sampling systems. Check "DRIERITE" columns for adequate dry absorbent (blue).
- 2. Leak checking.
  - a) Each sample system is to be checked for leakage prior to inserting probes in tunnel.
  - b) Plug probes and start samplers, adjust pump bypass valve to produce a vacuum reading of 5 inches Hg. (NOTE: During test, vacuum must not exceed 5 inches unless posttest leak check shows acceptable results.)

# POLYTESTS Services inc.

## SFBA EMISSIONS AND EFFICIENCY TESTING LABORATORY OPERATING PROCEDURE

c) Allow vacuum indication to stabilize for two (2) minutes, then record time and dry gas (DGM<sub>1</sub>) and (DGM<sub>2</sub>) meter readings. Wait ten (10) minutes and record dry gas meter readings again (DGM<sub>3</sub>, DGM<sub>4</sub>). NOTE: If mark, system is leaking too much and all seals should be checked.

d) Calculate leakage rate as follows.

$$1) \text{ System 1: } \frac{(DGM_3 - DGM_1)}{10} = CFM_1$$

$$2) \text{ System 2: } \frac{(DGM_4 - DGM_2)}{10} = CFM_2$$

If CFM<sub>1</sub> or CFM<sub>2</sub> is greater than .02 CFM, leakage is unacceptable and system must be resealed.

If CFM<sub>1</sub> or CFM<sub>2</sub> is greater than 0.04 X sample rate, leakage is unacceptable. For most tests, the sample rate will be about 0.15 CFM, thus leakage rates in excess of 0.04 X 0.15 = 0.006 CFM are not acceptable. Record leakage rates on form no. EPA-5-TP

e) Once leakage check is satisfactory, unplug probe and set flow to appropriate rate for test. This should be done in the minimum amount of time necessary and with the probes in ambient air. Do not insert probes in tunnel until the start of the test run. When flow is established, replug probes to prevent contamination.

### III. TEST CONDUCT

#### A. FUEL LOAD

1. Determine optimum load weight by multiplying firebox volume in cubic feet by 7 or (10 and 12 for cordwood method). This is the load weight on an as-fired basis.
2. Determine piece size to obtain the requested load configuration and meet the test load weight criteria. The load should consist of the following: **TO BE DETERMINED**
3. Weigh out test load and adjust weight by shortening all pieces equally if necessary. Record individual piece load on form no. EPA-11-TP.

# **POLYTESTS Services inc.**

## **SFBA EMISSIONS AND EFFICIENCY TESTING LABORATORY OPERATING PROCEDURE**

4. Measure and record moisture content of each fuel piece using Delmhorst moisture meter. Determine if fuel load moisture content is in required range. If not, construct new load using wood with required moisture content. All wood in the humidity chamber should be within range. Contact project manager if you cannot find suitable pieces. Record moisture of each individual piece load on form no. EPA-11-TP.

### **B. UNIT START-UP**

1. Before lighting a fire, turn on dilution tunnel and set tunnel velocity to 500ft/min Record readings on data form no. EPA-9-TP.
2. Check draft imposed on cold stove with all inlets closed and a draft gauge in the chimney. If draft is greater than 0.005 inches water column, adjust tunnel to stack gap until draft is less than 0.005.
3. Check for ambient airflow around unit with hot wire anemometer. Must be less than 50 ft/min.
4. Check all equipment for proper operation. Analyzers should be on and in sample mode. Computer should be loaded with test program and awaiting test start command.
5. Zero scale and start fire with uncolored newspaper and kindling representing 10 % of test load with the same type of fuel.
6. Once kindling is burning well after 5 minutes, add splitted pieces having a bottom surface around 4 sq. inches and representing 25% of test load weight. Operate at high fire for 15 minutes. Then adjust settings to intended test run levels as per the manufacturer's.
7. Following addition of pretest fuel load (splitted pieces), start computer for data logging.
8. All fuel additions, air intake settings and operational characteristics shall be noted with associated time stamp on form no. EPA-1-TP.

# POLYTESTS Services inc.

## SFBA EMISSIONS AND EFFICIENCY TESTING LABORATORY OPERATING PROCEDURE

### C. TEST RUN

1. Once the targeted test fuel bed weight is obtained, the test is to be started as follows:
  - a) Insert the sample probes into the tunnel being careful not to hit sides of tunnel with probe tip.
  - b) Check tunnel pitot tube for proper position. (Pitot should be carefully cleaned prior to each test.)
  - c) Turn on probe sample systems and stack sampler.
  - d) Open stove door, rake coals and load stove as follows: **TO BE DETERMINED**
  - e) Close door or follow manufacturer's start-up procedures. (Five (5) minutes maximum time before all doors and controls must be set to final positions for duration of test. 15 minutes allowed for ALT-125 method)
  - f) An alarm will sound an audible signal at the (10) minutes intervals. This signal a reading interval. You must verify at each interval that the following readings are correctly logged by the data acquisition system and make observations of any unusual or non-routine events that could occur.
    - 1) Rotometer readings.
    - 2) Tunnel pitot tube reading.  
(Zero regularly between readings)
    - 3) Gas meter readings.
    - 4) Temperature readings.
    - 5) Draft reading
    - 6) Test load weight
    - 7) CO, CO<sub>2</sub> and O<sub>2</sub> readings
    - 8) Observations of any unusual or non-routine events.
  - g) During the test, any condition approaching unacceptable limits will be noted. The filter probes and housings are installed in small holders just outside the tunnel. If the filter temperature gets too high, you will have to increase the water flow through the cooling unit until acceptable temperatures are obtained. In between readings, check on other equipment. Be sure dryers and filters are working and monitor impinger train for proper water and ice levels etc.
  - h) When the fuel charge is consumed, it will signal end of test and shut down the sampling systems. When this occurs,



# **POLYTESTS Services inc.**

## **SFBA EMISSIONS AND EFFICIENCY TESTING LABORATORY OPERATING PROCEDURE**

remove filter holder and probes from tunnel and impingers from sample line.

### **IV. POST TEST PROCEDURES**

#### **A. SAMPLE RECOVERY – FILTER TRAINS**

1. Carefully clean outside of probes and filter housings with alcohol.
2. Disassemble filter holder and transfer filters to clean petri dish. Scrape gasket with scalpel and collect any loose material on filters.
3. Place probe and front half of first filter holders (still assembled) and filters in desiccator. Allow 24-hour desiccation before weighing.
4. Weigh probe filter holder units and filters at six (6) hour intervals until weight change between weighings is less than 0.2 mg. Record all weights taken on data form no. EPA-10-TP.

#### **B. CALCULATION OF RESULTS**

The computer program carries out all final calculations. When run, it will ask for data from forms used during the test. Enter data as called for.

### **GENERAL**

This guide cannot cover every possible contingency, which may develop during a particular test program. Many questions, which may arise, can be answered by a complete understanding of the test standards and their intent. When in doubt on any detail, check with the laboratory manager and be sure you understand the procedures involved.

It is critical that all spaces on the data forms be properly filled in. Each test must be represented by a complete record of what was done and when.

## APPENDIX 11: Sample calculations

**Validation du fichier de calcul avec les équations provenant des normes:**

ASTM E2515-11

ASTME3053-17

Equation 9,2 (1)

$$M_{fldb} = \sum (M_{flnwb}) (100) / (100 + MC_{fln})$$

**Nomenclature**

- $M_{FLdb}$  Weight of test fuel load, dry basis lb (kg)
- $M_{FLnwb}$  Weight of each test fuel pieces, n, in test fuel load per 8,4,1, wet basis, lb (kg)
- $MC_{FLn}$  Average fuel moisture of test fuel piece, n , in test fuel load % dry basis
- n individual test fuel pieces that comprise the test fuel load, as applicable

**Sample calculation**

**Data**

- $M_{FLnwb}$  17,95 lbs
- $MC_{FLn}$  20,40 %
- n
- $M_{FLdb}$  14,91 lbs

Equation 9,2 (2)

$$M_{SUDb} = \sum (M_{SUnwb}) (100) / (100 + MC_{SUn})$$

**Nomenclature**

- $M_{SUDb}$  Weight of startup fuel, dry basis, lb (Kg)
- $M_{SUnwb}$  Weight of each start-up fuel pieces, n, per 8,5,7, wet basis, lb (Kg)
- $MC_{SUn}$  Average fuel moisture of start-up fuel piece, n % bry basis
- n individual startup fuel pieces, as applicable

**Sample calculation**

**Data**

- $M_{SUnwb}$  5,00 lbs
- $MC_{SUn}$  20 %
- n
- $M_{SUDb}$  4,17 lbs

$$\text{Equation 9,2 (3)} \quad M_{kdb} = (M_{kwb})(100)/(100 + MC_k)$$

### Nomenclature

$M_{kdb}$	Weight of kindling, dry basis lb (kg)
$M_{kwb}$	Weight of kindling per 8,5,6, wet basis, lb (kg)
$MC_k$	Average moisture of kindling % dry basis

### Sample calculation

#### Data

$M_{kwb}$	3,50 lbs
$MC_k$	9,00 %
$M_{kdb}$	3,21 lbs

$$\text{Equation 9,2 (4)} \quad M_{FREHdb} = M_{RSUBdb} + M_{FLEHdb}$$

### Nomenclature

$M_{FREHdb}$	Total weight of all remaining fuel at end of high fire test run, lb (kg)
$M_{RSUBdb}$	Weight of residual start-up fuel bed when high fire test load added, lb(kg)
$M_{FLEHdb}$	Weight of unburned portion of test fuel load at the end of the high fire test run, lb (kg)

### Sample calculation

#### Data

$M_{RSUBdb}$	2,70 lbs
$M_{FLEHdb}$	1,64 lbs
$M_{FREHdb}$	4,34 lbs

Equation 9,2 (5)

$$M_{TFBHdb} = M_{Kdb} + M_{SUdb} + M_{FLdb} - M_{FREHdb}$$

### Nomenclature

$M_{TFBHdb}$	Total weight of all fuel burned during high fire test run lb (kg), dry basis
$M_{FREHdb}$	Total weight of all remaining fuel at end of high fire test run, lb (kg)
$M_{FLdb}$	Weight of test fuel load, dry basis lb (kg)
$M_{SUdb}$	Weight of startup fuel, dry basis, lb (Kg)
$M_{kdb}$	Weight of kindling, dry basis lb (kg)

### Sample calculation

#### Data

$M_{FREHdb}$	4,34 lbs
$M_{FLdb}$	14,91 lbs
$M_{SUdb}$	4,17 lbs
$M_{kdb}$	3,21 lbs
$M_{TFBHdb}$	17,95 lbs

Equation 9,2 (6)

$$BR_H = 60(M_{FLdb} - M_{FLEHdb})/\theta_{H1}$$

### Nomenclature

$BR_H$	Dry burn rate for high fire test run, from time when test fuel load added to end of test run
$\theta_{H1}$	Total duration of high fire test run, from time when test fuel load is added to end of test r
$M_{FLdb}$	Weight of test fuel load, dry basis lb (kg)
$M_{FLEHdb}$	Weight of unburned portion of test fuel load at the end of the high fire test run, lb (kg)

## Sample calculation

### Data

$\theta_{H1}$	97 min
$M_{FLdb}$	14,91 lbs
$M_{FLEHdb}$	1,64 lbs
$BR_H$	3,72 kg/hr

For low and medium burn fire test run

Equation 9,2 (7) 
$$M_{TFBdb} = M_{FLdb} - M_{FREdb}$$

### Nomenclature

$M_{TFBdb}$	Total weight of fuel burned during low or medium fire test run, lb (kg),dry basis
$M_{FREdb}$	Weight of remaining fuel at end of low or medium fire test run, lb (kg)
$M_{FLdb}$	Weight of test fuel load, dry basis lb (kg)

## Sample calculation

### Data

$M_{FREdb}$	0,00 lbs
$M_{FLdb}$	17,78 lbs
$M_{TFBdb}$	17,78 lbs

Equation 9,2 (8) 
$$BR = 60(M_{MTBdb}) / \theta$$

### Nomenclature

$BR$	Dry burn rate for low and medium fire test run. lb/hr (kg/hr)
$\theta$	Total duration of low or medium fire test run, min.
$M_{TFBdb}$	Total weight of fuel burned during low or medium fire test run, lb (kg),dry basis

## Sample calculation

### Data

$\theta$  472 min

$M_{TFBdb}$  17,78 lbs

$BR_H$  1,03 kg/hr

For high test run  
Equation 9,2 (9)

$$PM_{RH} = 60(E_{TH}/\theta_{H2})$$

### Nomenclature

$PM_{RH}$  Particulate emission rate for high fire test run, gr/hr

$E_{TH}$  Total particulate emissions for high fire test run including kindling and start-up

$\theta_{H2}$  Total test duration of high fire test run, from ignition of kindling to end of test run

## Sample calculation

### Data

$E_{TH}$  7 gr

$\theta_{H2}$  127,00 min

$PM_{RH}$  3,40 kg/hr

Equation 9,2 (10)

$$PM_{FH} = E_{TH}/M_{TFBdb}$$

### Nomenclature

$PM_{FH}$  Particulate emission rate for high fire test run, gr/hr

## Sample calculation

### Data

$E_{TH}$	7 gr
$M_{TFBHdb}$	17,95 dry lb
$PM_{RH}$	0,88 gr/dry kg

for high fire test run

Equation 9,2 (11)

$$PM_{btuH} = E_{TH} / (M_{TFBHdb} * (HHV) \left( \frac{n_r}{100} \right)) * (10^6)$$

### Nomenclature

$PM_{btuH}$	Particulate per heat output unit for high fire test run, lb/ MMbtu
HHV	Higher heating value of test fuel, dry basis, btu/lb
$n_r$	CSA B415,1 overall Efficiency, HHV (hot to hot)

## Sample calculation

### Data

$E_{TH}$	7,2 gr
$M_{TFBHdb}$	17,95 dry lb
HHV	8690 btu/lb
$n_r$	66,81%
$PM_{btuH}$	0,1523 lb/Mmbtu



Equation 9,2 (12)  $PM_R = 60(E_T/\theta)$

**Nomenclature**

- PM<sub>R</sub> Particulate emission rate for low or medium fire test run, gr/hr
- E<sub>T</sub> Total particulate emission for low or medium fire test run, from ASTM E 2515 (g)
- θ Total duration of low or medium fire test run, min.

**Sample calculation**

**Data**

- E<sub>T</sub> 6 gr
- θ 472 min
- PM<sub>RH</sub> 0,70 gr/hr

---

Equation 9,2 (13)  $PM_F = E_T/M_{TFBdb}$

**Nomenclature**

- PM<sub>F</sub> Particulate emission factor rate for low or medium fire test run, gr/dry kg

**Sample calculation**

**Data**

- E<sub>T</sub> 5,5 gr
- M<sub>TFBdb</sub> 17,78 dry lb
- PM<sub>F</sub> 0,68 gr/dry kg

---

for high fire test run

Equation 9,2 (14)

$$PM_{btu} = E_T / (M_{TFBdb}(HHV)(\frac{n_r}{100})) * (10^6)$$

### Nomenclature

Pmbtu Particulate per heat output unit for low and medium test run, lb/ MMbtu  
 HHV Higher heating value of test fuel, dry basis, btu/lb  
 n<sub>r</sub> CSA B415,1 overall Efficiency, HHV (hot to hot)

### Sample calculation

#### Data

E<sub>TH</sub> 5,5 gr  
 M<sub>TFBdb</sub> 17,78 dry lb  
 HHV 8690 btu/lb  
 n<sub>r</sub> 73,72%  
 PM<sub>btuH</sub> 0,1070 lb/Mmbtu

## Volume of gas sample corrected to dry standard conditions (V<sub>m(std)</sub>)

### Equation used

ASTM 2515, equation 6

$$V_{m(std)} = K_1 V_m Y \left[ \frac{P_{bar} + \left( \frac{\Delta H}{13.6} \right)}{T_m} \right]$$

### Nomenclature

V<sub>m(std)</sub> Volume of gas sample , corrected to standard conditions, dscm<sup>3</sup> (dscf)  
 K<sub>1</sub> 17.64 R/in Hg  
 V<sub>m</sub> Volume of gas sample  
 Y DGM calibration factor  
 P<sub>bar</sub> Barometric pressure mmHg (in Hg)  
 Δ H Average pressure at the outlet of the dry gas meter mm water (in. Water)

$T_m$  Absolute average dry gas meter temperature K (R)

## Sample calculation

### Data

$V_m$  93,32 dcf  
 $Y$  0,98730288  
 $P_{bar}$  30,11 in Hg  
 $\Delta H$  -0,8989 in Hg  
 $T_m$  544,0 R

### Calculation

$V_{m(std)}$  87,26 dscf  
 Calculation based of train 2 data Low fire

## Total amount of particulate matter collected ( $m_n$ )

### Equation used

ASTM 2515, equation 12

$$m_n = F_1 + F_2 + \Delta PF$$

### Nomenclature

$m_n$  Total amount of particulate matter collected, mg  
 $F_1$  Particulate matter collected on front filter, mg  
 $F_2$  Particulate matter collected on second filter, mg  
 $\Delta PF$  Post-test weight gain of probe and filter holder assembly, mg

## Sample calculation

**Data**

F <sub>1</sub>	0,0012 g
F <sub>2</sub>	0,000 g
ΔPF	0,002 g

**Calculation**

m<sub>n</sub> 3,200 mg

Calculation based of train 2 data Low fire

**Particulate concentration (C<sub>S</sub>)****Equation used**

ASTM 2515, equation 13

$$C_S = (0,001 \text{ g/mg}) \times \left( \frac{m_n}{V_{m(std)}} \right)$$

**Nomenclature**

C <sub>S</sub>	Concentration of particulate matter in stack gas or dilution tunnel, dry basis, corrected to standard conditions, g/dsm <sup>3</sup> (g/dscf)
m <sub>n</sub>	Total amount of particulate matter collected in the sampling train, mg
V <sub>m(std)</sub>	Volume of gas sample measured corrected to dry standard conditions, dsm <sup>3</sup> (dscf)

## Sample calculation

### Data

$m_n$  3,200 mg  
 $V_{m(std)}$  87,26 dscf

### Calculation

$C_s$  0,000037 g/dscf  
 Calculation based of train 2 data Low fire

## Particulate concentration for room air ( $C_r$ )

### Equation used

ASTM 2515, equation 14

$$C_r = (0,001 \text{ g/mg}) \times \left( \frac{m_r}{V_{mr(std)}} \right)$$

### Nomenclature

$C_r$  Concentration of particulate matter in room air, dry basis, corrected to standard conditions, g/dsm<sup>3</sup> (g/dscf)  
 $m_r$  Total amount of particulate matter collected in the sampling train, mg  
 $V_{mr(std)}$  Volume of room air sample measured corrected to dry standard conditions, dsm<sup>3</sup> (dscf)

## Sample calculation

### Data

$m_r$  0,200 mg  
 $V_{mr(std)}$  116,96 dscf

### Calculation

$C_r$  0,000002 g/dscf  
Calculation based of train 2 data low

## Adjustment factor for alternative pitot tube placement (FP)

### Equation used

ASTM 2515, equation 1

$$F_P = \frac{V_{strav}}{V_{scnt}}$$

### Nomenclature

$V_{strav}$  Average gas velocity caclulated after the Pitot tube traverse

$V_{scent}$	Average gas velocity at the center of the dilution tunnel cacluated after the multi-point Pitot traverse
$F_p$	Adjustment factor for center of tunnel pitot tube placement

## Sample calculation

### Data

$V_{strav}$	0,237246088
$V_{scent}$	0,23978931

### Calculation

$F_p$	0,989394
-------	----------

## Average dilution tunnel gas velocity ( $V_S$ )

### Equation used

ASTM 2515, equation 9

$$V_S = F_p K_p C_p (\sqrt{\Delta P})_{avg} \sqrt{\frac{T_S}{P_S M_S}}$$

### Nomenclature

$V_S$	Average dilution tunnel gas velocity, m/s (ft/s)
-------	--

K <sub>p</sub>	Pitot tube constant For the metric units: $34.97 \text{ m/sec} \left[ \frac{\left(\frac{\text{g}}{\text{g-mole}}\right)(\text{mm Hg})}{(\text{°K})(\text{mm H}_2\text{O})} \right]^{1/2}$ For English units: $85.49 \text{ ft/sec} \left[ \frac{\left(\frac{\text{lb}}{\text{lb-mole}}\right)(\text{in Hg})}{(\text{°R})(\text{in H}_2\text{O})} \right]^{1/2}$
C <sub>p</sub>	Pitot tube coefficient (use 0.99 for standard pitot tube, 0.84 may be used for S-type tubes constructed according to Method 2 specifications)
F <sub>p</sub>	Pitot tube correction factor
$(\sqrt{\Delta P})_{avg}$	Average square root of each individual velocity head ( $\Delta P$ )
P <sub>bar</sub>	Barometric pressure at measurement site, mm H <sub>2</sub> O (in. H <sub>2</sub> O)
P <sub>g</sub>	Stack static pressure, mm Hg (in. Hg)
P <sub>s</sub>	Absolute dilution tunnel static gas pressure, mm Hg (in. Hg), or P <sub>bar</sub> + P <sub>g</sub>
M <sub>s</sub>	Molecular weight of dilution tunnel gas, wet basis, g/g-mole (lb/lb-mol) may be assumed to be 28.78 or 29 for CSA B415
t <sub>s</sub>	Dilution tunnel temperature, °C (°F)
T <sub>s</sub>	Absolute dilution tunnel temperature, °K (°R), or 273 + t <sub>s</sub> for metric units, 460 + t <sub>s</sub> for English units

### Sample calculation

#### Data

K <sub>p</sub>	85,49	
C <sub>p</sub>	0,99	
F <sub>p</sub>	0,989	
$(\sqrt{\Delta P})_{avg}$	0,2416 in H <sub>2</sub> O <sup>1/2</sup>	
P <sub>bar</sub>	30,11 in Hg	
P <sub>g</sub>	0,24 in H <sub>2</sub> O	<b><u>Calculation</u></b>
P <sub>s</sub>	30,12 in Hg	
M <sub>s</sub>	28,78 lb/lb-mol	V <sub>s</sub> 16,1927 ft/s
t <sub>s</sub>	95,52 F	Calculation based of data low
T <sub>s</sub>	555,52 R	

## Average dilution tunnel gas flow rate (Qstd)

#### Equation used

ASTM 2515, equation 3

$$Q_{std} = 60(1 - B_{ws})V_s A \left(\frac{T_{std}}{T_s}\right) \left(\frac{P_s}{P_{std}}\right)$$



**Nomenclature**

$Q_{std}$	Total gas flow rate corrected to dry standard conditions, $ds\text{m}^3/\text{min}$ (dscf/min)
60	Conversion factor minutes per hour
$B_{WS}$	Water vapour in the dilution tunnel stream, proportion by volume (may be assumed to be 2%)
$V_S$	Average dilution tunnel gas velocity, m/s (ft/s)
A	Cross-sectional area of dilution tunnel, $\text{m}^2$ ( $\text{ft}^2$ )
$T_{std}$	Standard absolute temperature, 293 °K (528°R)
$T_S$	Absolute average dilution tunnel temperature, K (°K), or $273 + t_S$ for metric units, $460 + t$ for English units
$t_S$	Dilution tunnel temperature, °C (°F)
$P_S$	Absolute dilution tunnel static gas pressure, mm Hg (in. Hg), or $P_{bar} + P_g$
$P_{bar}$	Barometric pressure at measurement site, mm Hg (in. Hg)
$P_g$	Dilution tunnel static pressure, mm Hg (in. Hg)
$P_{std}$	Standard absolute pressure, 760 mm Hg (29.92 in. Hg)

**Sample calculation****Data**

$B_{WS}$	0,02
$V_S$	16,193
A	0,349 $\text{ft}^2$
$T_{std}$	528 R
$T_S$	555,52 R
$P_S$	30,124 in Hg
$P_{std}$	29,92 in Hg

**Calculation**

$Q_{std}$  318,04 dscf/min

Calculation based of data low

**Particulate emission rate (E)**

**Equation used**

$$E = (C_s - C_r)Q_{std}$$

**Nomenclature**

E	Particulate emission rate, g/hr
$C_s$	Concentration of particulate matter in stack gas or dilution tunnel gas, dry basis corrected to standard conditions, g/dscm <sup>3</sup> (g/dscf)
$C_r$	Concentration of particulate matter in room air, g/dscm <sup>3</sup> (g/dscf)
$Q_{std}$	Total gas flow rate, dry basis corrected to standard conditions, dsm <sup>3</sup> /min (dscf/min)

**Sample calculation****Data**

$C_s$	0,000037 g/dscf
$C_r$	0,000002 g/dscf
$Q_{std}$	318,04 dscf/min

**Calculation**

E	0,01 g/min
E	0,67 g/h

Calculation based on train 2 data low

## Total particulate emission rate ( $E_T$ )

### Equation used

ASTM 2515, equation 15

$$E_T = (C_S - C_r) Q_{std} \theta$$

### Nomenclature

$E_T$	Total particulate emission, g
$C_S$	Concentration of particulate matter in stack gas or dilution tunnel gas, dry basis corrected to standard conditions, g/dscm <sup>3</sup> (g/dscf)
$C_r$	Concentration of particulate matter in room air, g/dscm <sup>3</sup> (g/dscf)
$Q_{std}$	Total gas flow rate, dry basis corrected to standard conditions, dsm <sup>3</sup> /min (dscf/min)
$\theta$	Total sampling time, min

### Sample calculation

#### Data

$C_S$	0,000037 g/dscf
$C_r$	0,000002 g/dscf
$Q_{std}$	318,04 dscf/min
$\theta$	472 min

#### Calculation

E	5,25 g
---	--------

Calculation based on train 2 data Low

## Average gas velocity in dilution tunnel during each min interval, i, of the test run

### Equation used

ASTM 2515, equation 10

$$v_{si} = F_p K_p C_p \sqrt{\Delta p_i} \sqrt{\frac{T_{si}}{P_s M_s}}$$

### Nomenclature

	Average gas velocity in dilution tunnel during each min interval, i of the test run
$v_{si}$	m/sec (ft/sec)
$F_p$	Pitot tube correction factor
$K_p$	Pitot tube constant
	For the metric units: $34.97 \text{ m/sec} \left[ \frac{(\frac{g}{g\text{-mole}})(\text{mm Hg})}{(^{\circ}\text{K})(\text{mm H}_2\text{O})} \right]^{1/2}$
	For English units: $85.49 \text{ ft/sec} \left[ \frac{(\frac{\text{lb}}{\text{lb-mole}})(\text{in Hg})}{(^{\circ}\text{R})(\text{in H}_2\text{O})} \right]^{1/2}$
$C_p$	Pitot tube coefficient (use 0.99 for standard pitot tube, 0.84 may be used for S-type tubes constructed according to Method 2 specifications)
$\Delta p_i$	interval, i, of the test run
$T_{si}$	Absolute average gas temperature in the dilution tunnel during the $i^{\text{th}}$ minutes
$P_s$	Absolute dilution tunnel static gas pressure, mm Hg (in. Hg), or $P_{\text{bar}} + P_g$
$M_s$	Molecular weight of dilution tunnel gas, wet basis, g/g-mole (lb/lb-mol) may be assumed to be 28.78

### Sample calculation

#### Data

<b>i=1</b>		<b>i=2</b>	
$F_p$	0,989	$F_p$	0,989
$K_p$	85,49	$K_p$	85,49
$C_p$	0,99	$C_p$	0,99
$\Delta p_i$	0,055 in H <sub>2</sub> O	$\Delta p_i$	0,057 in H <sub>2</sub> O
$T_{si}$	568,5 R	$T_{si}$	569,6 R
$P_s$	30,12 in Hg	$P_s$	30,12 in Hg
$M_s$	28,78 lb/lb-mol	$M_s$	28,78 lb/lb-mol

#### Calculation

<b>i=1</b>		<b>i=2</b>	
$v_{si}$	15,90 ft/sec	$v_{si}$	16,17 ft/sec

## Percent of proportional sampling rate (PR)

### Equation used

B415, equation 13.1

$$PR = \left( \frac{\theta V_{mi(std)} V_S T_m T_{Si}}{\theta_i V_m V_{Si} T_{mi} T_S} \right) \times 100$$

### Nomenclature

PR	Percent of proportional sampling rate (%)
$\theta$	Total sampling time, min
$\theta_i$	Time of interval, 1 min
$V_m$	Volume of gas sample measured by the DGM, dsm <sup>3</sup> (dscf)
$V_{mi(std)}$	Volume of gas sample measured by the digital mass flow controller during the i <sup>th</sup> 1 minutes interval, dsm <sup>3</sup> (dscf)
$V_S$	Average gas velocity in the dilution tunnel, ft/min
$V_{Si}$	Average gas velocity in the dilution tunnel during the i <sup>th</sup> 10 minutes interval, ft/min
$T_m$	Absolute average digital mass flow controller temperature, K (R)
$T_{mi}$	Absolute average digital mass flow controller temperature during the i <sup>th</sup> 1 minutes
$T_S$	Absolute average gas temperature in the dilution tunnel, K (R)
$T_{Si}$	Absolute average gas temperature in the dilution tunnel during the i <sup>th</sup> 1 minutes

### Sample calculation

#### Data

train =1			train =2		
$\theta$	472	min	$\theta$	472	min
$\theta_i$	1	min	$\theta_i$	1	min
$V_m$	91,73	dcf	$V_m$	87,30	dcf
$V_{mi(std)}$	0,191	cuft	$V_{mi(std)}$	0,1871	cuft
$V_S$	16,20	ft/sec	$V_S$	16,20	ft/sec
$V_{Si}$	15,908	ft/sec	$V_{Si}$	15,908	ft/sec
$T_m$	543,3	R	$T_m$	544,0	R
$T_{mi}$	537,84	R	$T_{mi}$	538,60	R
$T_S$	555,52	R	$T_S$	555,52	R
$T_{Si}$	568,5	R	$T_{Si}$	568,5	R

#### Calculation

**train=1**

PR

103,6 %

**train=2**

PR

106,5 %

## Filter face velocity check

### Equation used

$$FV_{max} = \frac{V_{mL}}{1} \times \frac{1}{F_A}$$

### Nomenclature

$FV_{max}$  Maximum filter face velocity during the test run, m/min (ft/min)

$V_{mL}$  Largest 1 minute interval metered gas volume value recorded during the test run,  $dm^3$  (dcf)

$F_A$  Filter area exposed to gas sample during train operation,  $m^2$  ( $ft^2$ )

### Sample calculation

#### Data

$V_{mL}$  0,183 dcf

$F_A$  0,0116  $ft^2$

#### Calculation

$FV_{max}$  15,75 ft/min

## Dual train precision

### Equation used

$$\frac{\text{Train 1} - \text{average train 1 and train 2}}{\text{average train 1 and train 2}} \times 100 \leq 7.5\%$$

### Nomenclature

Dual train precision	Deviation between emission's train 1 and 2
Train 1	Total emission for train 1
Train 2	Total emission for train 2

### Sample calculation

#### Data

Train 1	5,80 g
Train 2	5,25 g

#### Calculation

Dual train precision	5,00 %
----------------------	--------

## Analyzer drift checks

### Equation used

$$Drift = \frac{\Delta R}{span} \times 100$$

### Nomenclature

Drift	The change in analyzer response to calibration gas over the duration of the test run
$\Delta R$	The difference between the analyzer response at the end of the test run and the
Span	The upper limit of the instrument range, ppmv or %

### Sample calculation

#### Data

$\Delta R$	0,015 %
Span	5 %

#### Calculation

Drift	0,30 %
-------	--------

Calculated with CO concentration values.



## APPENDIX 12: Volume calculations

DIMENSIONS OF FIREBOX SECTION

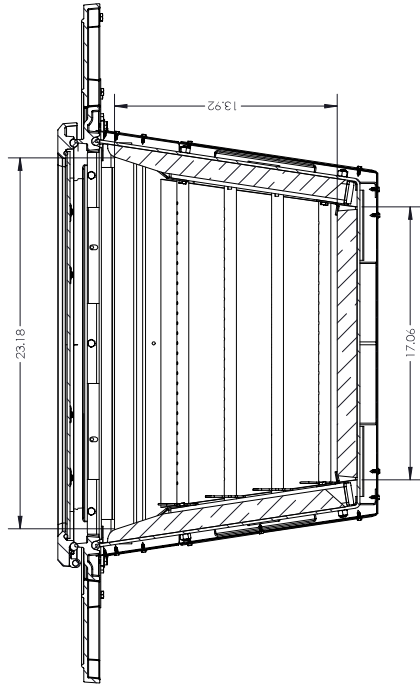

FIREBOX VOLUME CALCULATION:

TOP SECTION AREA =  $1/2(23.18 + 17.06) \times 13.92 = 280.07$  sq.in.  
 FIREBOX VOLUME =  $280.07 \times 11.09 = 3105.97$  cu.in. = 1.79 cu.ft.

SECTION B-B  
SCALE 1 : 6

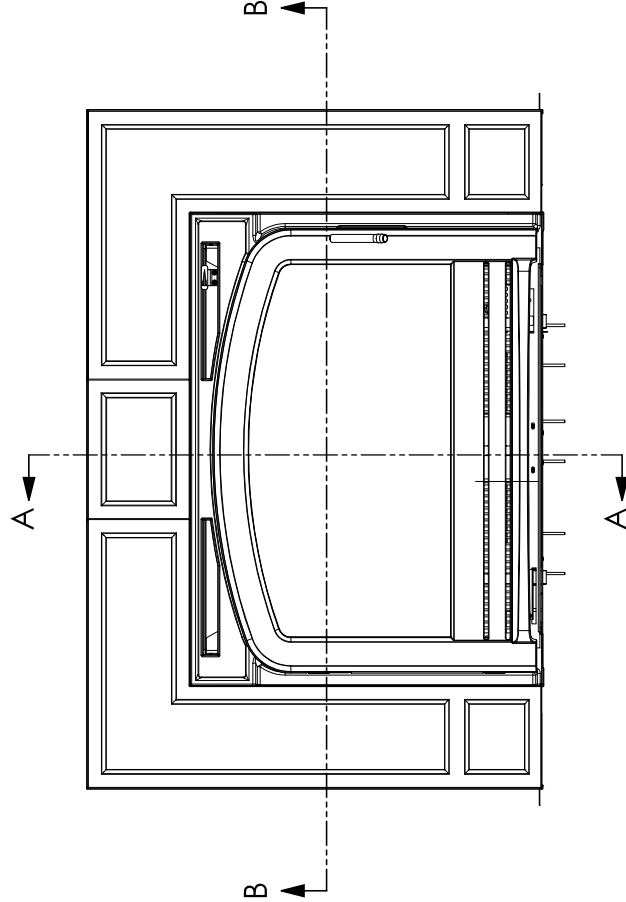

FIREBOX HEIGHT

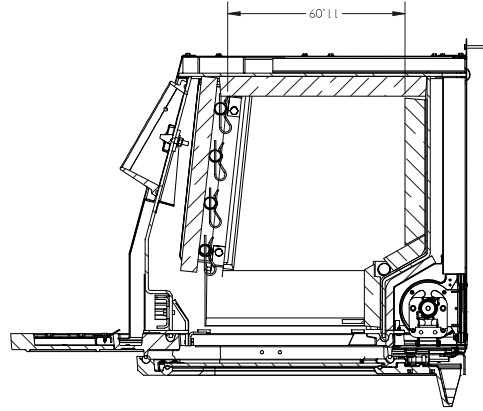

SECTION A-A  
SCALE 1 : 6

<small>Not to be used for any other purpose without the written consent of the manufacturer. All surfaces are considered class 2.</small> <b>WOLF STEEL</b> <small>WOLF STEEL CORPORATION</small>		TITLE: <b>ASSEMBLY EPI3-1</b> MATERIAL: FINISH: REVISION:	MODEL: <b>EPI3-1</b> THICKNESS: <b>397.074 LBS</b> COMP:	DRAWING: <b>EPI3-1</b> ISSUE DATE: <b>UNRELEASED</b> SHEET 2 OF 2 DRAWN BY:	PROJECT LEAD: <b>P. HODGES</b> REV NOTE:
<small>UNLESS OTHERWISE NOTED OR SPECIFIED ALL SURFACES ARE CONSIDERED CLASS 2.</small>		REVISION:	REV DATE:	SCALE: <b>1:12</b>	CHECKED BY: <b>UNRELEASED</b>

## APPENDIX 13: Operating instruction

**Operating instruction for High burn rate Cord wood method ALT-125, ASTM E3053**

- Start the fire with approximately 5 lbs. of startup fuel, 3.5 lbs. of kindling.
- close the door.
- When left approximately 2.7 lbs. from the startup load, the high burn rate load can be inserted.
- The high bur rate load can be up to 18 lbs. open the door, load the stove with high burn load.
- Close the door right after loading
- Optional fan is set at high position and operate with a thermodic located at the back of the firebox.

**Operating instruction for Medium burn rate Cord wood method ALT-125, ASTM E3053**

- From the high burn rate coal bed, when 3.9 lbs. left, the load can be inserted in the firebox.
- open the door
- Insert the 21.5 lbs. load in the wood heater
- Close the door right after loading
- Keep the combustion air damper fully open for 13 minutes, then gradually close to air damper to the medium setting
- At 15 minutes close the combustion air damper to the medium setting.
- No fan for the medium setting.

**Operating instruction for Low burn rate Cord wood method ALT-125, ASTM E3053**

- From the high burn rate coal bed, when 3.8 lbs. left, the load can be inserted in the firebox.
- open the door
- Insert the 21.5 lbs. load in the wood heater
- Close the door right after loading
- Keep the combustion air damper fully open for 13 minutes, then gradually close to air damper to the minimum setting
- At 15 minutes fully close the combustion air damper (lowest setting).

## APPENDIX 14: Drawing Air flow pattern

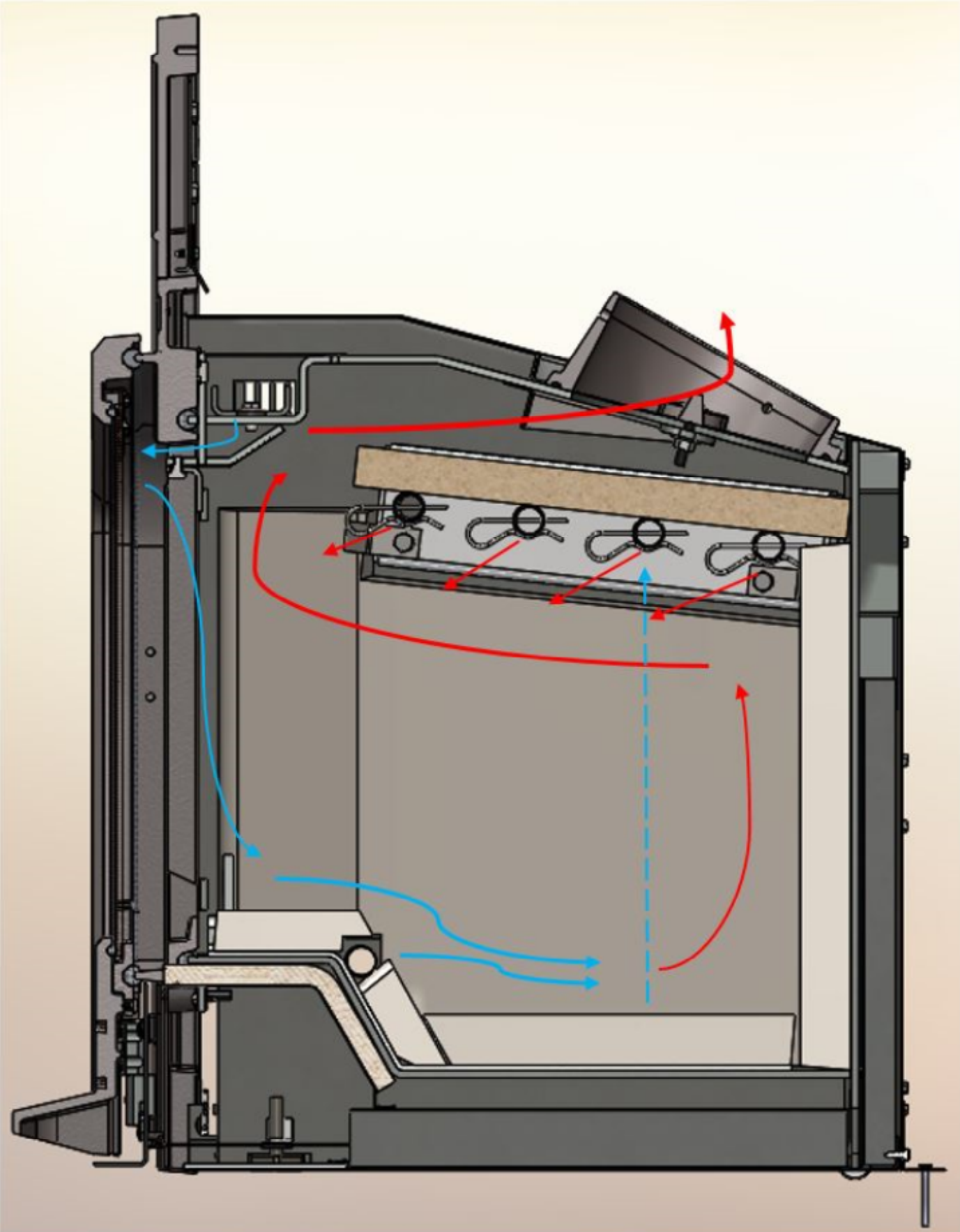

## APPENDIX 15: Application for wood stove program

**U.S. ENVIRONMENTAL PROTECTION AGENCY (EPA)  
30-DAY NOTIFICATION FORM  
PURSUANT TO 40 CFR PART 60 SUBPARTS AAA AND QQQQ  
2015 STANDARDS OF PERFORMANCE FOR NEW RESIDENTIAL WOOD HEATERS, NEW  
RESIDENTIAL HYDRONIC HEATERS AND FORCED-AIR FURNACES**

**Disclaimer:** The statutory provisions and the EPA regulations described in this document contain legally binding requirements. This document is not a substitute for those provisions or regulations, nor is it a regulation itself. In the event of a discrepancy, please refer to 40 CFR PART 60 Subparts AAA AND QQQQ, Sections 60.533 and 60.5475. This document may be revised periodically without public notice. If you have additional questions, please contact Rafael Sanchez at 202-564-7028 or via email at [sanchez.rafael@epa.gov](mailto:sanchez.rafael@epa.gov).

- ▶ The manufacturer of an affected wood/pellet heater/central heater model line must notify the Administrator of the date that certification testing is scheduled to begin by email to [WoodHeaterReports@epa.gov](mailto:WoodHeaterReports@epa.gov).
- ▶ This notice must be received by the EPA at least 30 days before the start of testing.

**GENERAL INFORMATION**

**Manufacturer's Name:**  
Wolf Steel Ltd.

<b>Appliance Type (Circle One):</b>	Adjustable Burn Rate Wood Heater	Pellet Stove	Single Burn Rate Heater	Hydronic Heater	Forced Air Furnace	Other:
<b>Hydronic Heater Type (Circle One):</b>	Traditional	Full Storage	Partial Storage	Indoor/Outdoor	Other:	
<b>Forced-Air Furnace Type (Circle One):</b>	Small (less than 65,000 BTU/hr heat output)		Large (greater than 65,000 BTU/hr heat output)		Other:	
<b>Fuel Type:</b>	Crib	Pellet	Cordwood	Other:		

**Model Name and Number:**  
EPI3

**Catalyst:** Yes \_\_\_\_\_ No  X \_\_\_\_\_

**Mailing Address:**

**Street Address:**  
24 Napoleon Rd.

<b>City:</b> Barrie	<b>State:</b> Ontario	<b>ZIP Code:</b> L4M 0G8
<b>Phone:</b> 705 721 1212	<b>Fax:</b>	<b>Web Site:</b> <a href="http://www.napoleon.com">www.napoleon.com</a>

**Address of Manufacturing Facility:**

9 Napoleon Rd.

<b>City:</b> Barrie	<b>State:</b> Ontario	<b>ZIP Code:</b> L4M 0G8
------------------------	--------------------------	-----------------------------

**EPA APPROVED TEST LABORATORY**

**Name and Title of Authorized Representative:** Danick Power

**Company:** Services Polytests inc.



**U.S. ENVIRONMENTAL PROTECTION AGENCY (EPA)  
30-DAY NOTIFICATION FORM  
PURSUANT TO 40 CFR PART 60 SUBPARTS AAA AND QQQQ  
2015 STANDARDS OF PERFORMANCE FOR NEW RESIDENTIAL WOOD HEATERS, NEW  
RESIDENTIAL HYDRONIC HEATERS AND FORCED-AIR FURNACES**

**Disclaimer:** The statutory provisions and the EPA regulations described in this document contain legally binding requirements. This document is not a substitute for those provisions or regulations, nor is it a regulation itself. In the event of a discrepancy, please refer to 40 CFR PART 60 Subparts AAA AND QQQQ, Sections 60.533 and 60.5475. This document may be revised periodically without public notice. If you have additional questions, please contact Rafael Sanchez at 202-564-7028 or via email at [sanchez.rafael@epa.gov](mailto:sanchez.rafael@epa.gov).

- ▶ The manufacturer of an affected wood/pellet heater/central heater model line must notify the Administrator of the date that certification testing is scheduled to begin by email to [WoodHeaterReports@epa.gov](mailto:WoodHeaterReports@epa.gov).
- ▶ This notice must be received by the EPA at least 30 days before the start of testing.

<b>Phone: 450 741-3636</b>	<b>E-mail: Dpower@polytests.com</b>	<b>Fax: NA</b>
<b>City: St-jean-sur-richelieu</b>	<b>State: Canada, Quebec</b>	<b>ZIP Code: J3B 7S7</b>

**EPA APPROVED THIRD-PARTY CERTIFIER**

**Name and Title of Authorized Representative:**  
Ryan Beard, C. Tech, Certifier – Fuels Group CSA

**Company:**  
CSA Group

<b>Phone: 416 747 2630</b>	<b>E-mail: Ryan.beard@csagroup.org</b>	<b>Fax: 416 401 6800</b>
<b>City: Toronto</b>	<b>State: Ontario</b>	<b>ZIP Code: M9W 1R3</b>

**COMPLIANCE TEST INFORMATION**

**Test Method(s):**

**ASTM E3053-17**

**Date(s) of Proposed Test:**  
April 1<sup>st</sup> – 5<sup>th</sup> 2019

**Testing Location:**

Polytests Services Inc.  
695 B rue Gaudette,  
St-Jean-sur-Richelieu  
Québec, Canada, J3B 7S7  
450.741.3636

**U.S. ENVIRONMENTAL PROTECTION AGENCY (EPA)  
30-DAY NOTIFICATION FORM  
PURSUANT TO 40 CFR PART 60 SUBPARTS AAA AND QQQQ  
2015 STANDARDS OF PERFORMANCE FOR NEW RESIDENTIAL WOOD HEATERS, NEW  
RESIDENTIAL HYDRONIC HEATERS AND FORCED-AIR FURNACES**

**Disclaimer:** The statutory provisions and the EPA regulations described in this document contain legally binding requirements. This document is not a substitute for those provisions or regulations, nor is it a regulation itself. In the event of a discrepancy, please refer to 40 CFR PART 60 Subparts AAA AND QQQQ, Sections 60.533 and 60.5475. This document may be revised periodically without public notice. If you have additional questions, please contact Rafael Sanchez at 202-564-7028 or via email at [sanchez.rafael@epa.gov](mailto:sanchez.rafael@epa.gov).

- ▶ The manufacturer of an affected wood/pellet heater/central heater model line must notify the Administrator of the date that certification testing is scheduled to begin by email to [WoodHeaterReports@epa.gov](mailto:WoodHeaterReports@epa.gov).
- ▶ This notice must be received by the EPA at least 30 days before the start of testing.

PAUL HODGES R&D ENG MANAGER  
Print Name and Title of Authorized Official

  
Signature

27 FEB 2019  
Date

**Remarks:**

**v1**



UNITED STATES ENVIRONMENTAL PROTECTION AGENCY  
RESEARCH TRIANGLE PARK, NC 27711

FEB 28 2018

Mr. Justin White  
Hearthstone QHPP, Inc.  
#17 Stafford Ave.  
Morrisville, VT 05661

OFFICE OF  
AIR QUALITY PLANNING  
AND STANDARDS

Dear Mr. White,

I am writing in response to your letter dated January 12, 2018, regarding wood heaters manufactured by Hearthstone QHPP, Inc. (Hearthstone). This response, dated February 28, 2018, supercedes our previous response (dated February 26, 2018) to correct an inaccuracy regarding required changes to ASTM E3053-17.

You are requesting to use an alternative test method, using cord wood, as referenced in section 60.532(c) of 40 CFR part 60, Subpart AAA, Standards of Performance for New Residential Wood Heaters (Subpart AAA) to meet the 2020 cord wood alternative compliance option. The 2020 cord wood alternative compliance option states that each affected wood heater manufactured or sold at retail for use in the United States on or after May 15, 2020, must not discharge into the atmosphere any gases that contain particulate matter in excess of 2.5 g/hr. Compliance must be determined by a cord wood test method approved by the Administrator along with the procedures in 40 CFR 60.534. You have requested approval to use the procedures and specifications found in ASTM Method E3053-17, a cord wood test method titled, "Standard Test Method for Determining Particulate Matter Emissions from Wood Heaters using Cordwood Test Fuel," in conjunction with ASTM E2515-11 and Canadian Standards Administration (CSA) Method CSA-B415.1-10, which are specified in 40 CFR 60.534.

We understand that Hearthstone is also requesting that the alternative method proposed above be approved to apply broadly to all wood heaters manufactured by Hearthstone meeting the requirements of Subpart AAA, from the approval date of this request until such time that Subpart AAA is revised or replaced to require a different cord wood certification method, providing all requirements of section 60.533 of Subpart AAA are met.

With the caveats set forth below, we approve your alternative test method request for certifying wood heaters using ASTM E3053-17 in conjunction with section 60.534 of Subpart AAA to meet the 2020 cord wood compliance option until such time that Subpart AAA is revised or replaced to require a different cord wood certification method. We also approve application of this alternative method to all wood heaters manufactured by Hearthstone meeting the requirements of Subpart AAA.

As required in Subpart AAA, section 60.354(d), you or your approved test laboratory must also measure the first hour of particulate matter emissions for each test run using a separate filter in one of the two parallel sampling trains. These results must be reported separately and also included in the total particulate matter emissions per run. Also, as required by Subpart AAA, section 60.534(e), you must have your approved laboratory measure the efficiency, heat output, and carbon monoxide emissions of the tested wood heater using CSA-B415.1-10. For measurement of particulate matter emission concentrations, ASTM 2515-11 must be used.

The following change to ASTM E3053-17 must be followed:

1. Coal bed conditions prior to loading test fuel. The coal bed shall be a level plane without valleys or ridges for all test runs in the high, low, and medium burn rate categories.

The following changes to ASTM E2515-11 must be followed:

1. The filter temperature must be maintained between 80 and 90 degrees F during testing.
2. Filters must be weighed in pairs to reduce weighing error propagation; see ASTM 2515-11, Section 10.2.1 Analytical Procedure.
3. Sample filters must be Pall TX-40 or equivalent Teflon-coated glass fiber, and of 47 mm, 90 mm, 100 mm, or 110 mm in diameter.
4. Only one point is allowed outside the +/- 10 percent proportionality range per test run.

A copy of this letter must be included in each certification test report where this alternative test method is utilized.

It is reasonable that this alternative test method approval be broadly applicable to all wood heaters subject to the requirements of 40 CFR part 60, Subpart AAA. For this reason, we will post this letter as ALT-125 on our website at <http://www3.epa.gov/ttn/emc/approalt.html> for use by other interested parties. As noted earlier in this letter, this alternative method approval is valid until such time that Subpart AAA is revised or replaced to require a different cord wood certification method, and at such time, this alternative will be reconsidered and possibly withdrawn.

If you have additional questions regarding this approval, please contact Michael Toney of my staff at 919-541-5247 or [toney.mike@epa.gov](mailto:toney.mike@epa.gov).

Sincerely,

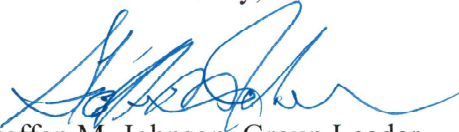

Steffan M. Johnson, Group Leader  
Measurement Technology Group

cc: Amanda Aldridge, EPA/OAQPS/OID  
Adam Baumgart-Getz, EPA/OAQPS/OID  
Rafael Sanchez, EPA/OECA  
Michael Toney, EPA/OAQPS/AQAD

**U.S. ENVIRONMENTAL PROTECTION AGENCY (EPA)  
 CERTIFICATION OF CONFORMITY  
 PURSUANT TO 40 CFR PART 60 SUBPARTS AAA AND QQQQ  
 2015 STANDARDS OF PERFORMANCE FOR NEW RESIDENTIAL WOOD HEATERS, NEW  
 RESIDENTIAL HYDRONIC HEATERS AND FORCED-AIR FURNACES**

Disclaimer: The statutory provisions and the EPA regulations described in this document contain legally binding requirements. This document is not a substitute for those provisions or regulations, nor is it a regulation itself. In the event of a discrepancy, please refer to 40 CFR PART 60 Subparts AAA AND QQQQ, Sections 60.533(b) and 60.5475(b). This document may be revised periodically without public notice. If you have additional questions, please contact Rafael Sanchez at 202-564-7028 or via email at [sanchez.rafael@epa.gov](mailto:sanchez.rafael@epa.gov).

<b>Report Number: PI-20190</b>	<b>Date of Tests: April 1<sup>st</sup> and 3<sup>rd</sup>, 2019</b>	<b>Date of Report: April 15, 2019</b>
<b>Quality Assurance Plan included?:</b> Yes <input checked="" type="checkbox"/> No <input type="checkbox"/>	<b>Wood Heater/Hydronic Heater/Forced-Air Furnace Application Included: Yes <input checked="" type="checkbox"/> No <input type="checkbox"/></b>	<b>Remarks:</b>
<b>Affected Source Data Summary</b>		
<b>Wood Burning Heater</b>	<b>Hydronic Heater</b>	<b>Forced-Air Furnace</b>
Weighted particulate emission average of 3 test runs: 1.21 grams per hour	Maximum Output Rating: _____ Weighted particulate emission average: X Lb/MMbtu output	Particulate emission average: X Lb/MMbtu output
Weighted average HHV efficiency of 3 test runs: 71.6%	Annual Efficiency Rating: _____	Overall thermal efficiency (HHV): X%
	Particle Emissions: _____	Overall Delivered Heat Efficiency: X%

**AFFIRMATIONS**

- The above-named affected source has been tested by a laboratory qualified to test and report on the emissions of this type of product under 40 CFR Part 60, Standards of Performance for New Residential Wood Heaters, New Residential Hydronic Heaters and Forced-Air Furnaces (2015 Standards).
- The Test Report No. PI-20190, prepared by Danick Power, P.Eng and dated April 15, 2019, has been reviewed by Ryan Beard C.Tech, and was found to be complete and to have used the correct procedures in accordance to the 2015 NSPS Standards.
- The emissions levels measured in the Test Report and listed above comply with the relevant particulate matter limits established by the 2015 NSPS Standards.
- The model listed above was tested to ASTM E3053-17 ; ASTM E2515-11 methods ALT-125 as referred into 40 CFR Part 60 Subpart AAA, CSA B415.1-10.
- The permanent label and owner's manual meets the requirements of 40 CFR § 60.536 and/or § 60.5478.
- The above-named manufacturer, on the effective date of this certificate, was operating under a quality assurance plan, per 40 CFR § 60.533(m) and/or § 60.5475(m), that has been reviewed and approved by Ryan Beard, C.Tech
- The above-named manufacturer has contracted CSA Group to conduct regular (at least annual) unannounced audits of the manufacturing facility, affected source, and quality assurance plan pursuant to 40 CFR § 60.533(m) and/or § 60.5475(m).

**U.S. ENVIRONMENTAL PROTECTION AGENCY (EPA)  
 CERTIFICATION OF CONFORMITY  
 PURSUANT TO 40 CFR PART 60 SUBPARTS AAA AND QQQQ  
 2015 STANDARDS OF PERFORMANCE FOR NEW RESIDENTIAL WOOD HEATERS, NEW  
 RESIDENTIAL HYDRONIC HEATERS AND FORCED-AIR FURNACES**

Disclaimer: The statutory provisions and the EPA regulations described in this document contain legally binding requirements. This document is not a substitute for those provisions or regulations, nor is it a regulation itself. In the event of a discrepancy, please refer to 40 CFR PART 60 Subparts AAA AND QQQQ, Sections 60.533(b) and 60.5475(b). This document may be revised periodically without public notice. If you have additional questions, please contact Rafael Sanchez at 202-564-7028 or via email at [sanchez.rafael@epa.gov](mailto:sanchez.rafael@epa.gov).

**GENERAL INFORMATION**

**Manufacturer's Name:** Wolf Steel Ltd

<b>Heater Type (Circle One):</b>	Adjustable Burn Rate Wood Heater	Pellet Stove	Single Burn Rate Heater	Hydronic Heater	Forced Air Furnace	Other:
<b>Hydronic Heater Type (Circle One):</b>	Traditional	Full Storage	Partial Storage	Indoor/Outdoor	Other:	
<b>Forced-Air Furnace Type (Circle One):</b>	Small (less than 65,000 BTU/hr heat output)		Large (greater than 65,000 BTU/hr heat output)		Other:	
<b>Fuel Type:</b>	Crib	Pellet	Cordwood	Other:		

**Model Name and Number:** Napoleon EPI3C, Napoleon EPI3T, Napoleon EPI3TN

**Catalyst:** Yes \_\_\_\_\_ No  \_\_\_\_\_

**Mailing Address:** 9 NAPLOEON ROAD

**Street Address:** 9 NAPLOEON ROAD

<b>City:</b> Barrie	<b>State:</b> Ont.	<b>ZIP Code:</b> L4M 0G8
<b>Phone:</b> 705-721-1212	<b>Fax:</b>	<b>Web Site:</b> WWW.NAPOLEONPRODUCTS.COM

**Address of Manufacturing Facility:** 9 NAPLOEON ROAD

<b>City:</b> Barrie	<b>State:</b> Ont.	<b>ZIP Code:</b> L4M 0G8
---------------------	--------------------	--------------------------

**EPA APPROVED THIRD PARTY CERTIFIER**

**Authorized Representative:** Ryan Beard, C.Tech.

**Company:** CSA Group

<b>Phone:</b> 416-747-2630	<b>E-mail:</b> ryan.beard@csagroup.org	<b>Fax:</b>
<b>City:</b> Toronto	<b>State:</b> Ont.	<b>ZIP Code:</b> M9W 1R3

**Position:** Certifier III

**U.S. ENVIRONMENTAL PROTECTION AGENCY (EPA)  
CERTIFICATION OF CONFORMITY  
PURSUANT TO 40 CFR PART 60 SUBPARTS AAA AND QQQQ  
2015 STANDARDS OF PERFORMANCE FOR NEW RESIDENTIAL WOOD HEATERS, NEW  
RESIDENTIAL HYDRONIC HEATERS AND FORCED-AIR FURNACES**

Disclaimer: The statutory provisions and the EPA regulations described in this document contain legally binding requirements. This document is not a substitute for those provisions or regulations, nor is it a regulation itself. In the event of a discrepancy, please refer to 40 CFR PART 60 Subparts AAA AND QQQQ, Sections 60.533(b) and 60.5475(b). This document may be revised periodically without public notice. If you have additional questions, please contact Rafael Sanchez at 202-564-7028 or via email at [sanchez.rafael@epa.gov](mailto:sanchez.rafael@epa.gov).

**Ryan Beard, C.Tech, Certifier III**  
\_\_\_\_\_  
Print Name and Title

  
\_\_\_\_\_  
Signature of Authorized Third-Party Representative

**May 24, 2019**  
\_\_\_\_\_  
Date

**This is a certification of conformity to certify that the bearer  
has successfully completed the requirements pursuant to the  
2015 NSPS Standards.**

Third-party EPA approval expiration date: **2020**  
\_\_\_\_\_

V1

Remarks:



**U.S. ENVIRONMENTAL PROTECTION AGENCY (EPA)  
 CERTIFICATION OF CONFORMITY  
 PURSUANT TO 40 CFR PART 60 SUBPARTS AAA AND QQQQ  
 2015 STANDARDS OF PERFORMANCE FOR NEW RESIDENTIAL WOOD HEATERS, NEW  
 RESIDENTIAL HYDRONIC HEATERS AND FORCED-AIR FURNACES**

**GENERAL INFORMATION**

**Manufacturer's Name: Wolf Steel ltd**

<b>Heater Type (Circle One):</b>	Adjustable Burn Rate Wood Heater	Pellet Stove	Single Burn Rate Heater	Hydronic Heater	Forced Air Furnace	Other:
<b>Hydronic Heater Type (Circle One):</b>	Traditional	Full Storage	Partial Storage	Indoor/Outdoor	Other:	
<b>Forced-Air Furnace Type (Circle One):</b>	Small (less than 65,000 BTU/hr heat output)		Large (greater than 65,000 BTU/hr heat output)		Other:	
<b>Fuel Type:</b>	Crib	Pellet	Cordwood	Other:		

**Model Name and Number: Napoleon EPI3C, Napoleon EPI3T, Napoleon EPI3TN, Timberwolf TI3C-1, Timberwolf TI3T-1, Timberwolf TI3TN-1**

**Catalyst: Yes \_\_\_\_\_ No**

**Mailing Address: 9 NAPLOEON ROAD**

**Street Address: 9 NAPLOEON ROAD**

<b>City: Barrie</b>	<b>State: Ont.</b>	<b>ZIP Code: L4M 0G8</b>
<b>Phone: 705-721-1212</b>	<b>Fax:</b>	<b>Web Site: WWW.NAPOLEONPRODUCTS.COM</b>

**Address of Manufacturing Facility: 9 NAPLOEON ROAD**

<b>City: Barrie</b>	<b>State: Ont.</b>	<b>ZIP Code: L4M 0G8</b>
---------------------	--------------------	--------------------------

**EPA APPROVED THIRD PARTY CERTIFIER**

**Authorized Representative: Ryan Beard, C.Tech.**

**Company: CSA Group**

<b>Phone: 416-747-2630</b>	<b>E-mail: ryan.beard@csagroup.org</b>	<b>Fax:</b>
<b>City: Toronto</b>	<b>State: Ont.</b>	<b>ZIP Code: M9W 1R3</b>

**U.S. ENVIRONMENTAL PROTECTION AGENCY (EPA)  
 CERTIFICATION OF CONFORMITY  
 PURSUANT TO 40 CFR PART 60 SUBPARTS AAA AND QQQQ  
 2015 STANDARDS OF PERFORMANCE FOR NEW RESIDENTIAL WOOD HEATERS, NEW  
 RESIDENTIAL HYDRONIC HEATERS AND FORCED-AIR FURNACES**

**Position: Certification Specialist**

<b>Report Number: PI-20190</b>	<b>Date of Tests: April 1<sup>st</sup> and 3<sup>rd</sup>, 2019</b>	<b>Date of Report: April 15, 2019</b>
--------------------------------	---	---------------------------------------

<b>Quality Assurance Plan included?: Yes <input checked="" type="checkbox"/> No <input type="checkbox"/></b>	<b>Wood Heater/Hydronic Heater/Forced-Air Furnace Application Included: Yes <input checked="" type="checkbox"/> No <input type="checkbox"/></b>	<b>Remarks:</b>
--	---	-----------------

**Affected Source Data Summary**

<b>Wood Burning Heater</b>	<b>Hydronic Heater</b>	<b>Forced-Air Furnace</b>
Weighted particulate emission average of 3 test runs: 1.21 grams per hour	Maximum Output Rating: _____ Weighted particulate emission average: X Lb/MMbtu output	Particulate emission average: X Lb/MMbtu output
Weighted average HHV efficiency of 3 test runs: 71.6%	Annual Efficiency Rating: _____	Overall thermal efficiency (HHV): X%
	Particle Emissions: _____	Overall Delivered Heat Efficiency: X%

**AFFIRMATIONS**

- The above-named affected source has been tested by a laboratory qualified to test and report on the emissions of this type of product under 40 CFR Part 60, Standards of Performance for New Residential Wood Heaters, New Residential Hydronic Heaters and Forced-Air Furnaces (2015 Standards).
- The Test Report No. PI-20190, prepared by Danick Power, P.Eng and dated April 15, 2019, has been reviewed by Ryan Beard C.Tech, and was found to be complete and to have used the correct procedures in accordance to the 2015 NSPS Standards.
- The emissions levels measured in the Test Report and listed above comply with the relevant particulate matter limits established by the 2015 NSPS Standards.
- The model listed above was tested to ASTM E3053-17 ; ASTM E2515-11 methods ALT-125 as referred into 40 CFR Part 60 Subpart AAA, CSA B415.1-10.
- The permanent label and owner's manual meets the requirements of 40 CFR § 60.536 and/or § 60.5478.
- The above-named manufacturer, on the effective date of this certificate, was operating under a quality assurance plan, per 40 CFR § 60.533(m) and/or § 60.5475(m), that has been reviewed and approved by Ryan Beard, C.Tech
- The above-named manufacturer has contracted CSA Group to conduct regular (at least annual) unannounced audits of the manufacturing facility, affected source, and quality assurance plan pursuant to 40 CFR § 60.533(m) and/or § 60.5475(m).

**U.S. ENVIRONMENTAL PROTECTION AGENCY (EPA)  
CERTIFICATION OF CONFORMITY  
PURSUANT TO 40 CFR PART 60 SUBPARTS AAA AND QQQQ  
2015 STANDARDS OF PERFORMANCE FOR NEW RESIDENTIAL WOOD HEATERS, NEW  
RESIDENTIAL HYDRONIC HEATERS AND FORCED-AIR FURNACES**

**Ryan Beard, C.Tech, Certification Specialist**  
Print Name and Title

  
Signature of Authorized Third-Party Representative

**August 24, 2020**  
Date

**This is a certification of conformity to certify that the bearer  
has successfully completed the requirements pursuant to the  
2015 NSPS Standards.**

Third-party EPA approval expiration date: **2020**

V1

Remarks: