

### C-Series 2-Way Adjustable Passage Door Handle Satin Chrome

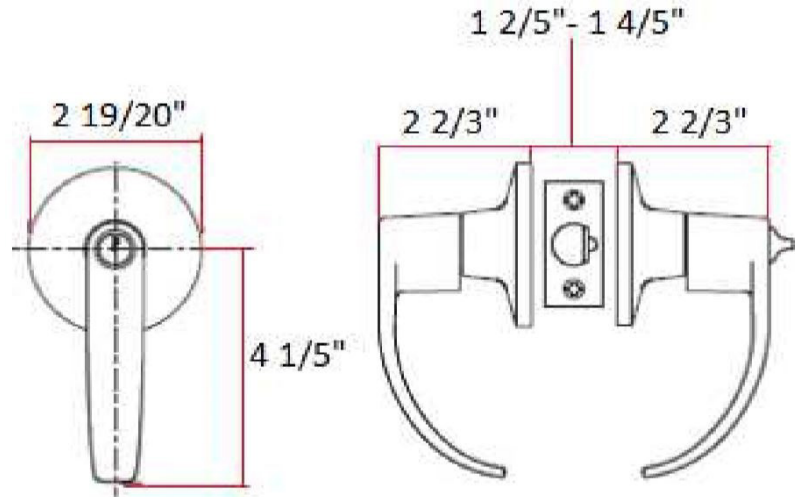

## SPECIFICATIONS

<b>MATERIAL CONSTRUCTION:</b>	Steel/Zinc	<b>KEYWAY:</b>	N/A
<b>LOCK FUNCTION:</b>	Passage	<b>REMOVABLE CORE:</b>	No
<b>DEADBOLT FUNCTION:</b>	N/A	<b>LATCH FACEPLATE I:</b>	Square Corner
<b>EXTERIOR MAX PROJECTION:</b>	2.6"	<b>LATCH BACKSET:</b>	Adj; 2-3/8" - 2-3/4"
<b>INTERIOR MAX PROJECTION:</b>	2.6"	<b>LATCH TYPE:</b>	2 Way (fixed faceplate)
<b>KOB VS. LEVER:</b>	Lever	<b>LATCHBOLT THROW DISTANCE:</b>	0.5"
<b>KNOB DIMENSIONS:</b>	N/A	<b># PINS IN CYLINDER:</b>	N/A
<b>LEVER LENGTH:</b>	4.2"	<b>ANTI-BUMP PIN INSTALLED:</b>	N/A
<b>ROSE DIMENSIONS:</b>	1.2" H x 2.95" W x 2.95" D	<b># KEYS INCLUDED:</b>	N/A
<b>ROSETTE / ESCUTCHEON SHAPE:</b>	Round	<b>SPINDLE TYPE:</b>	Square
<b>CROSS BORE:</b>	N/A	<b>MOUNTING HARDWARE INCLUDED:</b>	Yes
<b>EDGE BORE:</b>	N/A	<b>TOOLS NEEDED FOR INSTALLATION:</b>	Phillips Screwdriver
<b>HANDING:</b>	Reversible	<b>ASSEMBLED WEIGHT:</b>	2.29 lbs.
<b>REKEYABLE?:</b>	No		

<b>WARRANTY:</b>	5-Year limited warranty
<b>ANSI CERTIFICATION:</b>	Grade 2
<b>BHMA GRADE:</b>	No
<b>FIRE RATED:</b>	Yes
<b>ADA COMPLIANT:</b>	Yes



TYPE:
JOB:
ORDER CODE:
APPROVALS: