

**FLAVOR BURST® SOFT SERVE SYSTEM**

**STL-80BLD**  
**STL-80SS**

**STL-80BLD-DLX**  
**STL-80SS-DLX**

**STL-40BLD-JR**  
**STL-40SS-JR**

**STL-80BLD-INT**  
**STL-80SS-INT**
**DESCRIPTION**

Customize your soft-serve offering utilizing the Flavor Burst® system. Flavor Burst® allows you stripe or blend your soft-serve product with a variety of flavors from one spout. Create excitement by changing your offering on a weekly, monthly basis for minimal extra cost.

Easy operation that allows you to utilize a color touch panel to select your flavors and then draw your serving.

Striped flavors are applied to the outside as well as a stripe in the middle. Blended flavors mixes in the selected flavor at the spout.

The ultimate result is a fun, colorful treat filled with great-tasting premium flavors!



Every machine includes Stoelting's White Glove Service. One call does it all – customer service, technical service, parts or warranty information, installation, startup, sales, on-site service dispatch and much more. Available 24 hours a day, seven days a week year-round.

**ITEMS**

- STL-80BLD** Blended, 8 flavors, 2 wide x 4 tall cabinet
- STL-80BLD-DLX** Blended, 8 flavors, 3 wide x 3 tall cabinet
- STL-40BLD-JR** Blended, 4 flavors, 2 wide x 2 tall cabinet
- STL-80SS** Striped, 8 flavors, 2 wide x 4 tall cabinet
- STL-80SS-DLX** Striped, 8 flavors, 3 wide x 3 tall cabinet
- STL-40SS-JR** Striped, 4 flavors, 2 wide x 2 tall cabinet
- STL-80BLD-INT** Blended, 8 flavors, 3 wide x 3 tall fits inside floor stand (not included)
- STL-80SS-INT** Striped, 8 flavors, 3 wide x 3 tall fits inside floor stand (not included)

**ACCESSORIES & OPTIONS**

- 2209555** Floor stand for STL-80BLD-INT and STL-80SS-INT
- 2209616** Field installation kit (required for use with all Stoelting machines manufactured prior to June 1st, 2020)

**FEATURES**

- The Flavor Burst® system is compatible with all E, F, and O series gravity fed machines.
- Multiple configurations offered, allowing up to 8 flavors out of one spout, in striped or blended format.
- Choose from 38 syrups for Striped flavors and 17 syrups for Blended flavors, like Chocolate, Birthday Cake, Banana, Strawberry and more!
- Ability to flavor ice cream, yogurt and more.
- Concentrated syrups are stored in 1-gallon ready-to-install bags, have a long shelf life and do not require refrigeration.
- Each 1-gallon syrup bag provides 560 – 5 oz servings for Striped flavors and 400 – 5 oz servings for Blended flavors.
- The Spout Assembly installs directly onto your Stoelting freezer's spout.
- Easy to connect and disconnect syrup lines.
- The external/internal sanitizer tank allows for simple clean-in-place sanitation of the spout, syrup lines, pumps, and bag connectors.
- System is controlled by a Color Touch Panel [CTP] which is 10", full color, and high resolution.
- The program is customizable allowing you to create your own experience by adjusting pricing, advertising, icons, etc.



*Continuous research leads to ongoing product improvements; therefore, these specifications are subject to change without notice and should not be used as installation specifications.*

Approvals

Date

--	--

# FLAVOR BURST® SOFT SERVE SYSTEM

## DIMENSIONS

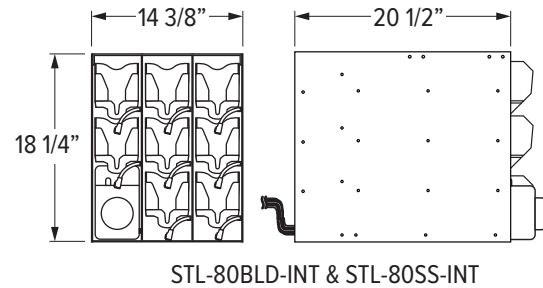
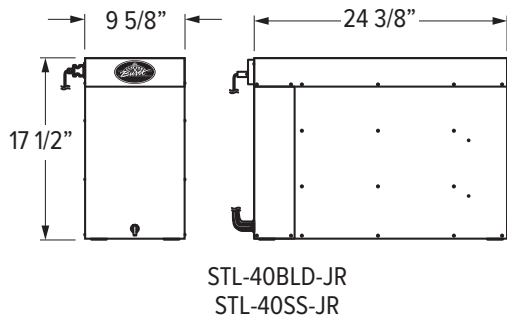
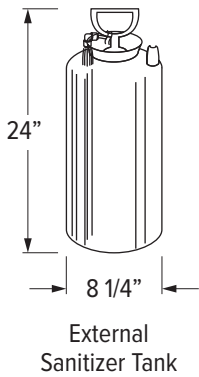
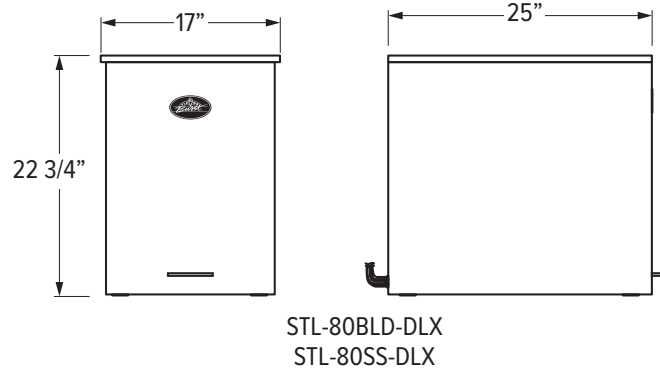
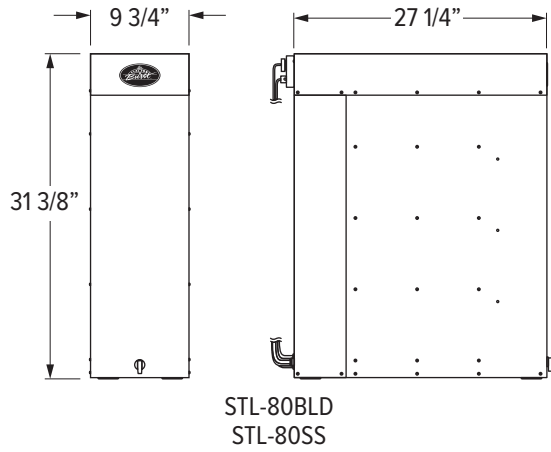

Dimensions are of Flavor Burst® unit.  
See below for floor stand dimensions

## GENERAL SPECIFICATIONS

Model Number	Flavor Burst® Style	Flavors	Flavor Tank Configuration (width x height)	Sanitizer Tank		Cord with Plug (Included)
				Capacity gallons (liters)	Location	
STL-80BLD	Blended	8	2 x 4	3 (11.4)	External	NEMA 5-15P
STL-80BLD-DLX	Blended	8	3 x 3	2 (7.6)	Internal	NEMA 5-15P
STL-40BLD-JR	Blended	4	2 x 2	2 (7.6)	External	NEMA 5-15P
STL-80SS	Striped	8	2 x 4	3 (11.4)	External	NEMA 5-15P
STL-80SS-DLX	Striped	8	3 x 3	2 (7.6)	Internal	NEMA 5-15P
STL-40SS-JR	Striped	4	2 x 2	2 (7.6)	External	NEMA 5-15P
STL-80BLD-INT	Blended	8	3 x 3	2 (7.6)	Internal	NEMA 5-15P
STL-80SS-INT	Striped	8	3 x 3	2 (7.6)	Internal	NEMA 5-15P

- Indoor use only.
- Floor stand dimensions for STL-80BLD-INT and STL-80SS-INT: 22-1/4" W x 29-1/2" D x 30-7/8" H



**Service Information**  
800-319-9549 (U.S. Toll Free)  
920-894-2293 (Outside the U.S.)  
www.stoeltingfoodservice.com  
www.vollrath.com