

# INSTRUCTION MANUAL

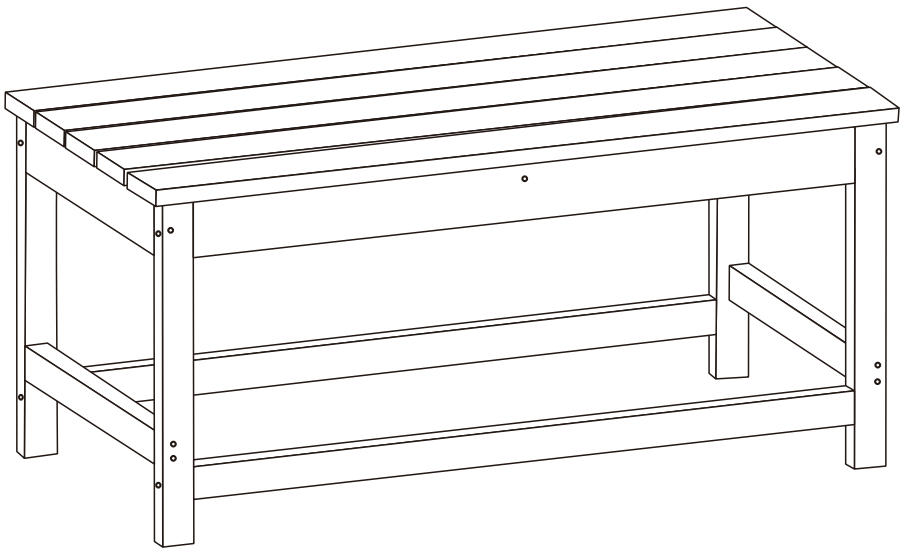

**Outdoor Poly Adirondack Coffee Table**  
**SKU: 2001-CT**

## ! NOTICE

### Do not overtighten screws. (Insert all screws before tighten screws.)

- Please do not exceed the weight limitations of this item.
- Do not stand on or use any part of this item as a step ladder.
- Firmly secure all bolts, screws and nuts before use.
- Reconfirm that all bolts, screws, and nuts are secure every 90 days.
- Do not use or store this item in the proximity of open flame or flammable/combustible chemicals.
- Avoid using strong power tool for avoiding to crack the PE board when assembling.

## TOOLS REQUIRED



PHILLIPS SCREWDRIVER  
(PROVIDED)



TABLE  
220 LBS  
CAPACITY



1 PERSON  
ASSEMBLY



UP TO 20 MIN.  
ASSEMBLY

## HARDWARE

1

M4x45mm  
SCREW

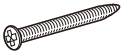

12 PCS

2

PHILLIPS  
SCREWDRIVER



1 PC

## PARTS

A

TABLE TOP

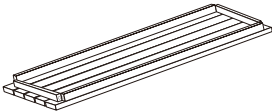

1 PC

B

TABLE LEG

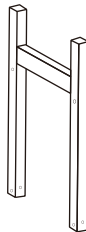

2 PCS

C

WOODEN BRACE

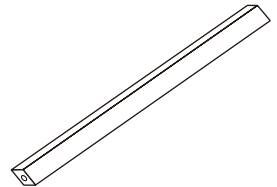

2 PCS

## PRODUCT ASSEMBLY

1

Attach part B Table Leg to part A Table Top with 4 PCS of part 1 screw using a phillips screwdriver.

Do not tighten screws too much at this stage.

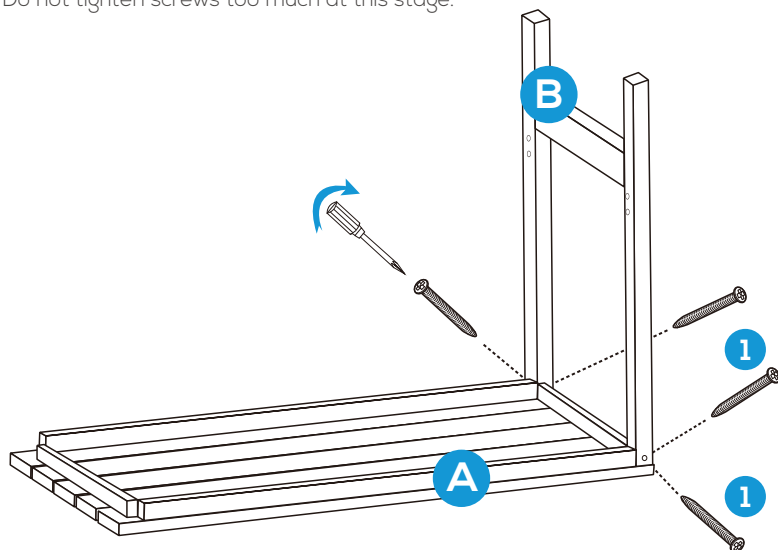

2

Attach part C Table Wooden Braces to part B Chair Leg with 2 PCS of part 1 screw.

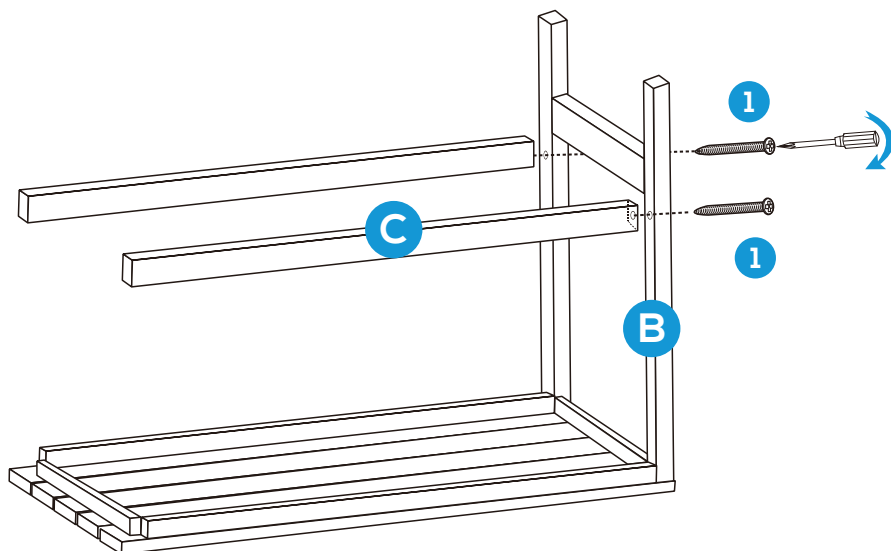

## PRODUCT ASSEMBLY

3

Attach another part B Table Leg to part A Table Top and part C Wooden brace with 6 PCS of part I screw using a phillips screwdriver.

