

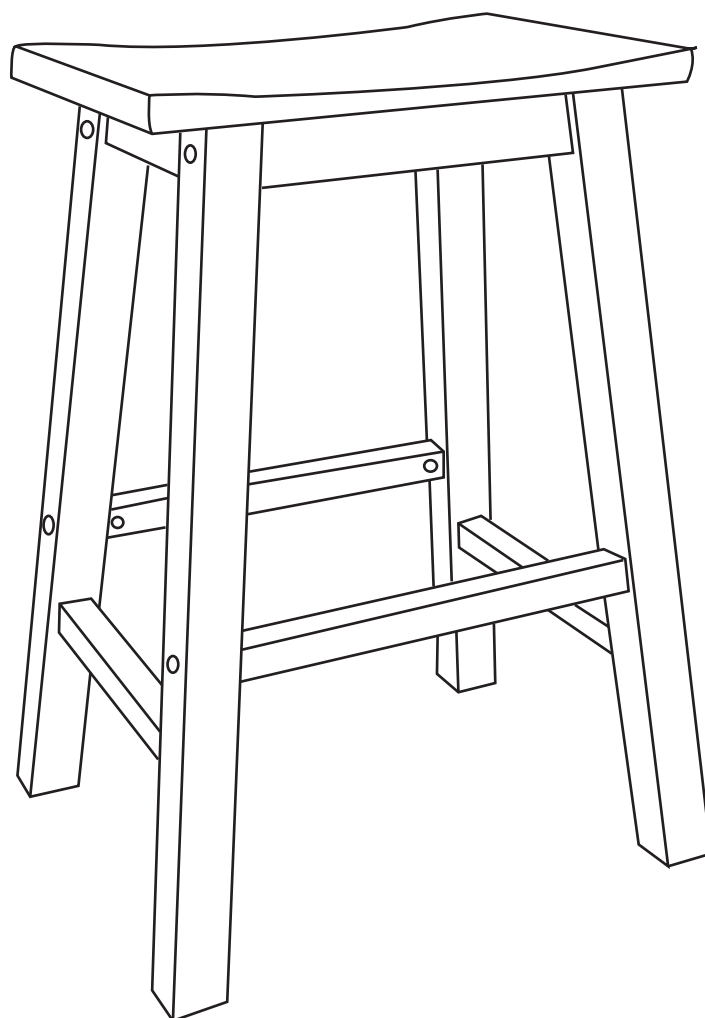

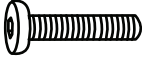

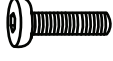



29" Solid Wood Counter Stool



Hardware:

1	 M6x45MM	Screws	8pcs
2	 M6x30MM	Screws	2pcs
3	 M6	Allen key	1pc
4		Cap	8pcs

Parts list:

A		Seat	1pc
B		Legs	1pc
C		Legs	1pc
D		Footrest	2pcs
E		Batten	2pcs
F		Batten	1pc

Step 1

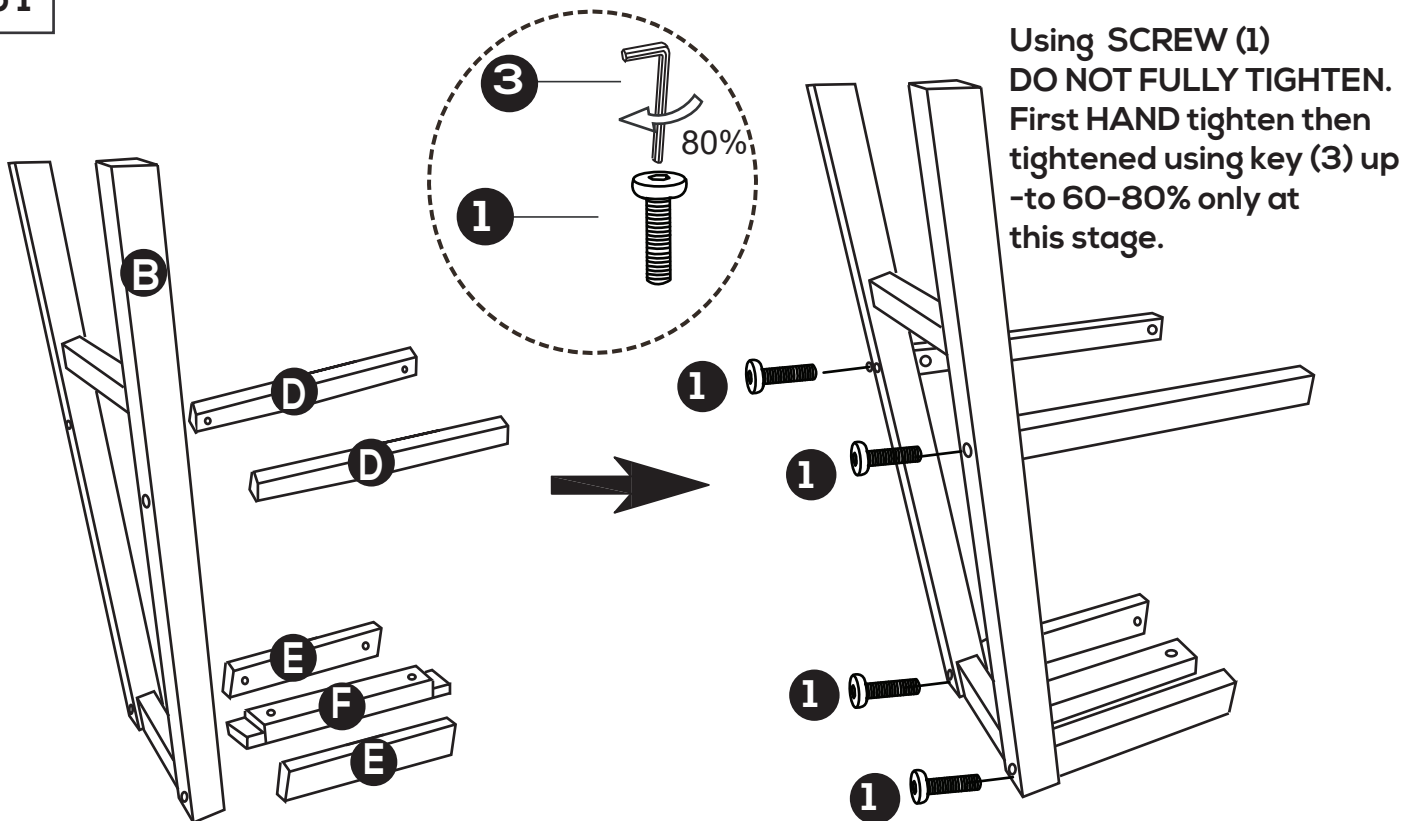

Put chair back on a clean flat surface.
Please note put the legs on correct hole site as shown in the diagram

Step 2

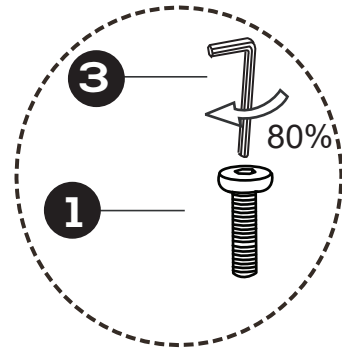
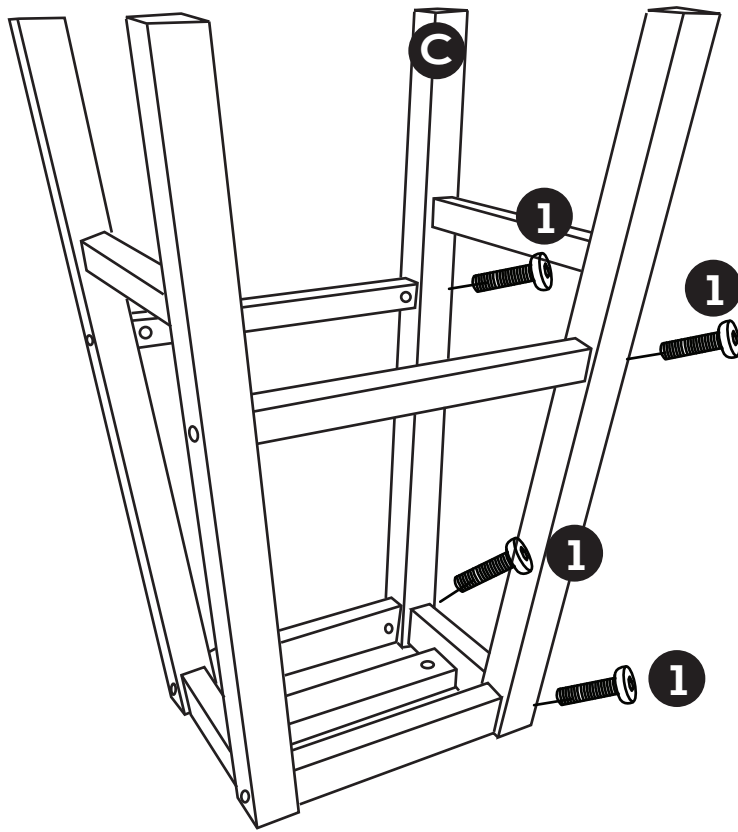

Using SCREW (1)

DO NOT FULLY TIGHTEN.

First HAND tighten then tightened using key (3) up-to 60-80% only at this stage.

Step 3

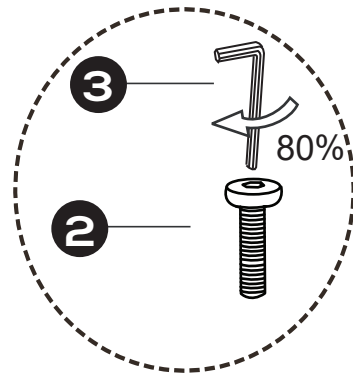
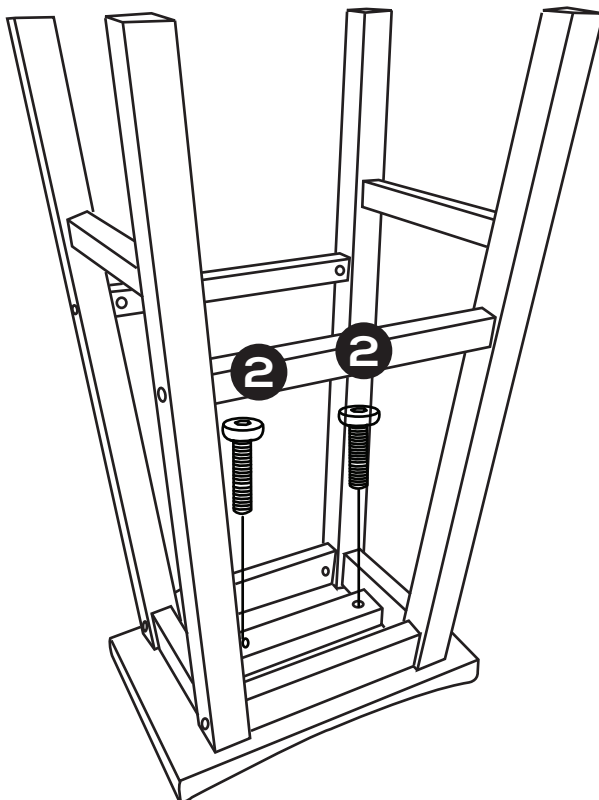

Using SCREW (2)

DO NOT FULLY TIGHTEN.

First HAND tighten then tightened using key (3) up-to 60-80% only at this stage.

Step 4

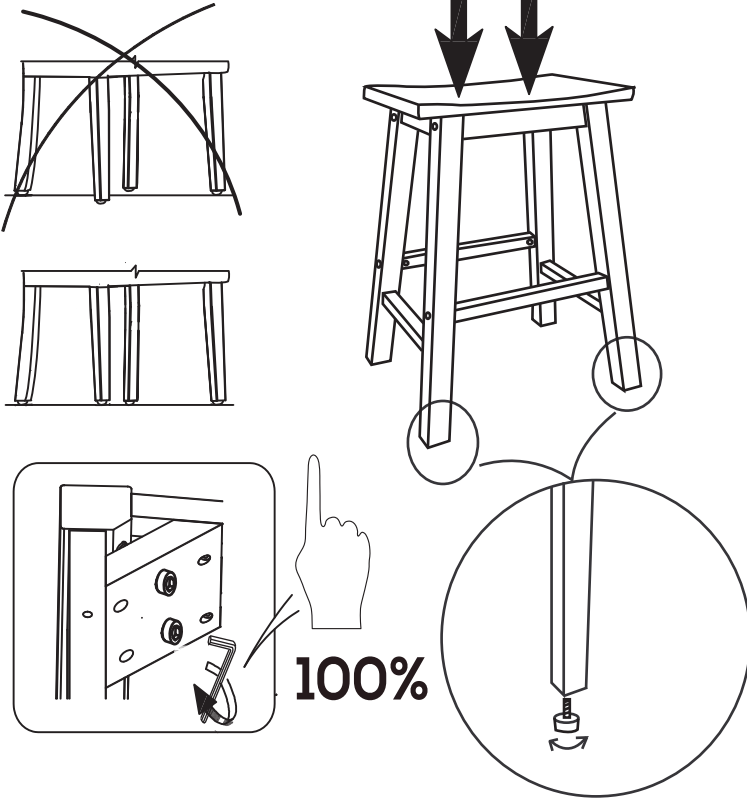

Put chair in the upright position and **SIT ON THE CHAIR** to press downwards on the seat pad ensuring that all 4 feet touch the ground and chair is leveled.

Proceed to tighten all screws making sure the chair remains level when tightening.

Check that all screws are tight on a regular basis to ensure chair remains level and secure.

Also you can using adjustable feet to keep four legs level .

Step 5

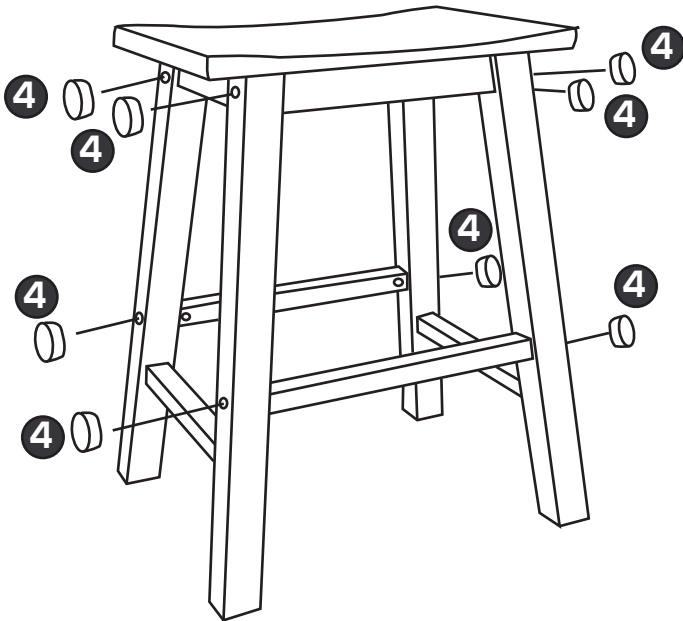

Put the caps in the legs hole

Step 6

