

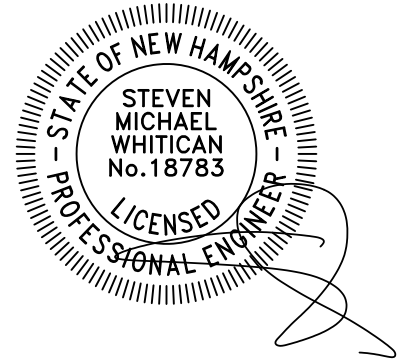

January 30, 2025

**To:** Whom it may concern,  
**From:** Building Drops, Inc.  
**On behalf of:** Glass Warehouse LLC / Future Glass  
1319 Rocky Point Drive, Suite 200  
Oceanside, CA 92056  
**Report:** PER 9164  
**Subject:** RAN-CHRES Base Shoe System



**Scope:**

The purpose of this report is to evaluate the performance of the RAN-CHRES Base Shoe System manufactured by Glass Warehouse LLC / Future Glass. The conditions in this report meet all the applicable requirements of the current International Building Code. Glass thicknesses and properties were extracted from ASTM E1300. Steel members and connections were designed according to AISC Design Guides. ICC Acceptance Criteria AC439 and ASTM E2358 were used for determining applicable design criteria for railing systems. A summary of standards can be found on the following pages.

Only rectangular glass is covered within this report, different glass shapes do not apply to this analysis. Gaskets may be modified according to different glass thicknesses as long as thickness is specified in this analysis.

The glass balustrade system uses a stainless steel base shoe to support the glass lights specified herein. The glass base shoe system has been designed for the following loading conditions:

- 200 lb concentrated load at the top of glass or at the top rail
- 50 lbs linear load applied at the top of glass or at the top rail
- Allowable wind load as shown on the tables within this report

This report provides glass thicknesses the base shoe has been designed to support. Other glass thicknesses may be used but are outside of the scope of this report.

**Instructions for Use**

1. Determine jobsite wind load using table 1.
2. Select desired glass composition from tables 3, 4, 5, 6, 7, 8, 9, 10, 11, and 12.
3. Determine max. glass size based on wind load requirements using table 1 for reference.
4. Using table 15, choose desired anchor type and verify allowable wind load is greater than the glass allowable wind load.

**RAN-CHRES Base Shoe System**

Project Description: Glass Warehouse LLC / Future Glass RAN-CHRES Base Shoe Engineering Analysis	Date: January 30, 2025	Customer: Glass Warehouse LLC / Future Glass	
		Project #: EEV-24-0207	
	Engineer: SH	PER: 9164	Page #: Page 1 of 28

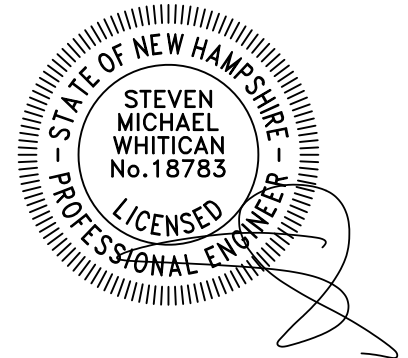
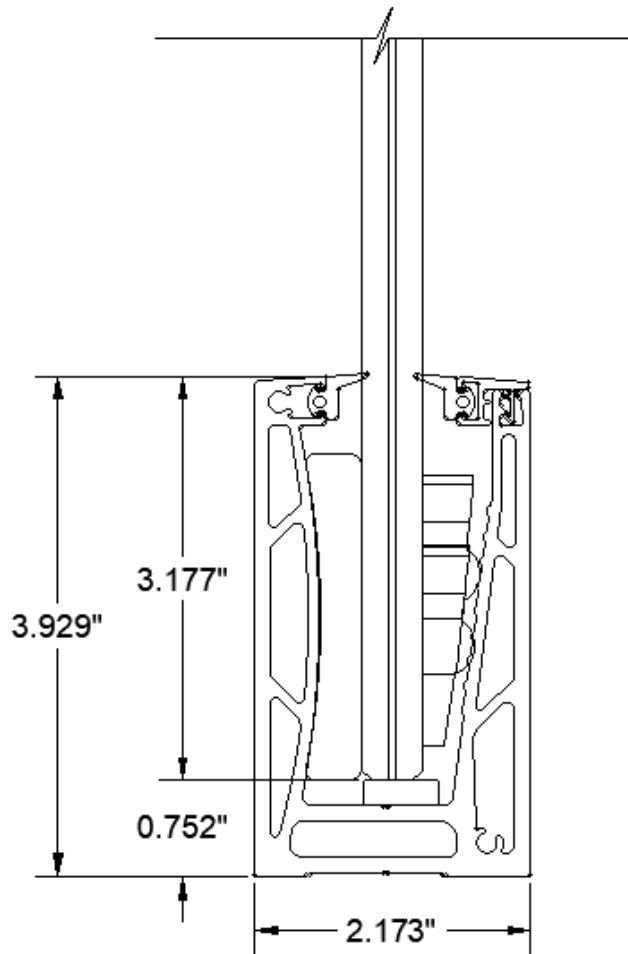

**Standards/Referenced Publications**

ASTM E1300	IBC 1607.8.1	ICC AC439
ASTM E2358	AISC Design Guides	ASTM C1048-97b
CPSC 16 CFR 1201	ANSI Z97.1	AAMA CW-12-84, Structural Properties for glass
AISC Design Guide 27	IBC 2407.1.1	NDS 2018
ASTM E6.2.1.1	SEI/ASCE 8-02	

**Limits of Use:**

Project Description: Glass Warehouse LLC / Future Glass RAN-CHRES Base Shoe Engineering Analysis	Date: January 30, 2025	Customer: Glass Warehouse LLC / Future Glass	
	Engineer: SH	Project #: EEV-24-0207	
		PER: 9164	Page #: Page 2 of 28



1. This product has been evaluated and is in compliance with the 2015, 2018, and 2021 editions of the International Building Code.
2. Product installation shall be as listed herein. Site conditions that deviate from those specified shall require further engineering analysis by a licensed engineer or registered architect.
3. When used in areas requiring wind borne debris protection this product complies with chapter 16 of the 2015, 2018, and 2021 editions of the International Building Code and does require an impact resistant covering in areas requiring impact resistance.

**Conclusion:**

In my professional opinion, the RAN-CHRES Base Shoe System manufactured by Glass Warehouse LLC / Future Glass is adequate for use under the limitations provided within this report.

I trust that this will satisfy your needs, however, feel free to call if you have any questions.

***Certification of Independence:** Please note that I do not have nor will I acquire a financial interest in any company manufacturing or distributing the product(s) for which this report is being issued. Also, I do not have nor will I acquire a financial interest in any other entity involved in the approval process of the listed product(s).*

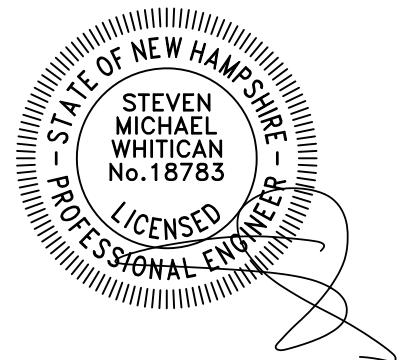

Project Description: Glass Warehouse LLC / Future Glass RAN-CHRES Base Shoe Engineering Analysis	Date: January 30, 2025	Customer: Glass Warehouse LLC / Future Glass	
		Project #: EEV-24-0207	
	Engineer: SH	PER: 9164	Page #: Page 3 of 28

**Analysis and Findings**

Under the appropriate load conditions for the system, the main load cases are summarized below:

Loading:

Horizontal Load to Base Shoe:  $25 \text{ psf} * H$  or  $W_L * H$

Balustrade Moments:  $M_i = 25 \text{ psf} * H^2/2$  or  $W_L * H^2/2$

For Top Rails:  
 $M_C = 200 \text{ lbs} * H$   
 $M_U = 50 \text{ plf} * H$

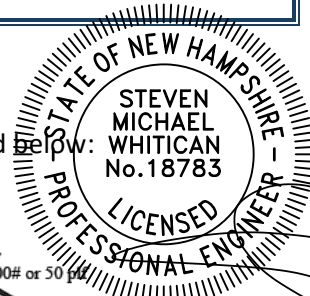
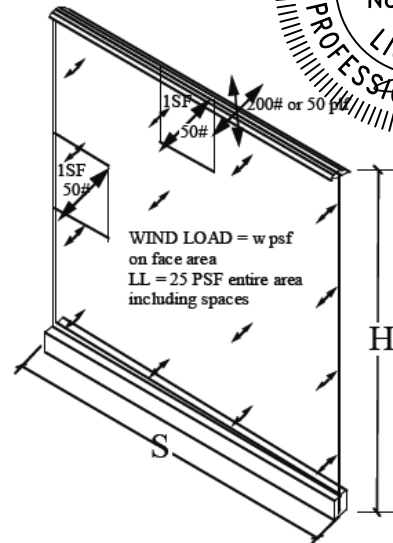

**Wind Loads on Fences or Guards**

The wind load table below has been calculated in accordance with ASCE 7-22 section 29.4, Design Wind Loads on Solid Freestanding Wall and Solid Signs. This section is applicable for free standing building guard rails, wind walls, and balcony railings that return to building walls.

Table 1: Wind Loads on Fences or Guards

Wind Loads (PSF)						
Wind Speed (mph)	$W_{ASD}$ for $C_f = 1.3$			$W_{ASD}$ for $C_f = 2.6$		
	Exp. B $K_z = 0.7$	Exp. C $K_z = 0.85$	Exp. D $K_z = 1.03$	Exp. B $K_z = 0.7$	Exp. C $K_z = 0.85$	Exp. D $K_z = 1.03$
100	9.50	11.53	13.98	19.00	23.07	27.95
110	11.49	13.95	16.91	22.98	27.91	33.82
120	13.68	16.61	20.12	27.35	33.21	40.25
130	16.05	19.49	23.62	32.10	38.98	47.24
140	18.62	22.60	27.39	37.23	45.21	54.78
150	21.37	25.95	31.44	42.74	51.90	62.89
160	24.31	29.52	35.78	48.63	59.05	71.55
170	27.45	33.33	40.39	54.90	66.66	80.78
180	30.77	37.37	45.28	61.54	74.73	90.56

Refer to the appendix of this report for detailed wind load calculations.

Project Description: Glass Warehouse LLC / Future Glass RAN-CHRES Base Shoe Engineering Analysis	Date: January 30, 2025	Customer: Glass Warehouse LLC / Future Glass	
	Engineer: SH	Project #: EEV-24-0207	
		PER: 9164	Page #: Page 4 of 28



YOU ENVISION IT – WE ENGINEER IT

1900 NE Miami Ct., Ste. 2-15  
 Miami, FL 33132  
 TEL: 954.399-8478 | FAX: 954.744.4738  
 WEB: [www.buildingdrops.com](http://www.buildingdrops.com)

**Glass Strength**

**Table 2: Glass properties extracted from ASTM E1300**

Glass properties				
Glass types	Modulus of rupture, psi	All. Bending Stress, psi	All. Compressive Stress, psi	All. Glass Stress per ASTM E1300, psi
Tempered	24000	6000	6000	10600
Heat Strengthened	12000	3000	3000	5300
Annealed	6000	1500	1500	2900

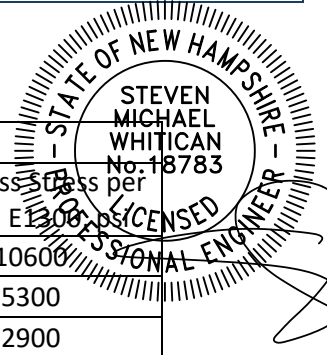

**Allowable Wind Load Table for Monolithic Glass**

**Table 3: 1/2" Monolithic Tempered Glass**

Allowable Wind Pressure (PSF)						
Glass Width (in.)	Glass Height (in.)					
	36	39.75	42	48	60	72
12	59.67	48.52	42.92	31.76	19.77	11.15
24	48.25	39.14	34.71	25.78	16.09	9.05
36	39.64	32.38	28.70	21.36	13.36	7.61
42	*	*	25.24	18.85	11.80	6.72
48	*	*	*	16.56	10.41	5.88
60	*	*	*	*	8.51	4.86
72	*	*	*	*	*	4.09

\*Note: Allowable wind load is the same as last value in the column.

**Allowable Wind Load Tables for Laminated Glass**

**Table 4: 7/16" O.A. Laminated Glass: 3/16" Tempered Glass – 0.060" PVB – 3/16" Tempered Glass**

Allowable Wind Pressure (PSF)									
Glass Width (in.)	Effective Thickness		Allowable Moment (lb-in/ft)	Glass Height (in.)					
	Deflection	Stress		36	39.75	42	48	60	72
12	0.234	0.264	1472	24.78	20.33	18.21	13.94	8.92	6.20
24	0.252	0.285	1724	29.02	23.80	21.32	16.32	10.45	7.25
36	0.274	0.310	2038	34.31	28.14	25.20	19.30	12.35	8.58
42	0.285	0.322	2194	*	*	27.14	20.78	13.30	9.23
48	0.296	0.332	2342	*	*	*	22.18	14.19	9.86
60	0.316	0.350	2602	*	*	*	*	15.77	10.95
72	0.332	0.364	2813	*	*	*	*	*	11.84

\*Note: Allowable wind load is the same as last value in the column.

Project Description: Glass Warehouse LLC / Future Glass RAN-CHRES Base Shoe Engineering Analysis	Date: January 30, 2025	Customer: Glass Warehouse LLC / Future Glass	
	Engineer: SH	Project #: EEV-24-0207	
		PER: 9164	Page #: Page 5 of 28



**Table 5: 7/16" O.A. Laminated Glass: 3/16" Tempered Glass – 0.060" PVB Stiff – 3/16" Tempered Glass**

Glass Width (in.)	Effective Thickness		Allowable Moment (lb-in/ft)	Glass Height (in.)					
	Deflection	Stress		36	39.75	42	48	60	72
12	0.249	0.282	1687	28.41	23.30	20.87	15.98	10.23	7.10
24	0.291	0.327	2270	38.22	31.35	28.08	21.50	13.76	9.55
36	0.327	0.360	2740	46.14	37.84	33.90	25.95	16.61	11.53
42	0.340	0.371	2912	*	*	36.01	27.57	17.65	12.25
48	0.352	0.379	3048	*	*	*	28.86	18.47	12.83
60	0.369	0.391	3242	*	*	*	*	19.65	13.65
72	0.381	0.399	3368	*	*	*	*	*	14.18

\*Note: Allowable wind load is the same as last value in the column.

**Table 6: 7/16" O.A. Laminated Glass: 3/16" Tempered Glass – 0.060" SentryGlas – 3/16" Tempered Glass**

Glass Width (in.)	Effective Thickness		Allowable Moment (lb-in/ft)	Glass Height (in.)					
	Deflection	Stress		36	39.75	42	48	60	72
12	0.313	0.348	2564	43.16	35.40	31.71	24.28	15.54	10.79
24	0.371	0.392	3266	54.98	45.09	40.39	30.93	19.79	13.74
36	0.394	0.406	3498	58.88	48.30	43.26	33.12	21.20	14.72
42	0.400	0.409	3554	*	*	43.96	33.66	21.54	14.96
48	0.404	0.412	3593	*	*	*	34.02	21.78	15.12
60	0.409	0.414	3640	*	*	*	*	22.06	15.32
72	0.412	0.416	3666	*	*	*	*	*	15.43

\*Note: Allowable wind load is the same as last value in the column.

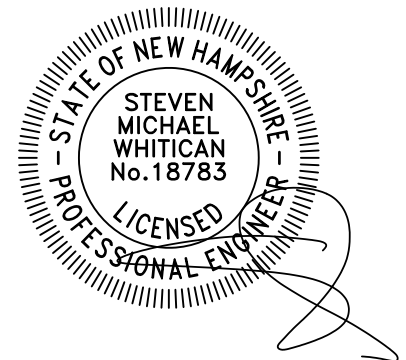

Project Description: Glass Warehouse LLC / Future Glass RAN-CHRES Base Shoe Engineering Analysis	Date: January 30, 2025	Customer: Glass Warehouse LLC / Future Glass	
	Engineer: SH	Project #: EEV-24-0207	
	PER: 9164	Page #: Page 6 of 28	



**Table 7: 9/16" O.A. Laminated Glass: 1/4" Tempered Glass – 0.090" PVB – 1/4" Tempered Glass**

Glass Width (in.)	Effective Thickness		Allowable Moment (lb-in/ft)	Glass Height (in.)					
	Deflection	Stress		36	39.75	42	48	60	72
12	0.283	0.318	2142	36.06	29.58	26.49	20.29	12.98	9.02
24	0.300	0.338	2428	40.87	33.52	30.03	22.99	14.71	10.22
36	0.322	0.364	2803	47.18	38.70	34.67	26.54	16.99	11.80
42	0.334	0.376	2997	*	*	37.07	28.38	18.17	12.61
48	0.345	0.388	3186	*	*	*	30.17	19.31	13.41
60	0.367	0.408	3533	*	*	*	*	21.41	14.87
72	0.386	0.425	3825	*	*	*	*	*	16.10

\*Note: Allowable wind load is the same as last value in the column.

**Table 8: 9/16" O.A. Laminated Glass: 1/4" Tempered Glass – 0.090" PVB Stiff – 1/4" Tempered Glass**

Glass Width (in.)	Effective Thickness		Allowable Moment (lb-in/ft)	Glass Height (in.)					
	Deflection	Stress		36	39.75	42	48	60	72
12	0.297	0.335	2386	40.17	32.95	29.51	22.59	14.46	10.04
24	0.340	0.382	3094	52.09	42.73	38.27	29.30	18.75	13.02
36	0.379	0.419	3723	62.68	51.41	46.05	35.26	22.56	15.67
42	0.395	0.433	3966	*	*	49.06	37.56	24.04	16.69
48	0.409	0.443	4166	*	*	*	39.45	25.25	17.53
60	0.431	0.459	4460	*	*	*	*	27.03	18.77
72	0.446	0.469	4657	*	*	*	*	*	19.60

\*Note: Allowable wind load is the same as last value in the column.

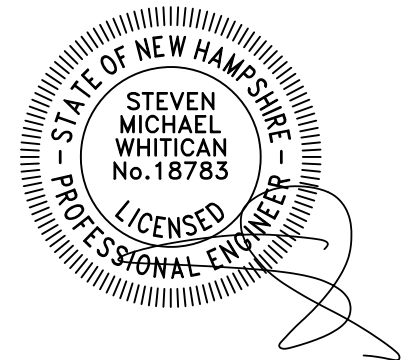

Project Description: Glass Warehouse LLC / Future Glass RAN-CHRES Base Shoe Engineering Analysis	Date: January 30, 2025	Customer: Glass Warehouse LLC / Future Glass	
	Engineer: SH	Project #: EEV-24-0207	
	PER: 9164	Page #: Page 7 of 28	



**Table 9: 9/16" O.A. Laminated Glass: 1/4" Tempered Glass – 0.090" SentryGlas – 1/4" Tempered Glass**

Glass Width (in.)	Effective Thickness		Allowable Moment (lb-in/ft)	Glass Height (in.)					
	Deflection	Stress		36	39.75	42	48	60	72
12	0.364	0.405	3480	58.59	48.06	43.05	32.96	21.09	14.65
24	0.433	0.461	4496	75.69	62.08	55.61	42.58	27.25	18.92
36	0.463	0.479	4864	81.89	67.17	60.16	46.06	29.48	20.47
42	0.471	0.484	4957	*	*	61.31	46.94	30.04	20.86
48	0.476	0.487	5020	*	*	*	47.54	30.43	21.13
60	0.484	0.490	5099	*	*	*	*	30.90	21.46
72	0.488	0.493	5143	*	*	*	*	*	21.65

\*Note: Allowable wind load is the same as last value in the column.

**Table 10: 11/16" O.A. Laminated Glass: 5/16" Tempered Glass – 0.090" PVB – 5/16" Tempered Glass**

Glass Width (in.)	Effective Thickness		Allowable Moment (lb-in/ft)	Glass Height (in.)					
	Deflection	Stress		36	39.75	42	48	60	72
12	0.374	0.420	3743	63.02	51.69	46.30	35.45	22.69	15.75
24	0.390	0.439	4092	68.89	56.51	50.62	38.75	24.80	17.22
36	0.413	0.465	4578	77.07	63.21	56.62	43.35	27.74	19.27
42	0.425	0.478	4843	*	*	59.90	45.86	29.35	20.38
48	0.437	0.491	5110	*	*	*	48.39	30.97	21.51
60	0.462	0.515	5624	*	*	*	*	34.09	23.67
72	0.484	0.536	6086	*	*	*	*	*	25.61

\*Note: Allowable wind load is the same as last value in the column.

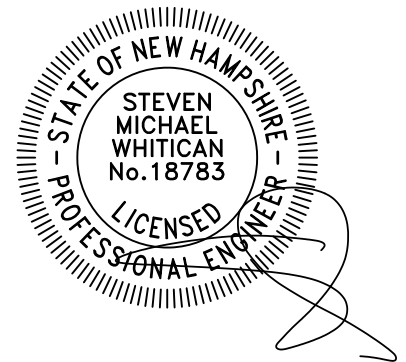

Project Description: Glass Warehouse LLC / Future Glass RAN-CHRES Base Shoe Engineering Analysis	Date: January 30, 2025	Customer: Glass Warehouse LLC / Future Glass	
	Engineer: SH	Project #: EEV-24-0207	
		PER: 9164	Page #: Page 8 of 28

**Table 11: 11/16" O.A. Laminated Glass: 5/16" Tempered Glass – 0.090" PVB ES – 5/16" Tempered Glass**

Glass Width (in.)	Effective Thickness		Allowable Moment (lb-in/ft)	Glass Height (in.)					
	Deflection	Stress		36	39.75	42	48	60	72
12	0.388	0.437	4040	68.01	55.79	49.97	38.26	24.49	17.00
24	0.431	0.485	4979	83.81	68.75	61.58	47.14	30.17	20.95
36	0.476	0.529	5922	99.70	81.78	73.25	56.08	35.89	24.93
42	0.496	0.546	6320	*	*	78.16	59.84	38.30	26.60
48	0.513	0.560	6660	*	*	*	63.07	40.36	28.03
60	0.542	0.582	7189	*	*	*	*	43.57	30.26
72	0.563	0.597	7561	*	*	*	*	*	31.82

\*Note: Allowable wind load is the same as last value in the column.

**Table 12: 11/16" O.A. Laminated Glass: 5/16" Tempered Glass – 0.090" SentryGlas – 5/16" Tempered Glass**

Glass Width (in.)	Effective Thickness		Allowable Moment (lb-in/ft)	Glass Height (in.)					
	Deflection	Stress		36	39.75	42	48	60	72
12	0.458	0.511	5544	93.34	76.56	68.57	52.50	33.60	23.33
24	0.546	0.585	7256	122.15	100.19	89.75	68.71	43.98	30.54
36	0.588	0.613	7972	134.21	110.08	98.60	75.49	48.31	33.55
42	0.600	0.620	8162	*	*	100.95	77.29	49.46	34.35
48	0.609	0.625	8294	*	*	*	78.54	50.27	34.91
60	0.620	0.632	8460	*	*	*	*	51.27	35.60
72	0.627	0.635	8555	*	*	*	*	*	36.00

\*Note: Allowable wind load is the same as last value in the column.

Refer to the appendix of this report for detailed glass capacity calculations.

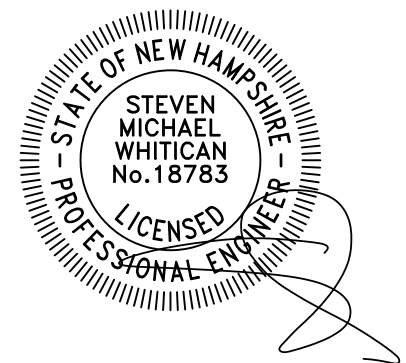

Project Description: Glass Warehouse LLC / Future Glass RAN-CHRES Base Shoe Engineering Analysis	Date: January 30, 2025	Customer: Glass Warehouse LLC / Future Glass	
	Engineer: SH	Project #: EEV-24-0207	
		PER: 9164	Page #: Page 9 of 28



**Glass Height based on 1" Deflection Limitation**

**Table 13: 7/16" O.A. Laminated Glass**

Max. Glass Height (in.)						
Light Width (in)	50plf PVB	50plf PVB ES	50plf SGP	200lb PVB	200lb PVB ES	200lb SGP
12	22.52	24.11	29.72	12.09	12.87	15.58
24	24.37	27.96	33.54	17.00	19.41	23.08
36	26.49	30.72	34.71	21.36	24.67	27.77
42	27.49	31.67	34.99	23.39	26.86	29.60
48	28.40	32.40	35.18	25.32	28.81	31.22
60	29.94	33.42	35.41	28.84	32.13	34.01
72	31.13	34.06	35.54	31.93	34.90	36.38

**Table 14: 9/16" O.A. Laminated Glass**

Max. Glass Height (in.)						
Light Width (in)	50plf PVB	50plf PVB ES	50plf SGP	200lb PVB	200lb PVB ES	200lb SGP
12	27.16	28.67	34.62	14.36	15.08	17.84
24	28.92	32.65	39.35	20.04	22.50	26.85
36	31.07	35.81	40.93	24.94	28.62	32.55
42	32.13	36.96	41.32	27.24	31.22	34.77
48	33.13	37.88	41.58	29.44	33.55	36.73
60	34.88	39.19	41.91	33.51	37.56	40.10
72	36.30	40.05	42.09	37.15	40.92	42.96

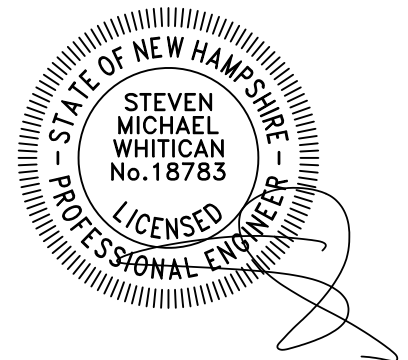

Project Description: Glass Warehouse LLC / Future Glass RAN-CHRES Base Shoe Engineering Analysis	Date: January 30, 2025	Customer: Glass Warehouse LLC / Future Glass	
	Engineer: SH	Project #: EEV-24-0207	
		PER: 9164	Page #: Page 10 of 28



**RAN-CHRES Base Shoe Installation**

**Anchor Schedule**

Anchor Schedule					
Substrate	Anchor Type	Min. Embedment (in.)	Min. Edge Distance (in.)	On Center Spacing (in.)	Allowable Moment (in-lb)
Wood SG = 0.55 min.	1/2" ASTM F593 Bolt	3.00	0.75	9.84	5810.03
	3/8" Lag Screw	3.00	0.75	9.84	1295.53
	1/2" Lag Screw	3.00	0.75	9.84	1609.13
Concrete 4000 PSI min.	3/8" Dewalt Screw-Bolt+	4.50	2.50	9.84	2658.31
	1/2" Dewalt Screw-Bolt+	4.50	2.50	9.84	3307.69
	3/8" ITW RedHead Dynabolt	1.50	2.50	9.84	841.78
	1/2" ITW RedHead Dynabolt	1.875	2.50	9.84	1194.59
	3/8" Hilti HIT-Z Rod with HIT-HY 200 Adhesive	4.50	2.375	9.84	1403.51
	1/2" Hilti HIT-Z Rod with HIT-HY 200 Adhesive	4.50	2.625	9.84	1810.37
Steel 1/4" Thk. Min.	3/8" HWH Self-Tapping Screw	Min. 3 threads penetration past steel structure	0.50	9.84	1672.71
	1/2" HWH Self-Tapping Screw	Min. 3 threads penetration past steel structure	0.50	9.84	2229.55

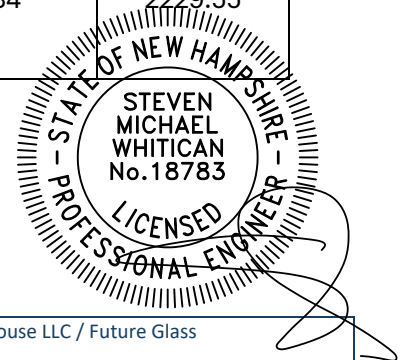

Project Description: Glass Warehouse LLC / Future Glass RAN-CHRES Base Shoe Engineering Analysis	Date: January 30, 2025	Customer: Glass Warehouse LLC / Future Glass	
	Engineer: SH	Project #: EEV-24-0207	
		PER: 9164	Page #: Page 11 of 28



**Table 15: Installation Design Pressure Table**

Anchors Allowable Wind Load Capacity (PSF)							
Substrate	Anchor Type	Guard Height (in.)					
		36	39.75	42	48	60	72
Wood SG = 0.55 min.	1/2" ASTM F593 Bolt	97.81	80.23	71.86	55.02	35.21	24.45
	3/8" Lag Screw	21.81	17.89	16.02	12.27	7.85	5.45
	1/2" Lag Screw	27.09	22.22	19.90	15.24	9.75	6.77
Concrete 4000 PSI min.	3/8" Dewalt Screw-Bolt+	44.75	36.71	32.88	25.17	16.11	11.19
	1/2" Dewalt Screw-Bolt+	55.69	45.67	40.91	31.32	20.05	13.92
	3/8" ITW RedHead Dynabolt	14.17	11.62	10.41	7.97	5.10	3.54
	1/2" ITW RedHead Dynabolt	20.11	16.50	14.78	11.31	7.24	5.03
	3/8" Hilti HIT-Z Rod with HIT-HY 200 Adhesive	23.63	19.38	17.36	13.29	8.51	5.91
	1/2" Hilti HIT-Z Rod with HIT-HY 200 Adhesive	30.48	25.00	22.39	17.14	10.97	7.62
Steel 1/4" Thk. Min.	3/8" HWH Self-Tapping Screw	28.16	23.10	20.69	15.84	10.14	7.04
	1/2" HWH Self-Tapping Screw	37.53	30.79	27.58	21.11	13.51	9.38

\*Note: Common wood species with SG ≥ 0.42 include the following: Spruce Pine Fir, Southern Pine, Mixed Maple, Douglas Fir Larch.

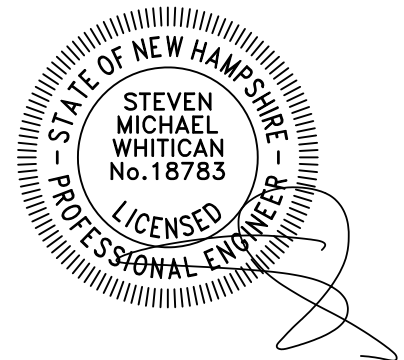

Project Description: Glass Warehouse LLC / Future Glass RAN-CHRES Base Shoe Engineering Analysis	Date: January 30, 2025	Customer: Glass Warehouse LLC / Future Glass	
	Engineer: SH	Project #: EEV-24-0207	
	PER: 9164	Page #: Page 12 of 28	

**Handrail Allowable Span Calculations**

Guard applications require a top rail or handrail. The rail shall have adequate strength to support the live load of 200 lb concentrated or 50 plf distributed load assuming the failure of one glass light at the location of the loading. No US building codes or adopted standards define the limit state of the guard hand rail for this condition. IBC 2407.1.2 states “shall be otherwise supported to remain in place should one baluster fail.” There is no additional explanation in the IBC as to how this is to be determined. ICC Acceptance Criteria 439 was adopted to provide a methodology for determining if a glass balustrade guard meets the requirements of IBC 2407. ICC AC 439 requires the rail to be capable of supporting a 334# load (SF = 1.67 for 200# load) with no more than 12” deflection, yielding or other damage is permitted since the loss of a glass light will necessitate guard repairs. For light failure only the horizontal load case applies for laminated glass.

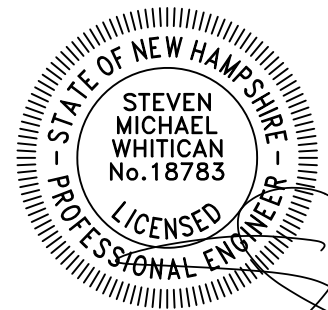
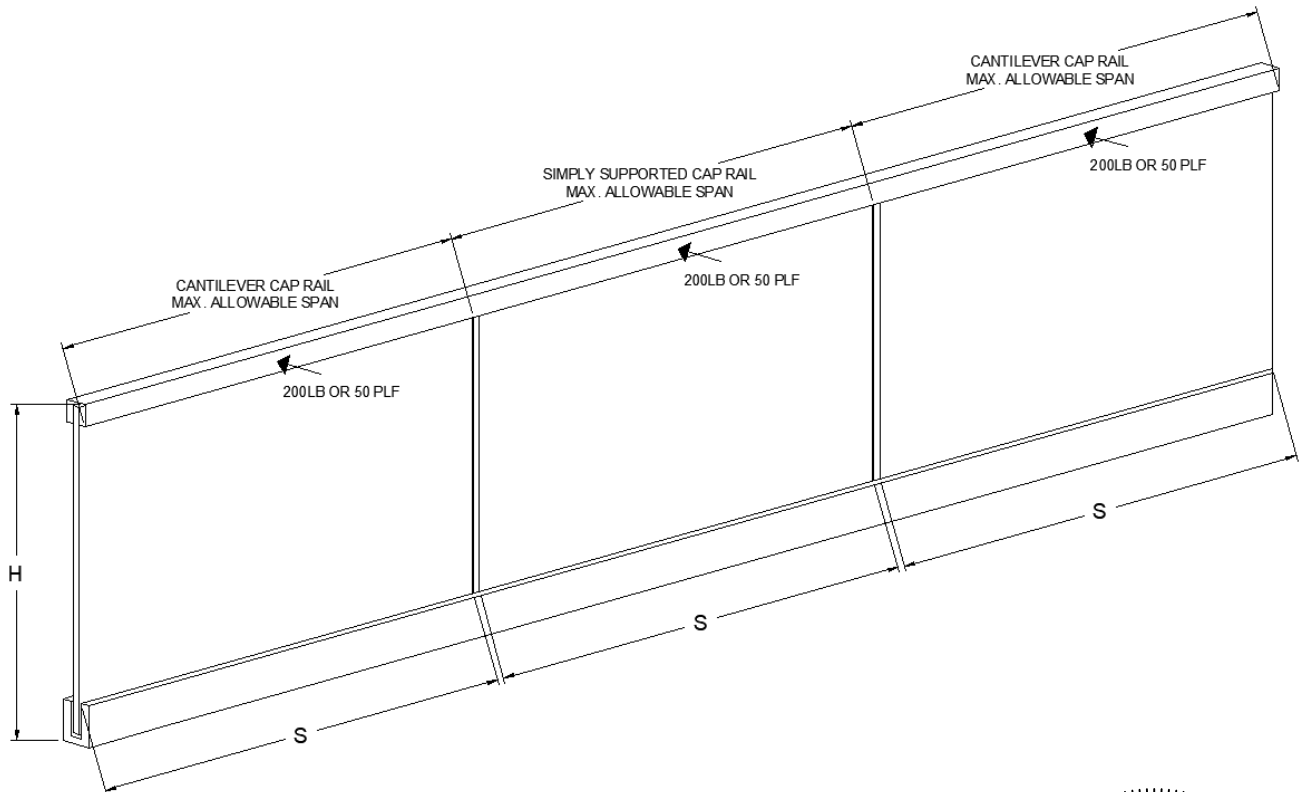

Project Description: Glass Warehouse LLC / Future Glass RAN-CHRES Base Shoe Engineering Analysis	Date: January 30, 2025	Customer: Glass Warehouse LLC / Future Glass	
	Engineer: SH	Project #: EEV-24-0207	
	PER: 9164	Page #: Page 13 of 28	

**COR-AHS Handrail Allowable Span**

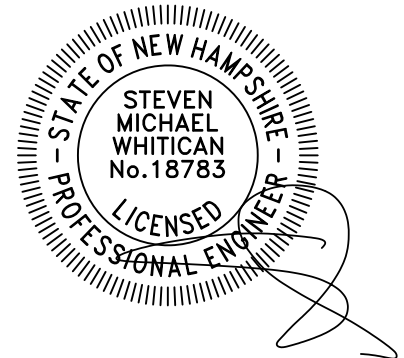
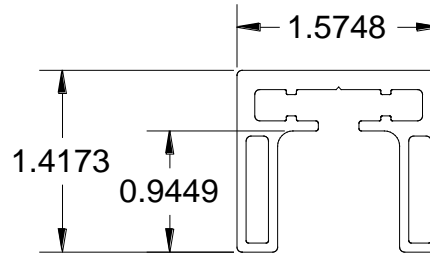

Cap Rail = AH4036  
 Area = 0.7269 in<sup>2</sup>  
 Perim. = 14.3614 in  
 Ixx = 0.1389 in<sup>4</sup>  
 Iyy = 0.2377 in<sup>4</sup>  
 rxx = 0.4371 in  
 ryy = 0.5719 in  
 Cxx = 0.7875 in  
 Cyy = 0.8968 in  
 Sxx = 0.1549 in<sup>3</sup>  
 Syy = 0.3018 in<sup>3</sup>  
 t = 0.071 in  
 w = 0.9449 in

Material = 2205 Stainless Steel  
 Fy = 65 ksi  
 Fu = 90 ksi

$$F_{cr} = \frac{\pi^2 k \eta E_o}{12(1-\mu^2)(w/t)^2}$$

η (Plasticity Reduction Factor) = 0.5 (Table A6a)  
 K (plate buckling coef.) = 3.51 (Section 2)  
 E<sub>o</sub> = 27000 ksi  
 μ (Poisson's Ratio) = 0.3 (Elastic Range)

$$\eta = \sqrt{\frac{E_t}{E_o}}$$

F<sub>cr</sub> = 241.67 ksi

Project Description: Glass Warehouse LLC / Future Glass RAN-CHRES Base Shoe Engineering Analysis	Date: January 30, 2025	Customer: Glass Warehouse LLC / Future Glass	
		Project #: EEV-24-0207	
	Engineer: SH	PER: 9164	Page #: Page 14 of 28

$$M_n = 1.25S_eF_y$$

$M_n$  Vertical Load = 12.5843 k-in  
 $M_n$  Horizontal Load = 24.5246 k-in

$$M_{nult} = S_eF_{cr}$$

$M_{ULT}$  Vertical Load = 13.9396 k-in  
 $M_{ULT}$  Horizontal Load = 27.1657 k-in

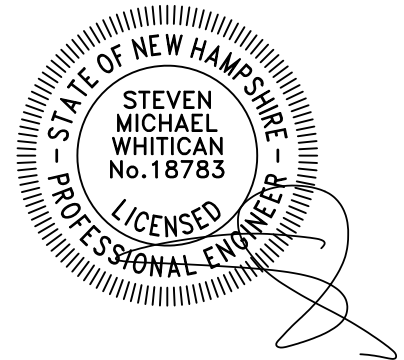

**Simply Supported Rail**

$$M_w = wL^2/10$$

$L_{uniform\ vert.}$  = 137.39 in  
 $L_{uniform\ horiz.}$  = 191.80 in

$$M_c = PL/5$$

$L_{concentrated\ vert.}$  = 188.39 in  
 $L_{concentrated\ horiz.}$  = 367.13 in

Allowable Rail Span = 137 in = 11.42 ft

**Cantilever Supported Rail**

$$M_{wc} = wL^2/2$$

$L_{uniform\ vert.}$  = 61.44 in  
 $L_{uniform\ horiz.}$  = 85.78 in

$$M_{cc} = PL$$

$L_{concentrated\ vert.}$  = 37.68 in  
 $L_{concentrated\ horiz.}$  = 73.43 in

Allowable Rail Span = 37 in = 3.08 ft

Project Description: Glass Warehouse LLC / Future Glass RAN-CHRES Base Shoe Engineering Analysis	Date: January 30, 2025	Customer: Glass Warehouse LLC / Future Glass	
		Project #: EEV-24-0207	
	Engineer: SH	PER: 9164	Page #: Page 15 of 28

**DRA-AHR42 Handrail Allowable Span**

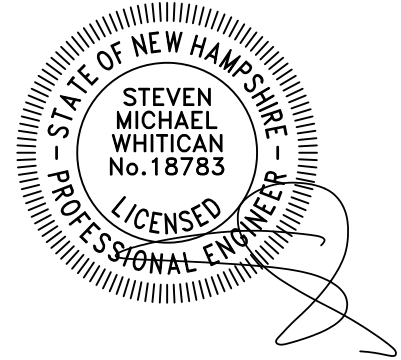
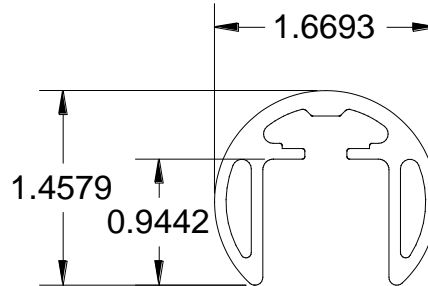

- Cap Rail = AHR42
- Area = 0.6745 in<sup>2</sup>
- Perim. = 11.8379 in
- Ixx = 0.1130 in<sup>4</sup>
- Iyy = 0.1996 in<sup>4</sup>
- rxx = 0.4092 in
- ryy = 0.5439 in
- Cxx = 0.8347 in
- Cyy = 0.8254 in
- Sxx = 0.1369 in<sup>3</sup>
- Syy = 0.2391 in<sup>3</sup>
- t = 0.0866 in
- w = 0.9442 in
- Material = 2205 Stainless Steel
- Fy = 65 ksi
- Fu = 90 ksi

$$F_{cr} = \frac{\pi^2 k \eta E_0}{12(1-\mu^2)(w/t)^2}$$

- η (Plasticity Reduction Factor) = 0.5 (Table A6a)
- K (plate buckling coef.) = 4 (Section 2)
- E<sub>0</sub> = 27000 ksi
- μ (Poisson's Ratio) = 0.3 (Elastic Range)

$$\eta = \sqrt{\frac{E_t}{E_o}}$$

F<sub>cr</sub> = 410.56 ksi

Project Description: Glass Warehouse LLC / Future Glass RAN-CHRES Base Shoe Engineering Analysis	Date: January 30, 2025	Customer: Glass Warehouse LLC / Future Glass	
	Engineer: SH	Project #: EEV-24-0207	
		PER: 9164	Page #: Page 16 of 28

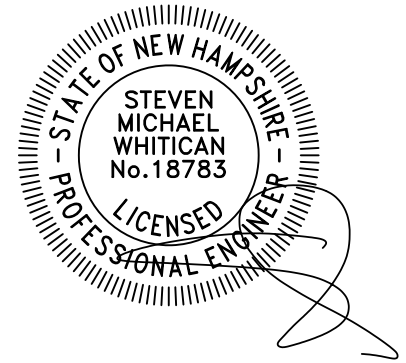

$$M_n = 1.25 S_e F_y$$

$$M_{n \text{ Vertical Load}} = 11.1234 \text{ k-in}$$

$$M_{n \text{ Horizontal Load}} = 19.4291 \text{ k-in}$$

$$M_{nult} = S_e F_{cr}$$

$$M_{ULT \text{ Vertical Load}} = 12.3213 \text{ k-in}$$

$$M_{ULT \text{ Horizontal Load}} = 21.5215 \text{ k-in}$$

**Simply Supported Rail**

$$M_w = wL^2/10$$

$$L_{\text{uniform Vert.}} = 129.17 \text{ in}$$

$$L_{\text{uniform Horiz.}} = 170.72 \text{ in}$$

$$M_c = PL/5$$

$$L_{\text{concentrated vert.}} = 166.52 \text{ in}$$

$$L_{\text{concentrated horiz.}} = 290.86 \text{ in}$$

Allowable Rail Span = 129 in = 10.75 ft

**Cantilever Supported Rail**

$$M_{wc} = wL^2/2$$

$$L_{\text{uniform Vert.}} = 57.77 \text{ in}$$

$$L_{\text{uniform Horiz.}} = 76.35 \text{ in}$$

$$M_{cc} = PL$$

$$L_{\text{concentrated vert.}} = 33.30 \text{ in}$$

$$L_{\text{concentrated horiz.}} = 58.17 \text{ in}$$

Allowable Rail Span = 33 in = 2.75 ft

Project Description: Glass Warehouse LLC / Future Glass RAN-CHRES Base Shoe Engineering Analysis	Date: January 30, 2025	Customer: Glass Warehouse LLC / Future Glass	
		Project #: EEV-24-0207	
	Engineer: SH	PER: 9164	Page #: Page 17 of 28

AGE-SHR42 Handrail Allowable Span

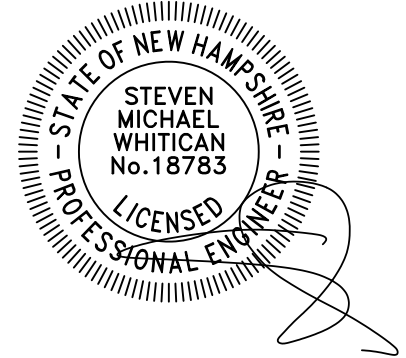
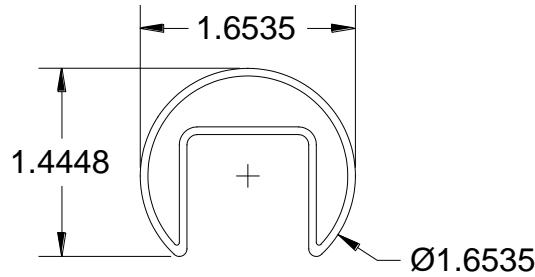

Cap Rail = HR42  
 Area = 0.3905 in<sup>2</sup>  
 Perim. = 13.2204 in  
 Ixx = 0.0668 in<sup>4</sup>  
 Iyy = 0.1178 in<sup>4</sup>  
 rxx = 0.4135 in  
 ryy = 0.5492 in  
 Cxx = 0.8268 in  
 Cyy = 0.7533 in  
 Sxx = 0.0887 in<sup>3</sup>  
 Syy = 0.1425 in<sup>3</sup>  
 t = 0.059055 in  
 w = 0.7224 in  
 Material = 2205 Stainless Steel  
 Fy = 65 ksi  
 Fu = 90 ksi

$$F_{cr} = \frac{\pi^2 k \eta E_o}{12(1-\mu^2)(w/t)^2}$$

η (Plasticity Reduction Factor) = 0.62 (Table A6a)  
 K (plate buckling coef.) = 4 (Section 2)  
 E<sub>o</sub> = 29000 ksi  
 μ (Poisson's Ratio) = 0.3 (Elastic Range)

$$\eta = \sqrt{\frac{E_t}{E_o}}$$

F<sub>cr</sub> = 434.40 ksi

Project Description: Glass Warehouse LLC / Future Glass RAN-CHRES Base Shoe Engineering Analysis	Date: January 30, 2025	Customer: Glass Warehouse LLC / Future Glass	
	Engineer: SH	Project #: EEV-24-0207	
		PER: 9164	Page #: Page 18 of 28

$$M_n = 1.25 S_e F_y$$

$M_n$  Vertical Load = 7.2050 k-in  
 $M_n$  Horizontal Load = 11.5763 k-in

$$M_{mult} = S_e F_{cr}$$

$M_{ULT}$  Vertical Load = 38.5208 k-in  
 $M_{ULT}$  Horizontal Load = 61.8915 k-in

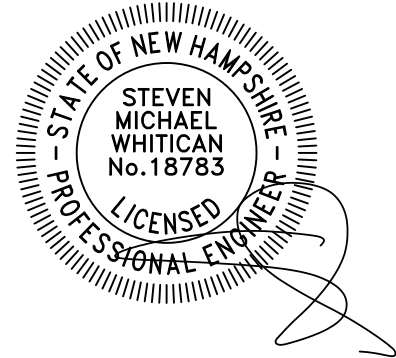

**Simply Supported Rail**

$$M_w = wL^2/10$$

$L_{uniform\ vert.}$  = 131.50 in  
 $L_{uniform\ horiz.}$  = 166.68 in

$$M_c = PL/5$$

$L_{concentrated\ vert.}$  = 180.12 in  
 $L_{concentrated\ horiz.}$  = 289.41 in

Allowable Rail Span = 131 in = 10.92 ft

**Cantilever Supported Rail**

$$M_{wc} = wL^2/2$$

$L_{uniform\ vert.}$  = 58.81 in  
 $L_{uniform\ horiz.}$  = 74.54 in

$$M_{cc} = PL$$

$L_{concentrated\ vert.}$  = 36.02 in  
 $L_{concentrated\ horiz.}$  = 57.88 in

Allowable Rail Span = 36 in = 3.00 ft

Project Description: Glass Warehouse LLC / Future Glass RAN-CHRES Base Shoe Engineering Analysis	Date: January 30, 2025	Customer: Glass Warehouse LLC / Future Glass	
	Engineer: SH	Project #: EEV-24-0207	
		PER: 9164	Page #: Page 19 of 28

**MAT-SHS Handrail Allowable Span**

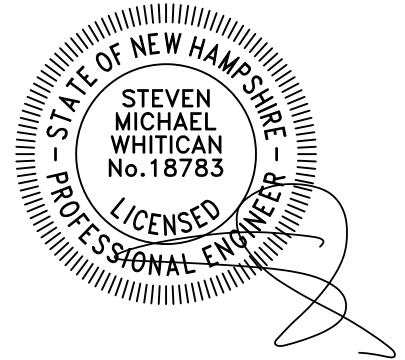
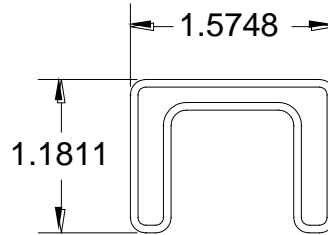

Cap Rail = MH4030S-XS

- Area = 0.4022 in<sup>2</sup>
- Perim. = 13.621 in
- I<sub>xx</sub> = 0.0588 in<sup>4</sup>
- I<sub>yy</sub> = 0.1302 in<sup>4</sup>
- r<sub>xx</sub> = 0.3824 in
- r<sub>yy</sub> = 0.569 in
- C<sub>xx</sub> = 0.7874 in
- C<sub>yy</sub> = 0.7041 in
- S<sub>xx</sub> = 0.0835 in<sup>3</sup>
- S<sub>yy</sub> = 0.1654 in<sup>3</sup>
- t = 0.0591 in
- w = 0.59055 in

Material = 2205 Stainless Steel

- F<sub>y</sub> = 65 ksi
- F<sub>u</sub> = 90 ksi

$$F_{cr} = \frac{\pi^2 k \eta E_0}{12(1-\mu^2)(w/t)^2}$$

- η (Plasticity Reduction Factor) = 0.62 (Table A6a)
- K (plate buckling coef.) = 4 (Section 2)
- E<sub>0</sub> = 29000 ksi
- μ (Poisson's Ratio) = 0.3 (Elastic Range)

$$\eta = \sqrt{\frac{E_t}{E_o}}$$

F<sub>cr</sub> = 651.01 ksi

Project Description: Glass Warehouse LLC / Future Glass RAN-CHRES Base Shoe Engineering Analysis	Date: January 30, 2025	Customer: Glass Warehouse LLC / Future Glass	
		Project #: EEV-24-0207	
	Engineer: SH	PER: 9164	Page #: Page 20 of 28

$$M_n = 1.25S_e F_y$$

$$M_n \text{ Vertical Load} = 6.7853 \text{ k-in}$$

$$M_n \text{ Horizontal Load} = 13.4350 \text{ k-in}$$

$$M_{nult} = S_e F_{cr}$$

$$M_{ULT} \text{ Vertical Load} = 54.3665 \text{ k-in}$$

$$M_{ULT} \text{ Horizontal Load} = 107.6475 \text{ k-in}$$

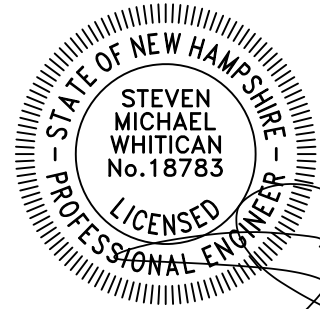

**Simply Supported Rail**

$$M_w = wL^2/10$$

$$L_{\text{uniform Vert.}} = 127.61 \text{ in}$$

$$L_{\text{uniform Horiz.}} = 179.57 \text{ in}$$

$$M_c = PL/5$$

$$L_{\text{concentrated vert.}} = 169.63 \text{ in}$$

$$L_{\text{concentrated horiz.}} = 335.88 \text{ in}$$

Allowable Rail Span =	127	in =	10.58	ft
-----------------------	-----	------	-------	----

**Cantilever Supported Rail**

$$M_{wc} = wL^2/2$$

$$L_{\text{uniform Vert.}} = 57.07 \text{ in}$$

$$L_{\text{uniform Horiz.}} = 80.30 \text{ in}$$

$$M_{cc} = PL$$

$$L_{\text{concentrated vert.}} = 33.93 \text{ in}$$

$$L_{\text{concentrated horiz.}} = 67.18 \text{ in}$$

Allowable Rail Span =	33	in =	2.75	ft
-----------------------	----	------	------	----

Project Description: Glass Warehouse LLC / Future Glass RAN-CHRES Base Shoe Engineering Analysis	Date: January 30, 2025	Customer: Glass Warehouse LLC / Future Glass	
		Project #: EEV-24-0207	
	Engineer: SH	PER: 9164	Page #: Page 21 of 28

HG25S XS Handrail Allowable Span

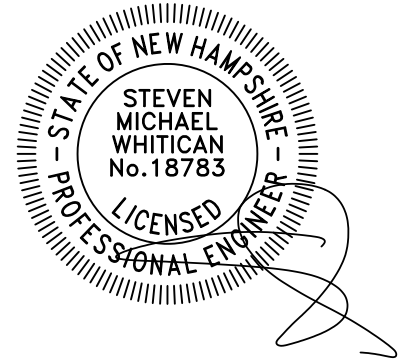
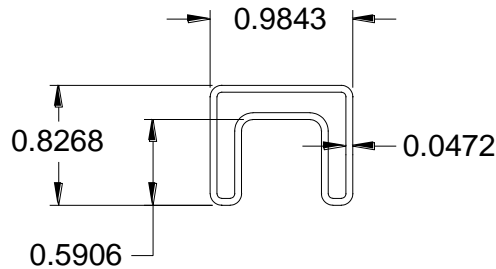

Cap Rail = HG25S

- Area = 0.2071 in<sup>2</sup>
- Perim. = 8.7687 in
- Ixx = 0.0143 in<sup>4</sup>
- Iyy = 0.0261 in<sup>4</sup>
- rxx = 0.2629 in
- ryy = 0.3548 in
- Cxx = 0.4921 in
- Cyy = 0.4685 in
- Sxx = 0.0305 in<sup>3</sup>
- Syy = 0.0530 in<sup>3</sup>
- t = 0.0472 in
- w = 0.5906 in

Material = 2205 Stainless Steel

- Fy = 65 ksi
- Fu = 90 ksi

$$F_{cr} = \frac{\pi^2 k \eta E_o}{12(1-\mu^2)(w/t)^2}$$

- η (Plasticity Reduction Factor) = 0.5 (Table A6a)
- K (plate buckling coef.) = 4 (Section 2)
- E<sub>o</sub> = 27000 ksi
- μ (Poisson's Ratio) = 0.3 (Elastic Range)

$$\eta = \sqrt{\frac{E_t}{E_o}}$$

F<sub>cr</sub> = 311.72 ksi

Project Description: Glass Warehouse LLC / Future Glass RAN-CHRES Base Shoe Engineering Analysis	Date: January 30, 2025	Customer: Glass Warehouse LLC / Future Glass	
	Engineer: SH	Project #: EEV-24-0207	
	PER: 9164	Page #: Page 22 of 28	

$$M_n = 1.25S_e F_y$$

$$M_n \text{ Vertical Load} = 2.4800 \text{ k-in}$$

$$M_n \text{ Horizontal Load} = 4.3093 \text{ k-in}$$

$$M_{mult} = S_e F_{cr}$$

$$M_{ULT} \text{ Vertical Load} = 2.7471 \text{ k-in}$$

$$M_{ULT} \text{ Horizontal Load} = 4.7734 \text{ k-in}$$

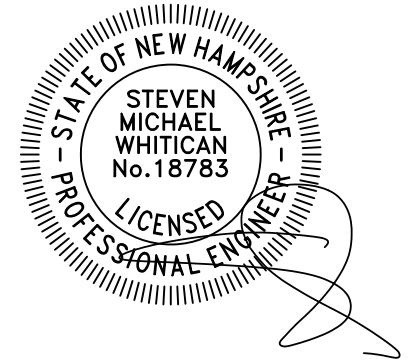

**Simply Supported Rail**

$$M_w = wL^2/10$$

$$L_{\text{uniform Vert.}} = 60.99 \text{ in}$$

$$L_{\text{uniform Horiz.}} = 80.40 \text{ in}$$

$$M_c = PL/5$$

$$L_{\text{concentrated vert.}} = 37.13 \text{ in}$$

$$L_{\text{concentrated horiz.}} = 64.51 \text{ in}$$

Allowable Rail Span =	37	in =	3.08	ft
-----------------------	----	------	------	----

**Cantilever Supported Rail**

$$M_{wc} = wL^2/2$$

$$L_{\text{uniform Vert.}} = 27.28 \text{ in}$$

$$L_{\text{uniform Horiz.}} = 35.96 \text{ in}$$

$$M_{cc} = PL$$

$$L_{\text{concentrated vert.}} = 7.43 \text{ in}$$

$$L_{\text{concentrated horiz.}} = 12.90 \text{ in}$$

Allowable Rail Span =	7	in =	0.58	ft
-----------------------	---	------	------	----

Project Description: Glass Warehouse LLC / Future Glass RAN-CHRES Base Shoe Engineering Analysis	Date: January 30, 2025	Customer: Glass Warehouse LLC / Future Glass	
	Engineer: SH	Project #: EEV-24-0207	
	PER: 9164	Page #: Page 23 of 28	



YOU ENVISION IT – WE ENGINEER IT

1900 NE Miami Ct., Ste. 2-15  
Miami, FL 33132  
TEL: 954.399-8478 | FAX: 954.744.4738  
WEB: [www.buildingdrops.com](http://www.buildingdrops.com)

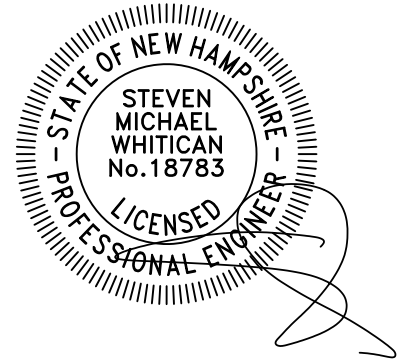

# APPENDIX

Project Description: Glass Warehouse LLC / Future Glass RAN-CHRES Base Shoe Engineering Analysis	Date: January 30, 2025	Customer: Glass Warehouse LLC / Future Glass	
		Project #: EEV-24-0207	
	Engineer: SH	PER: 9164	Page #: Page 24 of 28

Wind Loads on Fences or Guards

$p = q_h(GC_p) = q_zGC_f$  (ASCE 7-10 eq. 7-16)  
 $G = 0.85$  from (section 26.9.4.)  
 $C_f = 2.5 * 0.8 * 0.6 = 1.2$  (Figure 29.4-1) with reduction for solid and end returns, will vary.  
 $q_h = 0.00256K_zK_{zt}K_dV^2$  Where:  
 $K_z$  from (Table 29.3-1) at the height  $z$  of the railing centroid and exposure.  
 $K_d = 0.85$  from (Table 26-6).  
 $K_{zt}$  From (Figure 26.8-1) for the site topography, typically 1.0.  
 $V =$  Wind speed (mph) 3 second gust, (Figure 26.5-1A) or per local authority.  
 Simplifying - Assuming  $1.3 \leq C_f \leq 2.6$  (Typical limits for fence or guard with returns.)  
 Adjustment for full height solid:  $f = 1.8 - 1 = 0.8$   
 Adjustment to Allowable Stress Design:  $w_{asd} = 0.6w_{strength}$   
 For  $C_f = 1.3$ :  $F = q_h * 0.85 * 1.3 * 0.8 * 0.6 = 0.53 q_h$   
 For  $C_f = 2.6$ :  $F = q_h * 0.85 * 2.6 * 0.8 * 0.6 = 1.06 q_h$

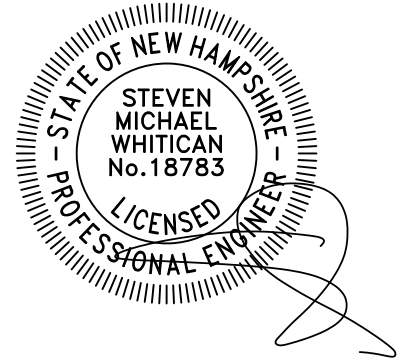

Exposure	B	C	D
$K_z =$	0.70	0.85	1.03

Centroid of wind load acts at 0.55h on the fence.

$w_{asd} = 0.53 * 0.00256 * K_z * V^2$  or  $w_{asd} = 1.06 * 0.00256 * K_z * V^2$

Wind Speed (mph)	Wind Loads (PSF)					
	$W_{ASD}$ for $C_f = 1.3$			$W_{ASD}$ for $C_f = 2.6$		
	Exp. B $K_z = 0.7$	Exp. C $K_z = 0.85$	Exp. D $K_z = 1.03$	Exp. B $K_z = 0.7$	Exp. C $K_z = 0.85$	Exp. D $K_z = 1.03$
100	9.50	11.53	13.98	19.00	23.07	27.95
110	11.49	13.95	16.91	22.98	27.91	33.82
120	13.68	16.61	20.12	27.35	33.21	40.25
130	16.05	19.49	23.62	32.10	38.98	47.24
140	18.62	22.60	27.39	37.23	45.21	54.78
150	21.37	25.95	31.44	42.74	51.90	62.89
160	24.31	29.52	35.78	48.63	59.05	71.55
170	27.45	33.33	40.39	54.90	66.66	80.78
180	30.77	37.37	45.28	61.54	74.73	90.56

Project Description: Glass Warehouse LLC / Future Glass RAN-CHRES Base Shoe Engineering Analysis	Date: January 30, 2025	Customer: Glass Warehouse LLC / Future Glass	
	Engineer: SH	Project #: EEV-24-0207	
		PER: 9164	Page #: Page 25 of 28



YOU ENVISION IT – WE ENGINEER IT

1900 NE Miami Ct., Ste. 2-15  
 Miami, FL 33132  
 TEL: 954.399-8478 | FAX: 954.744.4738  
 WEB: [www.buildingdrops.com](http://www.buildingdrops.com)

**7/16" Laminated Glass Capacity**

$$\begin{aligned}
 h_1 &= 0.180 \text{ in} \\
 h_2 &= 0.180 \text{ in} \\
 h_3 &= 0.060 \text{ in} \\
 h_s &= 0.5(h_1+h_2)+h_3 \\
 h_s &= 0.240 \text{ in} \\
 h_{s,1} &= h_{s,2} = (h_s h_1)/(h_1+h_2) \\
 h_{s,1} &= 0.120 \text{ in} \\
 h_{s,2} &= 0.120 \text{ in} \\
 I_s &= h_1 h_{s,2}^2 + h_2 h_{s,1}^2 \\
 I_s &= 0.0052
 \end{aligned}$$

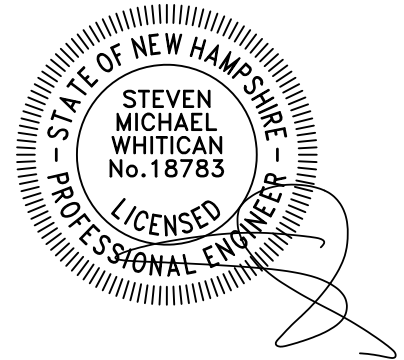

Shortest Dimension (a) (in)	$\Gamma$ PVB	$\Gamma$ PVB ES	$\Gamma$ SGP	$h_{ef,w}$ PVB	$h_{ef,w}$ PVB ES	$h_{ef,w}$ SGP	$h_{1,ef,\sigma}$ PVB	$h_{1,ef,\sigma}$ PVB ES	$h_{1,ef,\sigma}$ SGP
12	0.018	0.062	0.304	0.234	0.249	0.313	0.264	0.282	0.348
24	0.070	0.208	0.636	0.252	0.291	0.371	0.285	0.327	0.392
36	0.144	0.372	0.798	0.274	0.327	0.394	0.310	0.360	0.406
39.75	0.170	0.419	0.828	0.281	0.335	0.398	0.317	0.367	0.408
42	0.186	0.447	0.843	0.285	0.340	0.400	0.322	0.371	0.409
48	0.230	0.513	0.875	0.296	0.352	0.404	0.332	0.379	0.412
60	0.319	0.622	0.916	0.316	0.369	0.409	0.350	0.391	0.414
72	0.402	0.703	0.940	0.332	0.381	0.412	0.364	0.399	0.416

$$\begin{aligned}
 \Gamma &= 1/[1+9.6(EI_s h_3)/(Gh^2 a^2)] \\
 \text{effective thickness for deflection:} \\
 h_{ef,w} &= (h_1^3 + h_2^3 + 12\Gamma I_s)^{1/3} \\
 \text{effective thickness for glass stress:} \\
 h_{1,ef,\sigma} &= [h_{ef,w}^3 / (h + 2\Gamma h_{s,1})]^{1/2}
 \end{aligned}$$

Shortest Dimension (a) (in)	All. Wind Moment (lb-ft) PVB	All. Wind Moment (lb-ft) PVB ES	All. Wind Moment (lb-ft) SGP	All. LL Moment (lb-in/ft) PVB	All. LL Moment (lb-in/ft) PVB ES	All. LL Moment (lb-in/ft) SGP
12	123	141	214	833	965	1451
24	144	189	272	976	1285	1849
36	170	228	291	1153	1551	1980
39.75	178	238	295	1209	1614	2001
42	183	243	296	1242	1648	2012
48	195	254	299	1326	1725	2034
60	217	270	303	1473	1835	2060
72	234	281	306	1592	1907	2075

$$\begin{aligned}
 M_{GL} &= 6,000\text{psi} \cdot 2 \cdot h_{1,ef,\sigma}^2 = 12,000 h_{1,ef,\sigma}^2 \text{ \#ft} = 1,000 h_{1,ef,\sigma}^2 \text{ \#ft} \text{ For Live Loads} \\
 M_{LW} &= 9,600\text{psi} \cdot 2 \cdot h_{1,ef,\sigma}^2 \text{ For Wind Loads}
 \end{aligned}$$

**Glass Panel Loads**  
 From IBC 1607.7.1

Light Width (in)	Max. Panel Height Live Loads (in.)					
	50 plf PVB	50 plf PVB ES	50 plf SGP	200 lb PVB	200 lb PVB ES	200 lb SGP
12	16.67	19.10	29.02	33.33	38.21	58.05
24	19.51	25.70	36.97	78.05	102.80	147.88
36	23.07	31.02	39.60	138.41	186.15	237.58
39.75	24.18	32.29	40.03	160.21	213.90	265.19
42	24.84	32.96	40.24	173.86	230.74	281.68
48	26.51	34.50	40.68	212.09	276.03	325.40
60	29.46	36.71	41.21	294.60	367.06	412.08
72	31.84	38.13	41.51	382.09	457.57	498.08

For 50 plf distributed load:  
 $h = (M_d / u) = M_d / 50\text{plf}$

For 200# load, not top rail:  
 $h = M_d \cdot S / 200\#$  where S = light length in feet when installed with cap rail  
 For installation without a cap rail and load at corner of glass:  
 $h = M_d \cdot (2/3 \cdot S) / 200\#$  where S ≤ h

Project Description: Glass Warehouse LLC / Future Glass RAN-CHRES Base Shoe Engineering Analysis	Date: January 30, 2025	Customer: Glass Warehouse LLC / Future Glass	
	Engineer: SH	Project #: EEV-24-0207	
	PER: 9164	Page #: Page 26 of 28	



YOU ENVISION IT – WE ENGINEER IT

1900 NE Miami Ct., Ste. 2-15  
 Miami, FL 33132  
 TEL: 954.399-8478 | FAX: 954.744.4738  
 WEB: [www.buildingdrops.com](http://www.buildingdrops.com)

**9/16" Laminated Glass Capacity**

$$\begin{aligned}
 h_1 &= 0.219 \text{ in} \\
 h_2 &= 0.219 \text{ in} \\
 h_v &= 0.060 \text{ in} \\
 h_s &= 0.5(h_1+h_2)+h_v \\
 h_s &= 0.279 \text{ in} \\
 h_{s,1} &= h_{s,2} = (h_s h_1)/(h_1+h_2) \\
 h_{s,1} &= 0.140 \text{ in} \\
 h_{s,2} &= 0.140 \text{ in} \\
 I_s &= h_1 h_{s,2}^2 + h_2 h_{s,1}^2 \\
 I_s &= 0.0085
 \end{aligned}$$

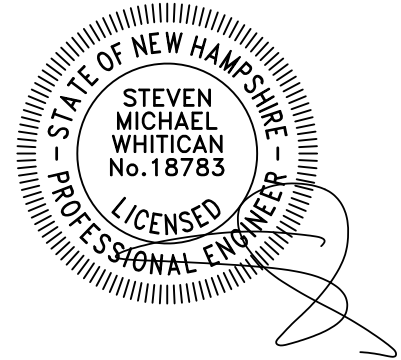

Shortest Dimension (a) (in)	$\Gamma$ PVB	$\Gamma$ PVB ES	$\Gamma$ SGP	$h_{ef,W}$ PVB	$h_{ef,W}$ PVB ES	$h_{ef,W}$ SGP	$h_{1,ef,\sigma}$ PVB	$h_{1,ef,\sigma}$ PVB ES	$h_{1,ef,\sigma}$ SGP
12	0.015	0.051	0.265	0.283	0.297	0.364	0.318	0.335	0.405
24	0.058	0.178	0.590	0.300	0.340	0.433	0.338	0.382	0.461
36	0.121	0.328	0.764	0.322	0.379	0.463	0.364	0.419	0.479
39.75	0.144	0.373	0.798	0.329	0.390	0.468	0.371	0.428	0.482
42	0.158	0.399	0.815	0.334	0.395	0.471	0.376	0.433	0.484
48	0.197	0.464	0.852	0.345	0.409	0.476	0.388	0.443	0.487
60	0.278	0.575	0.900	0.367	0.431	0.484	0.408	0.459	0.490
72	0.356	0.661	0.928	0.386	0.446	0.488	0.425	0.469	0.493

$\Gamma = 1/[1+9.6(EL_h)/(Gh^2a^2)]$   
 effective thickness for deflection:  
 $h_{ef,W} = (h_1^3 + h_2^3 + 12\Gamma I_s)^{1/3}$   
 effective thickness for glass stress:  
 $h_{1,ef,\sigma} = [h_{ef,W}^3/(h+2\Gamma h_{s,1})]^{1/2}$

Shortest Dimension (a) (in)	All. Wind Moment (lb-ft) PVB	All. Wind Moment (lb-ft) PVB ES	All. Wind Moment (lb-ft) SGP	All. LL Moment (lb-in/ft) PVB	All. LL Moment (lb-in/ft) PVB ES	All. LL Moment (lb-in/ft) SGP
12	179	199	290	1213	1351	1970
24	202	258	375	1374	1751	2545
36	234	310	405	1586	2107	2753
39.75	244	323	411	1655	2197	2788
42	250	331	413	1697	2245	2806
48	266	347	418	1804	2358	2842
60	294	372	425	2000	2525	2886
72	319	388	429	2165	2636	2911

$M_{dL} = 6,000\text{psi} \cdot 2 \cdot h_{1,ef,\sigma}^2 = 12,000 h_{1,ef,\sigma}^2$  #/ft =  $1,000 h_{1,ef,\sigma}^2$  #/ft For Live Loads  
 $M_{dW} = 9,600\text{psi} \cdot 2 \cdot h_{1,ef,W}^2$  For Wind Loads

**Glass Panel Loads**  
 From IBC 1607.7.1

Light Width (in)	Max. Panel Height Live Loads (in.)					
	50 plf PVB	50 plf PVB ES	50 plf SGP	200 lb PVB	200 lb PVB ES	200 lb SGP
12	24.25	27.01	39.40	48.50	54.02	78.80
24	27.48	35.03	50.90	109.94	140.11	203.59
36	31.73	42.15	55.07	190.37	252.90	330.39
39.75	33.11	43.93	55.77	219.34	291.06	369.47
42	33.93	44.90	56.11	237.52	314.33	392.80
48	36.07	47.16	56.83	288.58	377.28	454.67
60	39.99	50.49	57.72	399.91	504.90	577.20
72	43.30	52.72	58.22	519.58	632.59	698.66

For 50 plf distributed load:  
 $h = (M_d/L)/u = M_d/50\text{plf}$

For 200# load, not top rail:  
 $h = M_d \cdot S/200\#$  where S = light length in feet when installed with cap rail  
 For installation without a cap rail and load at corner of glass:  
 $h = M_d \cdot (2/3 \cdot S)/200\#$  where S ≤ h

Project Description: Glass Warehouse LLC / Future Glass RAN-CHRES Base Shoe Engineering Analysis	Date: January 30, 2025	Customer: Glass Warehouse LLC / Future Glass	
	Engineer: SH	Project #: EEV-24-0207	
	PER: 9164	Page #: Page 27 of 28	



YOU ENVISION IT – WE ENGINEER IT

1900 NE Miami Ct., Ste. 2-15  
 Miami, FL 33132  
 TEL: 954.399-8478 | FAX: 954.744.4738  
 WEB: [www.buildingdrops.com](http://www.buildingdrops.com)

**1 1/16" Laminated Glass Capacity**

$$\begin{aligned}
 h_1 &= 0.292 \text{ in} \\
 h_2 &= 0.292 \text{ in} \\
 h_v &= 0.060 \text{ in} \\
 h_s &= 0.5(h_1+h_2)+h_v \\
 h_s &= 0.352 \text{ in} \\
 h_{s,1} &= h_{s,2} = (h_s h_1)/(h_1+h_2) \\
 h_{s,1} &= 0.176 \text{ in} \\
 h_{s,2} &= 0.176 \text{ in} \\
 I_s &= h_1 h_{s,2}^2 + h_2 h_{s,1}^2 \\
 I_s &= 0.0181
 \end{aligned}$$

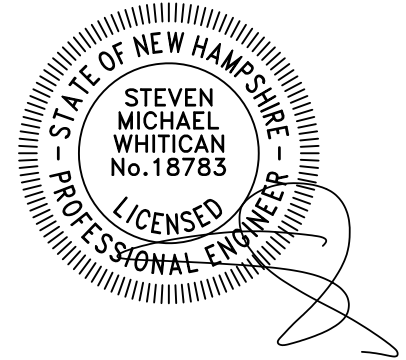

Shortest Dimension (a) (in)	$\Gamma$ PVB	$\Gamma$ PVB ES	$\Gamma$ SGP	$h_{def,W}$ PVB	$h_{def,W}$ PVB ES	$h_{def,W}$ SGP	$h_{1,def,\sigma}$ PVB	$h_{1,def,\sigma}$ PVB ES	$h_{1,def,\sigma}$ SGP
12	0.011	0.039	0.212	0.374	0.388	0.458	0.420	0.437	0.511
24	0.044	0.140	0.519	0.390	0.431	0.546	0.439	0.485	0.585
36	0.094	0.268	0.708	0.413	0.476	0.588	0.465	0.529	0.613
39.75	0.112	0.308	0.748	0.420	0.489	0.596	0.473	0.540	0.618
42	0.124	0.332	0.768	0.425	0.496	0.600	0.478	0.546	0.620
48	0.156	0.394	0.812	0.437	0.513	0.609	0.491	0.560	0.625
60	0.224	0.504	0.871	0.462	0.542	0.620	0.515	0.582	0.632
72	0.293	0.594	0.907	0.484	0.563	0.627	0.536	0.597	0.635

$\Gamma = 1/[1+9.6(EI_s h_v)/(Gh^3 a^2)]$   
 effective thickness for deflection:  
 $h_{def,W} = (h_1^3 + h_2^3 + 12\Gamma I_s)^{1/3}$   
 effective thickness for glass stress:  
 $h_{1,def,\sigma} = [h_{def,W}^3 / (h_1 + 2\Gamma h_{s,1})]^{1/2}$

Shortest Dimension (a) (in)	All. Wind Moment (lb-ft) PVB	All. Wind Moment (lb-ft) PVB ES	All. Wind Moment (lb-ft) SGP	All. LL Moment (lb-in/ft) PVB	All. LL Moment (lb-in/ft) PVB ES	All. LL Moment (lb-in/ft) SGP
12	312	337	462	2119	2287	3138
24	341	415	605	2316	2818	4107
36	381	494	664	2591	3352	4512
39.75	395	515	675	2685	3497	4584
42	404	527	680	2741	3577	4620
48	426	555	691	2892	3770	4696
60	469	599	705	3183	4069	4788
72	507	630	713	3445	4280	4842

$M_{dL} = 6,000\text{psi} \cdot 2 \cdot h_{1,def,\sigma}^2 = 12,000 h_{1,def,\sigma}^2$  #/ft =  $1,000 h_{1,def,\sigma}^2$  #/ft For Live Loads  
 $M_{dW} = 9,600\text{psi} \cdot 2 \cdot h_{1,def,\sigma}^2$  For Wind Loads

**Glass Panel Loads**  
 From IBC 1607.7.1

Light Width (in)	Max. Panel Height Live Loads (in.)					
	50 plf PVB	50 plf PVB ES	50 plf SGP	200 lb PVB	200 lb PVB ES	200 lb SGP
12	42.38	45.74	62.76	84.76	91.47	125.53
24	46.33	56.36	82.14	185.31	225.44	328.57
36	51.82	67.04	90.25	310.94	402.26	541.49
39.75	53.69	69.93	91.68	355.70	463.30	607.40
42	54.82	71.54	92.40	383.77	500.79	646.77
48	57.85	75.39	93.89	462.79	603.16	751.15
60	63.67	81.38	95.77	636.69	813.82	957.70
72	68.89	85.60	96.85	826.72	1027.16	1162.15

For 50 plf distributed load:  
 $h = (M_{dL}/t) = M_{dL}/50\text{plf}$

For 200# load, not top rail:  
 $h = M_{dL} \cdot S / 200\#$  where S = light length in feet when installed with cap rail  
 For installation without a cap rail and load at corner of glass:  
 $h = M_{dL} \cdot (2/3 \cdot S) / 200\#$  where S ≤ h

Project Description: Glass Warehouse LLC / Future Glass RAN-CHRES Base Shoe Engineering Analysis	Date: January 30, 2025	Customer: Glass Warehouse LLC / Future Glass	
	Engineer: SH	Project #: EEV-24-0207	
	PER: 9164	Page #: Page 28 of 28	