

COMPACT UNDERCOUNTER REFRIGERATORS

 MODEL: MXCR27U-FBHC

MXCR27U-FBHC

The Maxx Cold Front-Breathing Undercounter Refrigerator is designed for performance. The compact undercounter refrigerator makes the most of available space and the stainless steel exterior provides durability and ensures years of reliable service.

FEATURES AND CONSTRUCTION

- Durable, easy to clean stainless steel exterior
- Painted aluminum interior
- Easy to grip recessed door handle
- Supplied with one (1) adjustable heavy-duty wire shelf
- Equipped with four (4) 3" swivel casters
- Solid state digital control system
- LED temperature display
- Automatic defrost system
- Equipped with integrated condensate evaporator therefore no drain line connection is needed
- Urethane insulated walls and doors
- Accommodates full-size sheet pans
- Compact front-breathing design accommodates tight spaces

ELECTRIC

115V / 60Hz / 1Ph
 (230V / 50-60Hz / 1Ph is available as an option)
 6' (2m) NEMA 5-15P cord set included

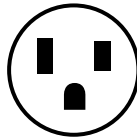

NEMA 5-15P

3RD PARTY APPROVALS



Intertek

Certified to ANSI NSF 7



Intertek

Certified to ANSI UL 471



Zero Ozone Depletion Potential



DOE 2018 Compliant

NET STORAGE CAPACITY

MXCR27U-FBHC 6.5 Cu Ft (184 L)

TEMPERATURE

Holding temperature 33°F to 41°F (1°C to 5°C)

- Efficient forced-air refrigeration system

MAXX COLD WARRANTY (USA / CANADA)

Contact Maxx Cold for warranty statement at
 TechnicalServices@TheLegacyCompanies.com or 877.368.2797

MXCR27U-FBHC

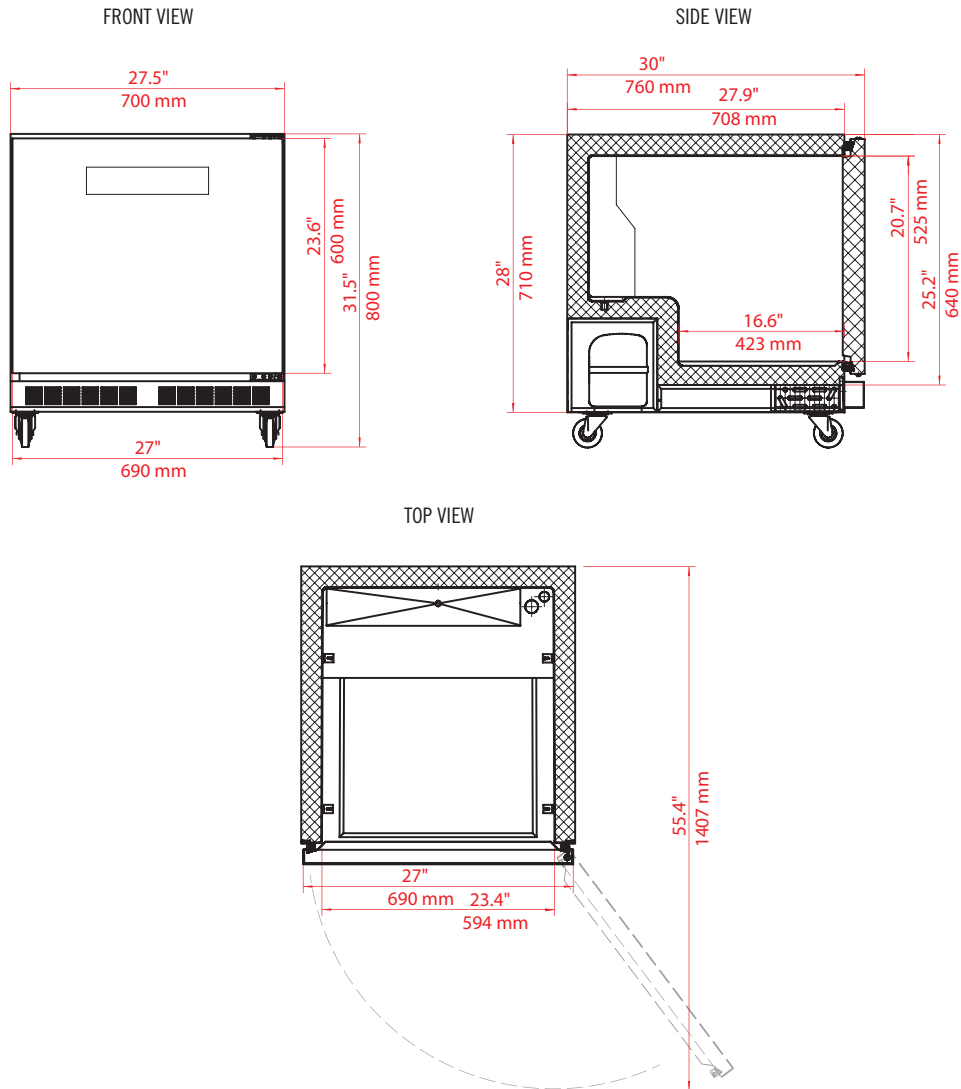

MODEL	EXTERNAL DIMENSIONS	INTERNAL DIMENSIONS	NET CAPACITY	HOLDING TEMPERATURE RANGE	AMP DRAW	SHIPPING WEIGHT	REFRIGERANT AND CHARGE SIZE	DOORS / SHELVES	ELECTRICAL
MXCR27U-FBHC	27.5" x 30" x 31.5" (700 x 760 x 800 mm)	23.4" x 16.6" x 20.7" (594 x 423 x 525 mm)	6.5 Cu Ft (184 L)	33°F to 41°F (1°C to 5°C)	1.5A	243 lbs (110 kg)	R-600a 2.47 oz (68 g)	1 / 1	115V / 60Hz / 1Ph

INSTALLATION

- Shorter caster options are available to lower the overall height of the unit to satisfy ADA or other low profile requirements