

INSTRUCTION MANUAL

TABLE OF CONTENTS

ASSEMBLY INSTRUCTIONS

Deep Seating Chair	3
Deep Seating Right Arm Chair	9
Deep Seating Left Arm Chair	15
Deep Seating Armless Chair	21
Combining Chairs	26
37" Conversation Table	27

INSTRUCTION MANUAL



Deep Seating Arm Chair

! CARE & MAINTENANCE

Please keep these instructions for your future reference.

- Be careful when assembling to avoid damaging the plating of the surface.
- Clean the chair with lukewarm water, mild detergent & soft cloth.
- Firmly secure all bolts before use. Do not use any part of this item as a step ladder.
- Make sure that all bolts, screws, and nuts are secure every 90 days.
- Do not use or store this item in the proximity of open flame or flammable/combustible chemicals.
- Be aware that some parts are heavy and have sharp edges.
- Do not overtighten screws (insert all screws before tightening screws).

TOOLS REQUIRED

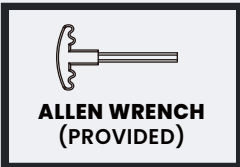

**330 LBS
CAPACITY**



**2 PERSON
ASSEMBLY**



**UP TO 30 MIN.
ASSEMBLY**

HARDWARE

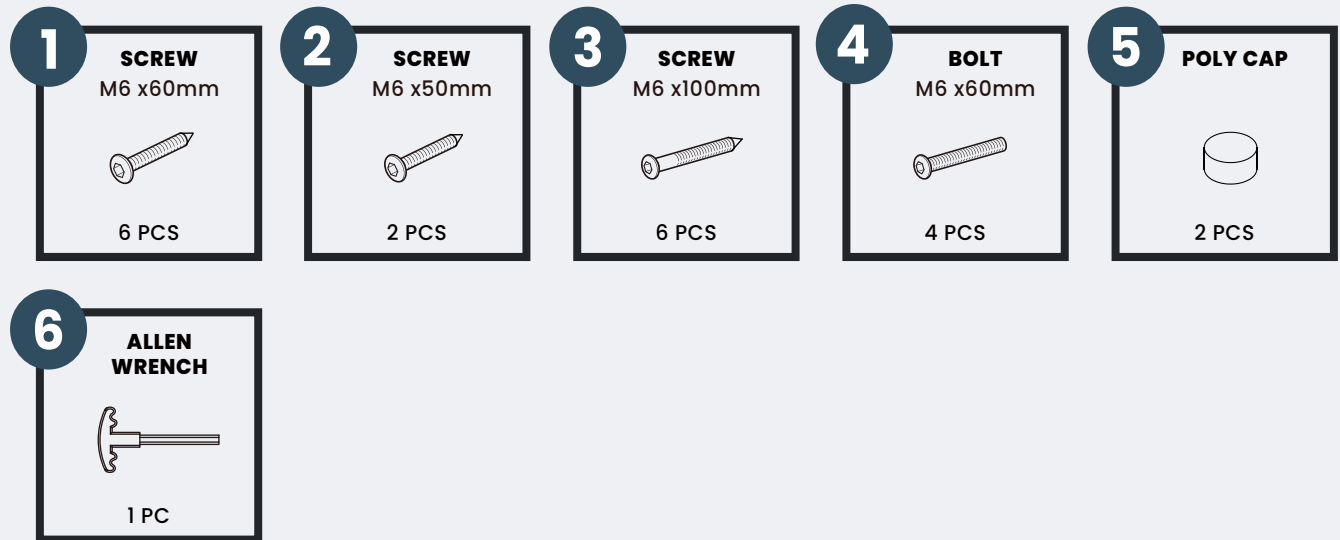

PARTS

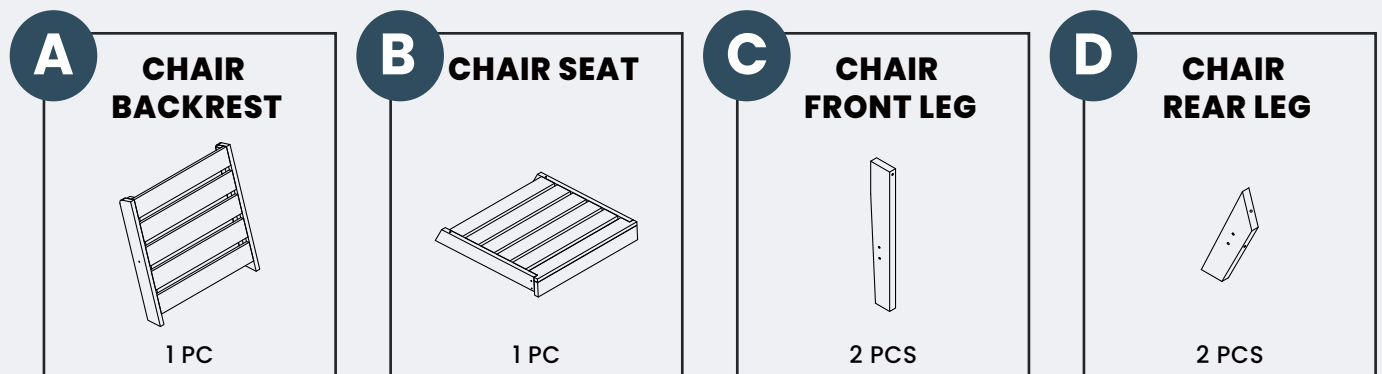

PARTS

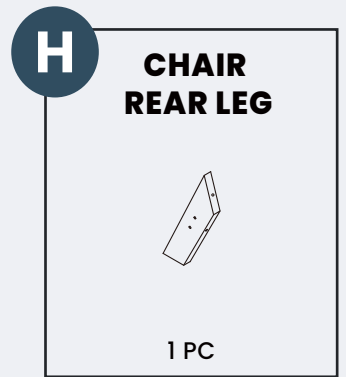
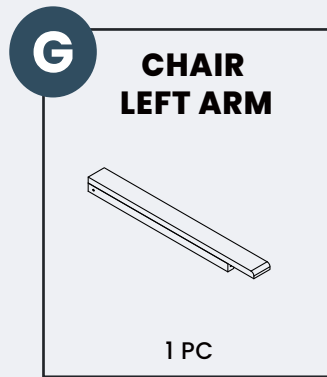
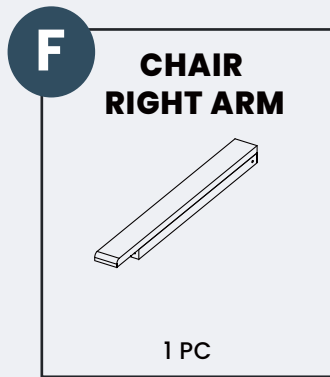
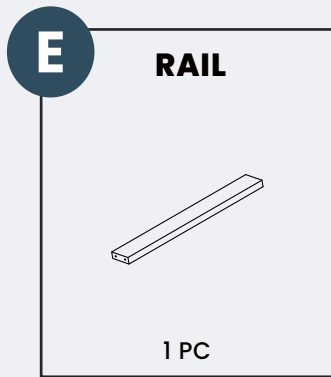

PRODUCT ASSEMBLY - OVERALL VIEW

Look at following overall view of this chair and learn the exact position of each parts to be assembled.

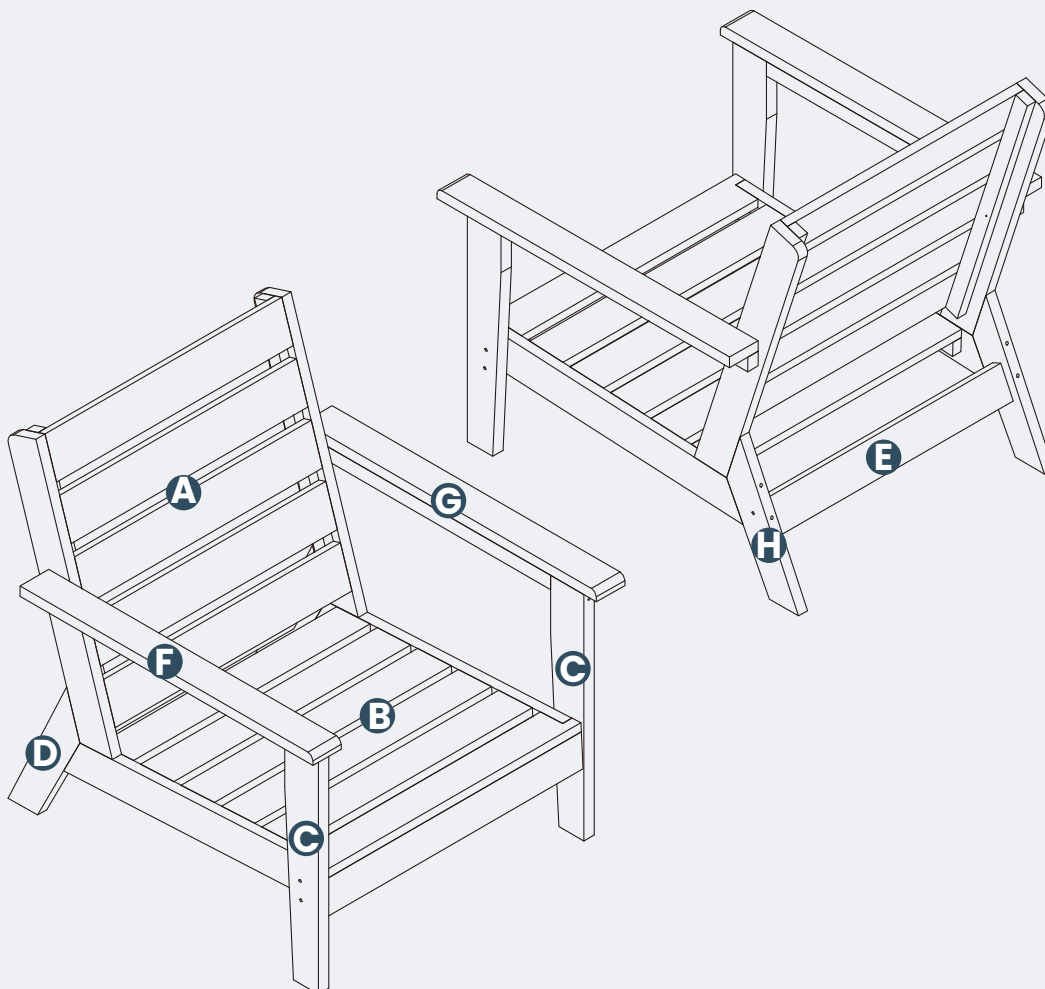

PRODUCT ASSEMBLY

1

Attach **part E Rail** to **part D** and **part H Rear Leg** with 4 pcs of hardware **#1 Screw**.

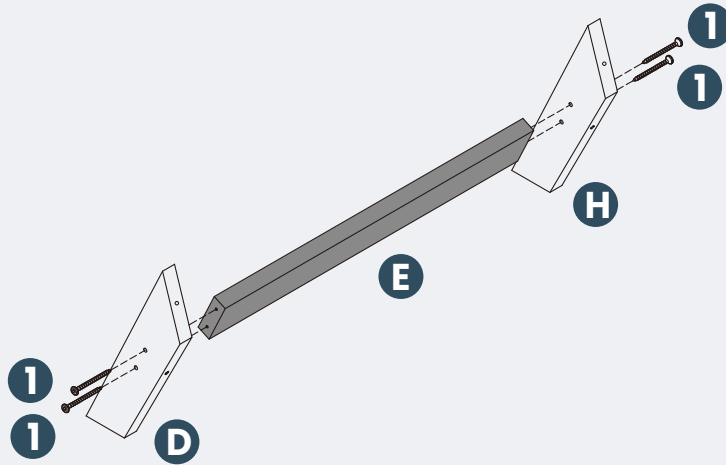

2

Attach **part D** and **part H Rear Leg** to part B Seat with 2 pcs of hardware **#3 Screw**.
Attach **part C Front Leg** to **part B Seat** with 4 pcs of hardware **#4 Bolt**.

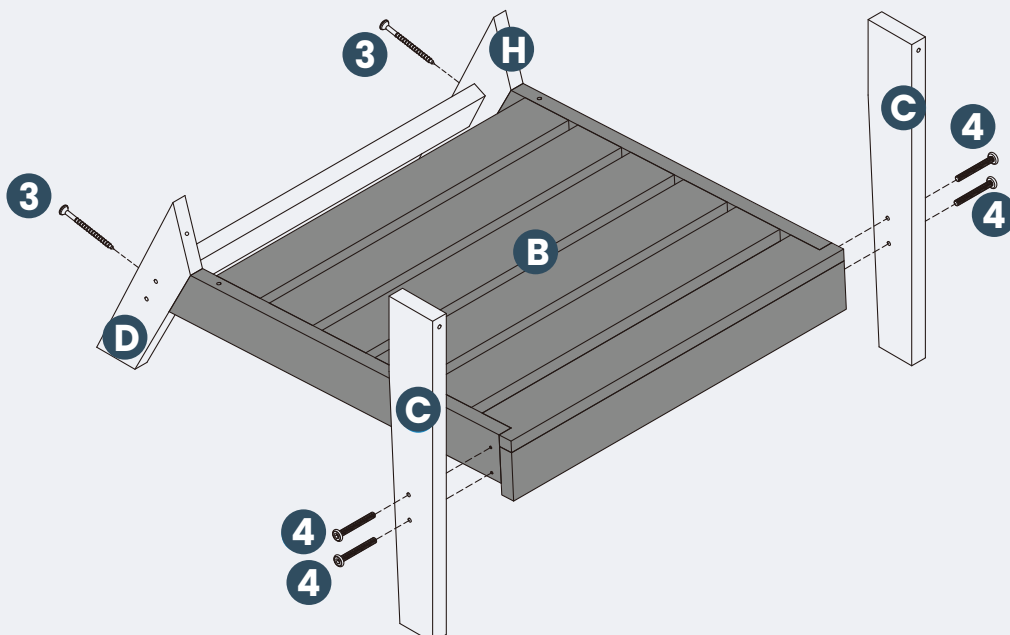

PRODUCT ASSEMBLY

3

Attach **part A Backrest** to **part B Seat** with 2 pcs of hardware **#3 Screw**.
Attach **part D** and **part H Rear Leg** to **part A Backrest** with 2 pcs of hardware **#1 Screw**.

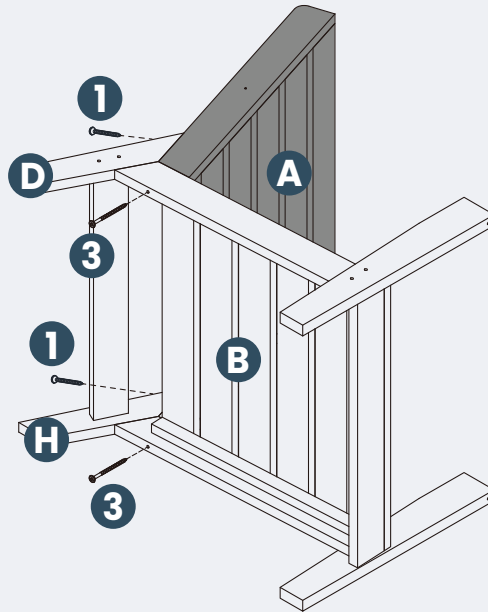

4

Attach **part F Right Arm** to **part A Backrest** with 1 pc of hardware **#2 Screw**.
Attach **part F Right Arm** to **part C Front Leg** with 1 pc of hardware **#3 Screw**.
Do the same to **part G Left Arm**.

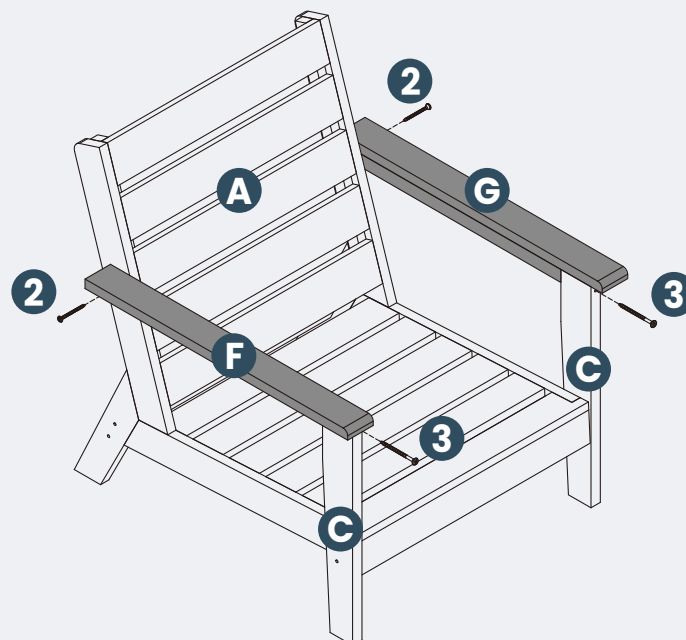

PRODUCT ASSEMBLY

5

The poly cap here is not easy to remove after being plugged in, and may cause the arm and front leg to be hard to disassemble. Please pay attention and decide whether you really need this poly cap or not during assembly.

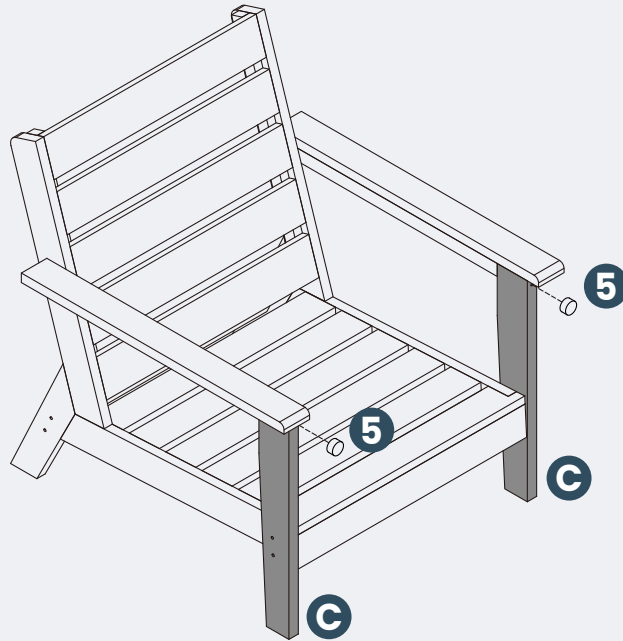

INSTRUCTION MANUAL

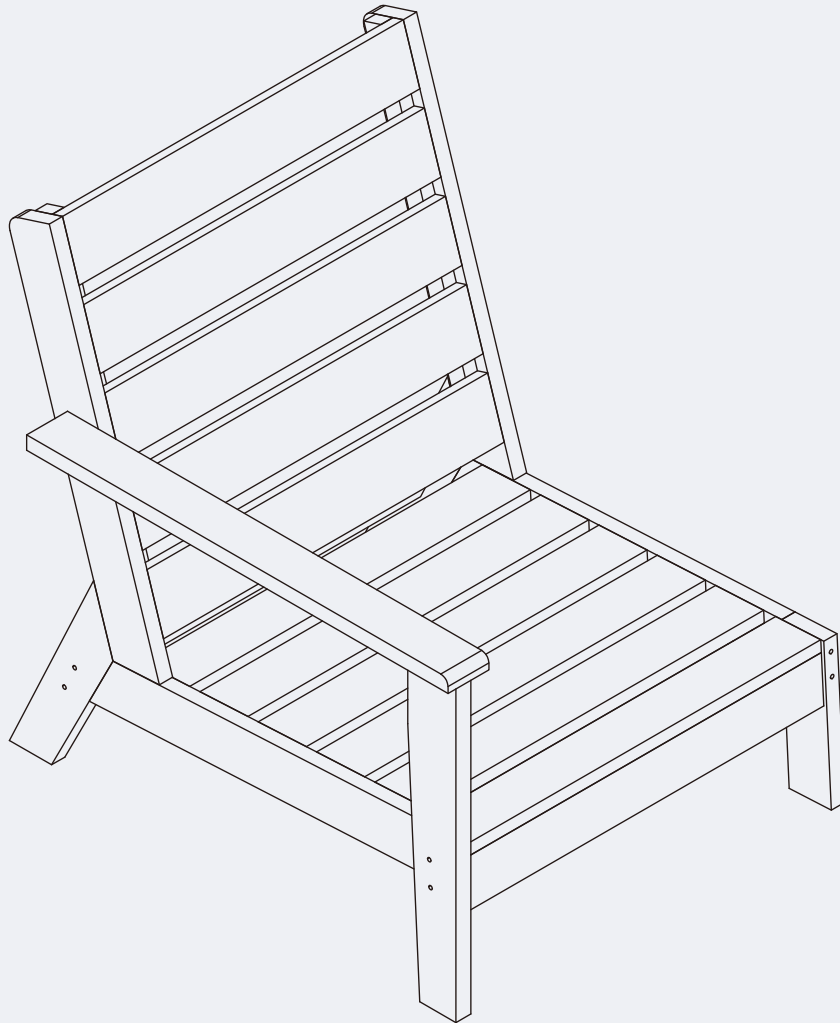

Deep Seating Right Arm Chair

! CARE & MAINTENANCE

Please keep these instructions for your future reference.

- Be careful when assembling to avoid damaging the plating of the surface.
- Clean the chair with lukewarm water, mild detergent & soft cloth.
- Firmly secure all bolts before use. Do not use any part of this item as a step ladder.
- Make sure that all bolts, screws, and nuts are secure every 90 days.
- Do not use or store this item in the proximity of open flame or flammable/combustible chemicals.
- Be aware that some parts are heavy and have sharp edges.
- Do not overtighten screws (insert all screws before tightening screws).

TOOLS REQUIRED

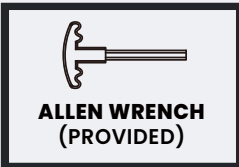

HARDWARE

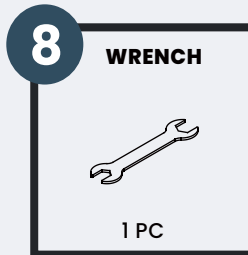
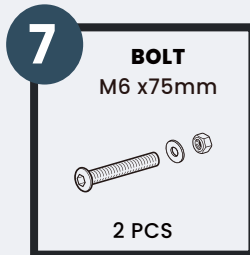
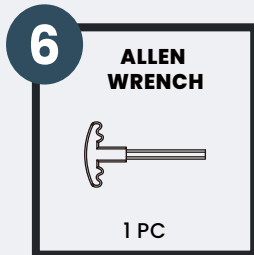
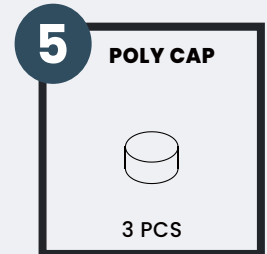
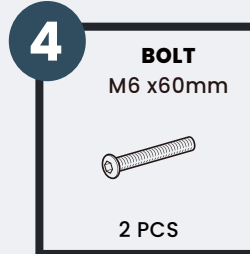
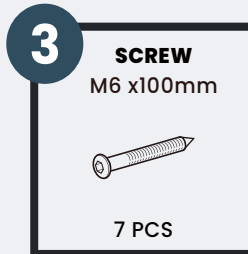
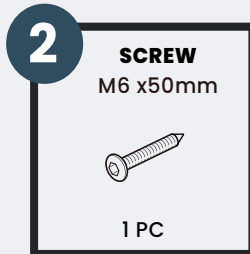
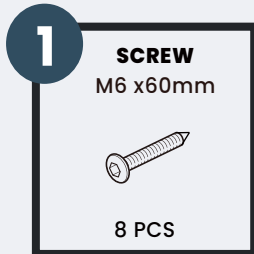

PARTS

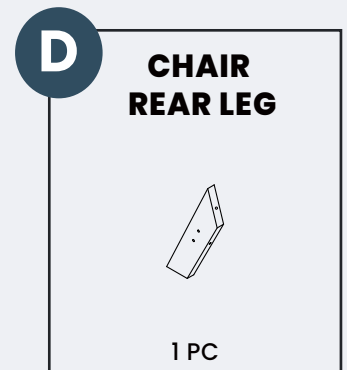
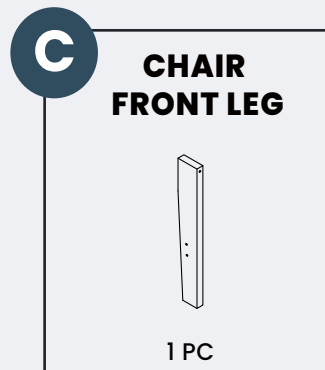
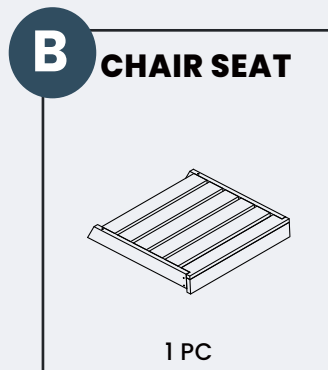
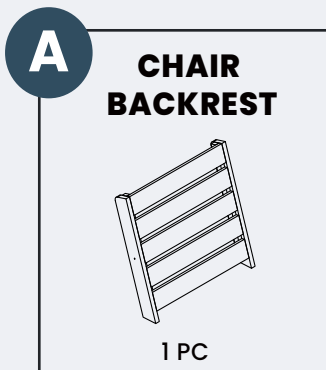

PARTS

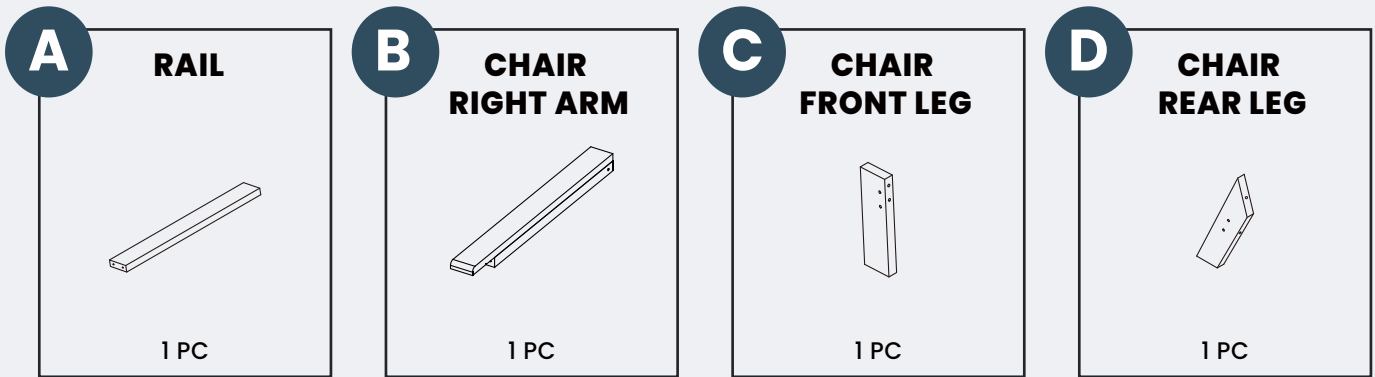

PRODUCT ASSEMBLY - OVERALL VIEW

Look at following overall view of this chair and learn the exact position of each parts to be assembled.

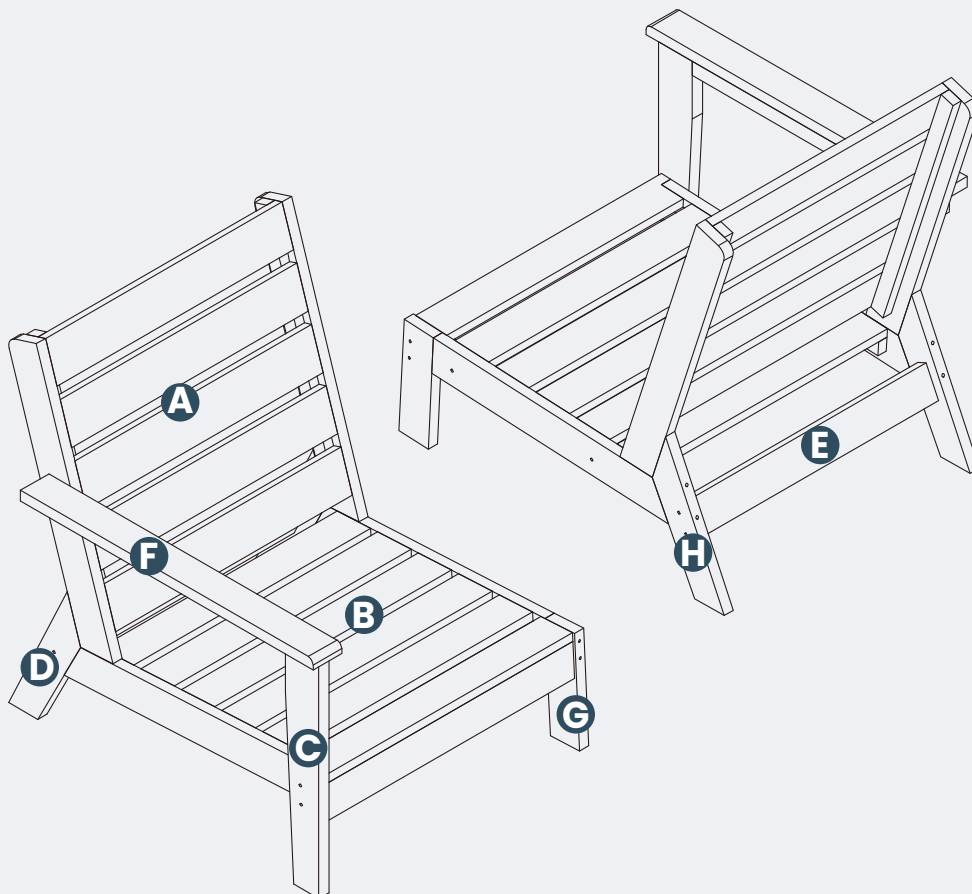

PRODUCT ASSEMBLY

1

Attach **part E Rail** to **part D** and **part H Rear Leg** with 4 pcs of hardware **#1 Screw**.

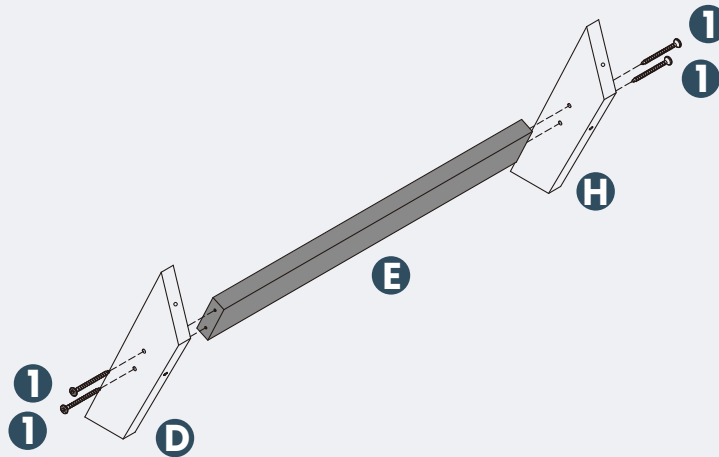

PRODUCT ASSEMBLY

2

Attach **part D** and **part H Rear Leg** to **part B Seat** with 2 pcs of hardware **#3 Screw**.
Attach **part C Front leg** to **part B Seat** with 2 pcs of hardware **#4 Bolt**.
Attach **part G Front Leg** to **part B Seat** with 2 pcs of hardware **#1 Screw**.

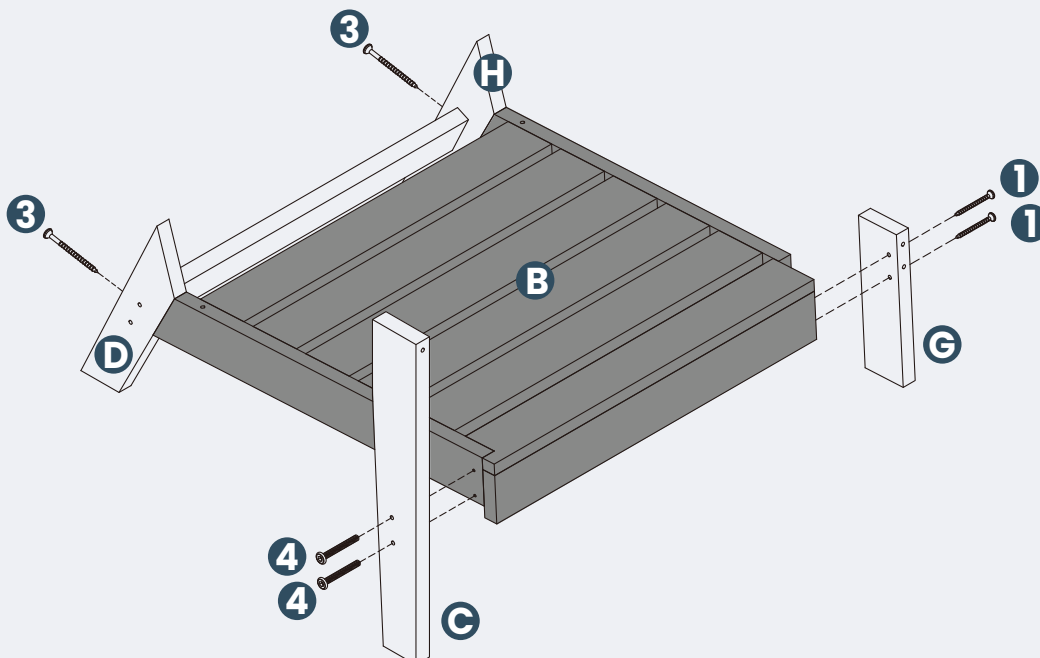

PRODUCT ASSEMBLY

3

Attach **part A Backrest** to **part B Seat** with 2 pcs of hardware **#3 Screw**.
Attach **part D** and **part H Rear Leg** to **part A Backrest** with 2 pcs of hardware **#1 Screw**.
Attach **part G Front Leg** to **part B Seat** with 2 pcs of hardware **#3 Screw**.

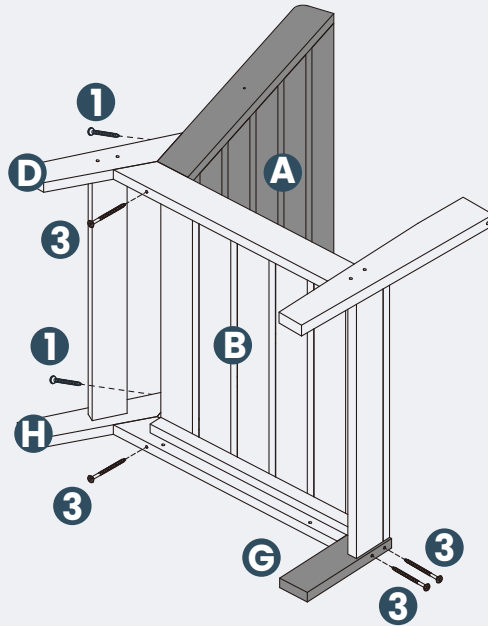

4

Attach **part F Right Arm** to **part A Backrest** with 1 pc of hardware **#2 Screw**.
Attach **part F Right Arm** to **part C Front Leg** with 1 pc of hardware **#3 Screw**.

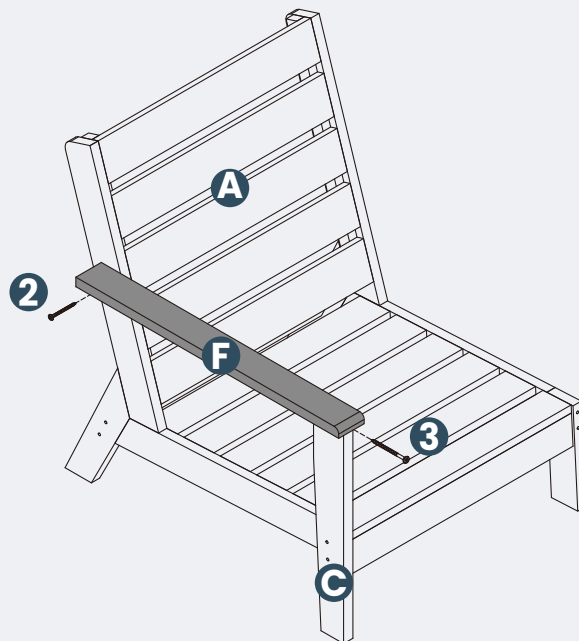

PRODUCT ASSEMBLY

5

The poly cap here is not easy to remove after being plugged in, and may cause the arm and front leg to be hard to disassemble. Please pay attention and decide whether you really need this poly cap or not during assembly.

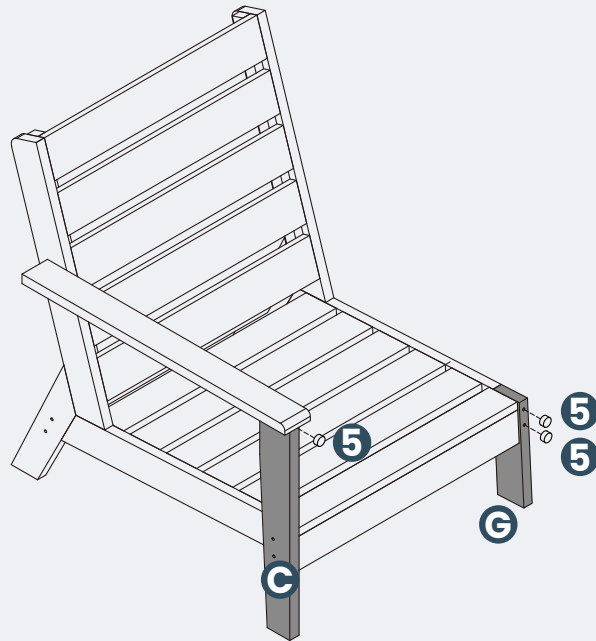

6

If you want to combine two or more chairs together, please do following steps. Use 2 pcs of hardware #7 Bolt to lock the chairs.

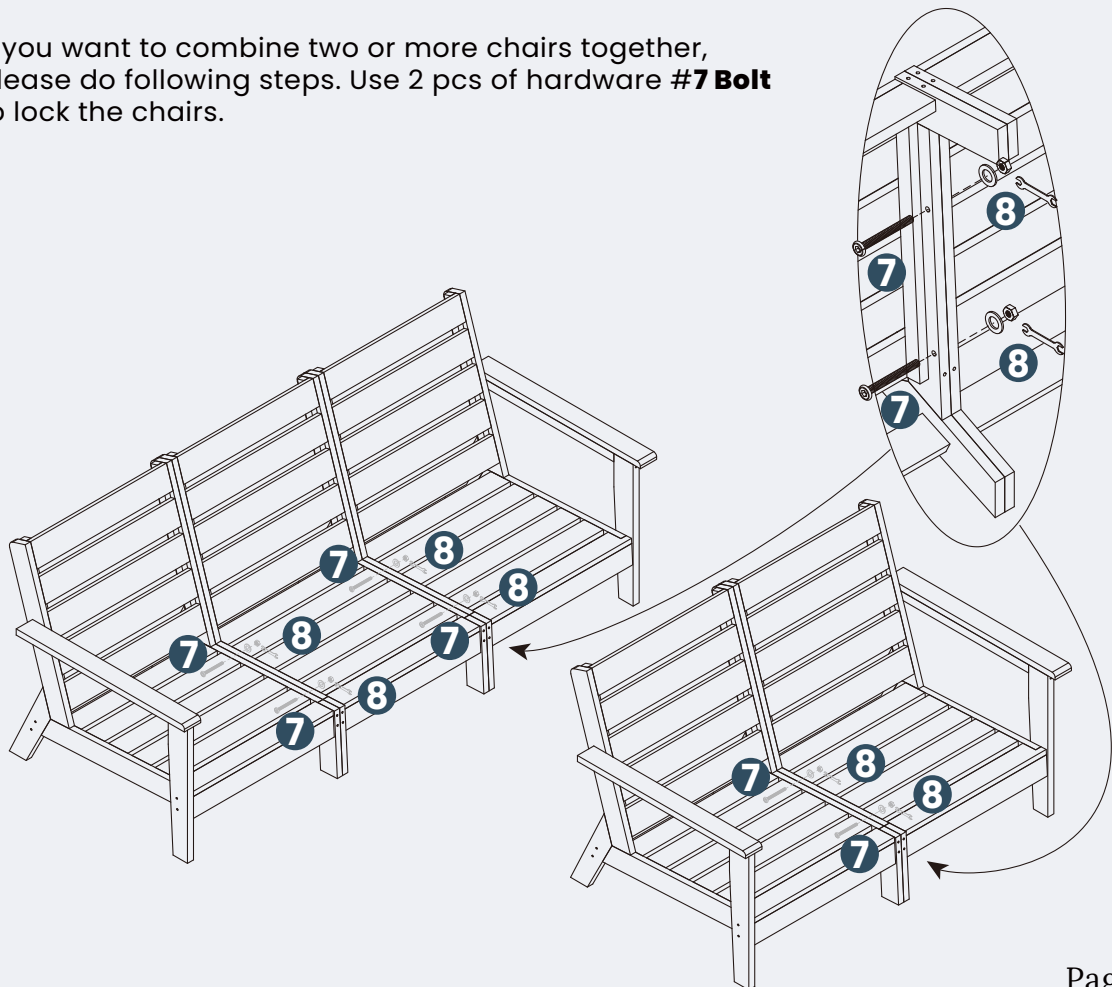

INSTRUCTION MANUAL

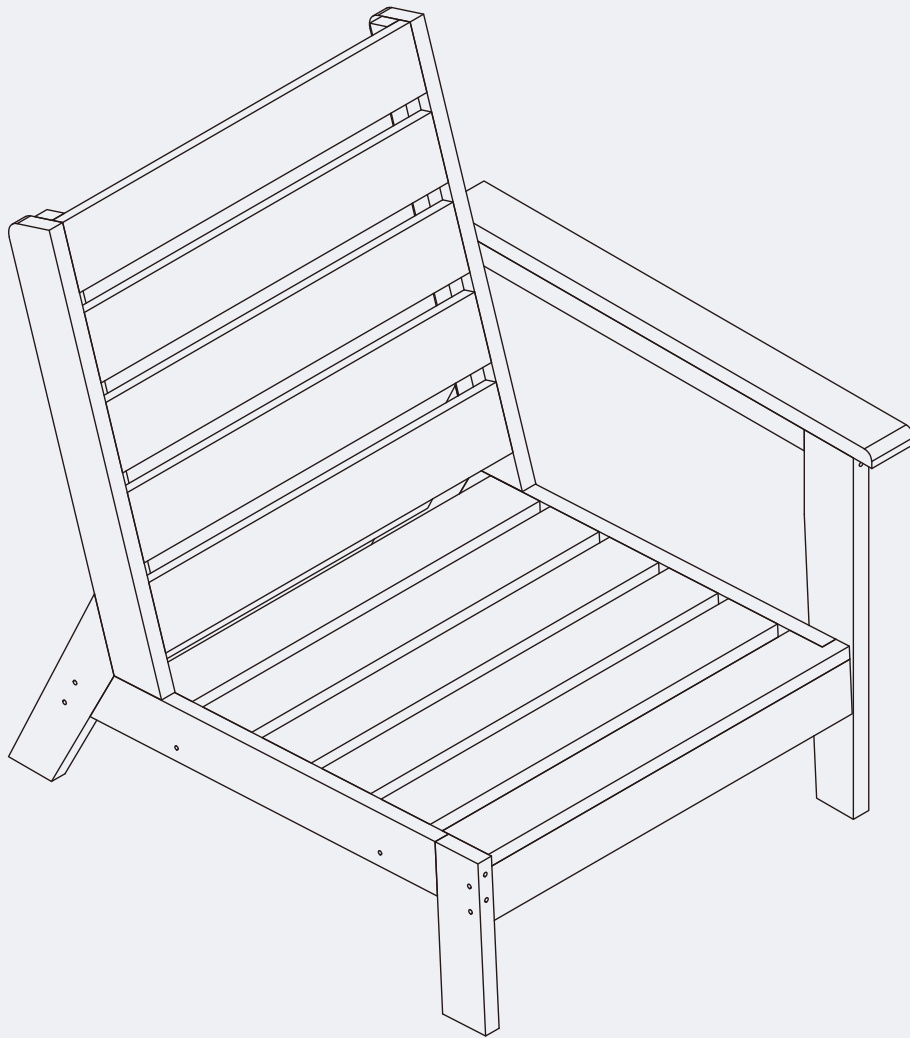

Deep Seating Left Arm Chair

! CARE & MAINTENANCE

Please keep these instructions for your future reference.

- Be careful when assembling to avoid damaging the plating of the surface.
- Clean the chair with lukewarm water, mild detergent, & soft cloth.
- Firmly secure all bolts before use. Do not use any part of this item as a step ladder.
- Make sure that all bolts, screws, and nuts are secure every 90 days..
- Do not use or store this item in the proximity of open flame or flammable/combustible chemicals.
- Be aware that some parts are heavy and have sharp edges.
- Do not overtighten screws (insert all screws before tightening screws).

TOOLS REQUIRED

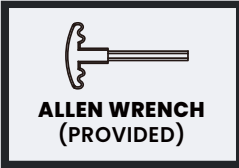

**330 LBS
CAPACITY**



**2 PERSON
ASSEMBLY**



**UP TO 30 MIN.
ASSEMBLY**

HARDWARE

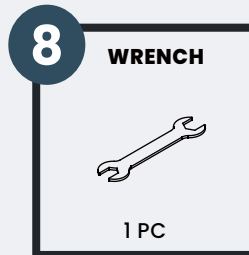
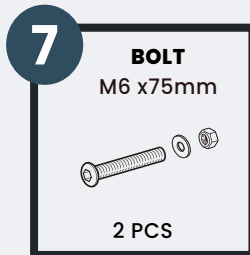
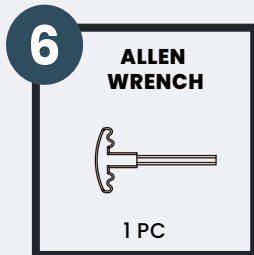
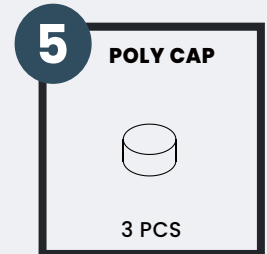
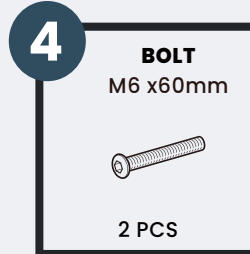
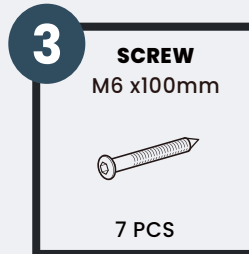
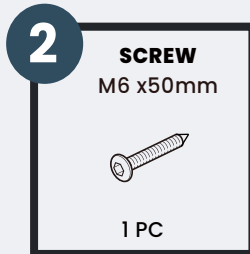
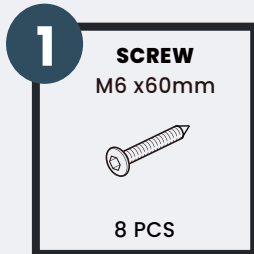

PARTS

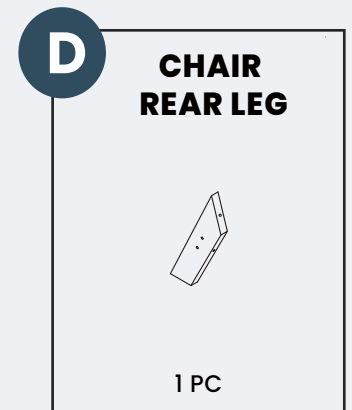
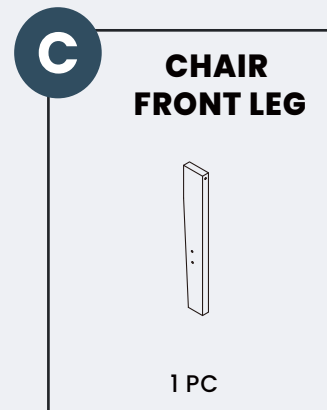
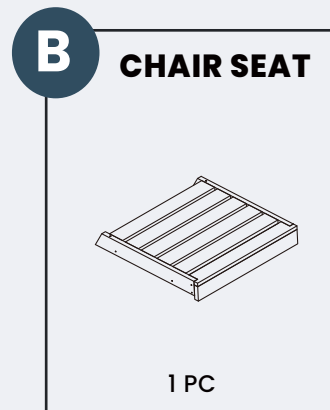
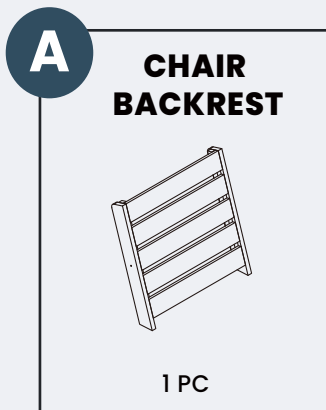

PARTS

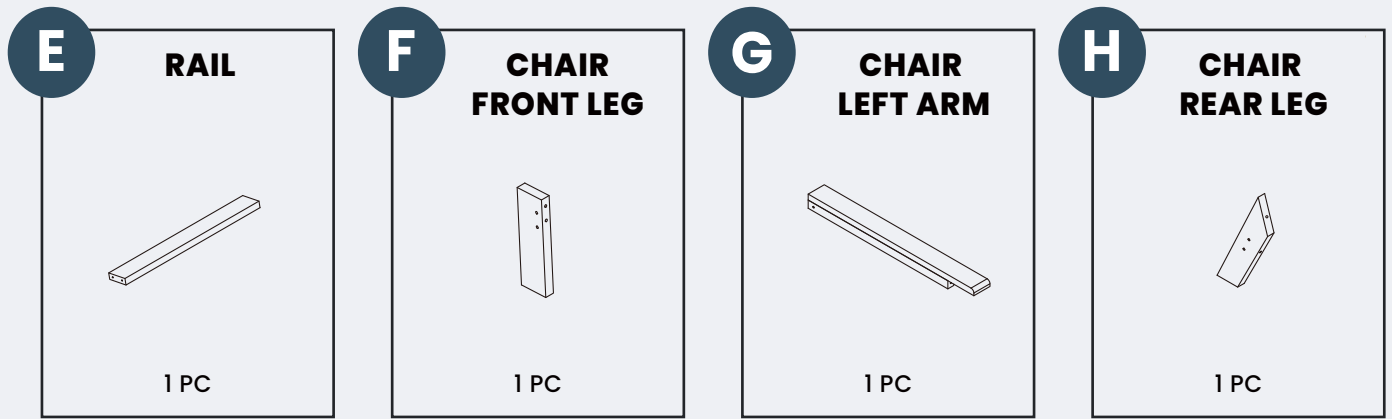

PRODUCT ASSEMBLY - OVERALL VIEW

Look at following overall view of this chair and learn the exact position of each parts to be assembled.

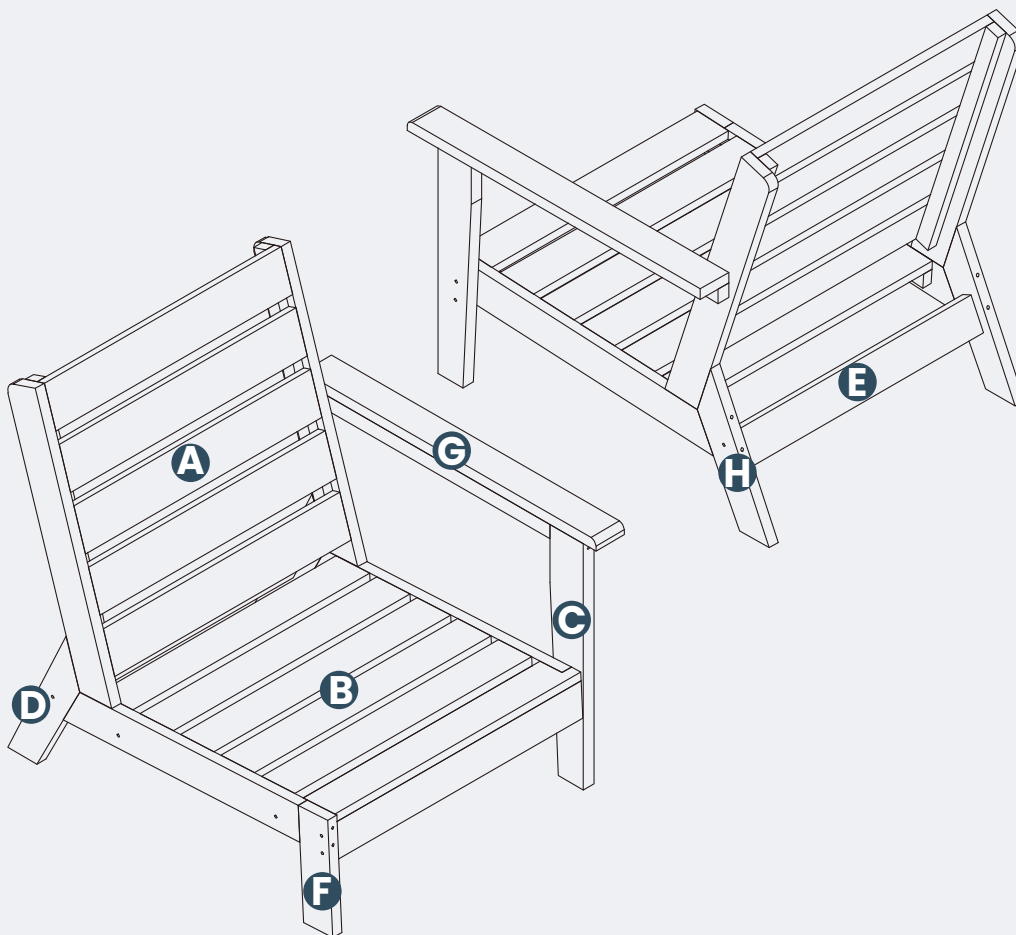

PRODUCT ASSEMBLY

1

Attach **part E Rail** to **part D** and **part H Rear Leg** with 4 pcs of hardware **#1 Screw**.

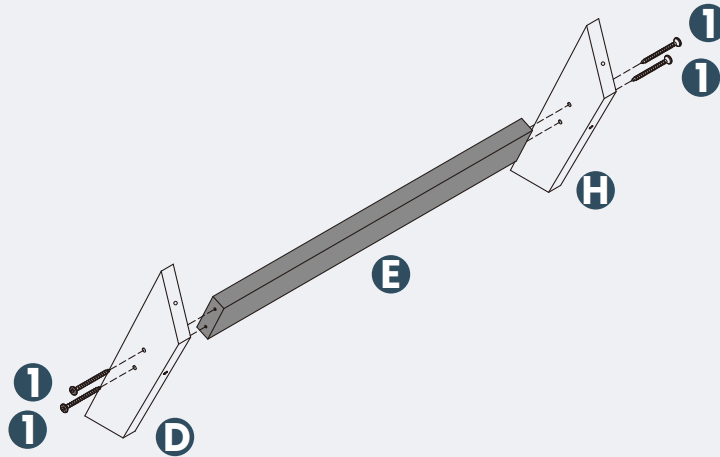

PRODUCT ASSEMBLY

2

Attach **part D** and **part H Rear Leg** to **part B Seat** with 2 pcs of hardware **#3 Screw**.
Attach **part C Front Leg** to **part B Seat** with 2 pcs of hardware **#4 Bolt**.
Attach **part F Front Leg** to **part B Seat** with 2 pcs of hardware **#1 Screw**.

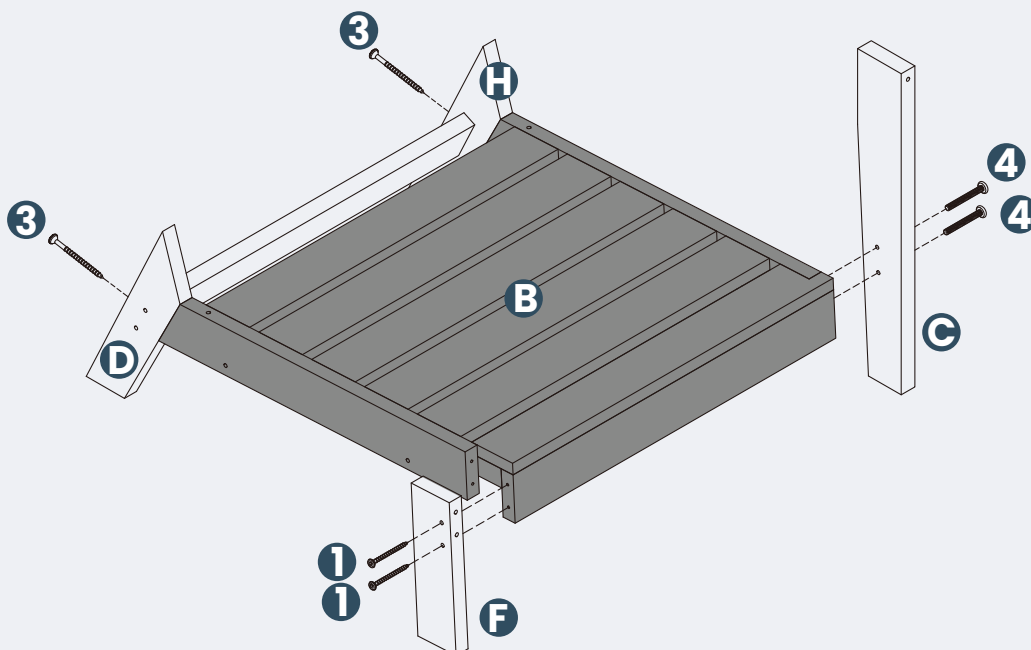

PRODUCT ASSEMBLY

3

Attach **part A Backrest** to **part B Seat** with 2 pcs of hardware **#3 Screw**.
Attach **part D** and **part H Rear Leg** to **part A Backrest** with 2 pcs of hardware **#1 Screw**.
Attach **part F Front Leg** to **part B Seat** with 2 pcs of hardware **#3 Screw**.

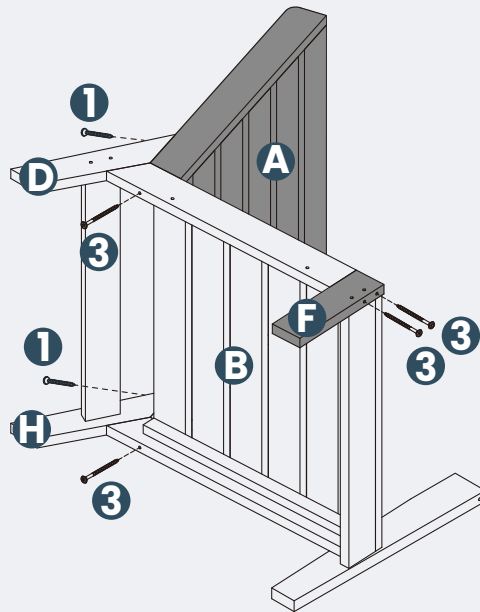

4

Attach **part G Left Arm** to **part A Backrest** with 1 pc of hardware **#2 Screw**.
Attach **part G Left Arm** to **part C Front Leg** with 1 pc of hardware **#3 Screw**.

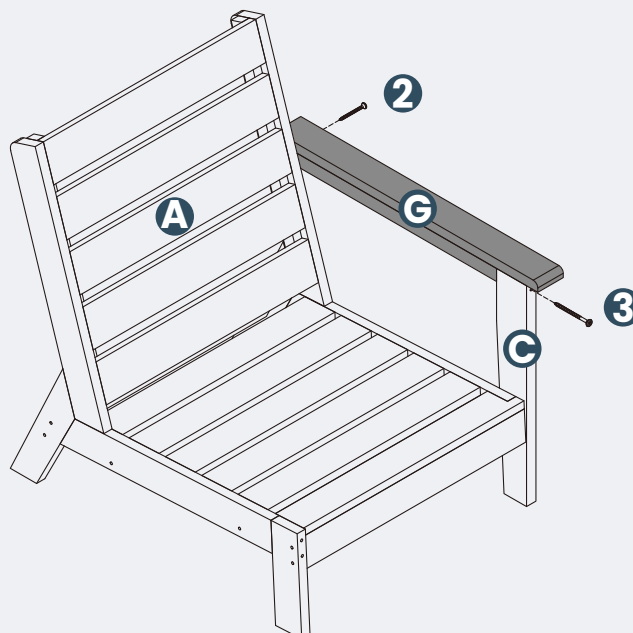

PRODUCT ASSEMBLY

5

The poly cap here is not easy to remove after being plugged in, and may cause the arm and front leg to be hard to disassemble. Please pay attention and decide whether you really need this poly cap or not during assembly.

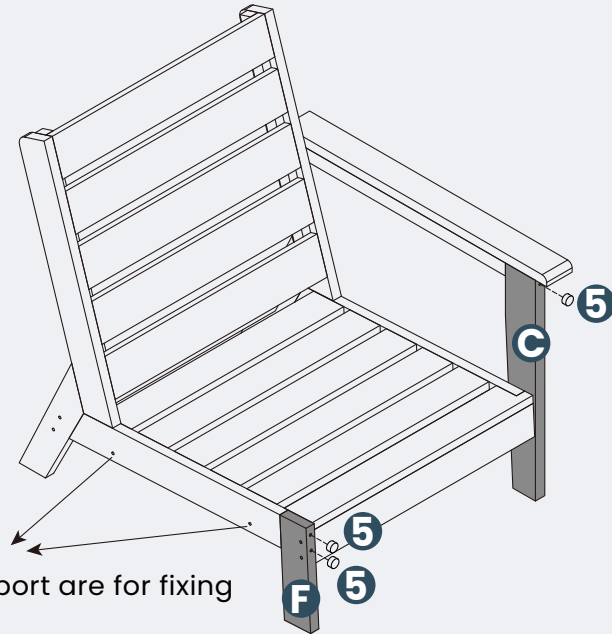

The holes on the seat support are for fixing the chair to other chairs.

6

If you want to combine two or more chairs together, please do following steps. Use 2 pcs of hardware #7 Bolt to lock the chairs.

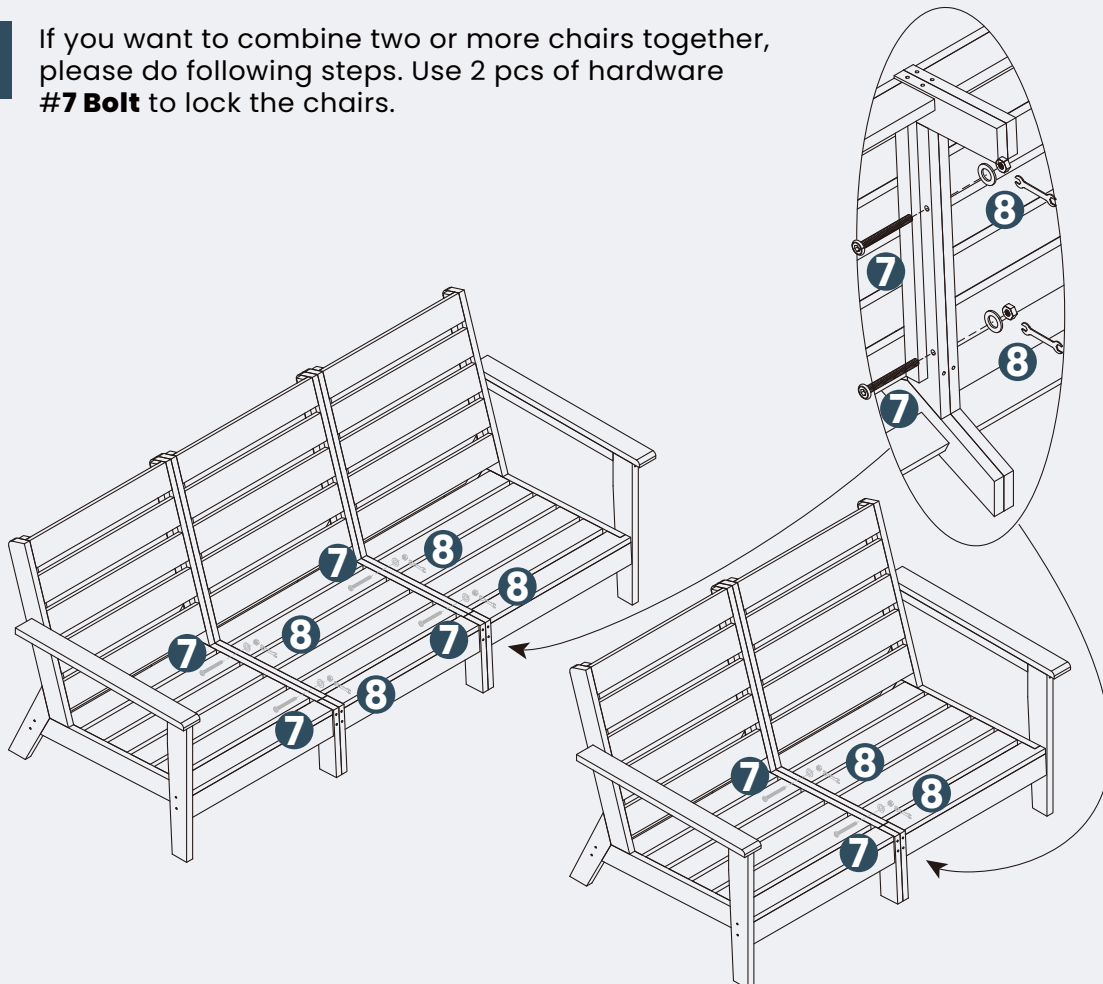

INSTRUCTION MANUAL

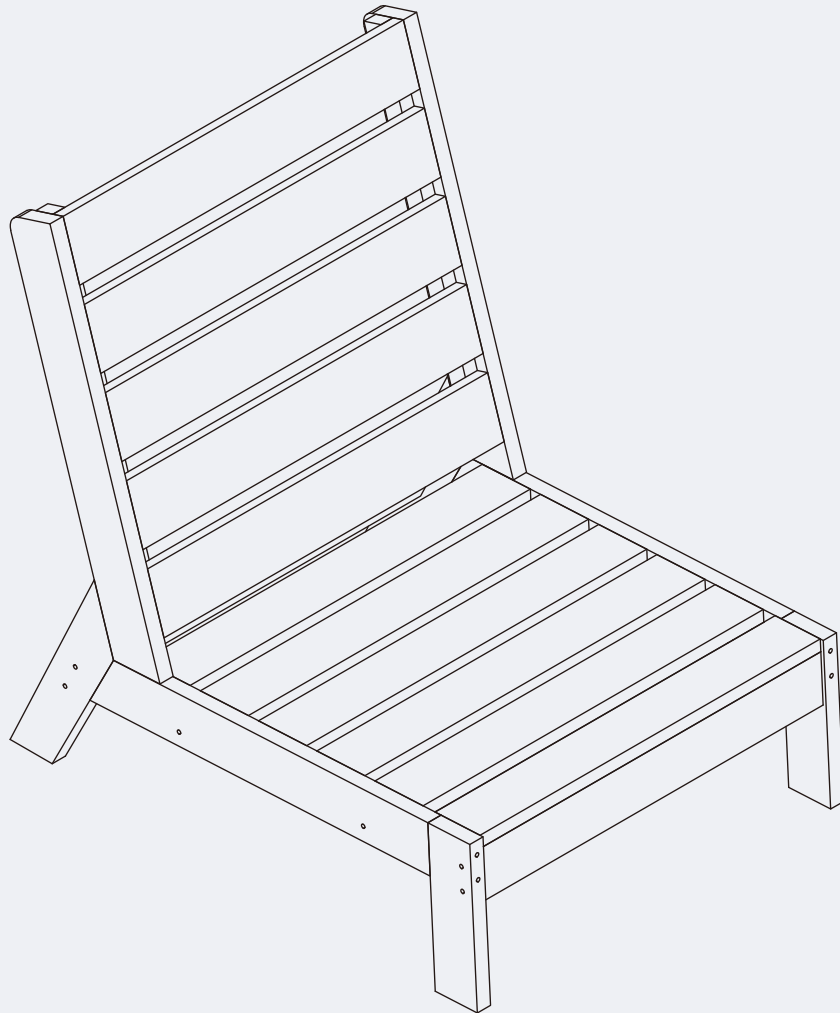

Deep Seating Armless Chair

! CARE & MAINTENANCE

Please keep this instruction for your future reference.

- Be careful when assembling to avoid damaging the plating of the surface.
- Clean the chair with lukewarm water, mild detergent & soft cloth.
- Firmly secure all bolts before use. Do not use any part of this item as a step ladder.
- Make sure that all bolts, screws, and nuts are secure every 90 days.
- Do not use or store this item in the proximity of open flame or flammable/combustible chemicals.
- Be aware that some parts are heavy and have sharp edges.
- Do not overtighten screws (insert all screws before tightening screws).

TOOLS REQUIRED

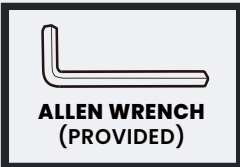

**330 LBS
CAPACITY**



HARDWARE

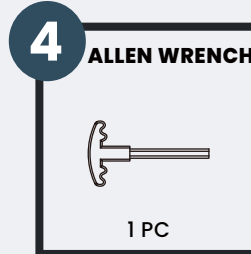
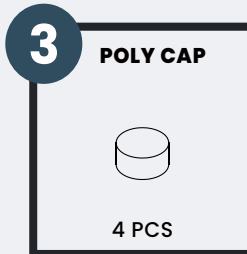
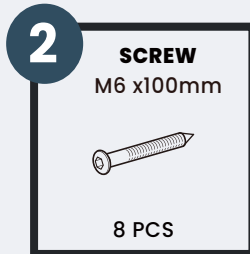
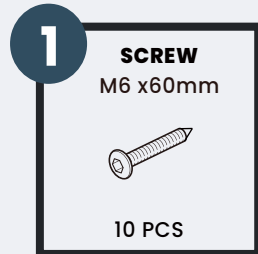

PARTS

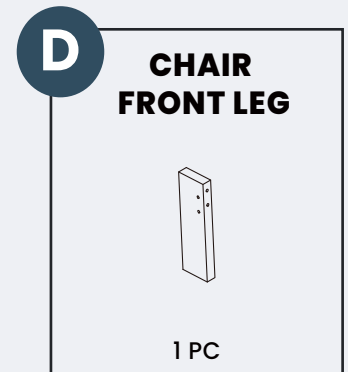
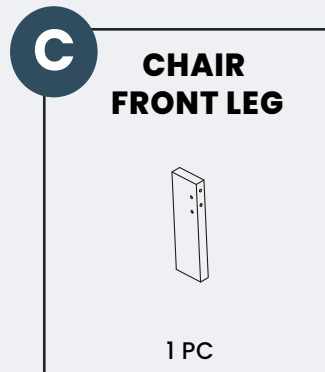
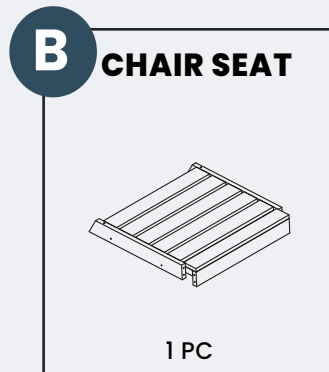
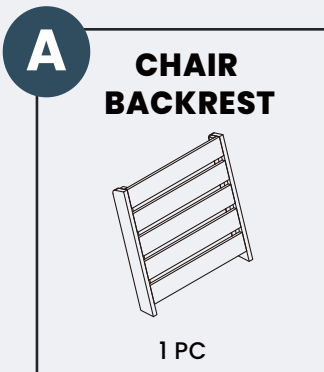

PARTS

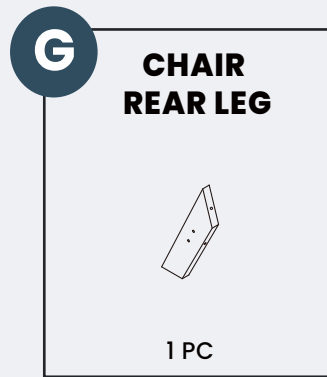
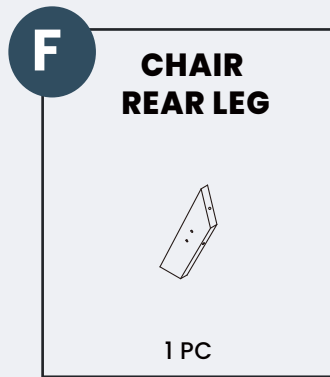
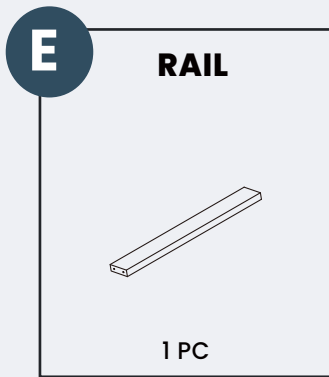

PRODUCT ASSEMBLY - OVERALL VIEW

Look at following overall view of this chair and learn the exact position of each parts to be assembled.

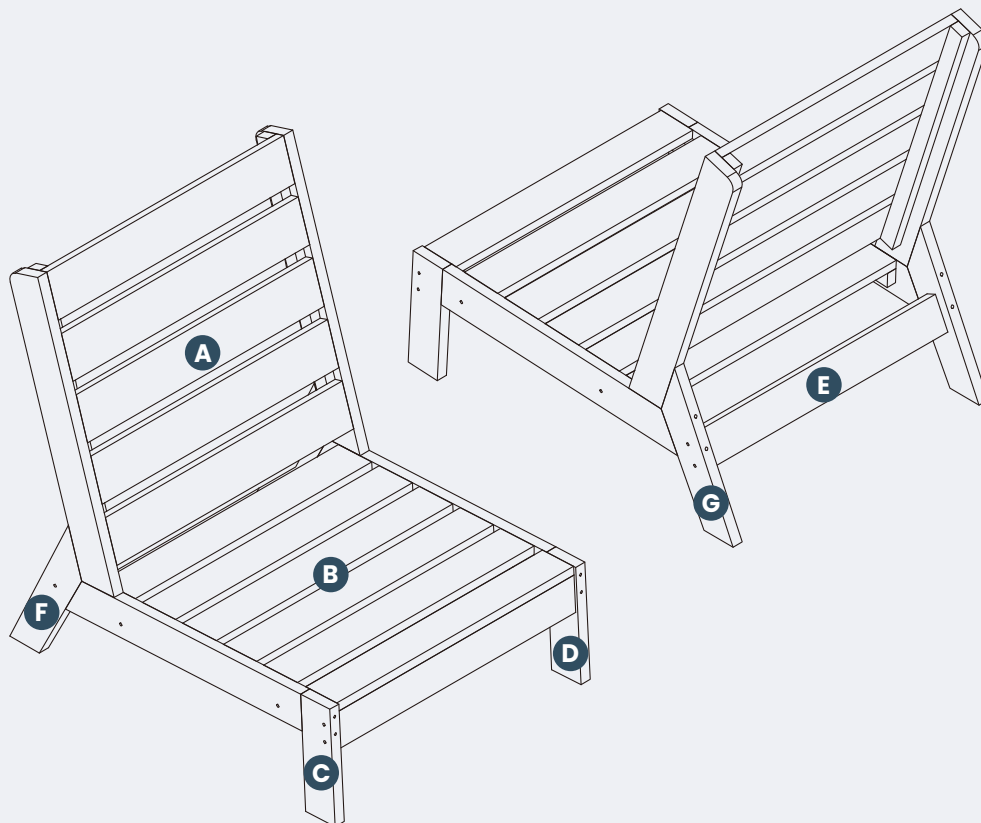

PRODUCT ASSEMBLY

1

Attach **part E Rail** to **part F** and **part G Rear Leg** with 4 pcs of hardware **#1 Screw**.

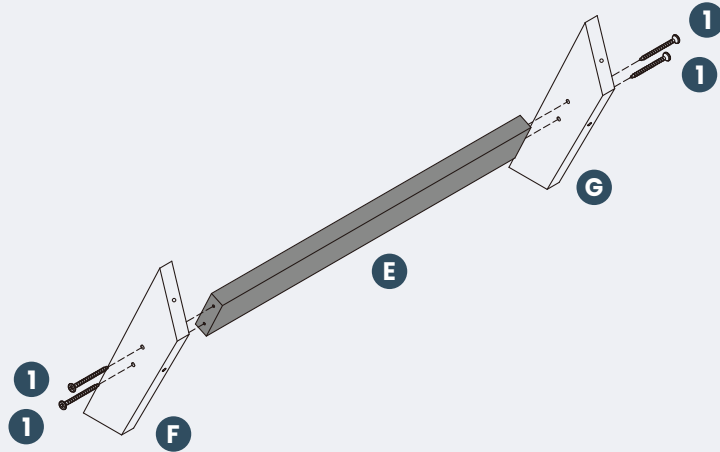

2

Attach **part F** and **part G Rear leg** to **part B Seat** with 2 pcs of hardware **#2 Screw**.
Attach **part C** and **part D Front leg** to **part B Seat** with 4 pcs of hardware **#1 Screw**.

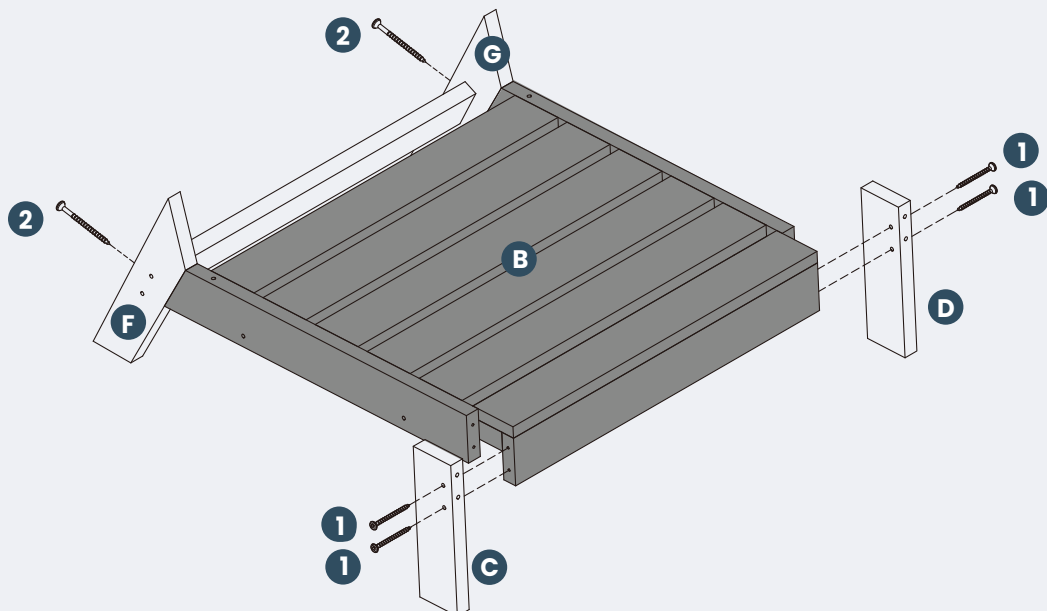

PRODUCT ASSEMBLY

3

Attach **part A Backrest** to **part B Seat** with 2 pcs of hardware **#2 Screw**.
Attach **part F** and **part G Rear leg** to **part A Backrest** with 2 pcs of hardware **#1 Screw**.

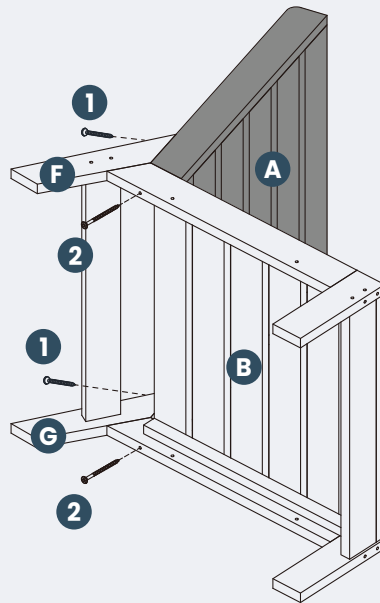

4

Attach **part C** and **part D Front leg** to **part B Seat** with 4 pcs of hardware **#2 Screw**.

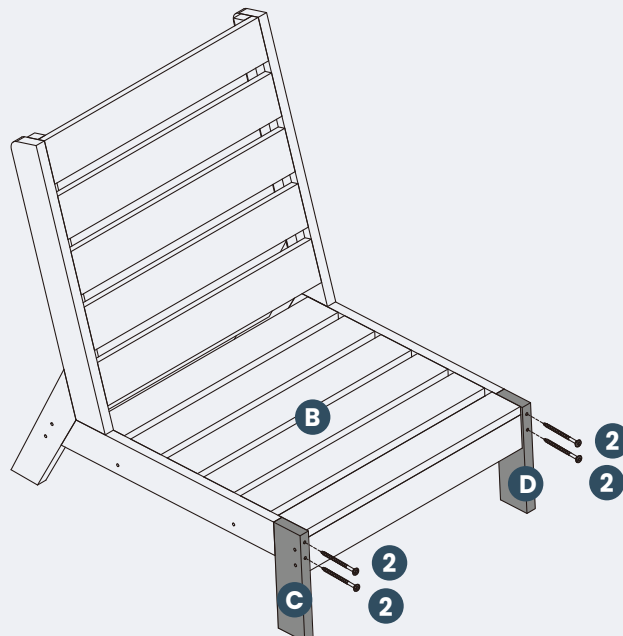

PRODUCT ASSEMBLY

5

The poly cap here is not easy to remove after being plugged in, and may cause the arm and front leg to be hard to disassemble. Please pay attention and decide whether you really need this poly cap or not during assembly.

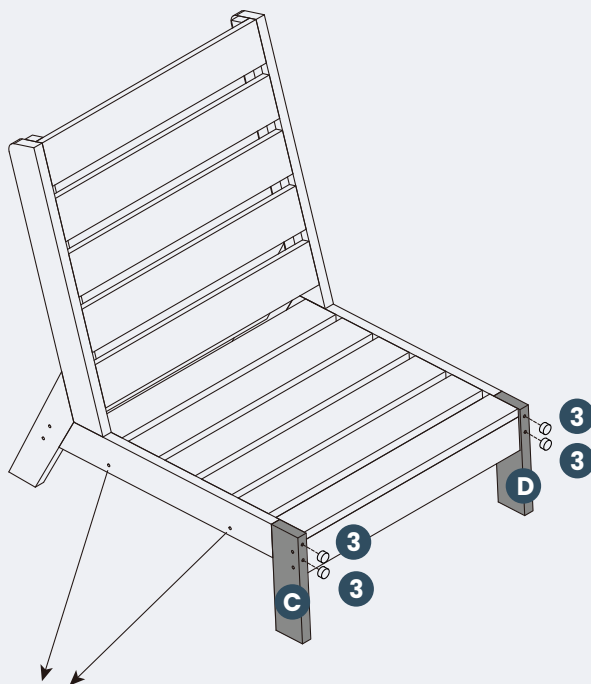

The holes on the seat support are for fixing the chair to other chairs.

6

If you want to combine two or more chairs together, please do following steps. Use 2 pcs of hardware **#7 Bolt** to lock the chairs.

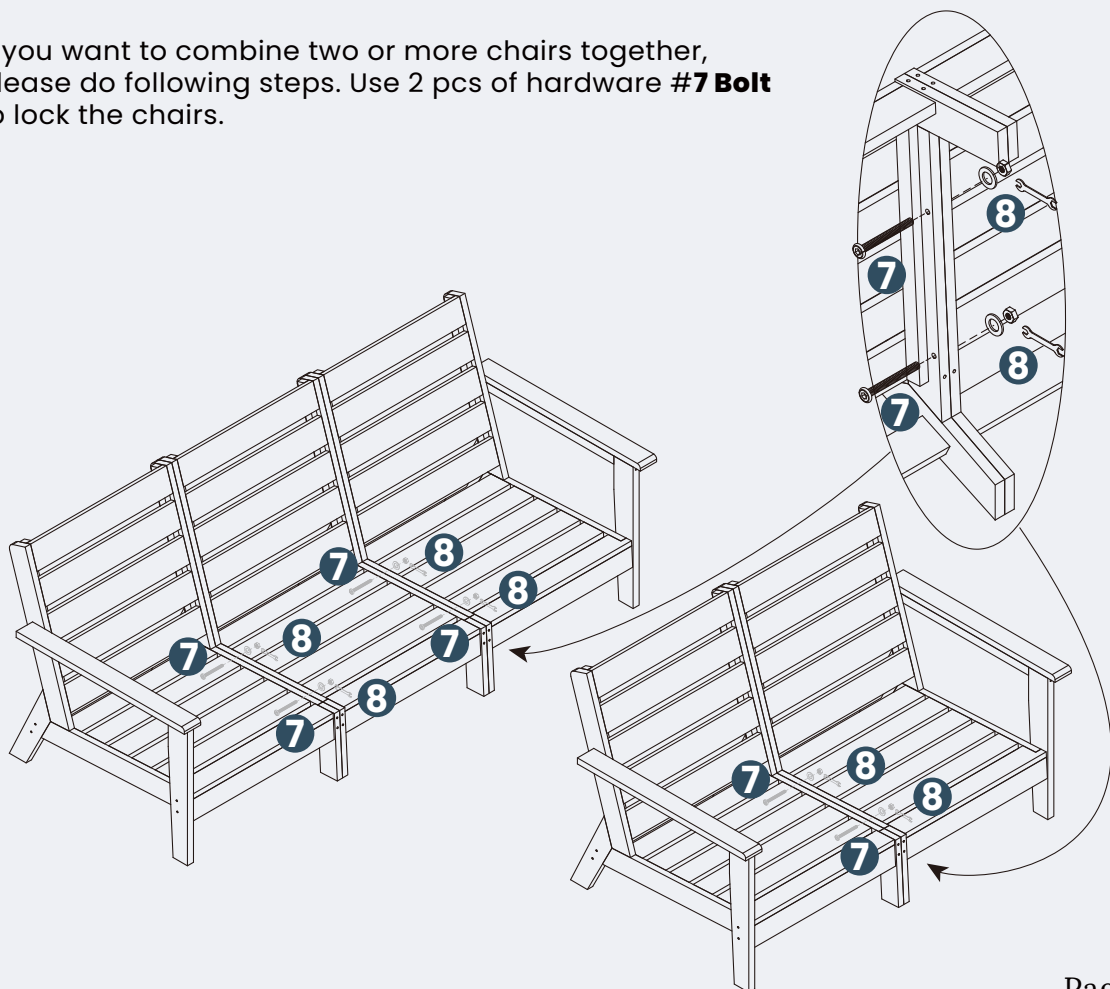

INSTRUCTION MANUAL

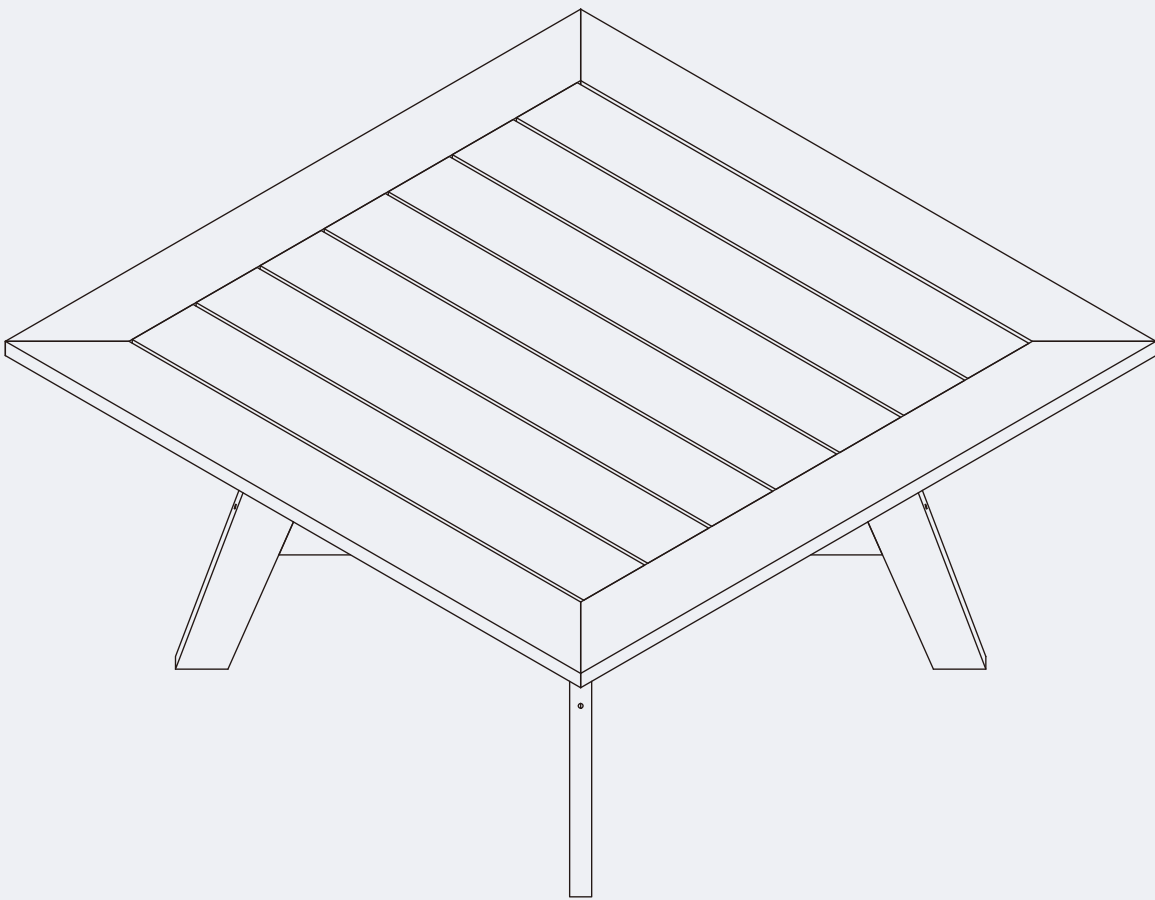

37" Conversation Table

! CARE & MAINTENANCE

Please keep this instruction for your future reference.

- Be careful when assembling to avoid damaging the plating of the surface.
- Clean the chair with lukewarm water, mild detergent & soft cloth.
- Firmly secure all bolts before use. Do not use any part of this item as a step ladder.
- Make sure that all bolts, screws, and nuts are secure every 90 days.
- Do not use or store this item in the proximity of open flame or flammable/combustible chemicals.
- Be aware that some parts are heavy and have sharp edges.
- Do not overtighten screws (insert all screws before tightening screws).

TOOLS REQUIRED

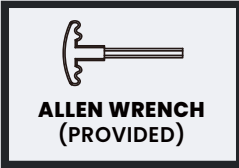

**300 LBS
CAPACITY**



**2 PERSON
ASSEMBLY**



**UP TO 30 MIN.
ASSEMBLY**

HARDWARE

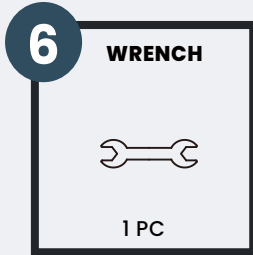
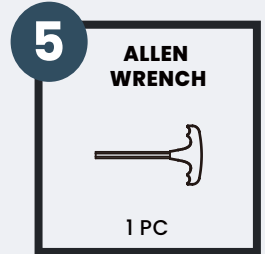
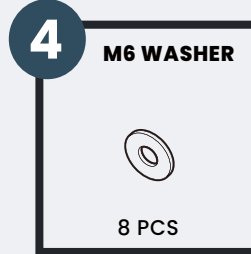
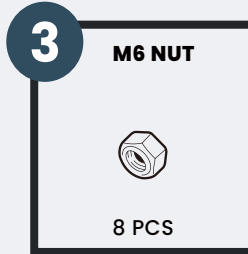
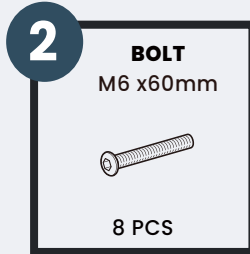
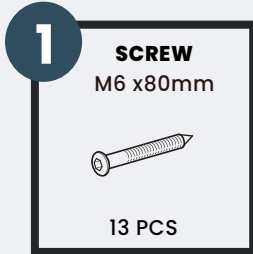

PARTS

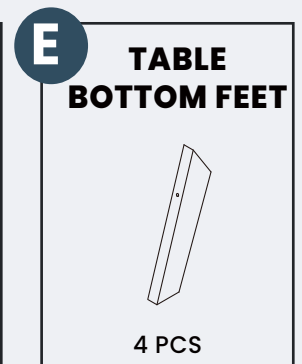
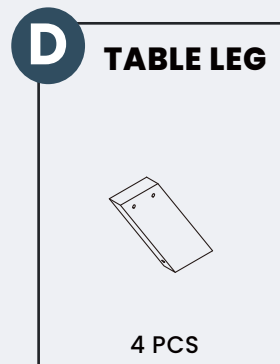
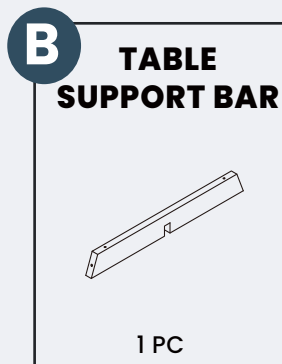
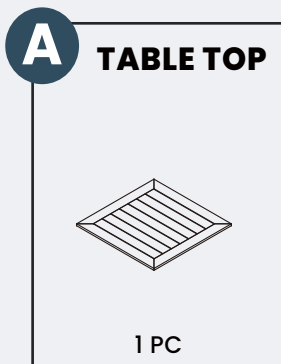

PRODUCT ASSEMBLY – OVERALL VIEW

Look at following overall view of this table and learn the exact position of each parts to be assembled.

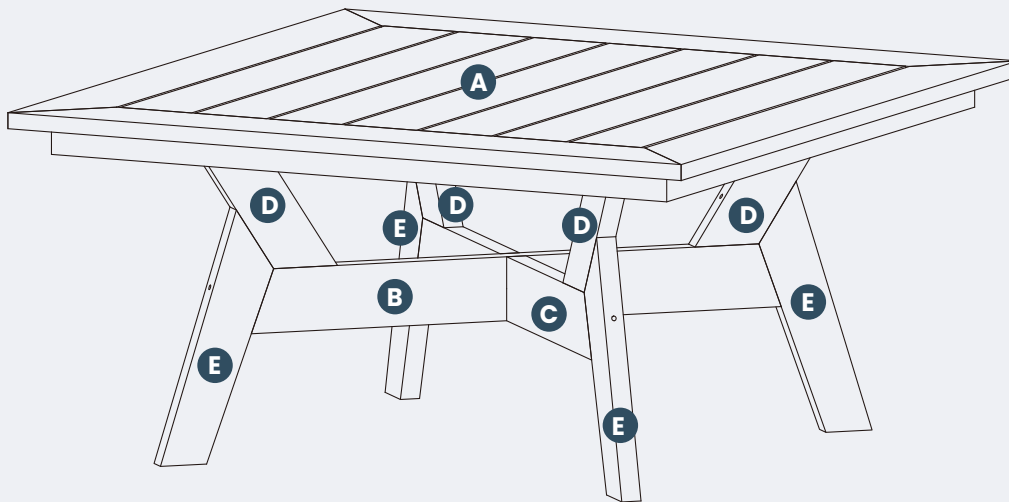

PRODUCT ASSEMBLY

1

Attach **part E Bottom Feet** to **part B Support Bar** with 2 pcs of hardware **#1 Screw**.
Attach **part D Leg** to **part E Bottom Feet** with 2 pcs of hardware **#1 Screw**.
Attach **part D Leg** to **part B Support Bar** with 2 pcs of hardware **#1 Screw**.

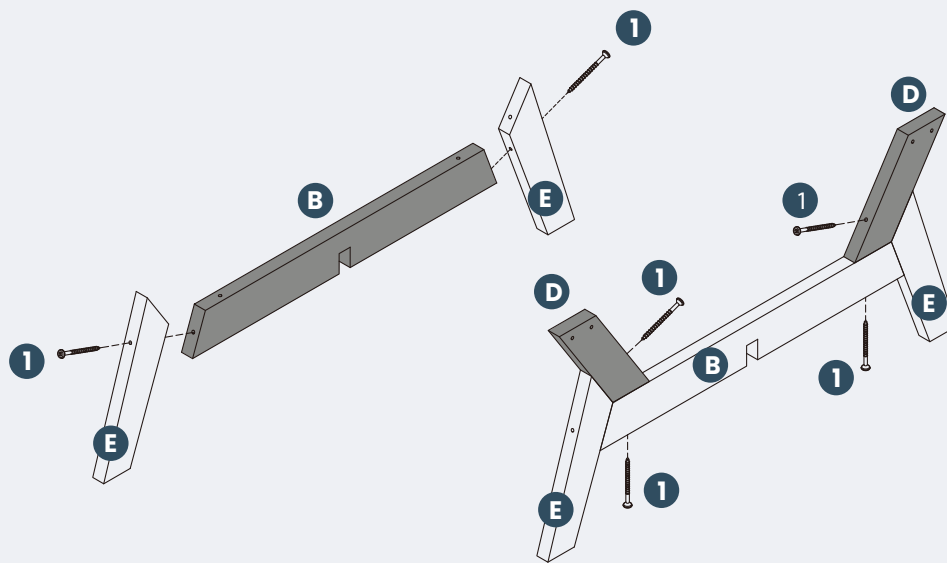

PRODUCT ASSEMBLY

2

Attach **part E Bottom feet** to **part C Support Bar** with 2 pcs of hardware **#1 Screw**.

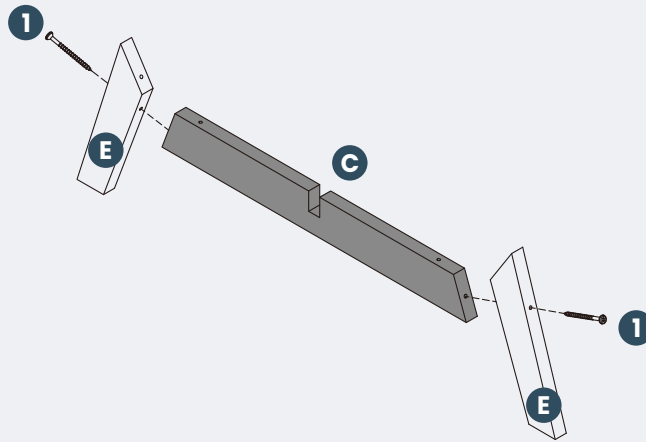

3

Attach **part D Leg** to **part E Bottom Feet** with 2 pcs of hardware **#1 Screw**.
Attach **part D Leg** to **part C Support Bar** with 2 pcs of hardware **#1 Screw**.

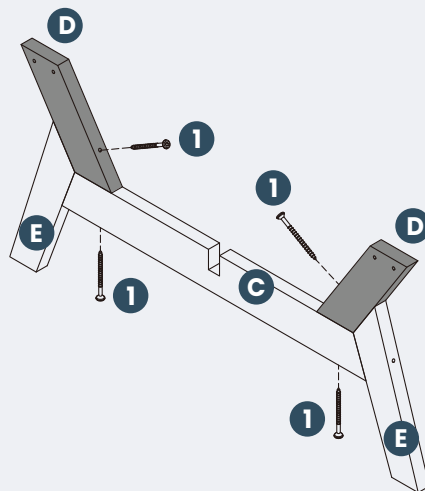

PRODUCT ASSEMBLY

4

Attach **part D Leg** with **Support Bar B** to **part A Table Top** with 4 sets of hardware **#2 Bolt**, hardware **#4 Washer** and hardware **#3 Nut**.

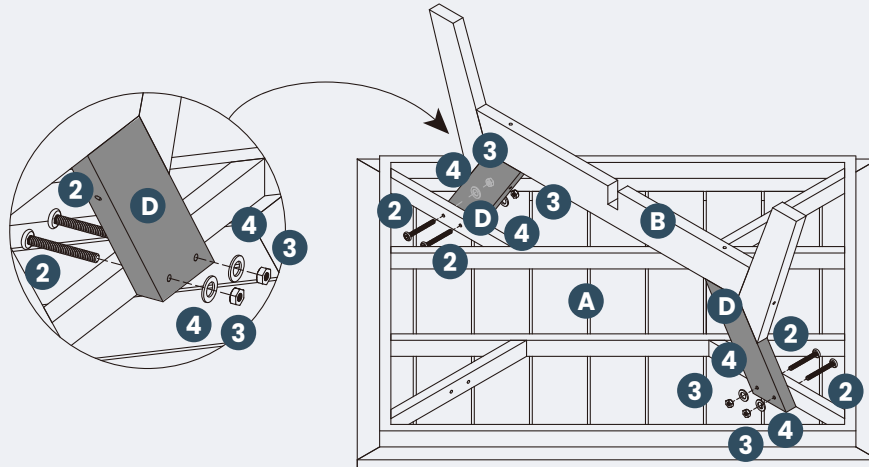

5

Attach **part C Support Bar** to **part B Support Bar** with 1 pcs of hardware **#1 Screw**.

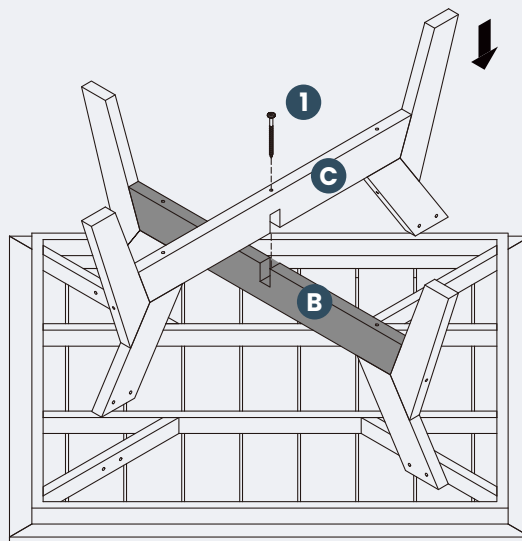

PRODUCT ASSEMBLY

6

Attach **part D** with **Support Bar C** to **part A Table Top** with 4 sets of hardware **#2 Bolt**, hardware **#4 Washer**, and hardware **#3 Nut**.

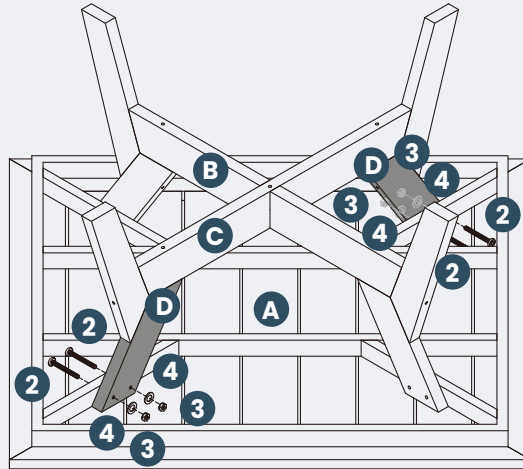

7

Check and tighten all the bolts and screws again and finish the assembly.

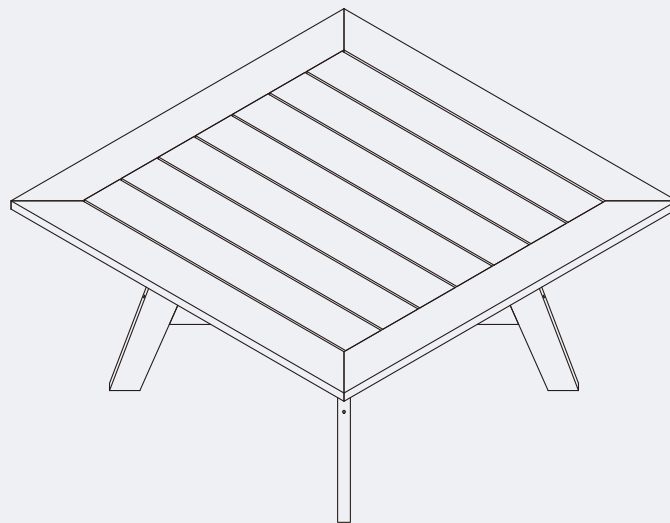

CLEANING TIPS

REGULAR CLEAN: Use a mixture of warm water and mild soap. Gently scrub the surface with a soft bristle brush to remove any dirt or stains.

QUICK CLEAN: You can simply wipe down the furniture with a damp cloth.

Regular cleaning not only preserves the aesthetic appeal of your furniture, but also helps extend its lifespan.