

INSTRUCTION MANUAL

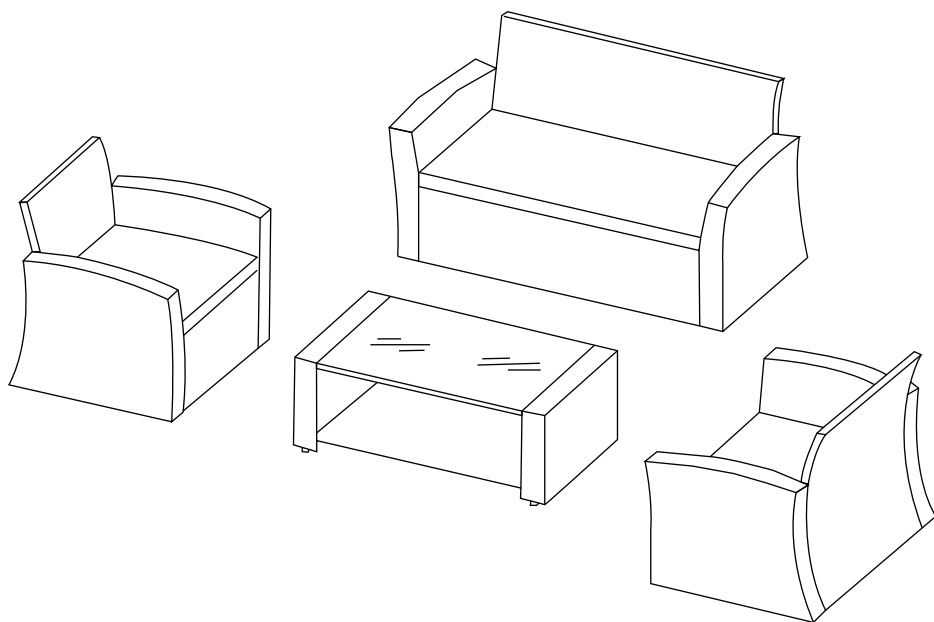

**4-Piece Conversation Outdoor
Patio Sofa Set with Cushions
SKU: 1101**

! NOTICE

Do not overtighten screws. (Insert all screws before tighten screws.)

- Please do not exceed the weight limitations of this item.
- Do not stand on or use any part of this item as a step ladder.
- Firmly secure all bolts, screws and nuts before use.
- Reconfirm that all bolts, screws, and nuts are secure every 90 days.
- Do not use or store this item in the proximity of open flame or flammable/combustible chemicals.
- Be aware that some parts are heavy and have sharp edges.

TOOLS REQUIRED



ALLEN WRENCH
(PROVIDED)



TABLE
110 LBS
CAPACITY



LOVESEAT
660 LBS
CAPACITY



CHAIR
330 LBS
CAPACITY



2 PERSONS
ASSEMBLY



UP TO 60 MIN.
ASSEMBLY

HARDWARE

1

M6 WASHER



36 PCS

2

M6 x 35m
BOLT



36 PCS

3

ALLEN
WRENCH



1 PC

PARTS

A

LOVESEAT BACKREST

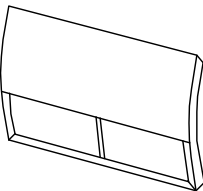

1 PC

B

RIGHT CHAIR SIDE

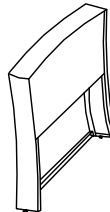

3 PCS

C

LONG SEAT

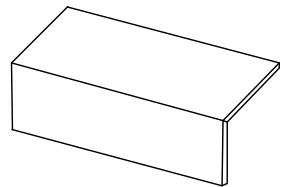

1 PC

PARTS

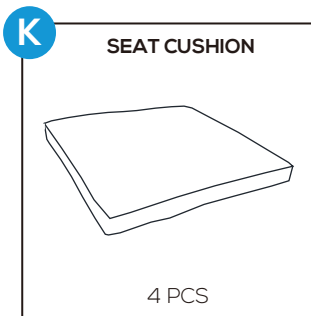
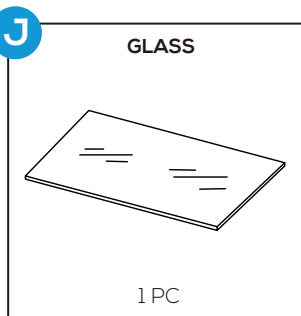
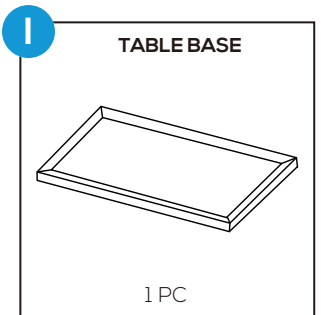
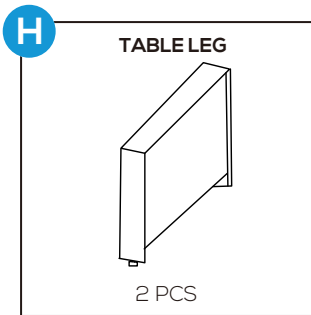
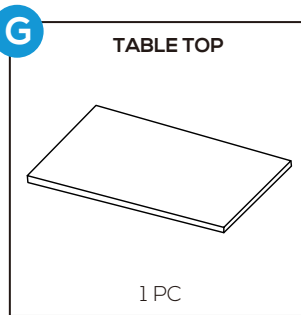
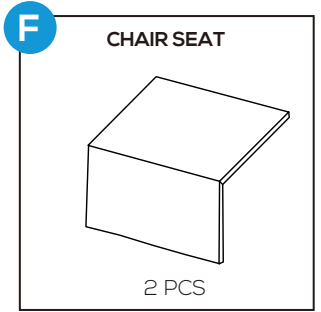
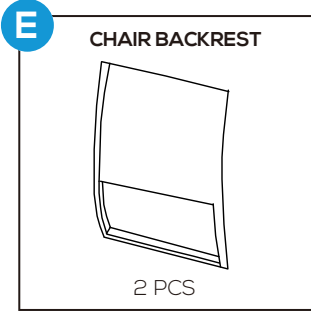
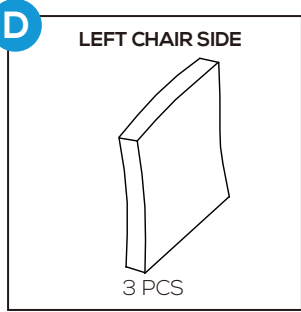

PRODUCT ASSEMBLY - LOVESEAT

1

Attach part C Long Chair Seat to part A Loveseat backrest with 2 PCS of part 1 washer and part 2 bolt. Do not tighten screws too much at this stage.

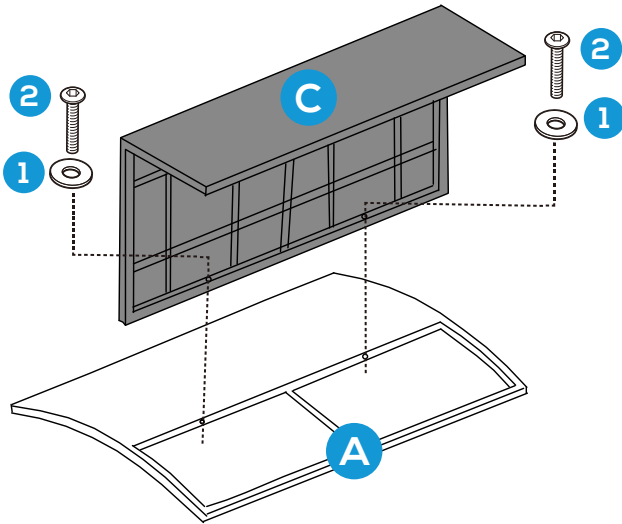

2

Attach part C Long Chair Seat and part A Loveseat backrest to part B chair right side with 4 PCS of part 1 washer and part 2 bolt.

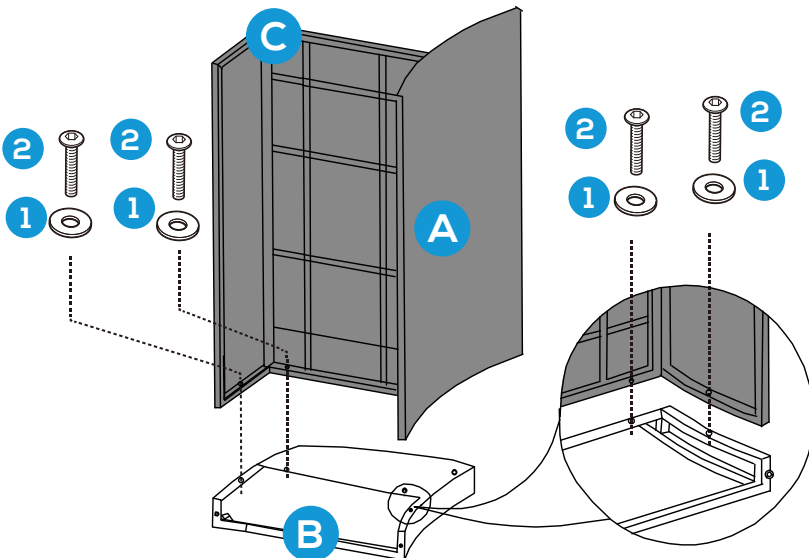

PRODUCT ASSEMBLY - LOVESEAT

3

Attach part C Long Chair Seat to part A Loveseat backrest with 2 PCS of part 1 washer and part 2 bolt.

Do not tighten screws too much at this stage.

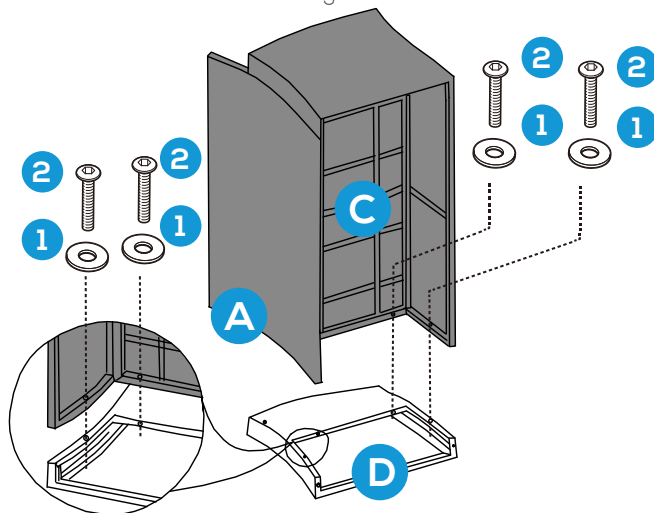

4

Tighten all bolts again to ensure this Loveseat is stable enough to use.

Place 2 PCS of part K cushion into the loveseat to finish the assembly.

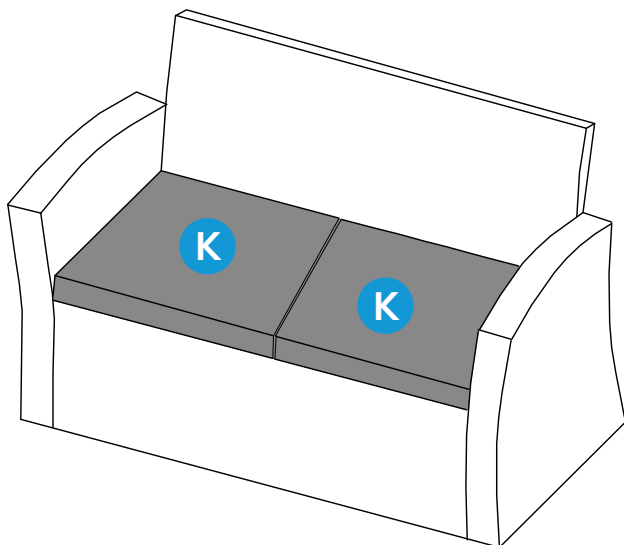

PRODUCT ASSEMBLY - CHAIR

1

Attach part F Chair Seat to part E Chair backrest with 1 PC of part 1 washer and part 2 bolt. Do not tighten screws too much at this stage.

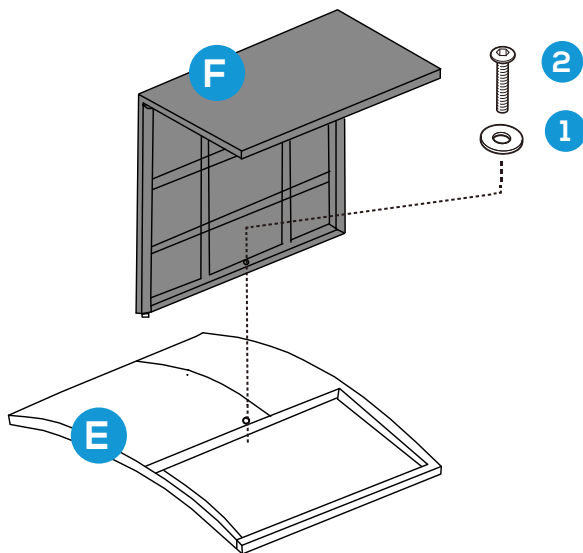

2

Attach part C Long Chair Seat and part A Loveseat backrest to part B chair right side with 4 PCS of part 1 washer and part 2 bolt.

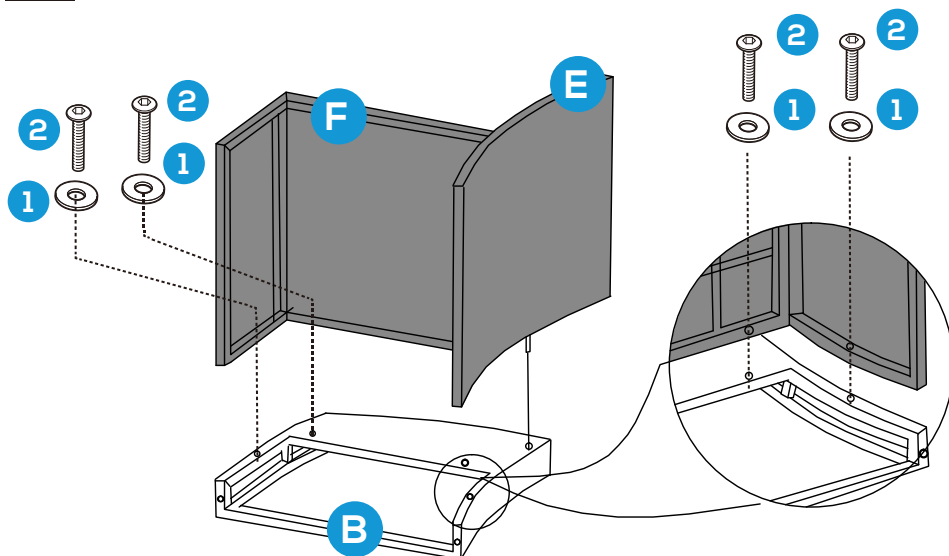

PRODUCT ASSEMBLY - CHAIR

3

Attach part F Chair Seat and part E Chair backrest to part D left chair side with 4 PCS of part 1 washer and part 2 bolt.

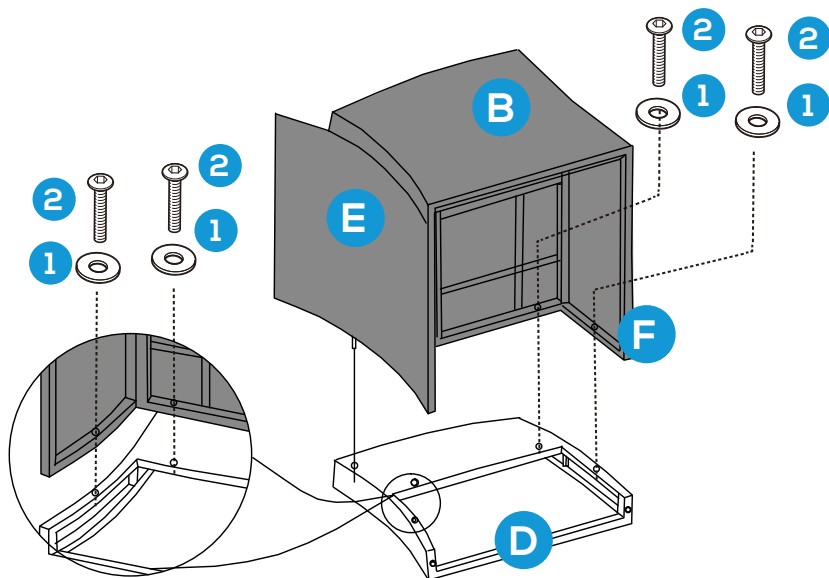

4

Tighten all bolts again to ensure this Loveseat is stable enough to use.

Place 1 PC of part K cushion into the chair to finish the assembly.

Repeat steps to assemble another chair.

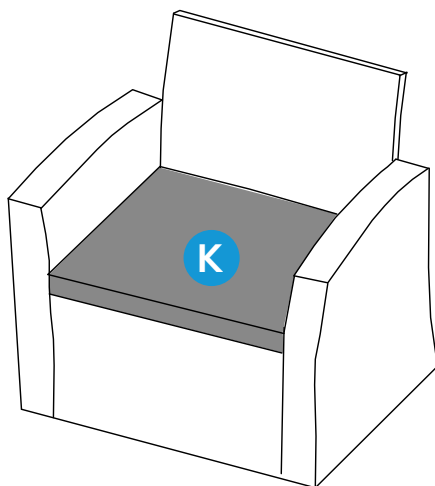

PRODUCT ASSEMBLY - COFFEE TABLE

1

Attach part H Table Leg to part G Table Base with 4 PCS of part 1 washer and part 2 bolt.

Do not tighten screws too much at this stage.

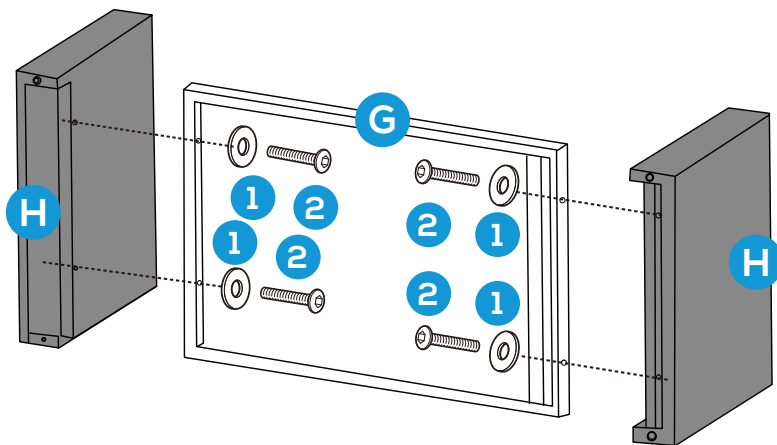

2

Attach part I desk top to the legs with 4 PCS of part 1 washer and part 2 bolt.

Tighten all bolts again to ensure this coffee table is stable enough to use.

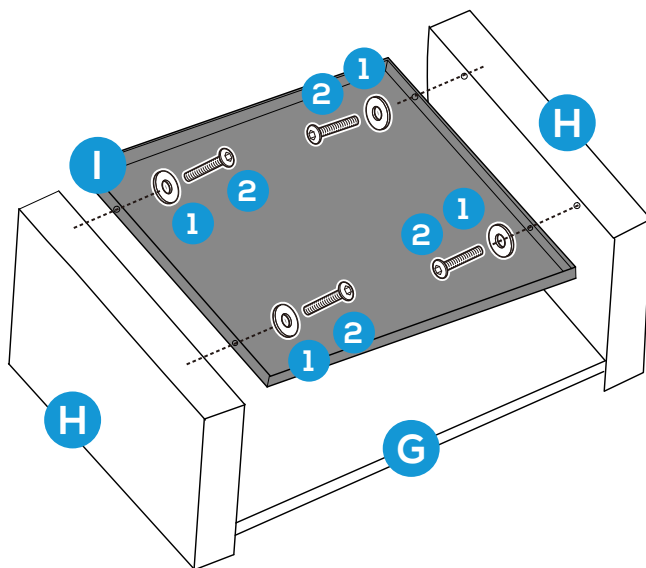

PRODUCT ASSEMBLY - COFFEE TABLE

3

Put part J the top glass onto the top of desk.

The Assembly finishes.

