

Thank you for purchasing Leick Furniture products.
Contact customer service for comments or concerns.

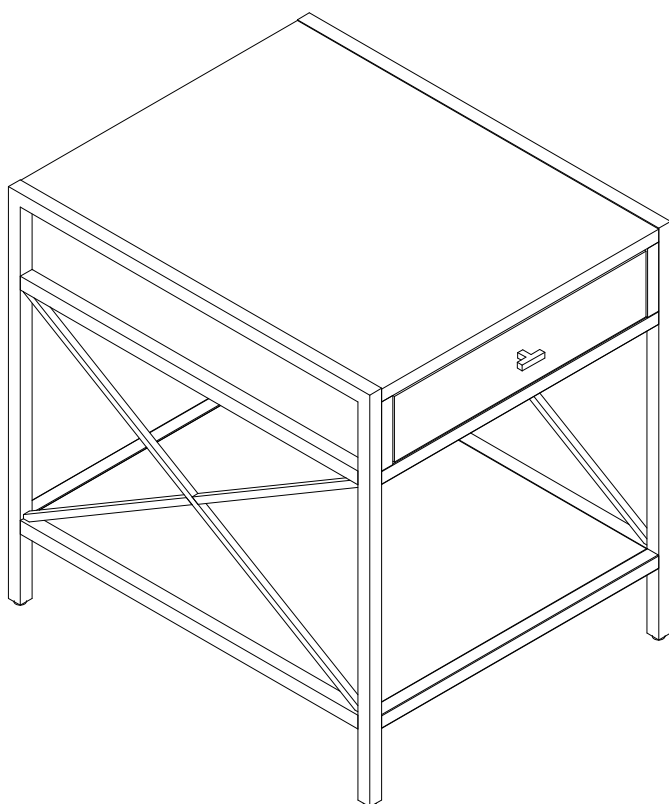





Assembly Instructions, #9206 Claudette End Table

Note:

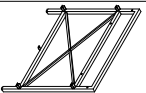
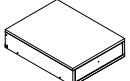
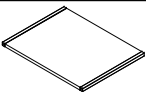
A packet with complete set of hardware can be found by pulling the red ribbon that's easily visible upon opening the box.

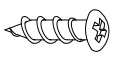

Parts List

A	Side Frames		2
B	Top Frames		1
C	Adjustable Shelf		1
D	Long Bolts		6
E	Short Bolts		8
F	Flat Washers		14
G	Allen Wrench		1
H	Door Pull		1
I	Machine Screw		1
J	Screws		2

Step 1

- 1.1) Lay 1 side frame (A) on a soft surface, put the top assembly (B) on, fit the metal parts into the side frame's tubes.
- 1.2) Fasten the top assembly's front and back bottom edges with 2 short bolts and washers.
- 1.3) Fasten the top assembly's side panel and back panel to the side frame with 3 long bolts and washers.

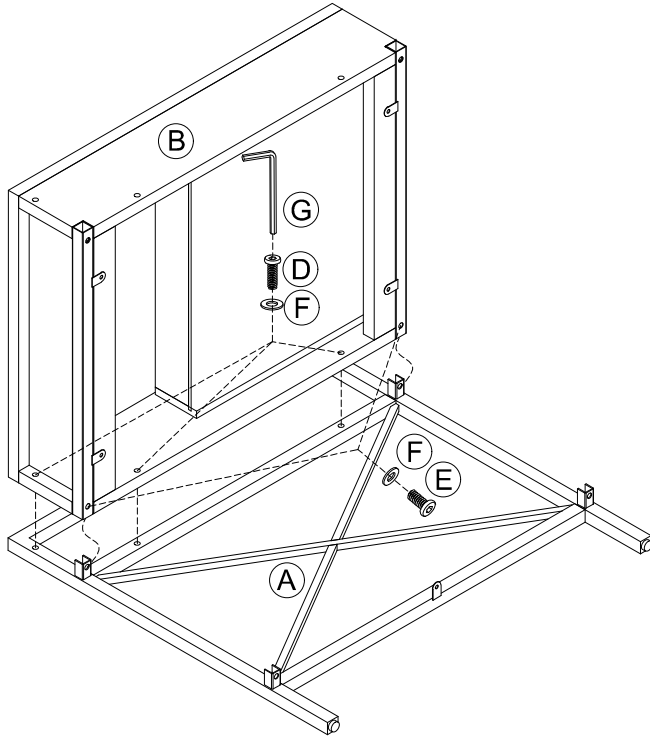

Step 2

- 2.1) Put the shelf (C) on with its metal tubes fitted into the side frame's assembly tubes. Fasten with 2 short bolts and 2 washers.

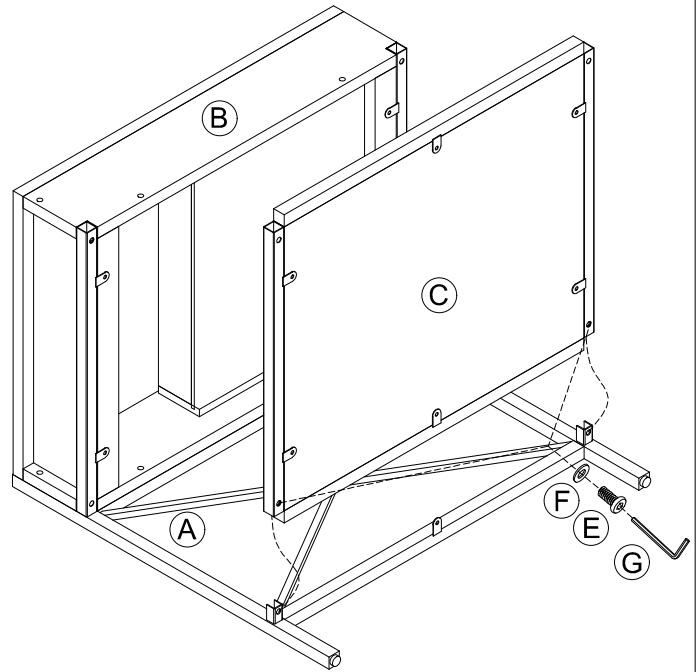

Step 3

- 3.1) Insert tubes of the other side frame to the side of top assembly (B) and shelf (C).
- 3.2) Push to make sure all tubes are properly inserted, fasten with 4 short bolts at the bottom of top assembly and shelf.
- 3.3) Fasten the top assembly to the left side frame with 3 long bolts and washers.
- 3.4) Fasten the shelf with 2 screws through the side frame's metal tabs on the bottom.

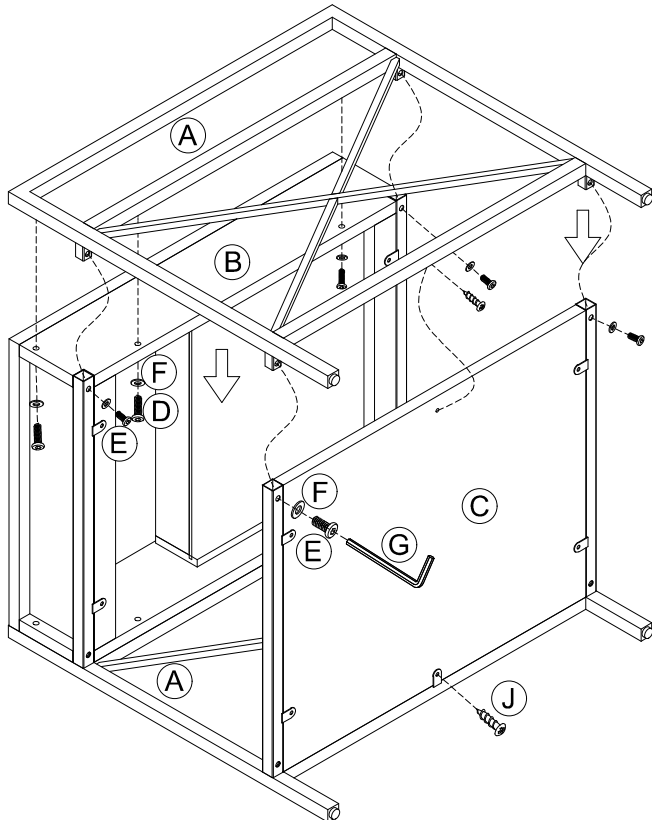

Step 4

- 4.1) Place the table upright. For your safety upon doing this process, flip it from the drawer side to keep from sudden and unintended opening.
- 4.2) Adjust the levelers at the bottom of legs if needed.
- 4.2) Fasten the drawer pull with 1 machine screw from inner face of drawer front. Check to ensure the drawer pull is properly aligned before tightening the machine screw.

