



Replace with LEDR56SCP/930CA type LED Light.
To order contact FEIT ELECTRIC COMPANY
Tel: 562-463-2852
Http: www.feit.com
Email: info@feit.com

INSTALLATION & OPERATING INSTRUCTIONS

READ & SAVE IMPORTANT SAFETY INSTRUCTIONS

Please read and understand this entire manual before attempting to assemble, operate or install this product.

1. This product must be installed in accordance with any applicable installation code(s) by a qualified electrician or person familiar with the construction and operation of the product and the hazards involved.
2. **RISK OF FIRE OR ELECTRIC SHOCK** : The electrical rating of this product is 120VAC.
3. **WARNING -RISK OF FIRE OR ELECTRIC SHOCK:** Install this product only in luminaires that have the construction features and dimensions shown in this manual.
4. **WARNING -** To prevent wiring damage or abrasion, do not expose wiring to edges of sheet metal or other sharp objects.
5. Do not make or alter any open holes in an enclosure of wiring or electrical components during installation.
6. **THIS DEVICE IS NOT INTENDED FOR USE WITH EMERGENCY EXITS**
7. **DANGER-RISK OF SHOCK-DISCONNECT POWER BEFORE INSTALLATION**
8. **DAMP LOCATION LISTED**

- | |
|---|
| <ul style="list-style-type: none">• Suitable for Type IC Housings• Suitable for Type Non-IC Housings |
|---|

CAUTION: to avoid possible electrical shock, be sure that power supply is turned off at fuse box or circuit breaker before installing or servicing fixture. For your safety, read and understand instructions completely before beginning installation.

PACKAGE CONTENTS

Before beginning installation of this product, make sure all parts are present. Compare parts with package contents list and diagram as below. If any part is missing or damaged, do not attempt to assemble, install or operate this product.

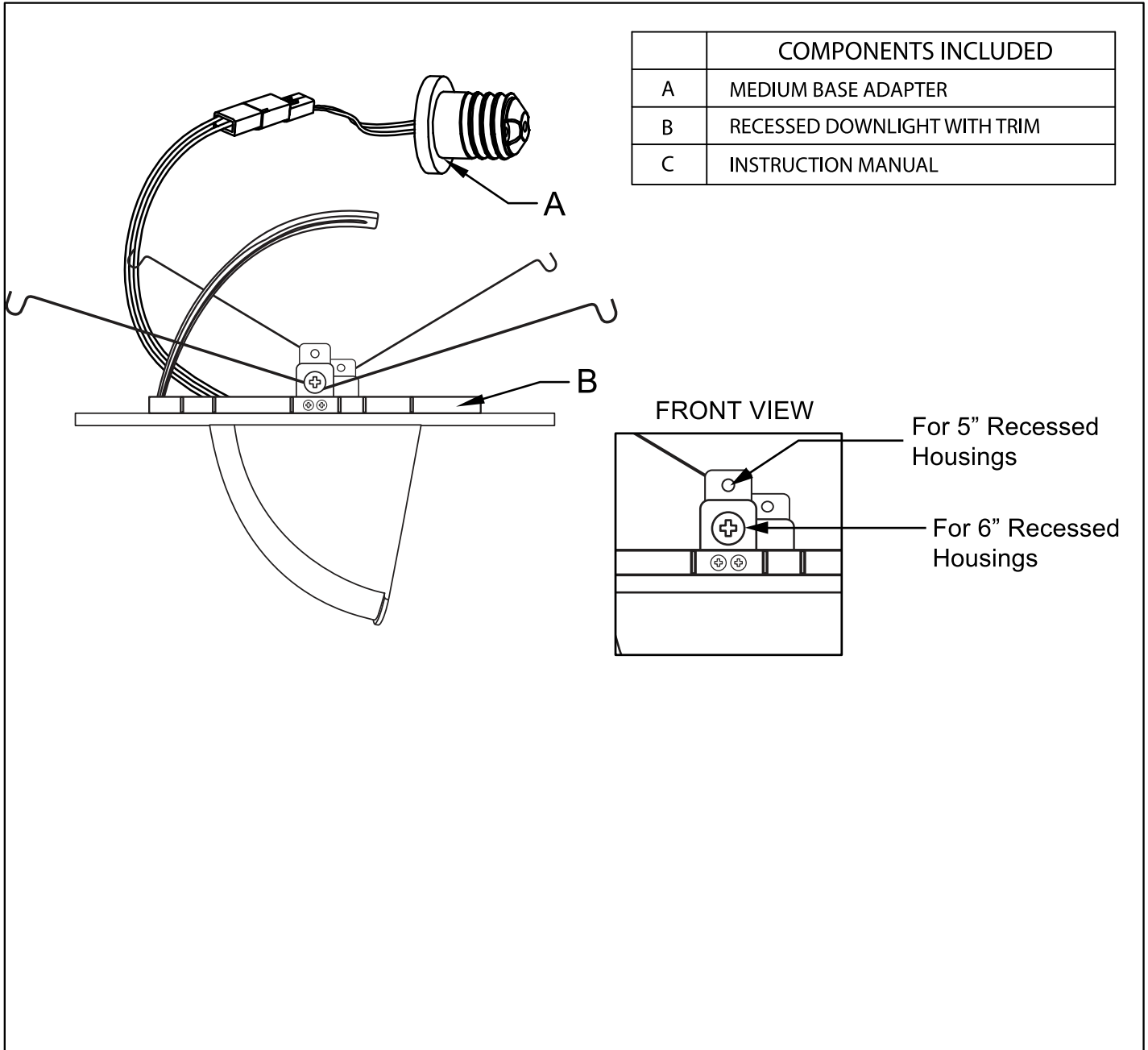

1. Installation into Existing Recessed Incandescent Fixture: For use with 5" OR 6" recessed housings (housing sold separately)

LED recessed trim will fit into select existing 5" or 6" nominal incandescent housings.

- Step 1. Turn OFF power at switch and fusebox or circuit breaker.
- Step 2. Remove existing trim installed in recessed housing (if necessary).
- Step 3. If applicable, slide lampholder bracket to its upward maximum position. If the lampholder bracket is less than 4.5 inches from the bottom edge of the fixture enclosure, the lampholder bracket must be removed.
- Step 4. If necessary, remove the lampholder mounting bracket by removing wing nut (see FIG. 2) and the lampholder from the bracket (see FIG. 2), then attach the provided label to the existing luminaire.
- Step 5. Install adapter into socket (see FIG. 3).

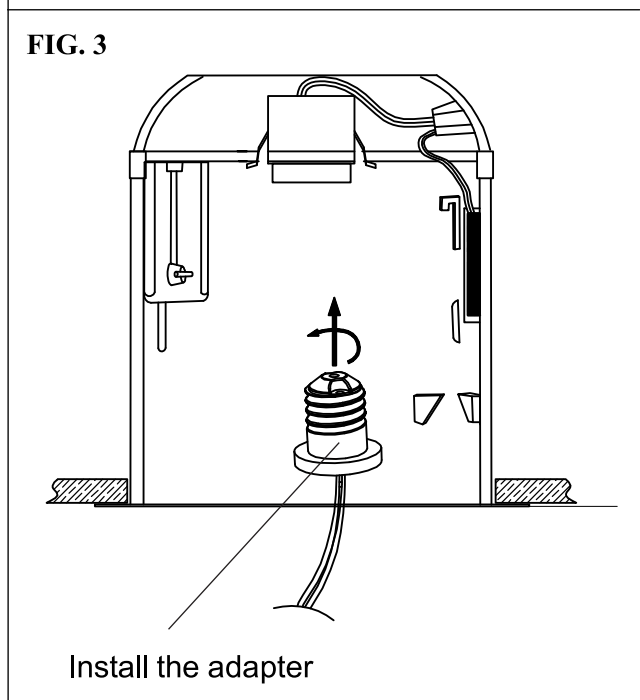
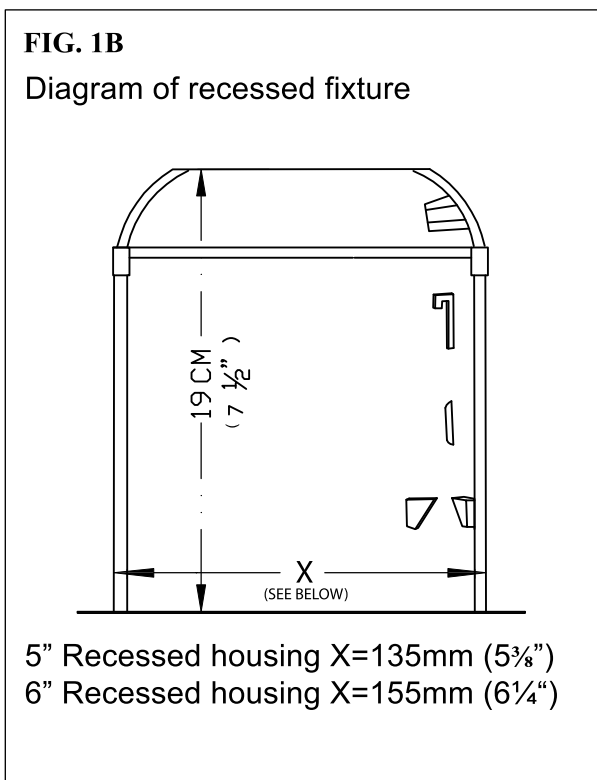
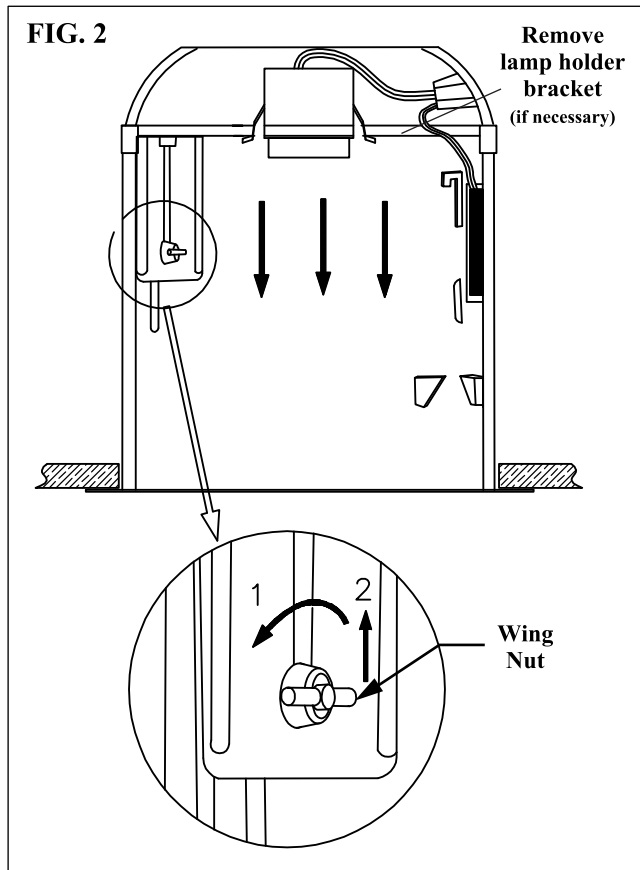
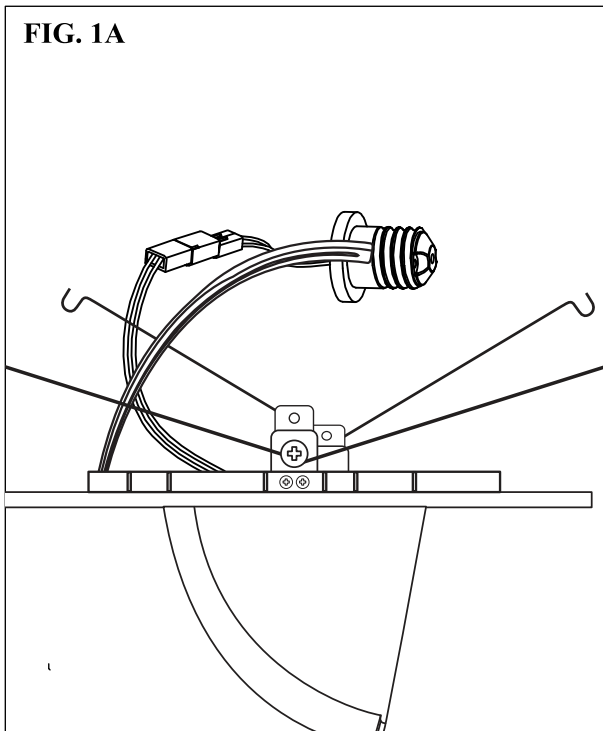

Step 6. Connect the orange connectors together (see FIG. 4B).

Step 7. Insert torsion springs into fixture housing brackets (see FIG. 5).

Step 8. When installing trim into a 5" recessed housing, the torsion spring must be moved. Unscrew the torsion spring from the 6" position and move to the 5" position as shown.

Step 9. Gently push up trim and torsion springs so they begin to expand and lift trim in place (see FIG. 6).

FIG. 4A

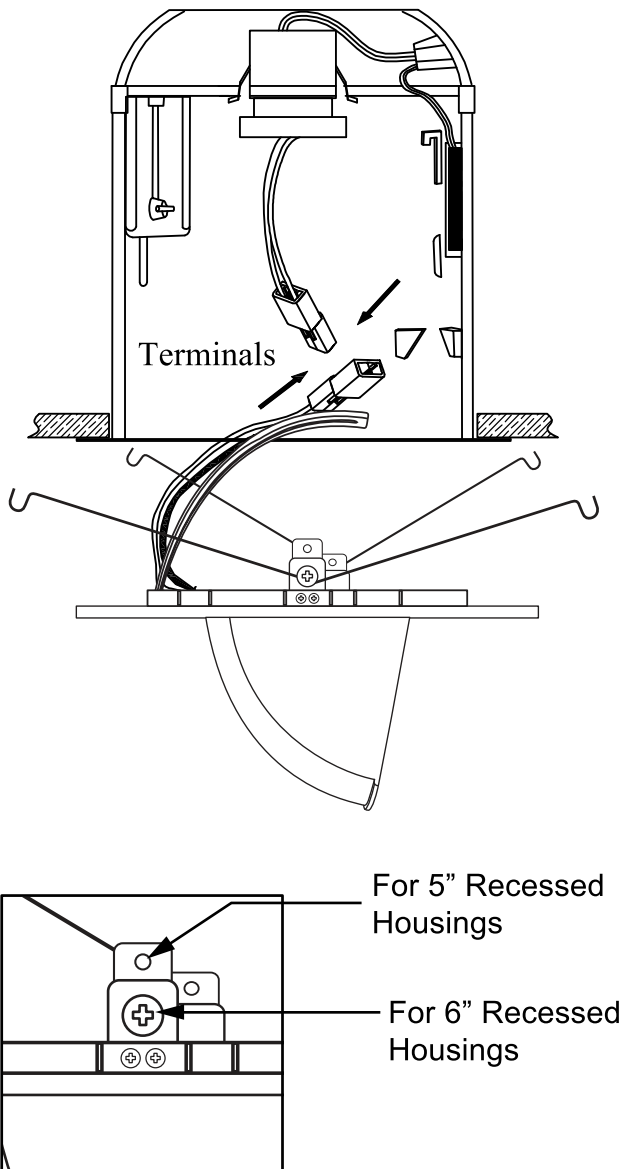

FIG. 5

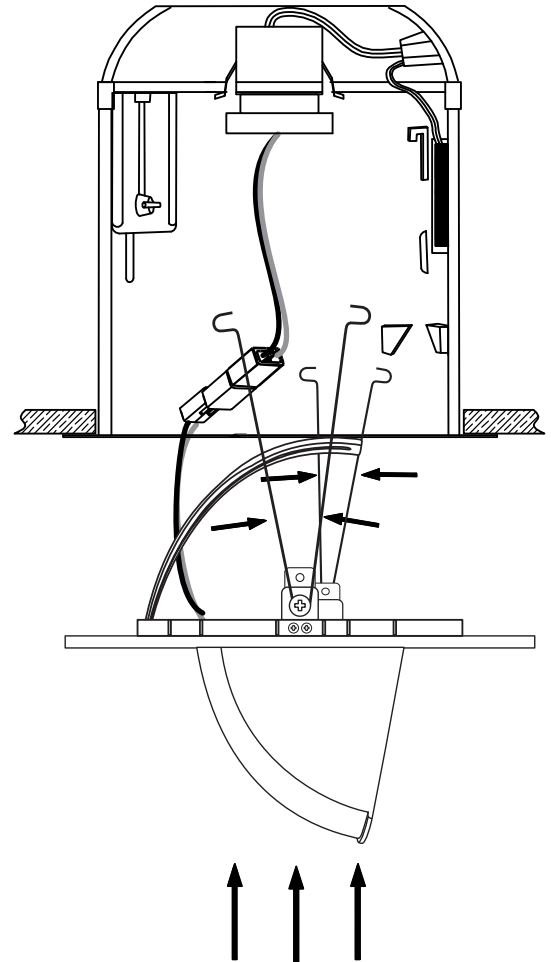
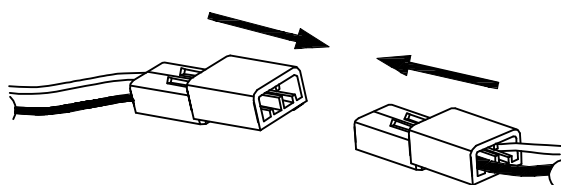
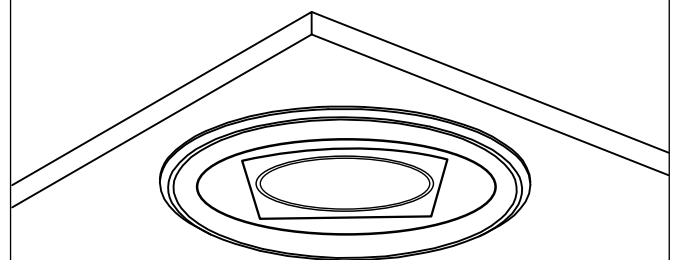

FIG. 4B



Connect the Orange Connectors

FIG. 6



2. Installation into Existing Recessed LED Fixture with compatible Orange Connectors

LED recessed trim will fit into select existing nominal LED housings.

Step 1. Turn OFF power at switch and fusebox or circuit breaker.

Step 2. Remove existing trim installed in recessed housing (if necessary).

Step 3. Discard medium base adapter

Step 4. Connect the orange connectors together (see FIG. 2B).

Step 5. Insert torsion springs into fixture brackets (see FIG. 2A).

Step 6. Gently push up trim and torsion springs so they begin to expand and lift trim in place (see FIG. 3).

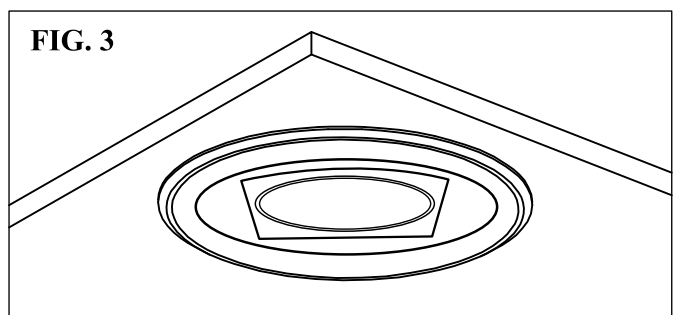
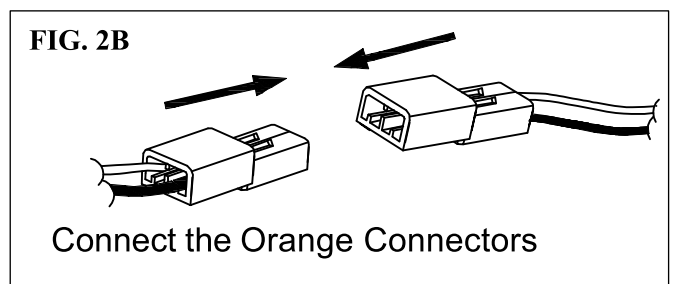
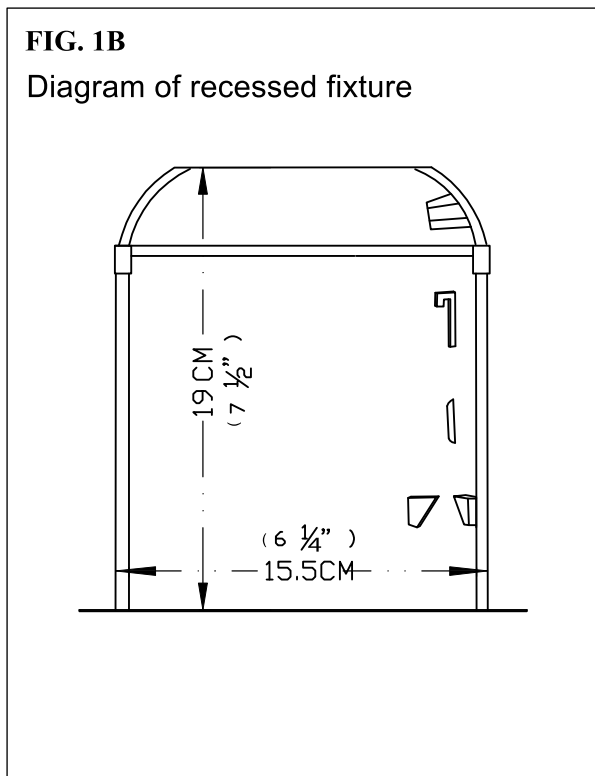
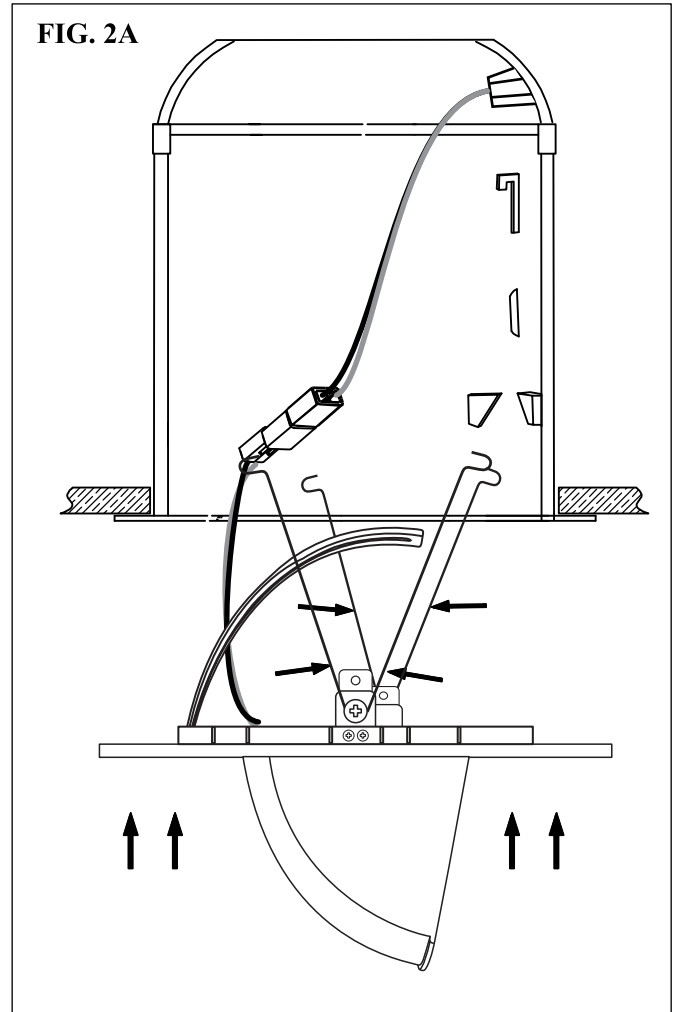
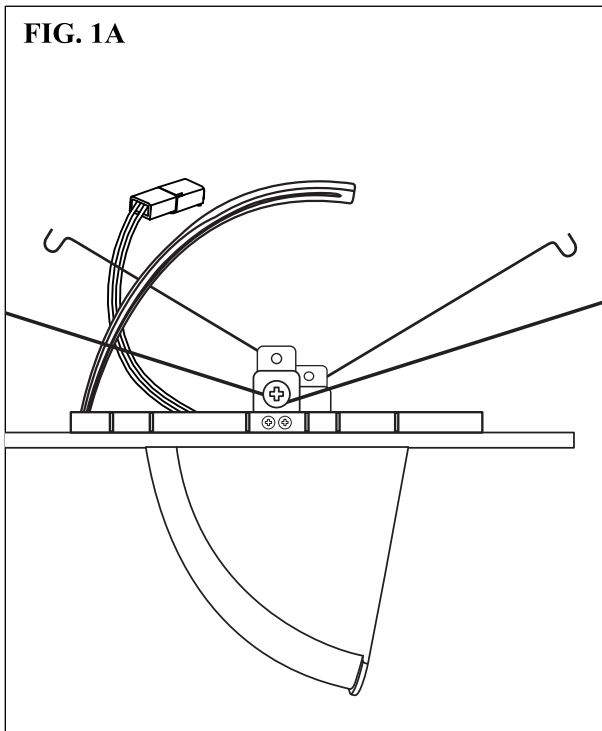

WARNING – Risk of fire or electric shock. LED Recessed Downlight with Trim installation requires knowledge of luminaires electrical systems. If not qualified, do not attempt installation. Contact a qualified electrician.

WARNING – Risk of fire or electric shock. Install this product only in the luminaires that have the construction features and dimensions shown in the photographs and/or drawings.

Do not make or alter any open holes in an enclosure of wiring or electrical components during installation.

WARNING – To prevent wiring damage or abrasion, do not expose wiring to edges of sheet metal or other sharp objects.

MIN. LAMP COMPARTMENT DIMENSIONS 135mm (5³/₈ in) DIA X 190mm (7¹/₂ in) HEIGHT When use in 5 inch recessed luminaire

MIN. LAMP COMPARTMENT DIMENSIONS 154mm (6 in) DIA X 188mm (7¹/₂ in) HEIGHT When use in 6 inch recessed luminaire

PRODUCT ELECTRIC RATING

INPUT VOLTAGE / FREQUENCY 120V/60Hz	INPUT CURRENT XXXmA	INPUT POWER 11.3 W
---	---	--

THE RECESSED DOWNLIGHT WITH TRIM IS ACCEPTED AS A COMPONENT OF A LUMINAIRE WHERE THE SUITABILITY OF THE COMBINATION SHALL BE DETERMINED BY CSA OR AUTHORITIES HAVING JURISDICTION.

