

SPEAKMAN COMPANY

SE-4300 Installation, Maintenance & Operation Instructions

GRAVITYFLO® PORTABLE EYEWASH

DESCRIPTION

Portable gravity fed eyewash for wall mounting or table top applications. Unit supplied with 20 gallon eyewash tank with spray heads, pull strap, wall bracket, and (1) 8oz bottle of (SE-4210) water preservative.

SPECIFICATIONS

TANK: 20 Gallon, Speakman Blue, High Density Polyethylene.
SPRAY HEADS: (2) Black, Molded Polypropylene.
ACTIVATOR (Pull Strap): Yellow, Thermoplastic Elastomer.
WALL MOUNTING BRACKET: 11 Gauge Steel with Black Powder Coat Finish.
FILL CAP: Black, High Density Polyethylene.
SIDE OUTLET: Integral 3/4" GHT for Draining Tank & Connecting the SE-4920 Drench Hose Option.
DRAIN: Integral 3/4" GHT Fitting.
WATER PRESERVATIVE: (1) 2oz. Bottle of SE-4210 Water Preservative.
EMERGENCY SIGN: Integral Eyewash Sign.
COMPLIANCE: Unit meets or exceeds the eyewash requirements as listed in ANSI Z358.1.
SHIPPING WEIGHT: 18 lbs.
OPERATION (FILLED) WEIGHT: 185 lbs

OPTIONS

◇ SE-4920 (Hand-Held Drench Hose)

INSTALLATION

The following is step by step instructions of how to install the SE-4300 unit. Before getting starting, review the rough-in drawing on the backside of this sheet to help assure proper understanding and installation. The eyewash unit weights approximately 185 lbs. when completely filled. So be sure to select a mounting structure (wall, etc.) and mounting hardware that is suitable to hold a vertical load of minimum 300 lbs. **1)** Determine desired location of the eyewash. This location should be *suitable so the unit does not freeze, or become overheated.* **2)** Determine the desired height of the eyewash spray heads, which need to be between 33"-45" to comply with the ANSI standard, and then use the dimensions given in the rough-in diagram to determine the required mounting height of the wall bracket. Make sure the bracket is as level as possible to ensure proper flow pattern, and mount the bracket using the appropriate hardware. **3)** Place empty tank on bracket by latching first, the upper handle portion of eyewash tank to upper "hook" of wall bracket, and position the bottom portion of tank onto the wall bracket so drain fitting can be inserted through drain hole of tank and hole in wall bracket simultaneously. Lock the drain fitting into place by assembling washer & nut to underside of drain fitting. **4)** Make sure yellow plastic elastomer activation strap is completely pushed onto the (2) spray heads. Remove fill cap from top of tank, and empty the 8 oz bottle SE-4210 water preservative into the tank. Continue to fill the tank with potable water (approximately 20 gallons). Failure to use potable water can result in emergency units producing impure or contaminated water causing possible further injury. **5)** Assemble fill cap to tank, and secure with tamper-evident seal tie.

OPERATION

The eyewash is activated by pulling the Yellow elastomer strap from the spray heads. Allow the unit to run until water level is below spray heads, and water no longer is coming from spray heads. **IMPORTANT**, the unit should be full at all times, to achieve the minimum 15 minute run time as stated by ANSI, in an emergency situation. Refill the tank to a full level after each activation. Note: before refilling tank dry & clean outside of spray heads, and inside of pull strap to remove debris, and to assure proper sealing.

TESTING PROGRAM

The ANSI standard states that "*self-contained eyewash units shall be visually checked to determine if the flushing fluid needs to be changed or supplemented*". It is recommended that a visual inspection be conducted weekly, unless this product is placed in environments with extreme conditions that may affect the form, fit, or function of the product (temperature, dirt, etc.). If this is the case then the inspection should be conducted more often as the end-user deems necessary. Speakman Company furnishes a testing record tag (91-0635) with each unit. On this tag the date of inspection and the inspector's initials should be noted.

MAINTENANCE

This product should not require much maintenance, other than the occasional cleaning & disinfection, which will depend on the environment of the unit. Recommendation for thorough cleaning & disinfecting consists of **1)** add 1/2 cup (4 fluid oz) of Clorox (liquid bleach) to a full tank of potable water, and allowing it to sit for 15 minutes. **2)** Then drain mixture, and rinse thoroughly several times with potable water. For further information on Clorox, call toll-free at 1-800-292-2200. **3)** Refill tank to put back in to service.

WARNING: Should any repair part be required, use only genuine Speakman parts for repair or replacement. See available replacement parts listing below, to order parts call 1-800-537-2107.

ROUGH-IN

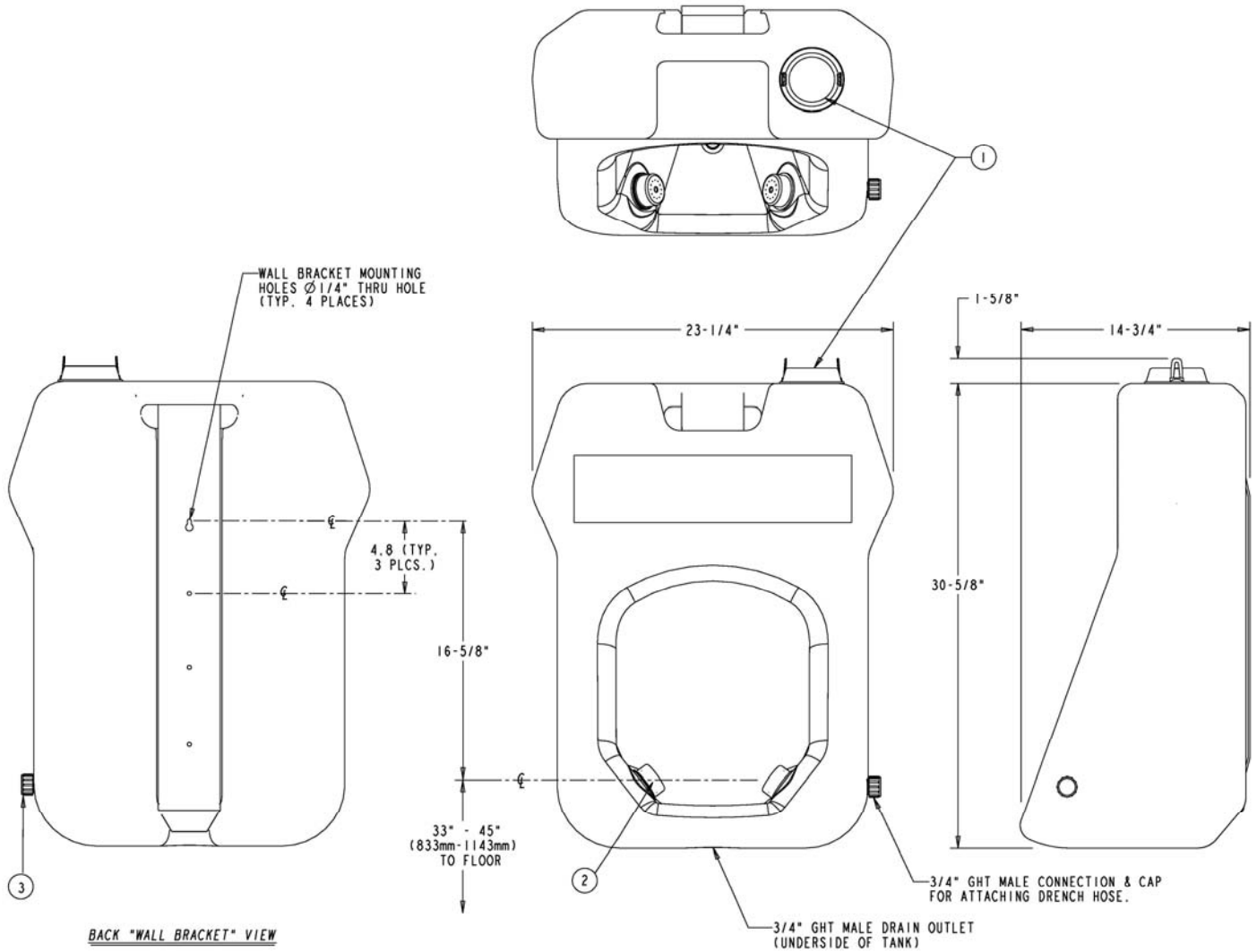

SE-4300 REPLACEMENT/REPAIR PARTS

<u>ITEM</u>	<u>PART/GROUP #</u>	<u>DESCRIPTION</u>
1	RPG07-0117	Fill Cap
2	RPG38-0297	(2) Spray Head Assemblies
3	RPG07-0096	Side Outlet Cap
N/S	RPG56-0171	Pull Strap Activator
N/S	RPG05-2434	(6) 12" Tamper-Evident Seal Tie

FLOW DATA

EYEWASH:

RUN TIME	15 Minutes (Minimum)
FLOW RATE GPM (LPM)	.4 (1.5) (Minimum)

SPEAKMAN®

PO Box 191 Wilmington, DE 19899

Phone: 800-537-2107 Fax: 800-977-2747

Visit us on the web at www.speakmancompany.com