

ULTRA PRO™ SERIES FAN / LIGHT MODEL RB110L1

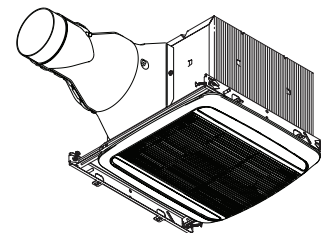

Quick Installation and Quiet Operation

FEATURES

UltraQuick™ Installation Technology

- Unique telescoping mounting frame fits through retrofit drywall opening to allow easy installation from the room side. No attic access needed!
- Captive mounting frame screws allow for easy new construction installation
- Mounting frame positioning tabs provide easy vertical positioning for new construction
- Works with any type of joist or truss system
- Duct connector and electrical knockout plate mount to outside or inside of housing, providing flexibility for new construction and retrofit applications
- Easy to insert and remove snap-in housing and blower

QStream™ Sound Technology

- Airflow-smoothing baffles reduce turbulence

QFlow™ Damper Technology

- When fan is on, damper position in the airstream is minimized to reduce static pressure and noise
- When fan is off, damper provides a tight seal to prevent back drafts

UltraLucent™ Lighting Technology

LIGHTING / GRILLE:

- Highly efficient, 18 Watt, integrated LED, dimmable
- LED lasts up to 25,000 hours
- Unique, low profile design for wide light pattern
- Even lens diffusion eliminates hotspots

TO OPERATE FAN AND LIGHT:

- Use only an ON/OFF or timer switch to operate the fan.
- Use only an ON/OFF switch, timer switch or relay-switch to operate the LED light.
- The LED light can be used with some dimmable switches.
- Both the fan and LED light can be put on one switch.

DIMMING CONTROLS:

- May not be compatible with all dimmer controls
 - Each application is unique and various factors such as load, common neutrals or other electrical products on the circuit can, in certain instances, cause variance in system performance.
 - Dimmer model numbers vary slightly depending on color, packaging type, etc. such that variations of Model numbers may be suitable. Consult dimming system manufacturer for additional support in operation
- * For a list of compatible controls, see broan.com.

Blower

- Plug-in, permanently lubricated motor, engineered for continuous use

Housing

- Height allows for installation in 2" x 8" (nominal) construction

Grille

- Polymeric construction, innovative design

U.L. Listed for use over bathtubs and showers when connected to a GFCI-protected branch circuit (ceiling mount only)

Use an ON/OFF switch, timer, or speed control to operate this ventilator. Use of speed control other than the Broan 78V and 78W may cause a motor humming noise.

3 Year Warranty



JA8-2019

Broan-NuTone LLC, 926 West State Street, Hartford, Wisconsin, USA 53027 Broan-NuTone.com 800-558-1711
Venmar Ventilation ULC, 550 Lemire Blvd., Drummondville, Québec, Canada J2C 7W9 Broan-NuTone.ca 800-567-3855

REFERENCE	QTY.	REMARKS	Project
			Location
			Architect
			Engineer
			Contractor
			Submitted by Date



PERFORMANCE SPECIFICATIONS ULTRA PRO™ SERIES FAN / LIGHTS

HVI PERFORMANCE

Model	0.1 Ps - Static Pressure (inH2O)				0.25 Ps
	Airflow (CFM)	Sound (Sones)	Power (Watts)	Efficacy (CFM/Watt)	Airflow (CFM)
RB110L1	110	0.8	32.4	3.3	90



HVI-2100 CERTIFIED RATINGS comply with new testing technologies and procedures prescribed by the Home Ventilating Institute, for off-the-shelf products, as they are available to consumers. Product performance is rated at 0.1 in. static pressure, based on tests conducted in a state-of-the-art test laboratory. Sones are a measure of humanly-perceived loudness, based on laboratory measurements.

ELECTRICAL & WEIGHT

Model	Volts	Hz	Amps*	Shipping Weight (lbs.)
RB110L1	120	60	0.5	13.6

* Total connected load



JA8-2019

DIMENSIONS (Inches)

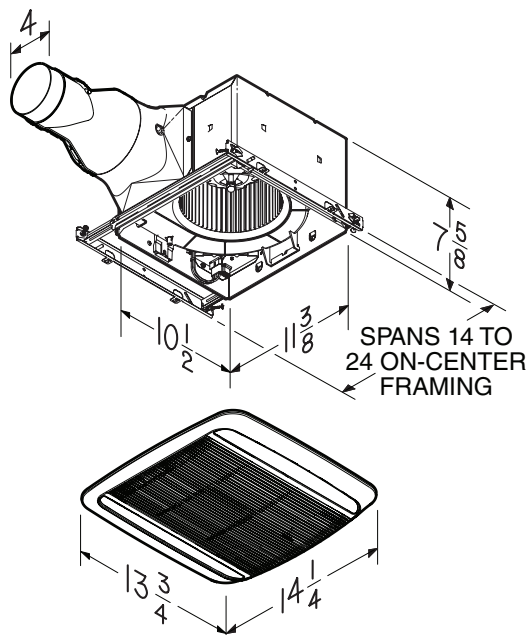

Model RB110L1

