



Project Name: _____

Location: _____

Item #: _____ Qty: _____

Model: _____

NARROW DEPTH REACH-IN REFRIGERATORS AND FREEZERS

MODEL: USRF-1D/19 USFZ-1D/19



USRF-1D/19



USFZ-1D/19

U-Star's Solid Door Narrow Depth Reach-In Refrigerators and Freezers are constructed of heavy duty stainless steel making them strong and durable enough to survive any kitchen environment. Their narrower design is great for tight areas where space is limited. The cooling units are bottom mounted and slide out for easy maintenance and cleaning. All models come with 6" casters and plastic coated wire shelving that is easily removable to adjust the shelf height. The front digital controllers and LED readout makes it easy to adjust the interior temperature. These models are ETL Listed and ETL Sanitation. They are backed with a 2 year warranty on parts and labor and a 5 year warranty on the compressor.

FEATURES AND CONSTRUCTION

- 430 series stainless steel exterior
- Painted aluminum interior
- Environmentally-friendly R290 refrigerant
- Self-closing doors
- Precise digital temperature controller with LED display
- Foamed-in-place polyurethane high density cell insulation throughout the entire cabinet
- Bottom-mounted cooling unit that slides out
- Removable door gasket
- Recessed door handles
- (4) 6" casters (2 locking and 2 non-locking)

ELECTRIC

115V / 60Hz / 1Ph
7' (2.1m) NEMA 5-15P cord set included

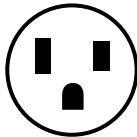

NEMA 5-15P

3RD PARTY APPROVALS



Intertek



Intertek

NOMINAL STORAGE CAPACITY

USRF-1D/19 15.6 Cu Ft (538 L)

USFZ-1D/19..... 15.6 Cu Ft (538 L)

TEMPERATURE

USRF-1D/19 32°F to 41°F (0°C to 5°C)

USFZ-1D/19..... -7°F to 0°F (-22°C to -18°C)

- These models are designed to operate in an environment where temperature and humidity do not exceed 75°F (24°C) and 55% relative humidity

U-STAR WARRANTY

U-Star reach-in refrigerators and freezers are warrantied for 2 years on parts & labor, 5 year warranty on the compressor.

For warranty service on these products please call National Service America (NSA) at 1-877-672-7740.

Plan Views

USRF-1D/19

USFZ-1D/19

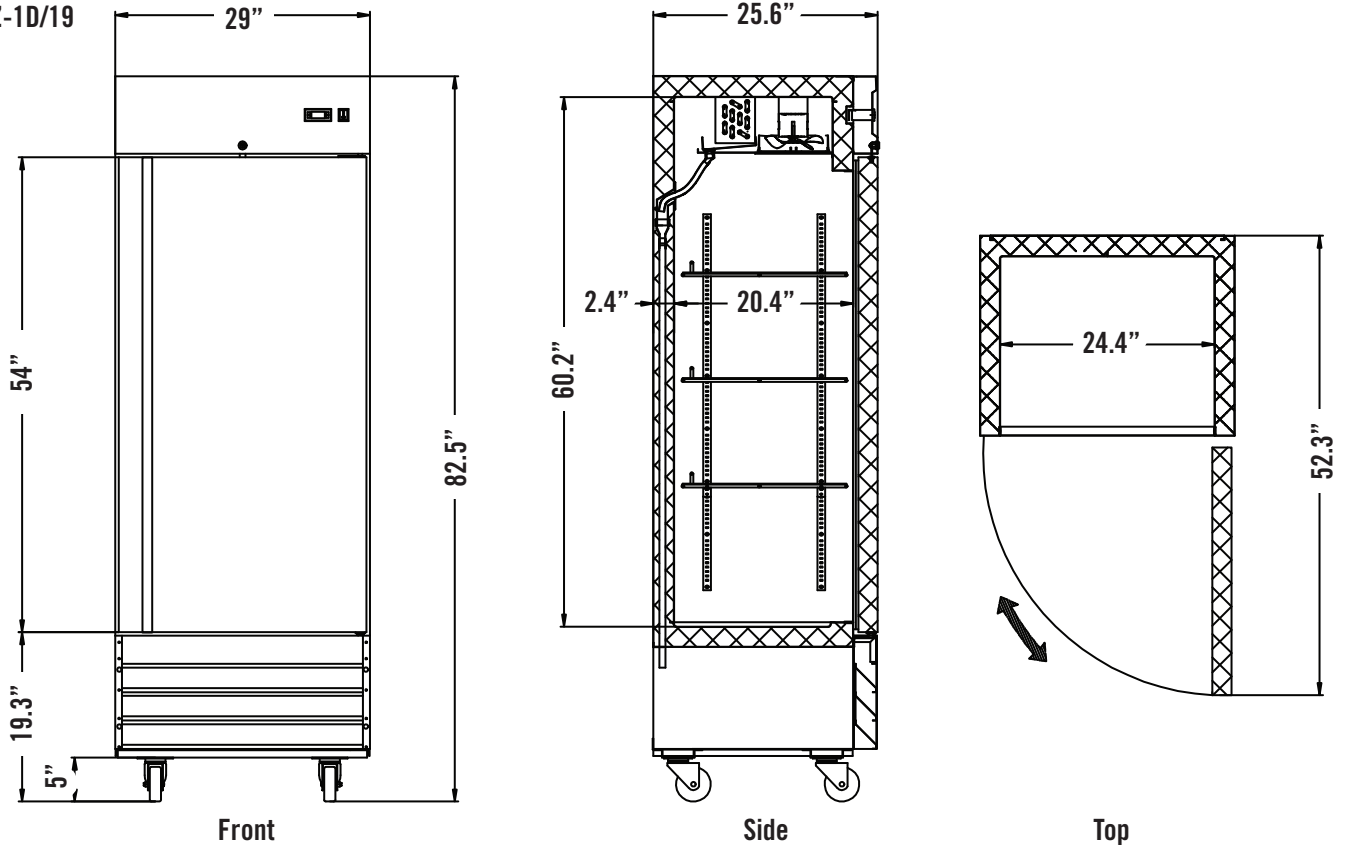

Model	USRF-1D/19	USFZ-1D/19
Type	Refrigerator	Freezer
Doors	1	1
Shelves	3	3
Net Volume (Cu. Ft.)	15.6 Cu. Ft.	15.6 Cu. Ft.
Overall Dimensions (in)	29" × 25.6" × 82.5"	29" × 25.6" × 82.5"
Interior Dimensions (in)	24.4" × 20.4" × 51.6"	24.4" × 20.4" × 51.6"
Refrigerant	R290	R290
Horsepower	1/3	2/3
Voltage/Hertz/Phase	115/60/1	115/60/1
Amps	3.1	3.8
Net Weight (lbs)	247 lbs	258 lbs
Gross Weight (lbs)	269 lbs	280 lbs
Shipping Dimensions (in)	30.2" × 27.4" × 84.4"	30.2" × 27.4" × 84.4"