

For  System

Video Door Phone System

User Manual

LCC SYSTEM CONFIGURATION DIAGRAM

► LCC SYSTEM WITH TWO ENTRANCES

Indoor monitor built-in power supply

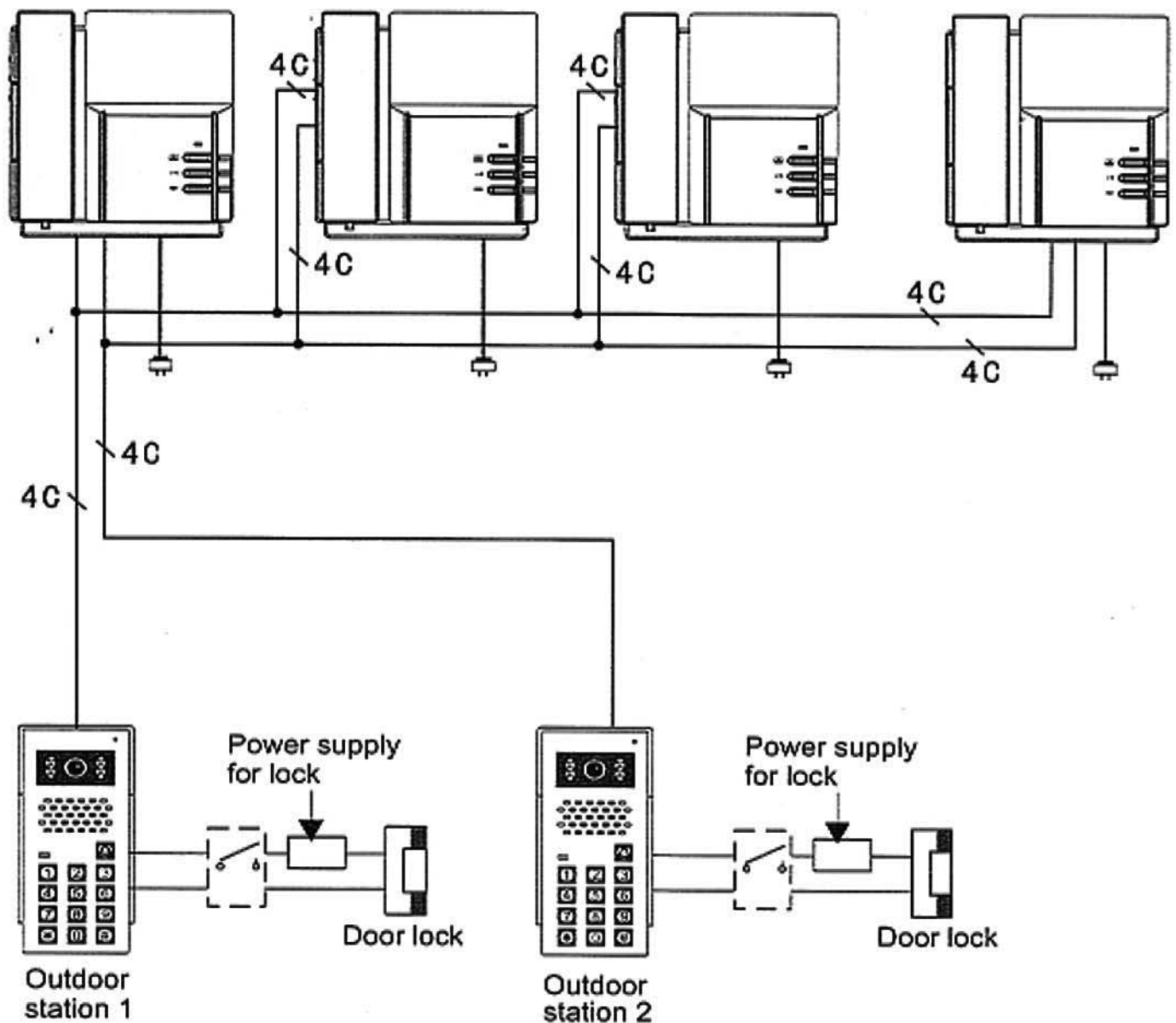

LCC SYSTEM CONFIGURATION DIAGRAM

► LCC SYSTEM WITH TWO ENTRANCES

Indoor monitor external power supply

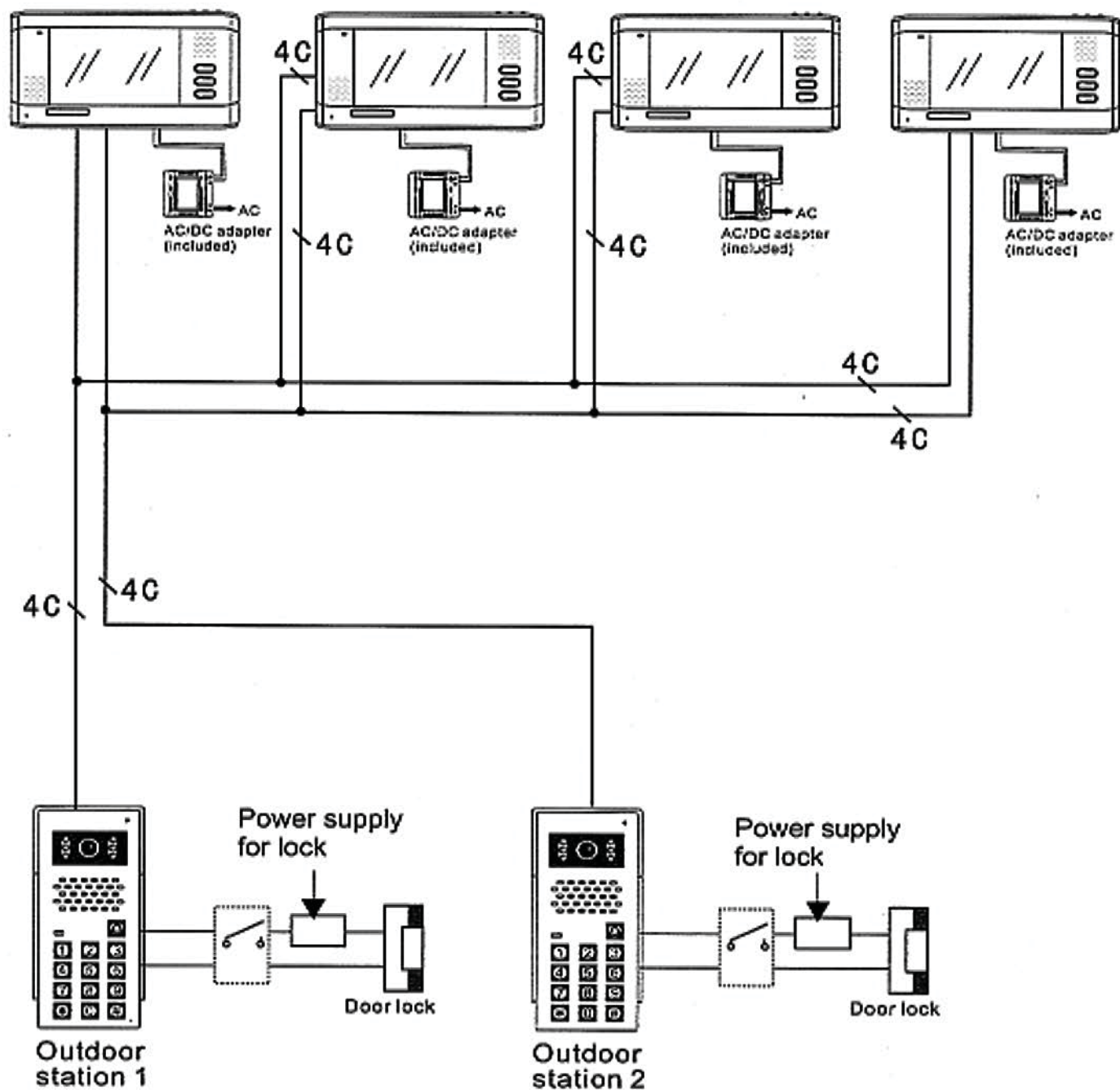

Specification



Power	DC 14.5V
Camera lens	1/3 CCD 72 degree ken
Illumination(minimum)	0.05 LUX
Communication duration	120s
Communication method	Duplex communication
Working temperature	-20°C ~ +55°C
IP rating	55

No.	Icon	Description	No.	Icon	Description
①		Monitor	⑥		Ringing volume
②		Door unlocked	⑦		Chroma/contrast
③		Talking	⑧		Calling
④		Talking volume	⑨		Hang off
⑤		Brightness			

CAUTION:

1. When the outdoor station can only call one apartment, and the apartment connects with more than one indoor monitor, please connect the J2 of the indoor monitor, which is furthest from the outdoor station. And pull out the J2 on the other indoor monitors.
2. When the outdoor station can only call one apartment, and the apartment connects with more than one indoor monitor, please connect the J1 and J3 of the indoor monitor, which is the closest from the outdoor station. And pull out the J1 and J3 on the other indoor monitors.
3. When the outdoor station can call more than two apartments (including two), please disconnect J3 of all the indoor monitors.

SYSTEM DIAGRAM

► Wiring connection

- | | | | |
|---------|---------|-----------|----------|
| 1. Red | 2. Blue | 3. Yellow | 4. White |
| 1-Audio | 2-GND | 3-V+ | 4-Video |

Indoor Monitor

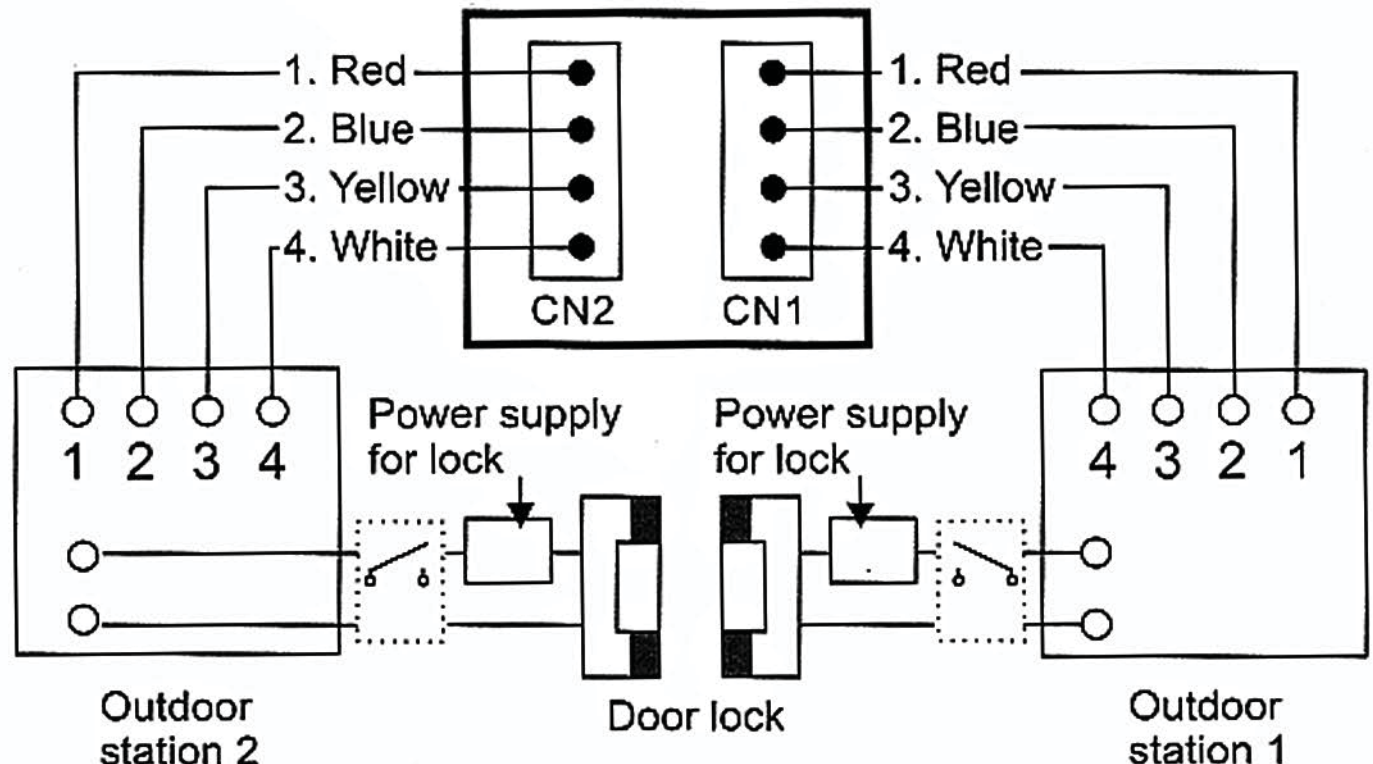

INSTRUCTION:

- Cables of LCC system:
 - Untwisted cable.
 - Wire $\geq 0.2\text{mm}^2$, from outdoor station to the farthest monitor distance $\leq 28\text{m}$.
Wire $\geq 0.3\text{mm}^2$, from outdoor station to the farthest monitor distance $\leq 50\text{m}$.
Wire $\geq 0.5\text{mm}^2$, from outdoor station to the farthest monitor distance $\leq 70\text{m}$.
- Maximum 4 indoor monitors and 2 outdoor stations for parallel connection.
- Handset indoor monitor with two function buttons and hands-free indoor monitor with three function buttons do not contain transferring or intercom functions.
- Every indoor monitor needs power: 14.5V, 1.3A (except build-in power supply).
- The distance between power supply to indoor monitor:
 - Wire $\geq 0.5\text{mm}^2$, the distance (black and white indoor monitor) $\leq 8\text{m}$.
 - Wire $\geq 0.5\text{mm}^2$, the distance (colour indoor monitor) $\leq 10\text{m}$.

OPERATION

▶ Visitor calls

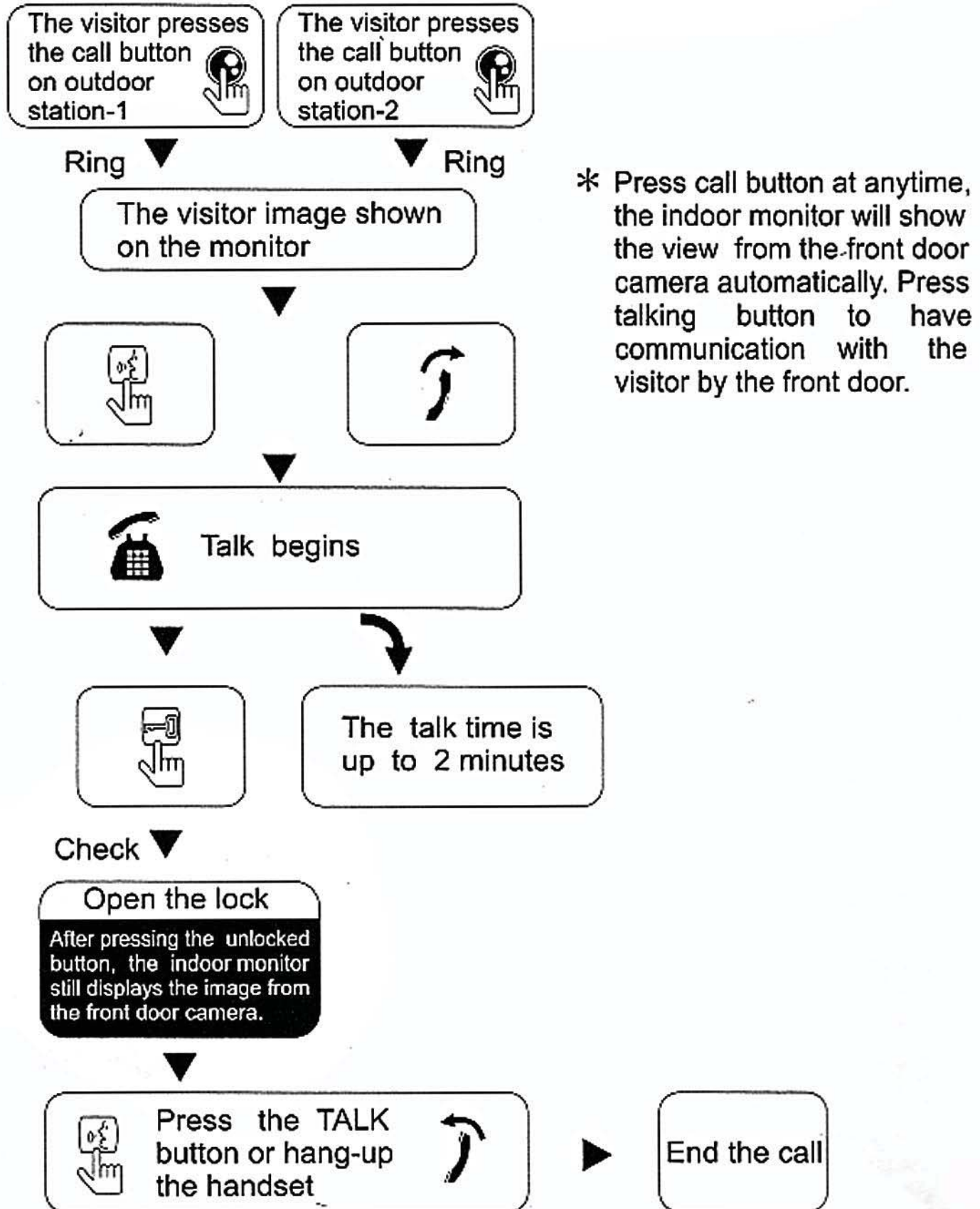

► MONITOR

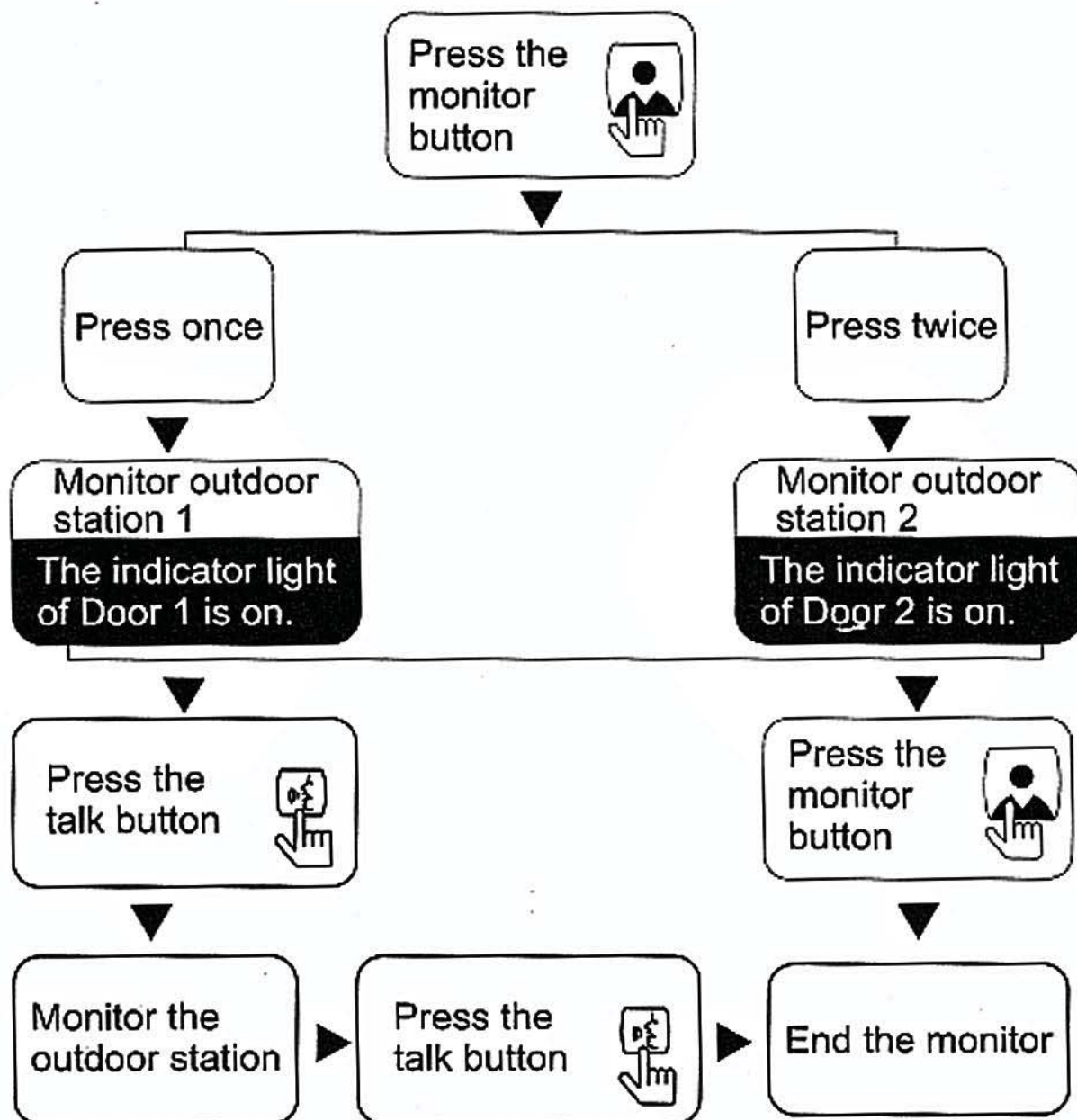

► Call transferring from main indoor monitor to extension indoor monitor (some models do not have such functions.)

During the conversation between the outdoor station and the indoor monitor, press  button on the main indoor monitor.

All indoor monitors ring

The indoor monitor press  button again to end the conversation.

Any indoor monitor press  button or pickup the handset to talk with the outdoor station.

► **Intercom** (some models do not have this function)

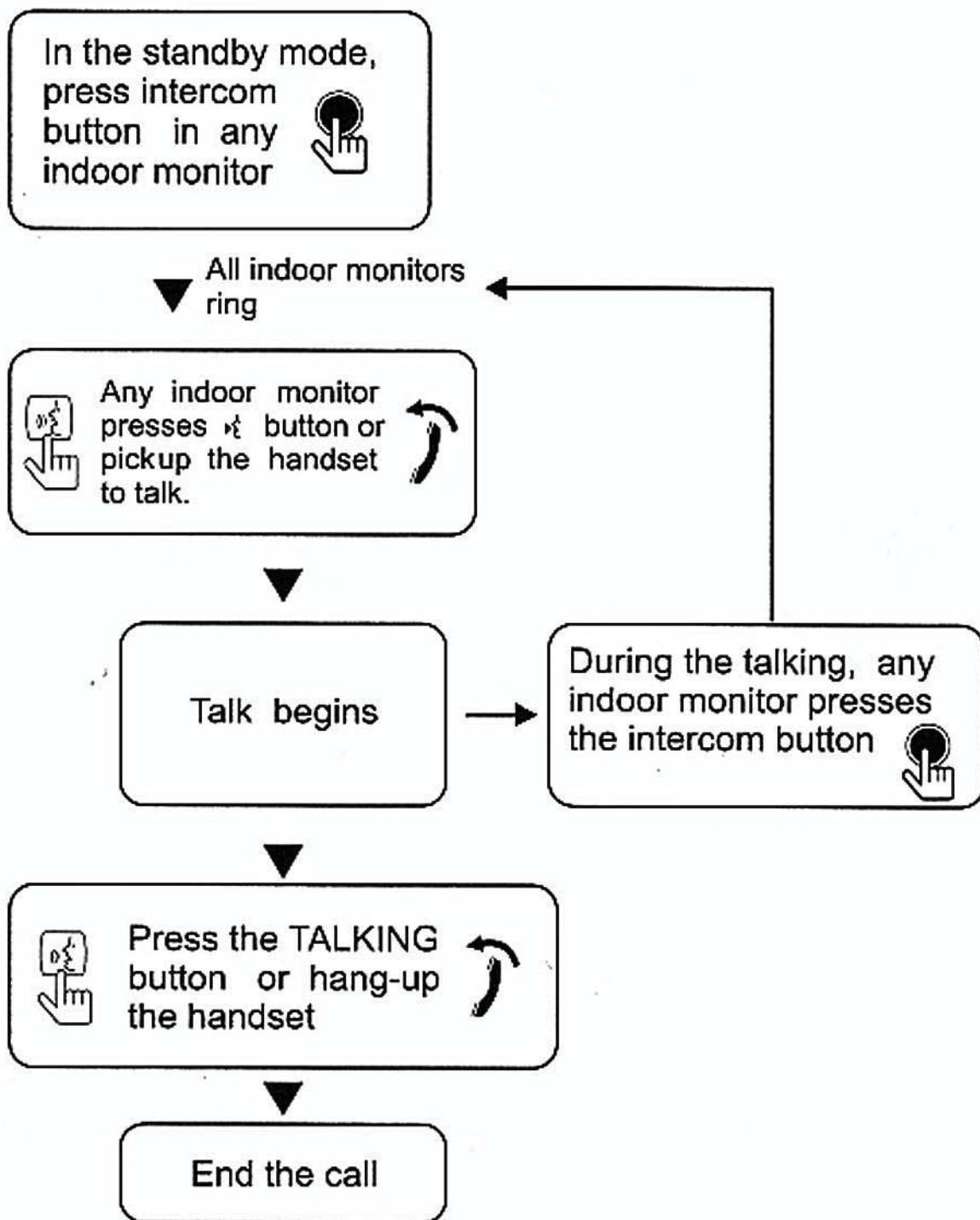

► **Password masking function**(some models do not have this function)

Some outdoor station can be connected with timer device (users purchase). When the timer device is activated and the line is connected, the passwords in the position 10-20 and 36-40 will be blocked. It means the passwords stop working.

Specifications of 50/561/562 series code access

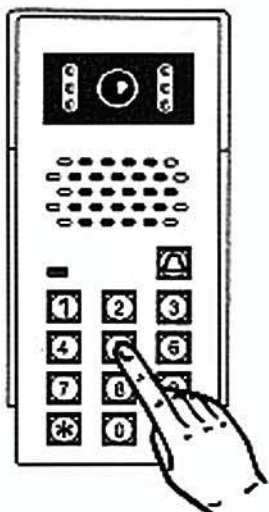

ATTENTION

1. The original factory defaulted programming password is 1234.
2. In the programming mode, set 40 groups of 4-digit passwords to unlock door.

Set programming code

1. Switch off the power, press * and hold, switch on the power. After hearing a long sound, release *.
2. After the long sound stops, another sound is heard, now you can enter the new 4-digit programming password.
3. After entering the new password, a "DI" sound can be heard for 5 times.

Enter to the programming mode

1. Press *, "DI" sound should be heard twice, and then enter 4-digit programming password, "DI" sound should be heard three times with LED light flashing. It indicates entering to the programming mode successfully.
2. Press * to exit the programming mode with "DI" sound in five times.

Set unlocked time

Factory default setting is 5 seconds.

1. Enter to the programming mode first.
2. Enter code 00, and "DI" sound should be heard twice.
3. Enter the targeted unlocked time: 2 digits (01 - 99 seconds); 00 is not valid in this mode.
4. After "DI" sound is heard for three times, it will return to programming mode.
5. Press * to exit the programming mode.

Add user passwords

1. Enter to the programming mode first.
2. Enter 01 - 40 (31 - 40 can not set unlocked time as they are normal open/closed).
3. Enter 4-digit password. If long "DI" sound is heard twice, it indicates password stored fails, and this password exists somewhere else. If "DI" sound is heard for three times, it indicates password stored succeeds. Return to the programming mode.

Delete user passwords

1. Enter to the programming mode first.
2. Enter 01 - 40.
3. Press # to delete the password stored in 01- 40.
4. After "DI" sound is heard for three times, return to the programming mode.

Delete user passwords directly

1. Enter to the programming mode first.
2. Press #. After "DI" sound is heard twice, then enter 4-digits password for deletion.
3. After "DI" sound is heard for three times, it indicates the password has been deleted and return to the programming mode.

Delete all settings

1. Enter to the programming mode first.
2. Press #. After "DI" sound is heard twice, press # again. Another "DI" sound is heard twice.
3. Then, press # for seven times, the system deletes all the setting. The unlocked time changes to 1 second, and the programming password does not change. After hearing "DI" sound for five times, the system reset, and all the user passwords are deleted.

Access control DH16B and DH11/12R

DH16B, DH11R and DH12R are access controls. They are used in the outdoor stations with with ID/IC card and fingerprint. They have wireless sensor for adding and deleting cards and fingerprint. The main parts are keypad DH16B and wireless sensor keypad DH11R/DH12R.

DH16B technical parameters	
Temperature: -20°C-+55°C	RH: ≤ 95%
Working current: ≤ 28mA	Application of card type: ID/IC card
Sensor time: ≤ 0.8S	Sensor distance: all around: ≤ 15cm
Capacity: ID card: 2000 PCS; IC card: 20000 PCS	



DH16B

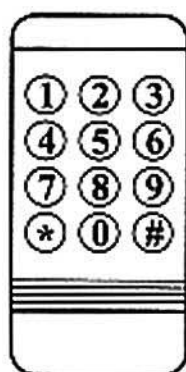

DH11R

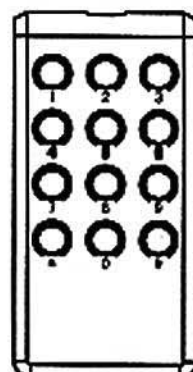

DH12R

DH11R sensor keypad technical parameters	
Silver zinc button batteries(2032): 3V	
Working current: ≤ 0.5mA	Sensor distance: all around: ≤ 20cm
Enter corresponded number to replace the relative ID/IC card	

DH12R sensor keypad technical parameters	
Use two No.7 LR03 AAA 1.5V alkaline batteries	
Working current: ≤ 0.5mA	Sensor distance: all around: ≤ 20cm
Enter corresponded number to replace the relative ID/IC card	

Operation(ID/IC card)

In the setting mode

Press * and #, enter XXXX(the administration password) and #. A Di sound indicates in the setting mode. Press * to return to standby mode. (No operation in 20 seconds will return automatically). The factory default password is 4567.

Modify access control password

In the setting mode:

Press 8 with a Di sound, then enter new 4-digits password (XXXX) and #. After a Di sound, re-enter the new 4-digit password and #. If two Di sounds is heard, it means the modification is successful. If enter different passwords twice, continued Di... sound will be heard, the modification of password fails. Please modify again.

Press * to return to standby mode.

If forget password, turn on the power again and press # for 3 seconds. If Bi is heard, default password is restored.

Set master card

In the setting mode:

Press 0, a Di sound heard, and press 7 to hear another Di sound. Then enter 6-digits master card number or swipe the master card. After a Di sound, the setting is completed.

Press * to return to setting mode, and press * again to return to standby mode.

----- Add user card -----

In the setting mode:

Press 1. Di sound indicates it is in the adding user card mode.

Enter the last 6-digits of a new card number. If Di sound is heard, it indicates the adding is successful. Or swipe the new card instead of adding the card numbers. If a Di sound and another Di sound are heard, it indicates the adding is successful.

Continuous batch adding new user cards is available. If a registered card is added, four Di Di Di Di rejection sounds will be heard. It indicates this card has been registered.

Press * to return to setting mode. Then press * to return to standby mode. No operation in 30 seconds will return automatically.

Use master card to add user card:

In the standby status, swipe master card once. A Di sound indicates it is in the adding card mode..

During the adding card mode, swipe each new card will accomplish with a Di sound. Another Di sound to confirm that the setting is successful. Registered card will be rejected. After four Di sounds, swipe master card again to return to standby mode.

----- Delete user card -----

In the setting mode:

Press 2 with a Di sound. It is in the delete card mode. Enter the last 6-digits of the deleted card. If a Di sound is heard, it indicates the deletion is successful. Or swipe the deleted card, if a Di sound is heard, and another Di sound indicates deletion is successful. Continuous batch deleting user cards is available. If deleted card is deleted again, the access control will sound four Di rejection sounds. It indicates this card has been deleted.

Press * to return to setting mode, and press * again to return to the standby mode. No operation in 30 seconds will return automatically.

----- Delete all user cards -----

In the setting mode:

Press 9 with a Di sound heard. And then press 9, two short Di sounds can be heard. After it stops, it indicates the deletion of all user cards is successful.

Press * to return to standby mode. No operation in 30 seconds will return automatically.

----- Set building number and machine number -----

In the setting mode:

Press 3, a Di sound is heard. Enter 6 digits (4-digits building No and 2-digits machine number), press # with a Di sound. It indicates the setting is successful.

Press * to return to standby mode. No operation in 30 seconds will return automatically.

----- Set the unlocking time -----

In the setting mode:

Press 4, a Di sound is heard, then enter 2 digits number from 01 to 99 as unlocking time. If a Di sound and another Di sound are heard, it indicates the unlocking time setting is successful.

Press * to return to standby mode. No operation in 30 seconds will return automatically.

== Operation of outdoor station with fingerprint ==

- ◆ Cooperate with remote control DH11R or DH12R.

----- Enter the setting mode -----

Input the admin default code twice (1234+1234), the yellow LED will be on. It is in the setting mode.

The default code is: 1234

----- Modify administrator code -----

In the setting mode:

Press * 3 (Yellow light blinks), and then enter a new administrator code(XXXX) twice. If Bi- is heard, it means the operation is successful.

Press # to exit the setting mode.

Notice: In case forget the admin code, power on first, then press # within 3 seconds. If Bi is heard, it means admin code is restored as default setting successfully.

----- Set the unlocking time -----

In the setting mode:

Press * 1 (Yellow light blinks), and then enter 2-digit number from 01 to 99 (Bi- is heard, and yellow light stops blinking). This 2-digit number is the unlocking time. For example, enter 05 means the unlocking time is 5 seconds.

Press # to exit the setting mode.

----- Add fingerprint -----

In the setting mode:

Press 000-899 (Yellow light blinks. If red light is on, it indicates the position is occupied. Press * twice to delete the information in this position and then add the fingerprint. If green light is on, it indicates the position is vacant. Fingerprint can be added.) + put the finger on the scanner until a Bi sound is heard. Then another Bi and Bi- will be heard. It indicates the addition is successful. If BiBiBi are heard, it indicates the addition fails. If BiBiBiBi are heard, it indicates the fingerprint exists.

Press # to exit the setting mode.

Notice: Maximum 900 fingerprints.

----- Delete the fingerprint -----

In the setting mode:

Delete one fingerprint: press 000-899, then press * twice to delete the fingerprint in 000-899. If light turns green means the deletion is successful.

Delete all fingerprint: press * 8 (Yellow light blinks), and then enter 8 twice (A continuous Bi - will be heard). The deletion is successful.

Press # to exit the setting mode.

----- Restore factory default -----

In the setting mode:

Press * 8 (Yellow light blinks), and then enter 9 twice (A continuous Bi - will be heard). The factory default is restored.

Press # to exit the setting mode.

Set security level

In the setting mode:

Press * 5 (Yellow light blinks), and then enter security level number twice (Parameter range is 1, 2, 3, 4, 5. The higher number indicates the higher accuracy of fingerprint recognition). If Bi- is heard, it indicates the setting is successful. If Bi Bi Bi are heard, it indicates the setting fails.

Press # to exit the setting mode.

Picture memory function

For the models with picture memory function

Automatic snapshot



In the calling status or in the monitoring status, the monitor screen will turn on automatically.

The outdoor station will capture one picture in the third second and store it automatically after the indoor monitor screen is on.

It only captures one picture automatically (Do not support automatic continuity snapshot).

Manual snapshot

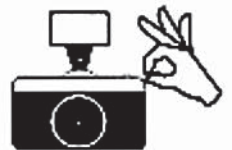

In the calling status or in the monitoring status, when the monitor screen displays image well, press  to capture a picture. The picture will be saved automatically.







NOTICE

Maximum storage: 400 pictures. After the number of pictures reaches 400, the oldest picture will be deleted automatically as long as a new picture is captured.



Check picture

Press  on the indoor monitor. Maximum six pictures in one screen to check. Press  or  to select a picture. Selected picture has yellow borders. Press  to zoom in the selected picture. Press  again to go back to previous page. The picture appears for 10 seconds. The checking mode will exit without any operation after 10 seconds. The indoor monitor will automatically return to the standby mode.



Delete picture

During checking picture mode, press  to delete the selected picture. In the monitoring status, press  and hold for 3 seconds to delete all the pictures.





Time calibration

Press  and hold for 3 seconds,

2011 - 01 - 01 00 : 00

Year- Month - Date Time

YEAR: the last two figures keep blinking, press  and  to adjust figures; Press  to confirm and the blinking moves to MONTH.

MONTH: figures keep blinking, press  and  to adjust figures; Press  to confirm and the blinking moves to DATE.

Referring to the above steps to adjust the DATE, HOUR and MINUTE. In 10 seconds without any operation, the time calibration will automatically exit and the indoor monitor will return to the standby state.