

# OUTDOOR

OD STONE 8 / OD SAT 5 / OD SUB 12

Installation Guide

Démarrage rapide / Quick Start

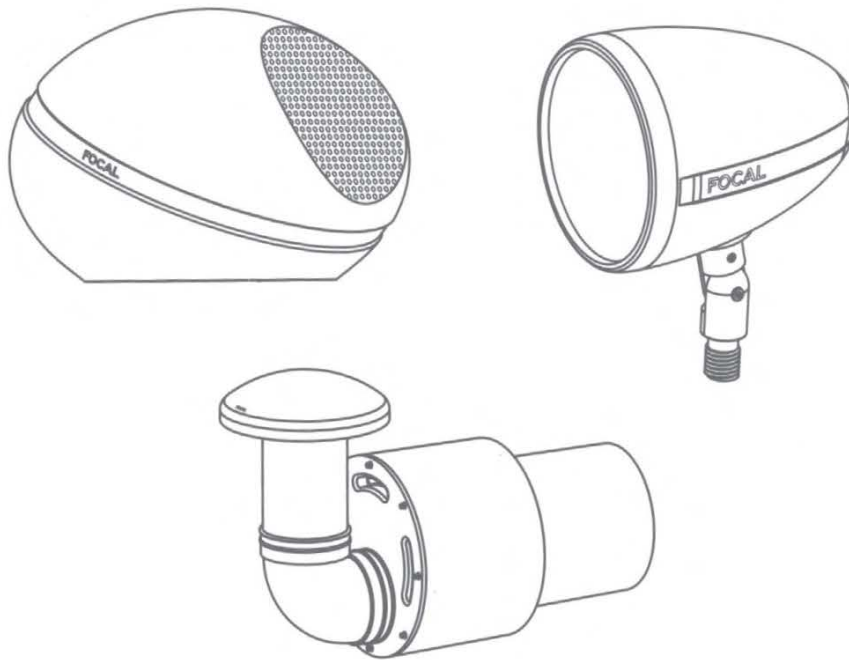

GO TO THE  
USER MANUAL



[https://www.focal.com/  
usermanual/outdoor](https://www.focal.com/usermanual/outdoor)

- FR Accédez à la notice d'utilisation
- DE Bedienungsanleitung lesen
- ES Acceda a las instrucciones de uso
- IT Accedi alle istruzioni per l'uso
- PT Ir para o manual do utilizador
- NL Ga naar de gebruiksaanwijzing
- PO Przejdź do instrukcji obsługi
- RU Перейти к инструкции по эксплуатации
- ZH 访问使用说明
- KO 사용설명서 보러가기
- JP 取扱説明書を見る
- AR اذهب إلى دليل الاستخدام

OD STONE 8

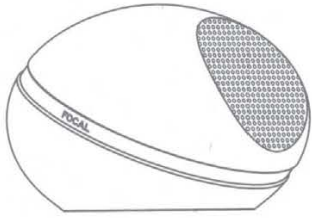

A  
x 1



B  
x 3



C  
x 1

OD SAT 5



A  
x 1



D  
x 2



E  
x 1



C  
x 1



F  
x 1

OD SUB 12

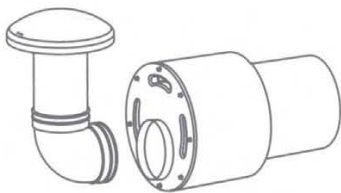

A  
x 1



B  
x 3



C  
x 1

OD STONE 8

8Ω

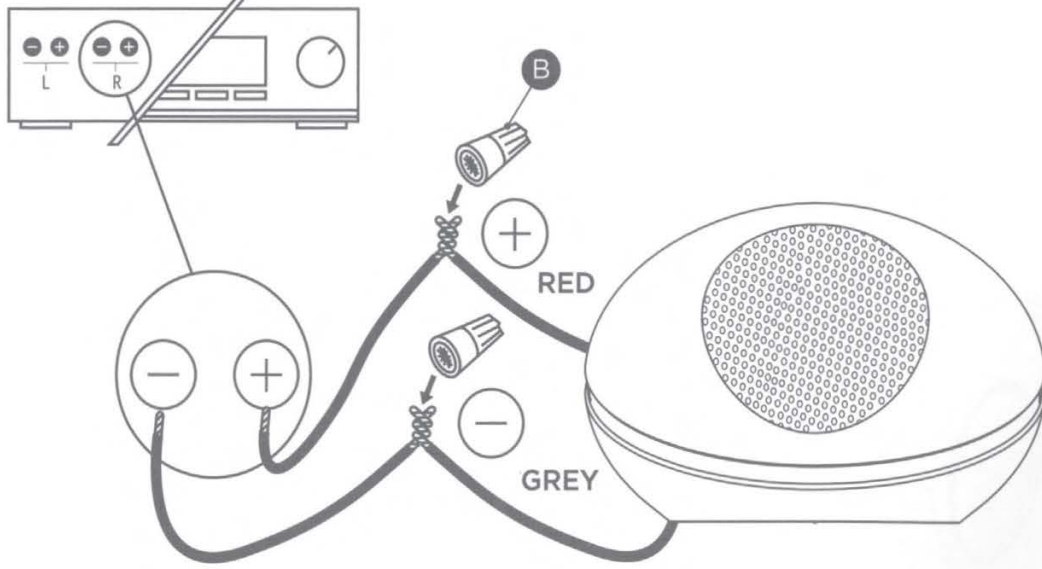

OD STONE 8

70/100V

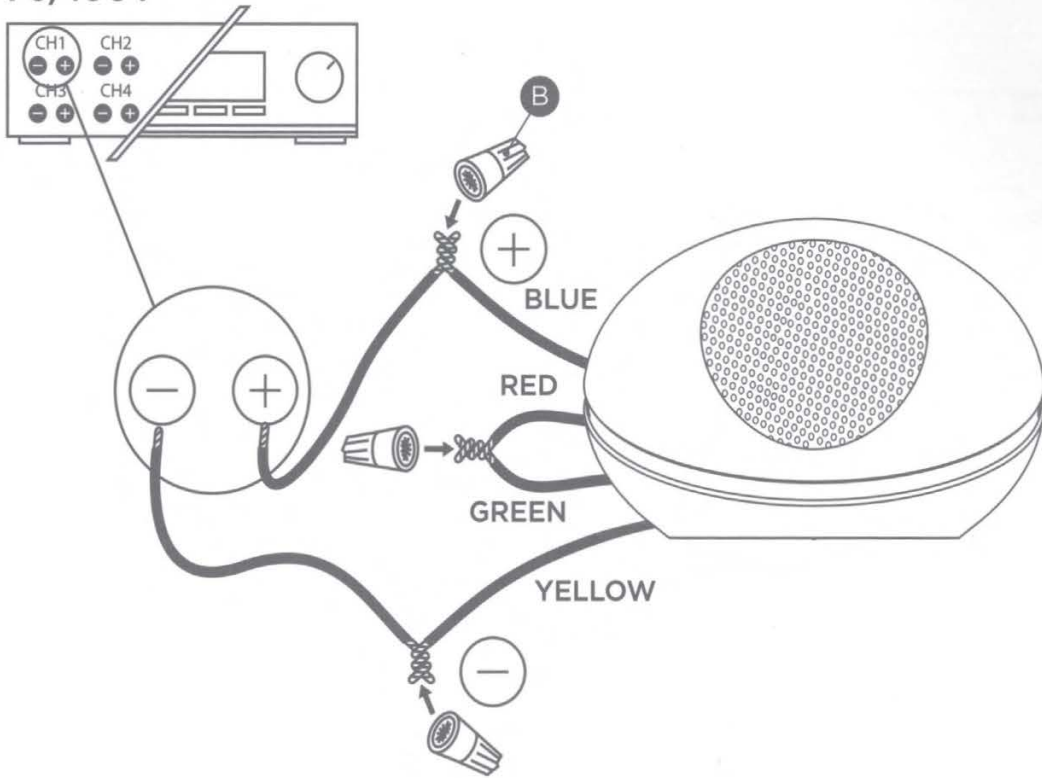

OD SAT 5

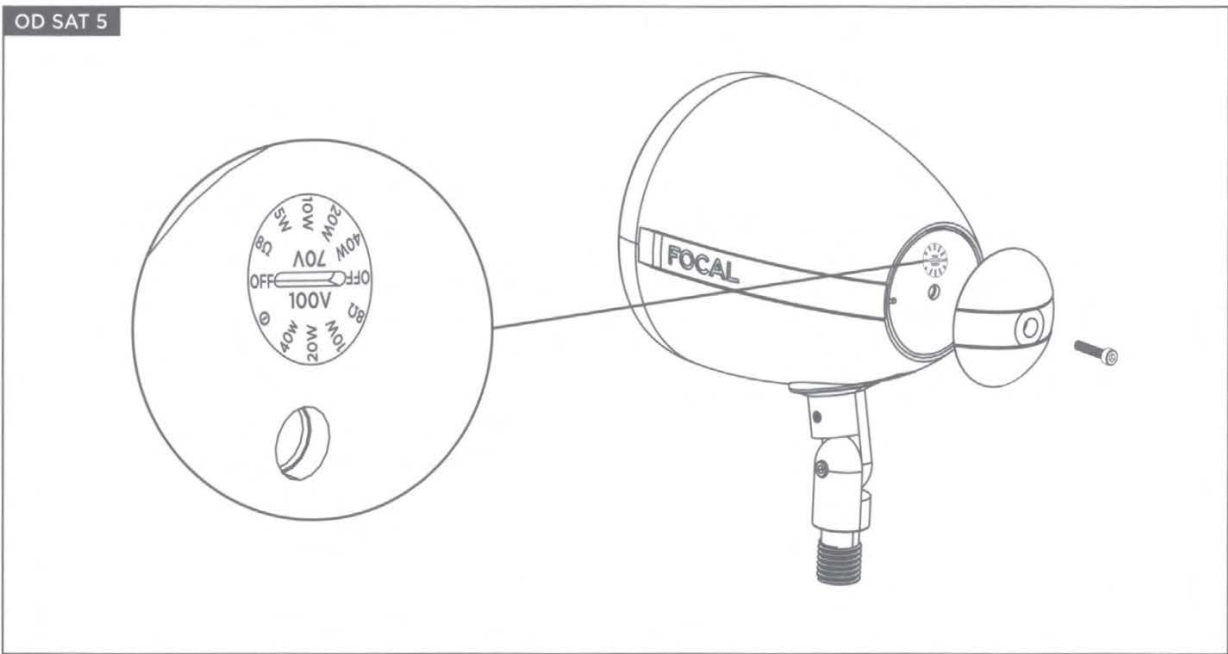

OD SAT 5

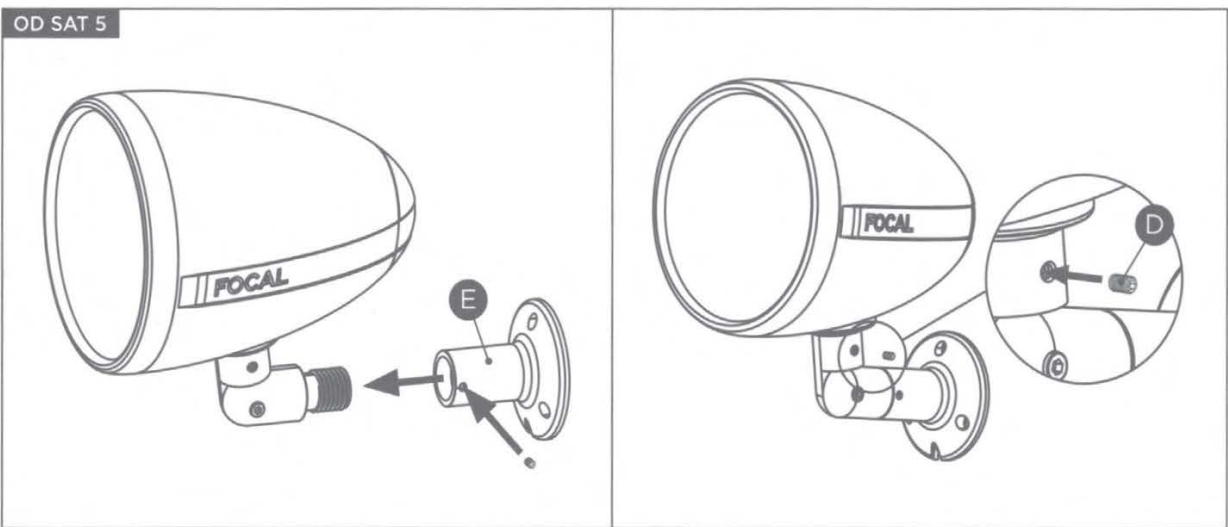

OD SAT 5 OPTION 1

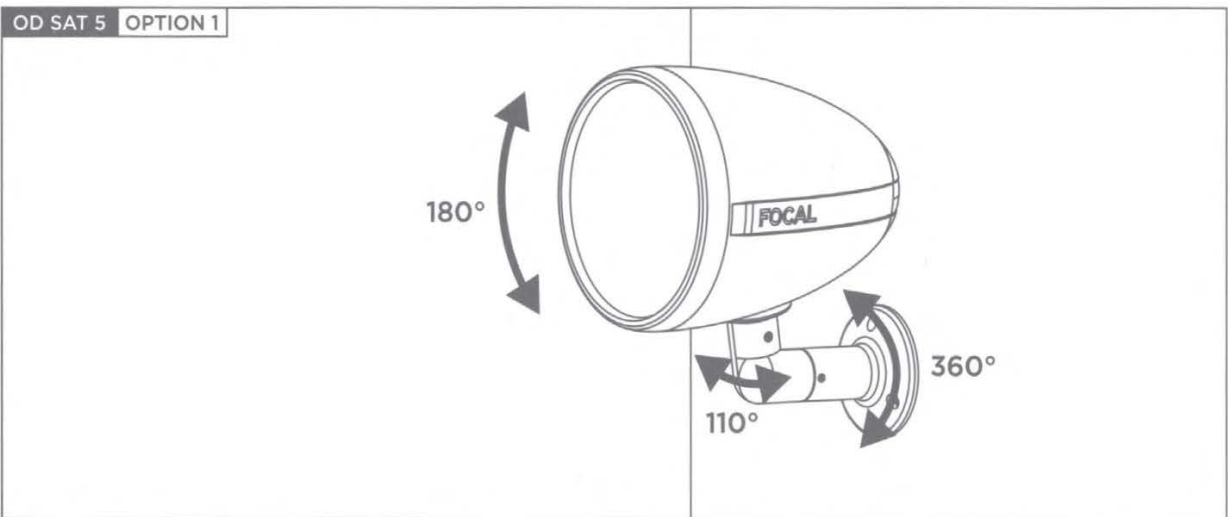

OD SAT 5 OPTION 2

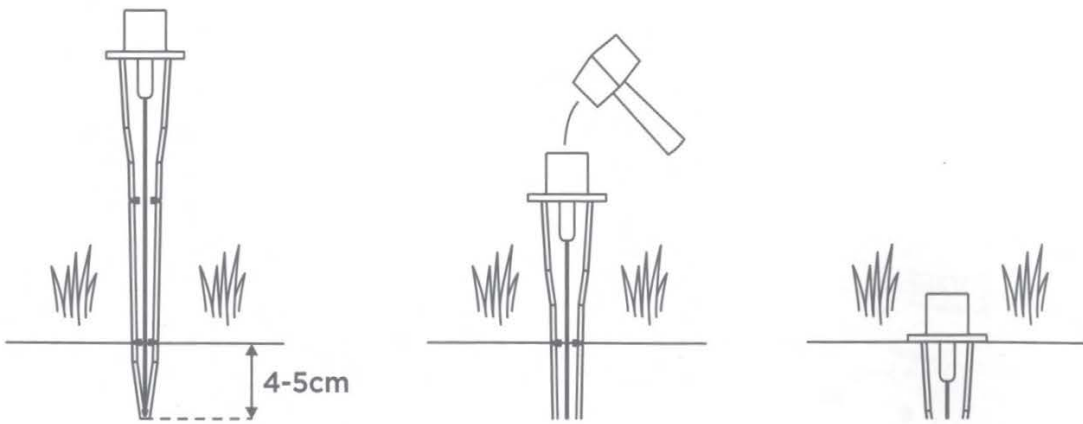
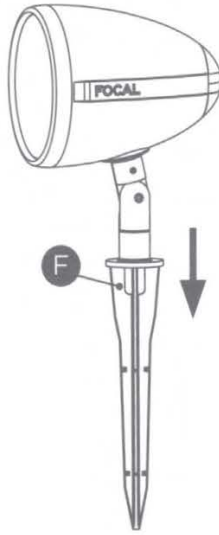

OD SUB 12

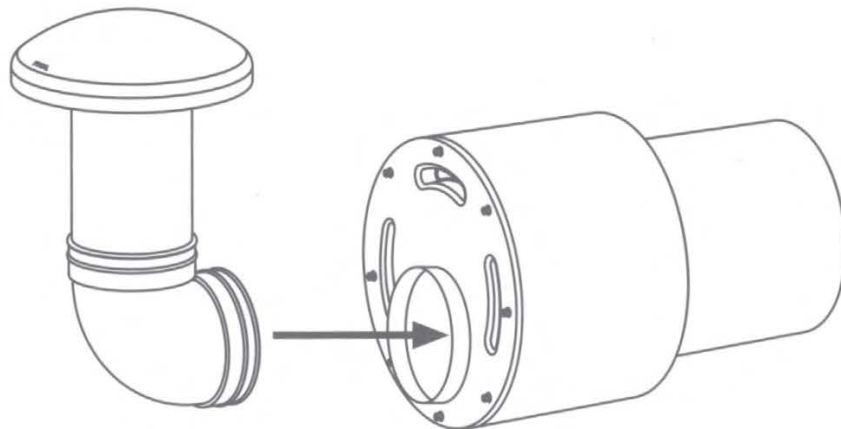

OD SUB 12

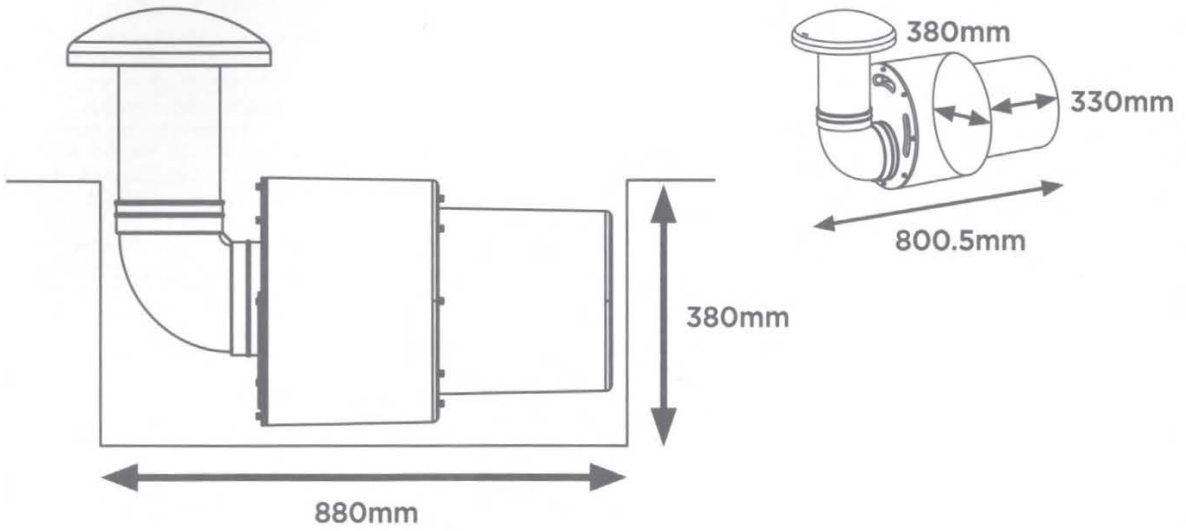

OD SUB 12

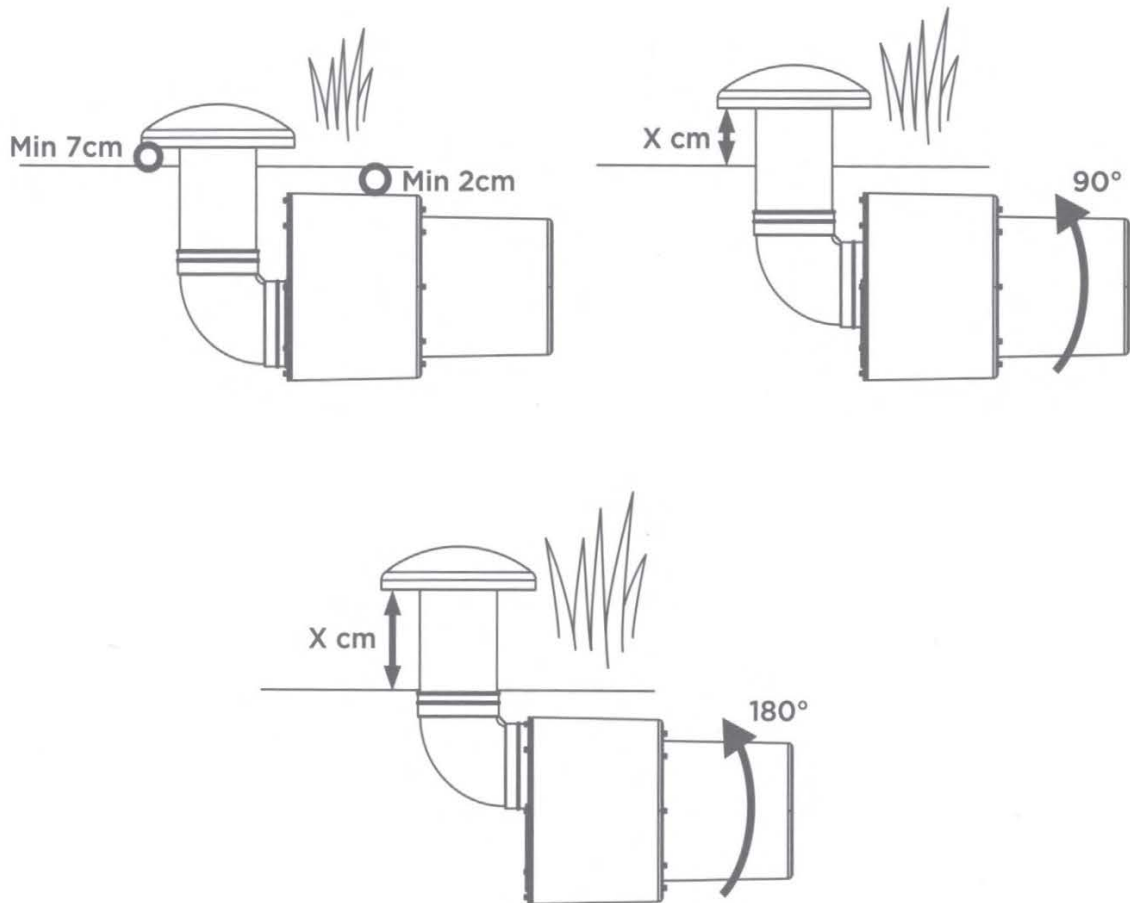

OD SUB 12

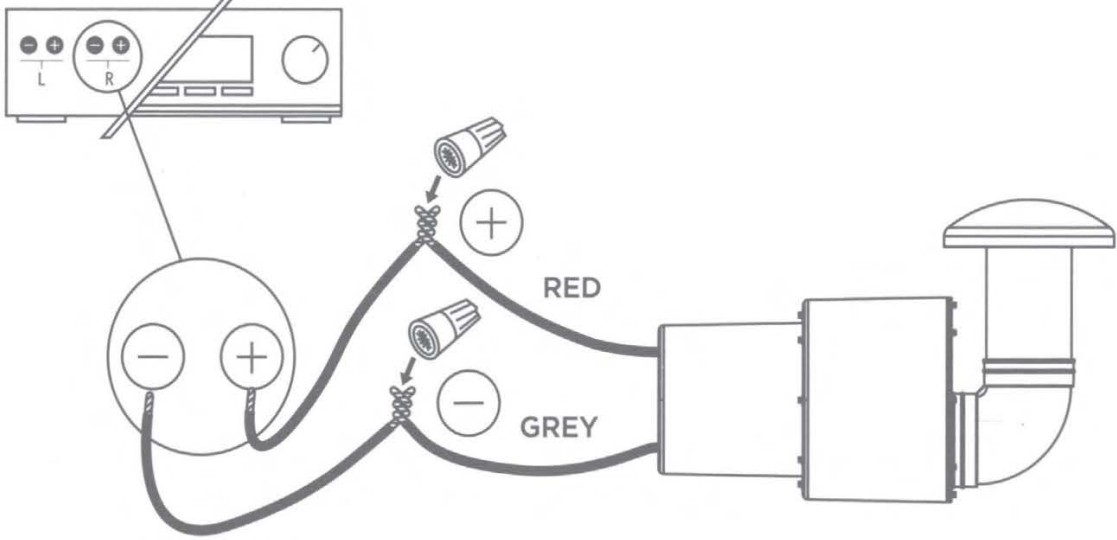

8Ω

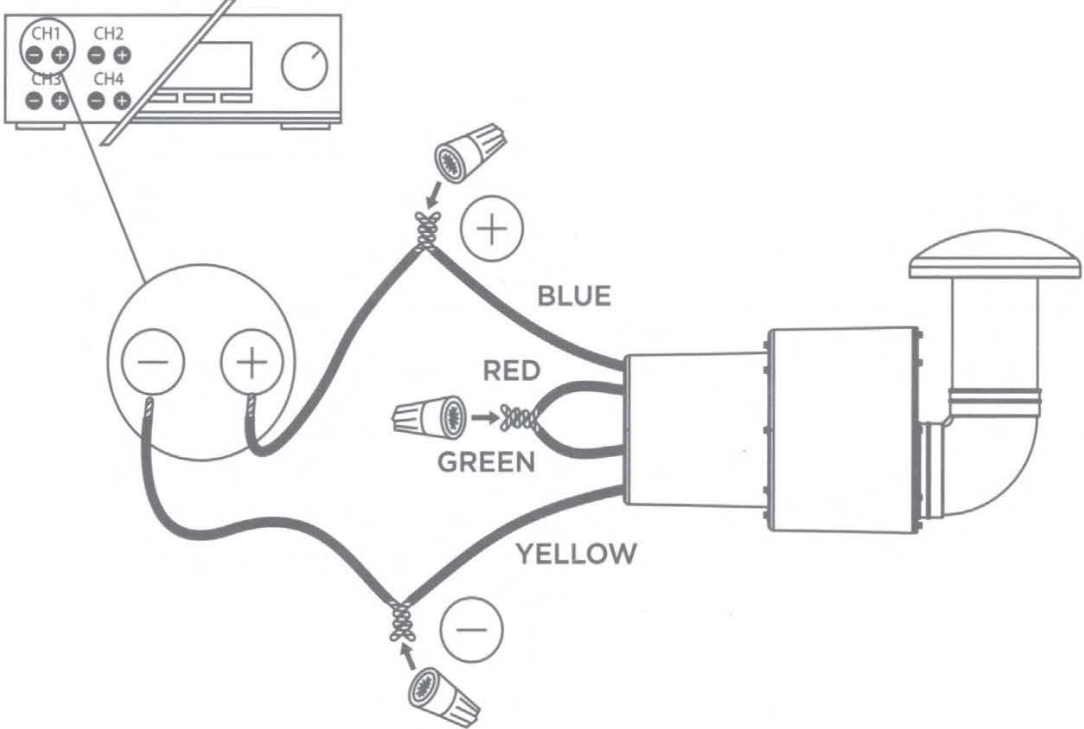

OD SUB 12

70/100V



	<p>Warning symbol. This symbol is designed to warn the user of the presence of important instructions mentioned in the user manual and relating to the handling, operation and maintenance of the device.</p>	
<ol style="list-style-type: none"> <li>1. Read these instructions.</li> <li>2. Keep these instructions.</li> <li>3. Heed all warnings.</li> <li>4. Follow all the instructions.</li> <li>5. After unpacking the product, ensure you do not leave the packaging within reach of children, as it poses a risk of suffocation.</li> <li>6. Only clean with a dry cloth.</li> <li>7. Do not obstruct ventilation openings. Follow the manufacturer's instructions for installing the device.</li> <li>8. Do not install the device close to a heat source (e.g. a cooking appliance, flame, etc.) or any other appliance (including amplifiers) that gives out heat. The device must not be exposed to temperatures above 65°C.</li> <li>9. Only use accessories recommended by the manufacturer.</li> <li>10. If cords or connectors are supplied, use them properly as described in the user manual without substituting them or modifying them.</li> <li>11. The methods of installing and mounting loudspeakers to any surface (bracket, ground anchoring, etc.) depend on the conditions and standards of construction, refurbishment, safety and cabling in force and applicable to the surfaces and/or brackets involved. In addition, the products may vibrate and damage the brackets onto which they are mounted. For this reason, the installation operations must be performed by a qualified professional who is familiar with installation and safety standards. Focal does not provide any end-of-use warranty for a given bracket or installation, as installing the loudspeakers is the customer's sole responsibility. Focal is therefore not liable in any capacity whatsoever in the event of an incident, accident and/or any other result or damage of any kind related to the installation of loudspeakers.</li> </ol>	<ol style="list-style-type: none"> <li>12. Only use suitable handling equipment, trolleys, stands, tripods, mounts or tables recommended by the manufacturer or sold with the device. If using a trolley, take extra care when moving the trolley and device together, to prevent the device from falling off and causing injury.</li> </ol>  <ol style="list-style-type: none"> <li>13. All maintenance tasks should be performed by a qualified professional. Maintenance is necessary following any damage caused to the device, such as damage to the cabling or the plug, objects inserted into the device, liquids spilled inside the device, or if the device is incorrectly operated or dropped.</li> <li>14. After any maintenance or repair work on the device, ask the maintenance technician to test it to check that it is working safely.</li> <li>15. If the product is damaged in any way, its IP certification will no longer be valid, so if any liquid or solid comes into contact with the product it could present a danger to the user or could damage a third-party electronic device connected to the product.</li> </ol>	<ol style="list-style-type: none"> <li>16. If a subwoofer is installed, it is essential that it is secured by attaching it firmly to the ground or to a wall. If the subwoofer is not properly secured, it could become a projectile and cause an accident. Securing this device is even more important if it is installed in an open space.</li> <li>17. Beware of buried and semi-buried components, or those running along the ground, as these pose a risk of obstacle, collision and/or fall. Do not allow children or frail individuals to approach them.</li> <li>18. Some users are not sufficiently independent to safely use the product alone, particularly children under 14 and people with certain disabilities. It is therefore imperative that they are supervised and assisted when using the device.</li> <li>19. To avoid damaging your hearing, do not listen to loudspeakers at high volumes for long periods of time. Listening to loudspeakers at high volumes can cause damage to the user's ears and may lead to hearing problems (temporary or permanent deafness, buzzing in the ears, tinnitus, hyperacusis). Exposure to excessive volumes (over 85dB) for more than one hour can cause irreparable damage to your hearing.</li> </ol>  <p>(CEI 60417-6044)</p>

### Conditions of warranty

All Focal loudspeakers are covered by warranty drawn up by the official Focal distributor in your country. Your distributor can provide all details concerning the conditions of warranty. Warranty cover extends at least to that granted by the legal warranty in force in the country where the original purchase invoice was issued.



**REGISTER YOUR  
PRODUCT ONLINE**



[www.focal.com/  
warranty](http://www.focal.com/warranty)

- FR** Enregistrez votre produit en ligne
- DE** Registrieren Sie Ihr Produkt online
- ES** Registre su producto en línea
- IT** Registra il tuo prodotto online
- PT** Possível registar um produto online
- NL** Registreer uw product online
- PO** Zarejestruj swój produkt online
- RU** Зарегистрируйте свой продукт онлайн
- ZH** 您可以在线注册产品
- KO** 당신의 제품을 온라인에서 등록하세요
- JP** 製品のオンライン登録をお願いします
- AR** يمكنك الآن تسجيل منتجك عبر الإنترنت



Aamp  
25B  
GU35 9QE



# LITTORA 200

## OD STONE 8 - OD SAT 5 - OD SUB 12

Manuel d'utilisation / User Manual / Gebrauchsanleitung /  
Manuale d'uso / Manual de uso / Manual de utilização /  
Handleiding / Instrukcja obsługi / Руководство по  
эксплуатации / 使用手册 / 用戶手冊  
사용 설명서 / 取扱説明書 / دليل المستخدم

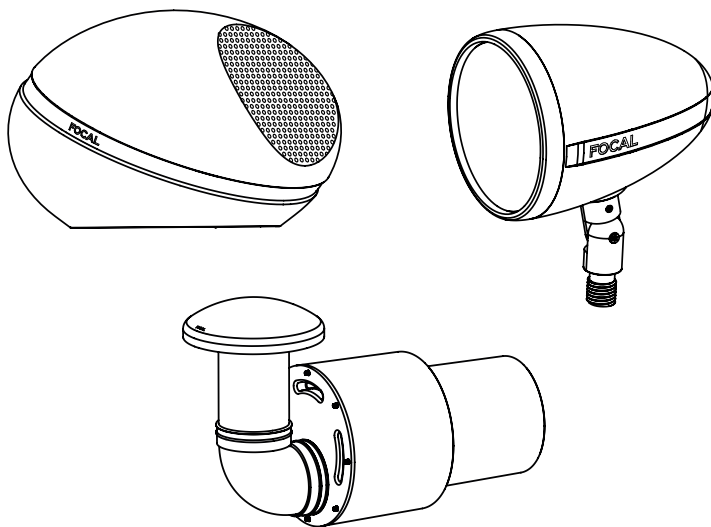

# LITTORA 200

Manuel d'utilisation / User manual

3

## OD STONE 8

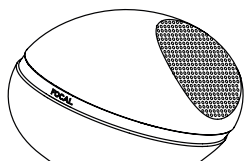

A  
x 1



B  
x 3



C  
x 1

1

## OD SAT 5

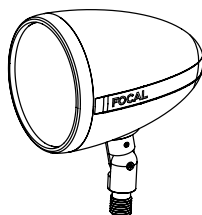

A  
x 1



D  
x 2



E  
x 1



C  
x 1

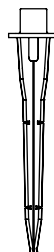

F  
x 1

2

## OD SUB 12

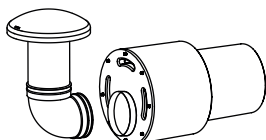

A  
x 1



B  
x 3



C  
x 1

3

# LITTORA 200

Manuel d'utilisation / User manual

4

OD STONE 8

8Ω

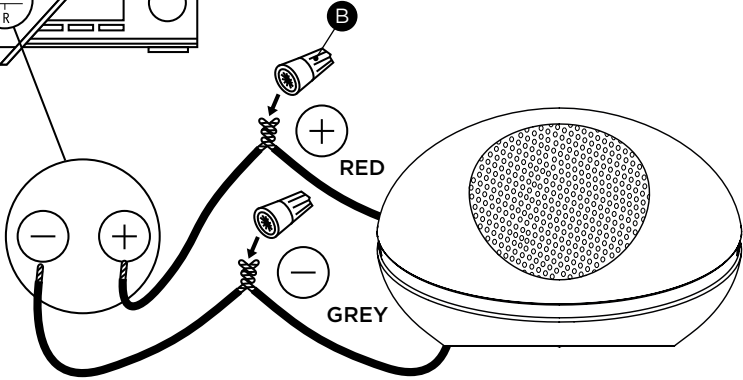
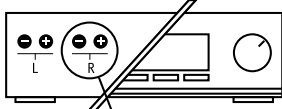

4

OD STONE 8

70/100V

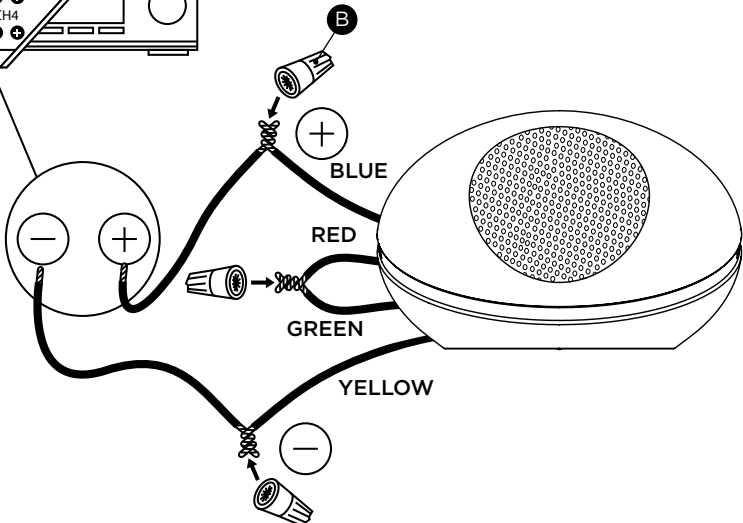
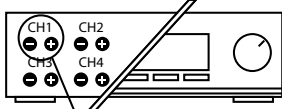

5

# LITTORA 200

Manuel d'utilisation / User manual

OD SAT 5

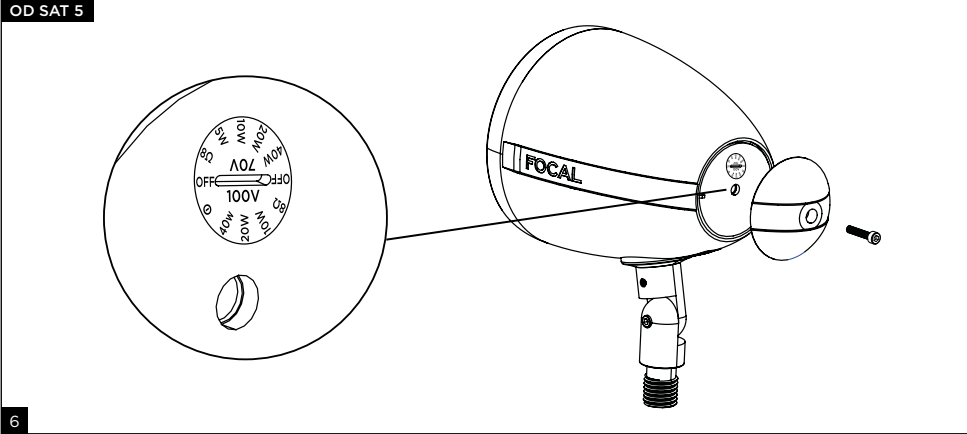

6

OD SAT 5

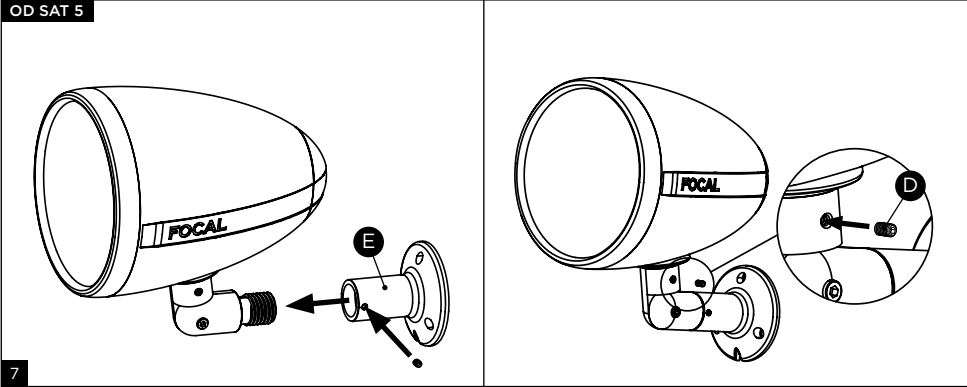

7

OD SAT 5 OPTION 1

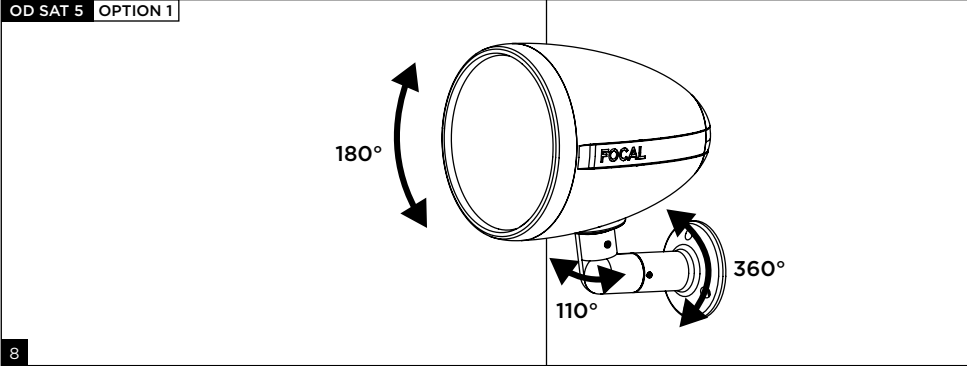

8

# LITTORA 200

Manuel d'utilisation / User manual

OD SAT 5 OPTION 2

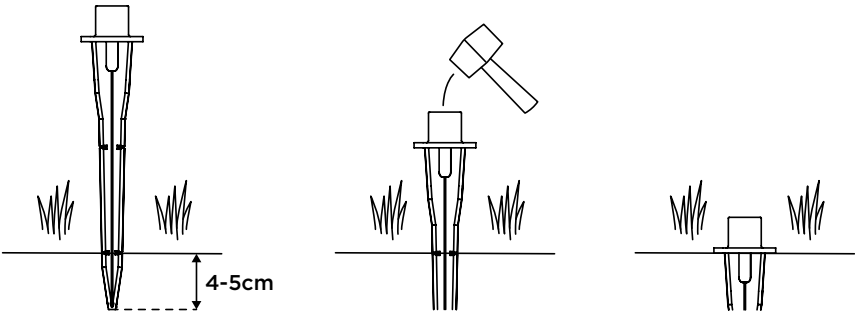
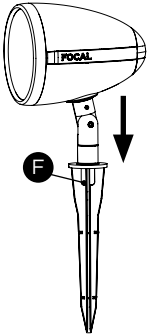

# LITTORA 200

Manuel d'utilisation / User manual

OD SUB 12

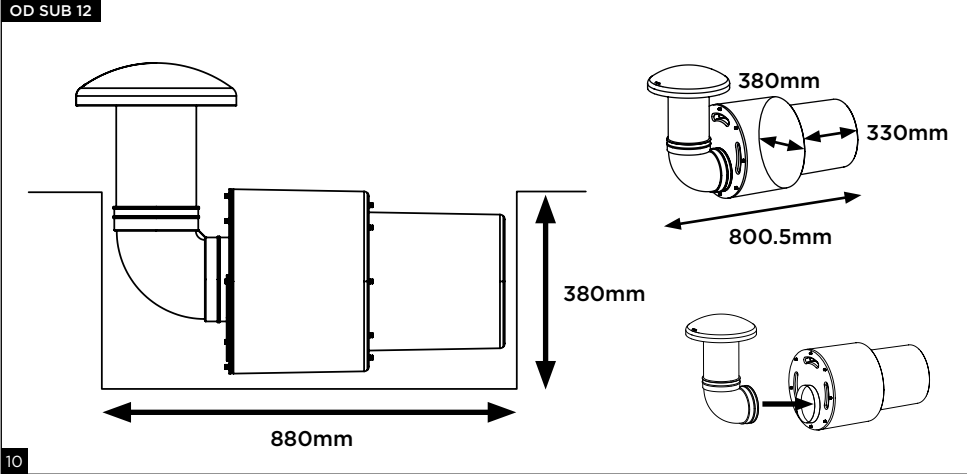

10

OD SUB 12

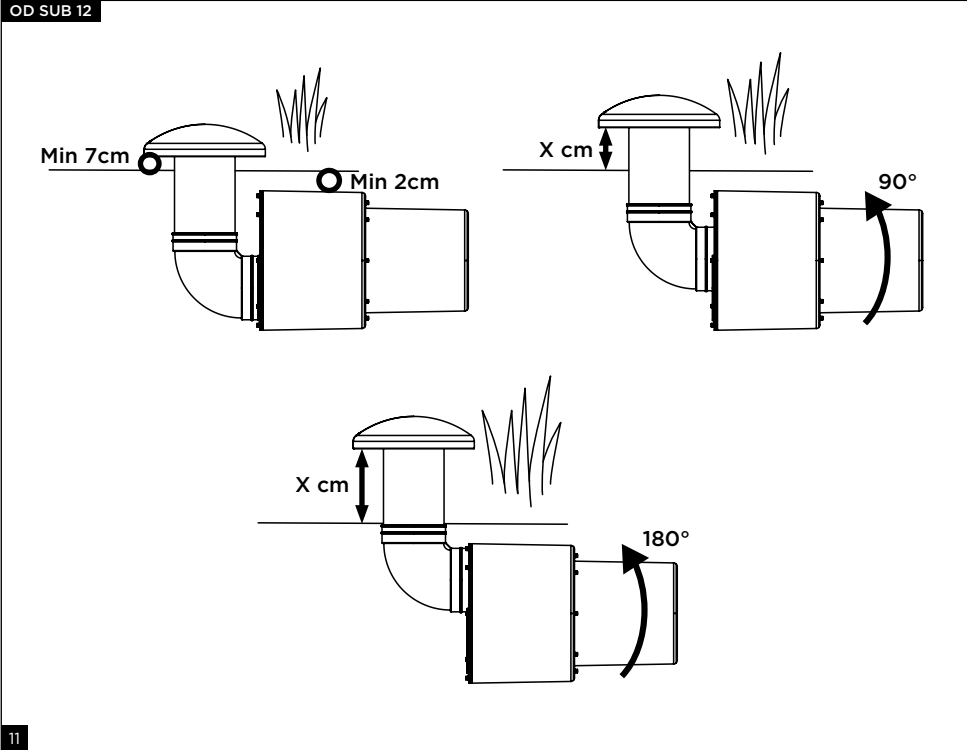

11

# LITTORA 200

Manuel d'utilisation / User manual

OD SUB 12

8Ω

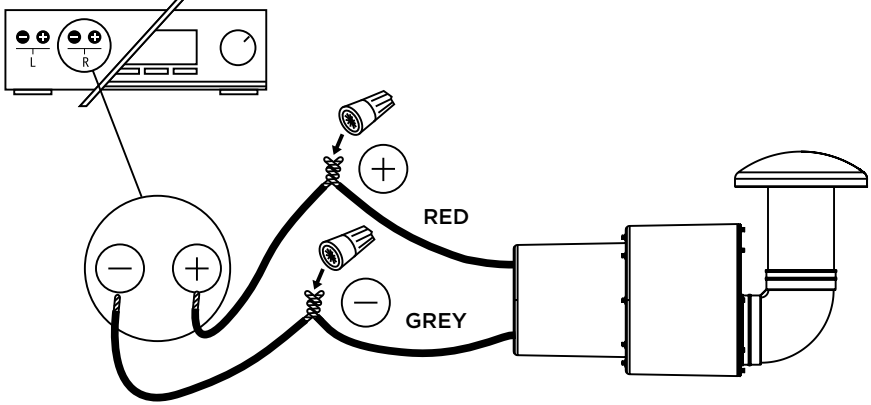

12

OD SUB 12

70/100V

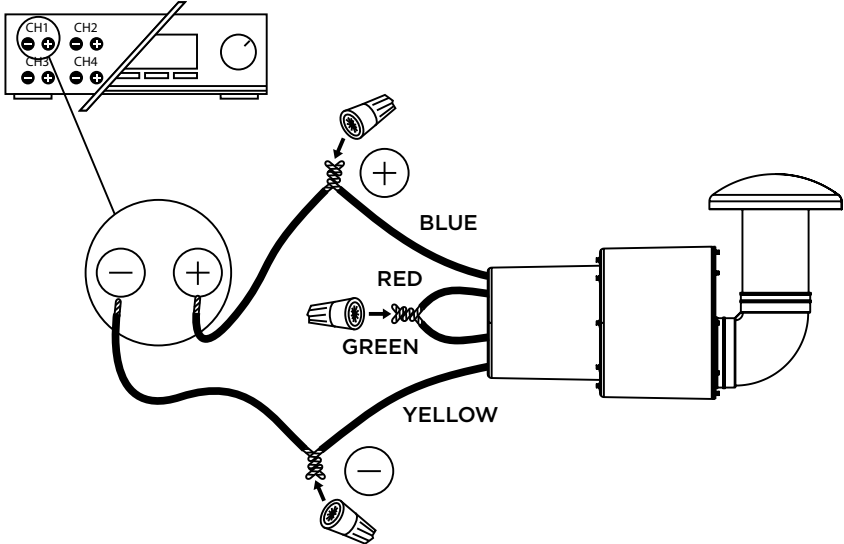

13



# LITTORA 200

Manuel d'utilisation / User manual

9

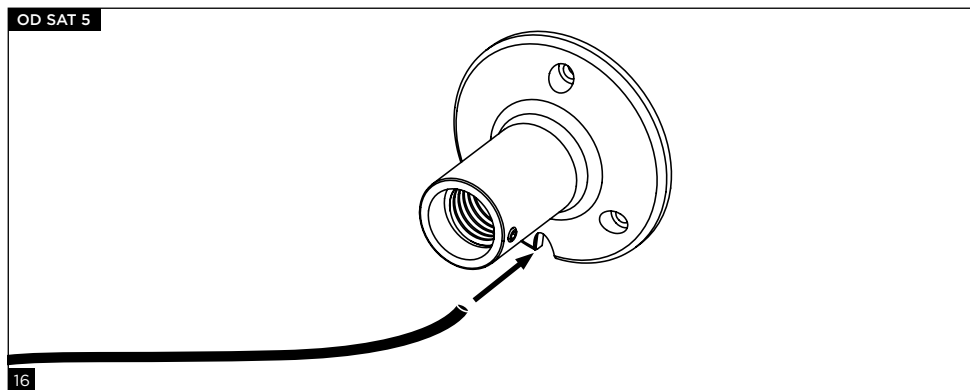
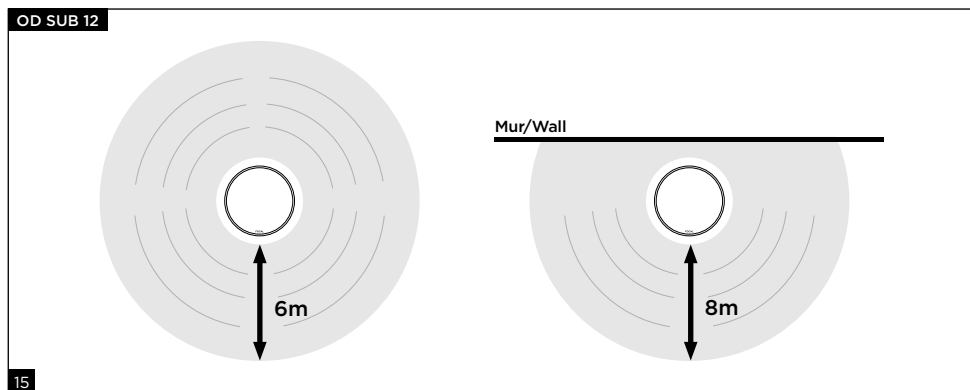
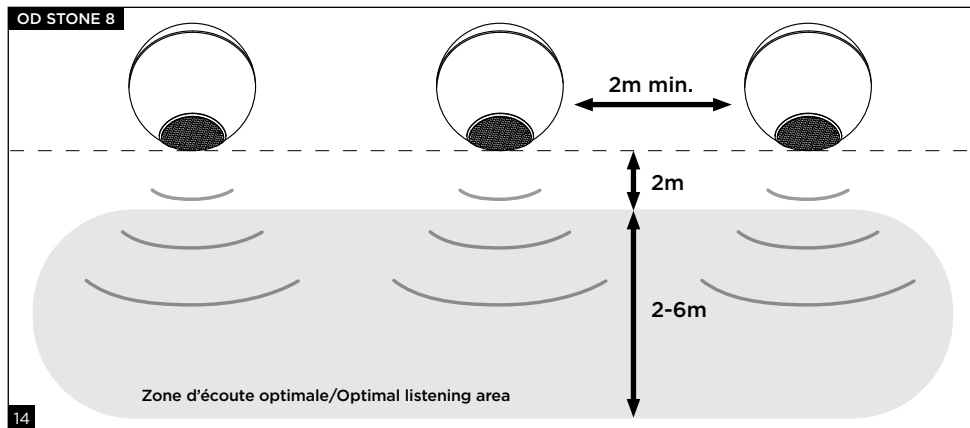

# LITTORA 200

## Caractéristiques / Specifications

10

LITTORA 200 OD SAT 5	
Type d'enceinte	Enceinte d'extérieur 2 voies
Haut-parleurs	Woofer 5" membrane Iris IP Tweeter 1" à profil «M» en aluminium
Bande passante	90 Hz - 28 kHz
Impédance	8 Ω
Impédance minimale	5.2 Ω à 250 Hz
Sensibilité	88 dB
Puissance	50 W RMS - 100 W Peak
Puissance ampli recommandé 8 Ω	20 W - 100 W
Positions transformateur	70 V - 100 V/5 W, 10 W, 20 W, 40 W
Tolérance en température	-20° / 65°
Indice IP	IP55
Couverture d'angle	90°
Dimensions (L x P x H)	32 x 21 x 32 cm
Poids	2,5 kg

LITTORA 200 OD SAT 5	
Type of speaker	2-way outdoor speaker
Speaker drivers	5" (12.7cm) Midbass, Iris IP cone 1" (2.5cm) Aluminium 'M'-shaped tweeter
Bandwidth	90Hz - 28kHz
Impedance	8Ω
Minimal impedance	5.2Ω at 250Hz
Sensitivity	88dB
Power	50W RMS - 100W Peak
Recommended amp power 8Ω	20W - 100W
Transformer positions	70V - 100V / 5W, 10W, 20W, 40W
Temperature tolerance	-20° / 65°
IP rating	IP55
Angle coverage	90°
Dimensions (WxDxH)	12 <sup>5/8</sup> "x8 <sup>1/4</sup> "x12 <sup>5/8</sup> " (32x21x32cm)
Weight	5.5lbs (2.5kg)

# LITTORA 200

## Caractéristiques / Specifications

11

LITTORA 200 OD STONE 8	
Type d'enceinte	Enceinte d'extérieur 2 voies
Haut-parleurs	Woofer 8" membrane Iris IP Tweeter 1" à profil «M» en aluminium
Bande passante	45 Hz - 28 kHz
Impédance	8 Ω
Impédance minimale	5.2 Ω à 180 Hz
Sensibilité	89 dB
Puissance en 8 Ω	75 W RMS - 150 W Peak
Puissance en 100 V	50 W
Puissance ampli recommandé 8 Ω	20 W - 150 W
Tolérance en température	-20° / 65°
Indice IP	IP55
Dimensions (L x P x H)	29 x 44 x 44 cm
Poids	6,5 kg

LITTORA 200 OD STONE 8	
Type of speaker	2-way outdoor speaker
Speaker drivers	8" (20cm) Midbass with Iris IP cone 1" (2.5cm) Aluminium 'M'-shaped tweeter
Bandwidth	45Hz - 28kHz
Impedance	8Ω
Minimal impedance	5.2Ω at 180Hz
Sensitivity	89dB
Power at 8Ω	75W RMS - 150W Peak
Power at 100V	50W
Recommended amp power 8Ω	20W - 150W
Temperature tolerance	-20° / 65°
IP rating	IP55
Dimensions (WxDxH)	11 <sup>3</sup> / <sub>8</sub> "x17 <sup>3</sup> / <sub>8</sub> "x17 <sup>3</sup> / <sub>8</sub> " (29x44x44cm)
Weight	14.3lbs (6.5kg)



# LITTORA 200

## Caractéristiques / Specifications

12

LITTORA 200 OD SUB 12	
Type d'enceinte	Caisson de basses extérieur
Haut-parleurs	Woofer 12" à membrane Iris IP
Bande passante	40 - 120 Hz
Impédance	6 $\Omega$
Impédance minimale	5 $\Omega$ à 55 Hz
Sensibilité	90 dB
Puissance	100 W RMS - 400 W Peak
Puissance ampli recommandé 8 $\Omega$	50 W - 300 W
Tolérance en température	-20° / 65°
Indice IP	IP55
Dimensions (L x P x H)	38 x 92 x 56 cm
Poids	19 kg

LITTORA 200 OD SUB 12	
Type of speaker	Outdoor subwoofer
Speaker drivers	12" (30cm) woofer with Iris IP cone
Bandwidth	40Hz - 120Hz
Impedance	6 $\Omega$
Minimal impedance	5 $\Omega$ at 55Hz
Sensitivity	90dB
Power	100W RMS - 400W Peak
Recommended amp power 8 $\Omega$	50W - 300W
Temperature tolerance	-20° / 65°
IP rating	IP55
Dimensions (WxDxH)	15"x36 <sup>1/4</sup> "x22" (38x92x56cm)
Weight	41.89lbs (19kg)

	<p>Warning symbol. This symbol is designed to warn the user of the presence of important instructions mentioned in the user manual and relating to the handling, operation and maintenance of the device.</p>	
<ol style="list-style-type: none"> <li>1. Read these instructions.</li> <li>2. Keep these instructions.</li> <li>3. Heed all warnings.</li> <li>4. Follow all the instructions.</li> <li>5. After unpacking the product, ensure you do not leave the packaging within reach of children, as it poses a risk of suffocation.</li> <li>6. Only clean with a dry cloth.</li> <li>7. Do not obstruct ventilation openings. Follow the manufacturer's instructions for installing the device.</li> <li>8. Do not install the device close to a heat source (e.g. a cooking appliance, flame, etc.) or any other appliance (including amplifiers) that gives out heat. The device must not be exposed to temperatures above 65°C.</li> <li>9. Only use accessories recommended by the manufacturer.</li> <li>10. If cords or connectors are supplied, use them properly as described in the user manual without substituting them or modifying them.</li> <li>11. The methods of installing and mounting loudspeakers to any surface (bracket, ground anchoring, etc.) depend on the conditions and standards of construction, refurbishment, safety and cabling in force and applicable to the surfaces and/or brackets involved. In addition, the products may vibrate and damage the brackets onto which they are mounted. For this reason, the installation operations must be performed by a qualified professional who is familiar with installation and safety standards. Focal does not provide any end-of-use warranty for a given bracket or installation, as installing the loudspeakers is the customer's sole responsibility. Focal is therefore not liable in any capacity whatsoever in the event of an incident, accident and/or any other result or damage of any kind related to the installation of loudspeakers.</li> </ol>	<ol style="list-style-type: none"> <li>12. Only use suitable handling equipment, trolleys, stands, tripods, mounts or tables recommended by the manufacturer or sold with the device. If using a trolley, take extra care when moving the trolley and device together, to prevent the device from falling off and causing injury.</li> </ol>  <ol style="list-style-type: none"> <li>13. All maintenance tasks should be performed by a qualified professional. Maintenance is necessary following any damage caused to the device, such as damage to the cabling or the plug, objects inserted into the device, liquids spilled inside the device, or if the device is incorrectly operated or dropped.</li> <li>14. After any maintenance or repair work on the device, ask the maintenance technician to test it to check that it is working safely.</li> <li>15. If the product is damaged in any way, its IP certification will no longer be valid, so if any liquid or solid comes into contact with the product it could present a danger to the user or could damage a third-party electronic device connected to the product.</li> </ol>	<ol style="list-style-type: none"> <li>16. Beware of buried and semi-buried components, or those running along the ground, as these pose a risk of obstacle, collision and/or fall. Do not allow children or frail individuals to approach them.</li> <li>17. Some users are not sufficiently independent to safely use the product alone, particularly children under 14 and people with certain disabilities. It is therefore imperative that they are supervised and assisted when using the device.</li> <li>18. To avoid damaging your hearing, do not listen to loudspeakers at high volumes for long periods of time. Listening to loudspeakers at high volumes can cause damage to the user's ears and may lead to hearing problems (temporary or permanent deafness, buzzing in the ears, tinnitus, hyperacusis). Exposure to excessive volumes (over 85dB) for more than one hour can cause irreparable damage to your hearing.</li> </ol>  <p>(CEI 60417-6044)</p>



The methods of installing and mounting loudspeakers to any surface (bracket, ground anchoring, etc.) depend on the conditions and standards of installation, refurbishment, safety and cabling in force and applicable to the surfaces and/or brackets involved. In addition, the products may vibrate and damage the brackets onto which they are mounted. For this reason, the installation operations must be performed by a qualified professional who is familiar with installation and safety standards. Focal does not provide any end-of-use warranty for a given bracket or installation, as installing the loudspeakers is the customer's sole responsibility. Focal is therefore not liable in any capacity whatsoever in the event of incident, accident and/or any other result or damage of any kind related to the installation of loudspeakers.

This device complies with part 15 of the FCC Rules. Operation is subject to the following two conditions: (1) this device may not cause harmful interference, and (2) this device must accept any interference received, including interference that may cause undesired operation.

Changes or modifications not expressly approved by the party responsible for compliance could void the user's authority to operate the equipment. NOTE: This equipment has been tested and found to comply with the limits for a Class B digital device, pursuant to Part 15 of the FCC Rules. These limits are designed to provide reasonable protection against harmful interference in a residential installation. This equipment generates, uses and can radiate radio frequency energy and, if not installed and used in accordance with the instructions, may cause harmful interference to radio communications. However, there is no guarantee that interference will not occur in a particular installation. If this equipment does cause harmful interference to radio or television reception, which can be determined by turning the equipment off and on, the user is encouraged to try to correct the interference by one or more of the following measures:

- Reorient or relocate the receiving antenna.
- Increase the separation between the equipment and receiver.
- Connect the equipment into an outlet on a circuit different from that to which the receiver is connected.
- Consult the dealer or an experienced radio/TV technician for help.

# LITTORA 200

## User manual

19

EN

Please validate your Focal-JMLab warranty, it is now possible to register your product online at: [www.focal.com/garantie](http://www.focal.com/garantie)



Thank you for purchasing a Focal product. Welcome to our world, the world of High-Fidelity. Innovation, tradition, excellence and pleasure are our values; our one and only aim is to bring you a sound that is rich, pure and true. To get the most out of your product, we recommend that you read the instructions in this booklet, then store it in a safe place to refer to in the future.

### Package contents:

#### OD STONE 8 (fig. 1)

- 1 x loudspeaker
- 1 x circular grille
- 1 x waterproof cables connector
- 1 x quickstart guide (quick-start guide)
- 1 x set of safety instructions and warranty terms and conditions

#### OD SAT 5 (fig. 2)

- 1 x loudspeaker
- 3 x waterproof cables connector
- 2 x screws
- 1 x wall bracket
- 1 x stake
- 1 x quickstart guide (quick-start guide)
- 1 x set of safety instructions and warranty terms and conditions

#### OD SUB 12 (fig. 3)

- 1 x subwoofer
- 3 x waterproof cables connector
- 1 x quickstart guide (quick-start guide)
- 1 x set of safety instructions and warranty terms and conditions

### Key points:

#### OD STONE 8

- Modern, elegant design that blends seamlessly into your outdoor space
- IP55-certified technical design (water and dust)
- 8" woofer with Iris IP cone and 1" aluminium 'M'-shaped inverted dome tweeter
- Hanging loop
- Compatible 8Ω/70V/100V
- Compatible with OD SAT 5 and OD SUB 12 for an allround system

#### OD SAT 5

- Discreet design that blends seamlessly into your outdoor space
- IP55-certified technical design (water and dust)
- 5" woofer with Iris IP cone and 1" aluminium 'M'-shaped inverted dome tweeter
- Brackets supplied for in-ground or in-wall installation
- Compatible 8Ω/70V/100V
- Compatible with OD SUB 12 for more bass

#### OD SUB 12

- Robust design
- IP55-certified technical design (water and dust)
- 12" woofer with Iris IP cone: A deep and powerful 400W bass
- Adjustable height
- Compatible with OD STONE 8 and OD SAT 5 for an allround system

# LITTORA 200

## User manual

20

EN

### CHOOSING AN AMPLIFIER

#### In an 8Ω Amplifier configuration:

It is not an excess of amplifier power that can damage your loudspeaker and drivers, but rather a lack of power. In fact, if the volume is too high, the amplifier saturates and generates parasite signals that may destroy the tweeter. The dynamic capacity and definition of Littora loudspeakers are high enough to reveal the strengths and weaknesses of whatever amplifier is connected to them. Your dealer will be able to guide you, depending on your tastes and budget.

#### In a 70V/100V Amplifier configuration:

It is recommended to use an amplifier that delivers 20% more power than the system's total power to avoid a surge or damage to Littora products. Your retailer will be able to guide you depending on your tastes and budget.



An amplifier used at full power, combined with a 70V/100V transformer, can deliver dangerous voltages. Always disconnect the power from the amplifier and the transformer before handling, to avoid any risk of electric shock.

Follow the recommendations and instructions/configuration of your amplifier in order to correctly connect each Littora 200 loudspeaker.

#### Cable choice

Choose good quality cables with a cross-section appropriate for outdoor installation: your dealer will be able to advise you.

### LOUDSPEAKER POSITIONING

#### OD STONE 8/OD SAT 5

The loudspeakers should be arranged, evenly spaced, in a line or arc in order to cover the listening area as best as possible. The space between two loudspeakers will be at least 6.5ft (2m) for a listening station measuring between 6.5ft - 19.6ft (2-6m) (**fig. 14**). However, it is possible to vary these distances to find an ideal compromise depending on the space layout.

#### OD SUB 12

To supply the listening area as best as possible, place the OD SUB 12 as close as possible to the centre of the system, avoiding any pools (fountains, swimming pools, water sources, etc.). The optimal listening zone is a radius of 16.6ft (6m) around the sub. For more bass, place it closer to a wall (**fig. 15**).

### INSTALLATION

Before installing the loudspeakers, ensure that the intended positions on the ceiling/wall/ground are not obstructed by the passage of air vents, for example, or any cables that may interfere with the installation.

These products are IP55 certified for increased water and dust-resistance. To protect their service life do not expose them to constantly running water and never immerse them in water. After heavy rainfall, we recommend waiting a few hours before turning them on again; allowing them to dry-out naturally will restore nominal audio functioning.

#### OD STONE 8

The design of the OD STONE 8 allows it to be placed on any surface without mounting. It can either be placed or fixed using its attachment loop located on the base.

# LITTORA 200

## User manual

21

NE

### WALL-MOUNTING

#### OD SAT 5 (fig.7)

Before hanging the products, make sure the ceiling/walls are strong, in perfect condition, and are suitable to remain so long-term. Use a professional to fix the wall brackets (**E**) and only use screws and dowels suitable for the materials. To mount the loudspeakers, securely fasten the bracket using screws suitable for the materials. For a more discreet installation, thread the cable through the hole in the middle of the mounting bracket and the notch on the base (**fig. 16**). Make sure to leave around 1<sup>3</sup>/<sub>4</sub>" (30cm) of cable to allow you to connect and position the loudspeaker easily afterwards. Next, direct the loudspeaker towards the listening area and tighten the joints firmly with the locking screws (**fig. 8**).

### GROUND MOUNTING

#### OD SAT 5 (fig. 9)

Mounting in the ground is only possible in soil or sand. They cannot be mounted in rigid metal, wood or concrete floors. Take the stake (**F**) provided and plant it using your hand around 4-5cm into the ground. Then drive the stake in as far as it will go using a suitable tool. For a more discreet installation, thread the cable through the hole in the middle and the opening on the bottom of the stake. Make sure to leave around 1<sup>3</sup>/<sub>4</sub>" (30cm) of cable to allow you to connect and position the loudspeaker easily afterwards. The stake can be cut down for installations in shallow ground. To help cut it, there are notches on the stake at 4" and 7<sup>7</sup>/<sub>8</sub>" (10 and 20cm).

**Attention:** cutting the stake will create sharp edges which could cause injury.

Next, direct the loudspeaker towards the listening area and tighten the joints firmly with the locking screws (**fig. 8**).

#### OD SUB 12

To supply the listening area as best as possible, place the OD SUB 12 as close as possible to the centre of the system, avoiding any pools (fountains, swimming pools, water sources, etc.). For more bass, move the OD SUB 12 nearer a wall (**fig. 15**). Prepare the space for the sub by digging a hole measuring 13x34<sup>5</sup>/<sub>8</sub>x15" (330x880x380mm) (**fig. 10**).

**Positioning (fig. 10 and 11):** To get the most out of the sub, make sure there is a minimum 2<sup>3</sup>/<sub>4</sub>" (7cm) between the ground and the part above the ground. Adjust the height of the vent to suit you by twisting it whilst positioned in its location. Then cover the body with around 3/4" (2cm) of soil.

**Warning:** This product is only intended for use with the body underground.

### CONNECTIONS

#### OD STONE 8

With its 5-strand cable, the OD STONE 8 adapts perfectly to 70/100V (**fig. 5**) or 8Ω (**fig. 4**) amplification. To do this, make the appropriate connections using the waterproof cable connectors provided (**B**). To avoid any signal disturbance, ensure that any strands that are not used are electrically insulated using suitable equipment.

	+	-	Short circuit
8Ω	Red	Grey	None
70/100V	Blue	Yellow	Red and Green

#### OD SAT 5

The power of the OD SAT 5 is adjusted using the two-position notched selector on the back. To access it, remove the screw on the back of the satellite (**fig. 6**).

Each position selects two values. It is the type of amplifier connected to the speaker that determines the power emitted by the speaker.



# LITTORA 200

## User manual

22

EN

Example: In the 20W/40W position, a 70V amplifier will deliver 20W while a 100V amplifier will deliver 40W.

<b>8Ω</b>					
<b>70V</b>	5W	10W	20W	40W	OFF
<b>100V</b>	10W	20W	40W	∅	OFF

### 8 Ω

Dedicated position for a traditional 8Ω hi-fi amplifier.

### 5W/100 W, 10W/20 W, 20W/40 W and 40W/∅

In these positions you can use a 70V or 100V amplifier.

### ∅ Do not use



This position requires the use of a 70V amplifier only. Using a 100V amplifier may damage the loudspeaker and the amplifier.

### OFF

Default position No link is active.

### OD SUB 12

With its 5-strand cable, the OD SUB 12 adapts perfectly to 70/100V (**fig. 5**) or 8Ω (**fig. 12**) amplification. To do this, make the appropriate connections using the waterproof cable connectors provided (**B**).

To avoid any signal disturbance, ensure that any strands that are not used are electrically insulated using suitable equipment.

	<b>+</b>	<b>-</b>	<b>Short circuit</b>
<b>8Ω</b>	Red	Grey	None
<b>70/100V</b>	Blue	Yellow	Red and Green

## SPECIAL PRECAUTIONS

### Running-in period

The speaker drivers used in the Littora range of loudspeakers are complex mechanical assemblies which need a running-in period to operate at their best and to become acclimatised to the temperature and humidity of your environment. This running-in period varies depending on the conditions in question and may take several weeks. To reduce this time, we recommend operating your loudspeakers for about 20 consecutive hours at a moderate volume. Once the loudspeakers' characteristics have totally stabilised, you will be able to enjoy your Littora loudspeakers' performance to the full.

### Conditions of warranty

All Focal loudspeakers are covered by warranty drawn up by the official Focal distributor in your country. Your distributor can provide all details concerning the conditions of warranty. Warranty cover extends at least to that granted by the legal warranty in force in the country where the original purchase invoice was issued.



#### Élimination correcte de ce produit.

Ce marquage indique que ce produit ne doit pas être éliminé avec les autres déchets ménagers au sein de l'UE. Par mesure de prévention pour l'environnement et pour la santé humaine, veuillez le recycler de manière responsable, pour favoriser la réutilisation des ressources matérielles. Pour retourner votre appareil usé, veuillez utiliser les systèmes de retour et de collecte ou contactez le détaillant chez lequel le produit a été acheté. Celui-ci pourra procéder au recyclage du produit en toute sécurité.



#### Correct elimination of this product.

This marking indicates that within the EU this product should not be disposed of with other household wastes. To prevent any risk to the environment or human health, please recycle them responsibly to encourage the reuse of material resources. To return your used device, please use the return and collection systems available, or contact the retailer where you purchased the product. They can recycle this product safely.



#### Ordnungsgemäße Entsorgung des Produkts.

Diese Kennzeichnung weist darauf hin, dass dieses Produkt innerhalb der EU nicht mit anderen Haushaltsabfällen entsorgt werden darf. Als Präventivmaßnahme für die Umwelt und die menschliche Gesundheit muss auf eine verantwortungsbewusste Wiederverwertung zur Förderung der Wiederverwendung von materiellen Ressourcen geachtet werden. Für die Rückgabe von Gebrauchsgütern verwenden Sie bitte zur Verfügung stehende Rückgabe- und Recyclingsysteme oder wenden Sie sich an den Händler, bei dem Sie das Produkt erworben haben. Letzterer kann das Gerät sicher dem Wertstoffkreislauf zuführen.



#### Eliminación correcta de este producto.

Este símbolo indica que este producto no debe eliminarse con el resto de residuos domésticos dentro de la UE. Con el objetivo de proteger el medioambiente y la salud pública, recicle de forma responsable para favorecer la reutilización de los recursos materiales. Para devolver su aparato usado, utilice los sistemas de devolución y recogida o póngase en contacto con el vendedor del producto. Este podrá proceder al reciclaje del producto de forma totalmente segura.



#### Corretto smaltimento di questo prodotto.

Questa marcatura indica che, nell'UE, questo prodotto non deve essere smaltito insieme agli altri rifiuti domestici. A titolo preventivo per l'ambiente e la salute, deve essere riciclato in modo responsabile per favorire il riutilizzo delle risorse materiali. Per mandare indietro l'apparecchio usato, si prega di utilizzare il sistema di reso e raccolta o di contattare il rivenditore da cui è stato acquistato il prodotto, il quale potrà procedere a riciclare il prodotto in totale sicurezza.



#### Eliminação correta deste produto.

Esta marca indica que, na UE, este produto não deve ser eliminado com outro lixo doméstico. Como medida de prevenção para o ambiente e para a saúde humana, deve ser reciclado de modo responsável, para promover a reutilização dos recursos materiais. Para devolver o seu dispositivo usado, recorra aos sistemas de devolução e recolha ou contacte o comerciante em que o produto foi adquirido. Este poderá proceder à reciclagem do produto com toda a segurança.



#### Prawidłowe użycie produktu.

To oznaczenie informuje, że produktu nie należy usuwać wraz z innymi odpadami z gospodarstwa domowego na terenie UE. W celu ochrony środowiska i zdrowia człowieka, należy w sposób odpowiedzialny prowadzić recykling i wspierać ponowne wykorzystywanie materiałów. Aby zwrócić swoje urządzenie, należy skorzystać z systemu zwrotu i odbioru prowadzonego przez sprzedawcę detalicznego, u którego produkt został nabyty. Sprzedawca będzie w stanie w sposób bezpieczny przeprowadzić recykling produktu.



#### Tuotteen asianmukainen hävittäminen.

Tämä merkintä osoittaa, että EU:ssa tätä tuotetta ei saa hävittää muiden kotitalousjätteiden mukana. Kierrätä se vastuullisesti ehkäistäkseen mahdollisia vaaroja ympäristölle tai ihmisten terveydelle ja edistääkseen aineellisten voimavarojen uudelleenkäyttöä. Palauta käytetty laite käyttämällä saatavilla olevia palautus- ja keräysjärjestelmiä tai ota yhteys jälleenmyyjään, jolta ostit tuotteen. He voivat kierrättää tämän tuotteen turvallisesti.



#### Правильная утилизация продукта.

Данная маркировка указывает на то, что в пределах ЕС этот продукт не может утилизироваться вместе с бытовым мусором. В целях предотвращения загрязнения окружающей среды и нанесения ущерба здоровью человека утилизируйте продукт должным образом, позволяющим произвести его повторную переработку. Для того чтобы вернуть бывшее в употреблении устройство, используйте системы возврата и сбора сырья либо обратитесь в пункт розничной торговли, в котором вы приобрели продукт, для организации повторной переработки с соблюдением всех норм безопасности.



#### Correcte verwijdering van dit product.

Deze markering geeft aan dat dit product in de EU niet samen met ander huishoudelijk afval mag worden weggegooid. Om het milieu en de gezondheid van de mens te beschermen, dient u het product op verantwoorde wijze te recyclen om hergebruik van materiële hulpbronnen te stimuleren. U kunt uw gebruikte apparaat retourneren bij een recyclepunt of milieustation, of neem contact op met de winkel waar u het product hebt gekocht. Zo kan het product op verantwoorde wijze worden gerecycled.



**UK** Aamp  
**CA** 25B  
GU35 9QE



# LITTORA 200 OD STONE 8

## Product Sheet

The OD Stone 8 loudspeaker takes the Focal sound into your outdoor spaces! Its 8" (20cm) unprecedented Iris IP cone and its Aluminium 'M'-shaped inverted dome tweeter deliver faithful sound reproduction and a broad bandwidth. Its integrated transformer also makes it 70/100V compatible and can cover large spaces with no loss of power. Finally, with its IP55 certification and anti-UV treatment, OD Stone 8 withstands adverse weather and extreme climates. With its sophisticated design and finishes that combine elegance with modernity, it's at home in any surroundings. Its finishes (Basalt, Sand and Limestone) are textured: resembling rock, they blend seamlessly into outdoor spaces.

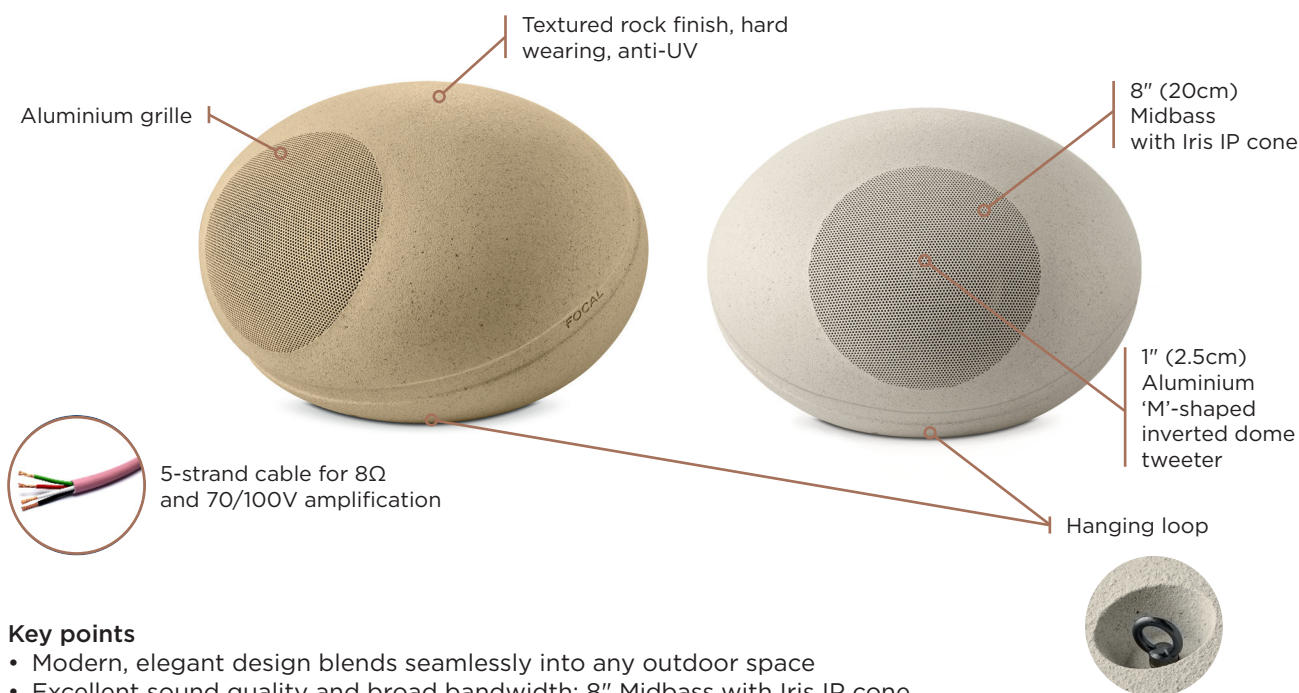

### Key points

- Modern, elegant design blends seamlessly into any outdoor space
- Excellent sound quality and broad bandwidth: 8" Midbass with Iris IP cone and 1" Aluminium 'M'-shaped inverted dome tweeter
- Loudspeaker that combines perfectly with an OD Sat 5 and OD Sub 12 system
- Mounted and held in place thanks to its hanging loop
- IP55-certified technical design (water and dust)
- 8Ω and 70V/100V compatible

### Technical specifications

Type of speaker	2-way outdoor speaker
Speaker drivers	8" (20cm) Midbass with Iris IP cone 1" (2.5cm) Aluminium 'M'-shaped tweeter
Bandwidth	45Hz - 28kHz
Impedance	8Ω
Minimal impedance	5.2Ω at 180Hz
Sensitivity	89dB
Power at 8Ω	75W RMS - 150W Peak
Power at 100V	50W
Recommended amp power 8Ω	20W - 150W
Maximum power (70/100V)	80W (40W RMS)
Temperature tolerance	-20° / 65°
IP rating	IP55
Dimensions (WxDxH)	11 <sup>3/8"</sup> x 17 <sup>3/8"</sup> x 17 <sup>3/8"</sup> (29x44x44cm)
Weight	14.3lbs (6.5kg)



## Directionality measurements

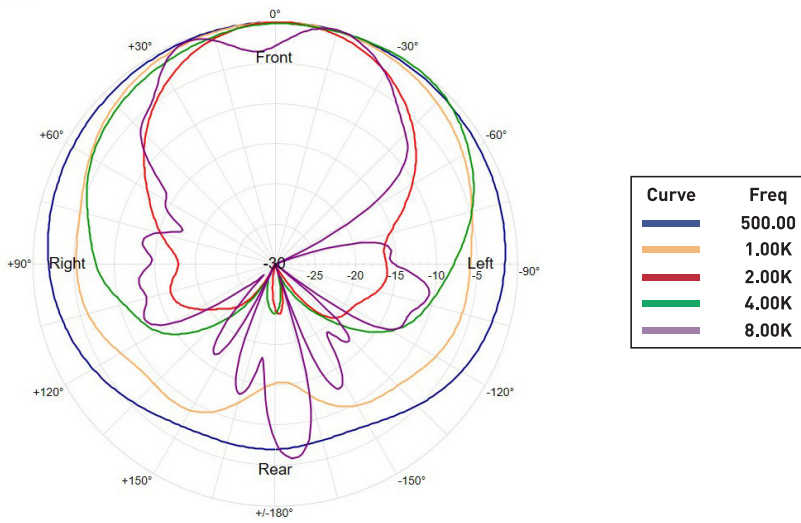

## Frequency response

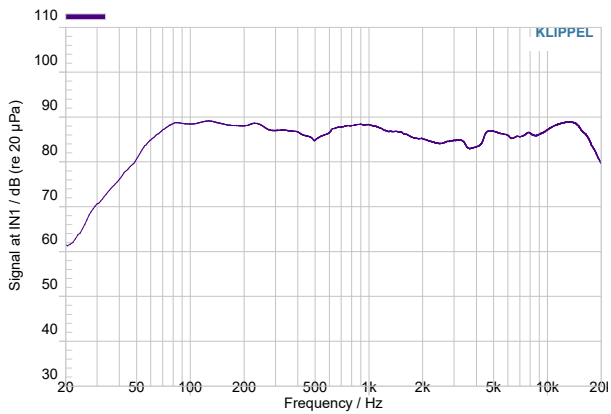

## Levels calculation table

Nominal sensitivity	89dB		
Power/Distance	1m	2m	5m
1W (2.83V)	89dB	83dB	75dB
20W (12.6V)	102dB	96dB	88dB
50W (20V)	106dB	100dB	92dB
100W (28.3V)	109dB	103dB	95dB

Summary	125Hz	250Hz	500Hz	1kHz	2kHz	4kHz	8kHz
NPA (2.83V/1m)(dB)	91	90	92	89	88	88	88
Aperture angle at -6dB	180°	180°	180°	-60°/+180°	-0°/+180°	-20°/+180°	-20°/+60°

*Regards sur*

 **FOCAL**

*At a glance*

## LE SON FOCAL

Vous venez d'acquérir un produit Focal : nous vous en remercions et vous souhaitons la bienvenue dans notre univers de musique et d'émotions. Innovation, tradition, performance et plaisir sont nos valeurs. Où que vous soyez, notre unique objectif est de vous offrir un son d'exception.

---

## THE FOCAL SOUND

You have just purchased a Focal product. We would like to thank you and welcome you to our world, a world of music and emotions. Our key values are innovation, tradition, performance and pleasure. Wherever you are, our only aim is to bring you exceptional sound from our solutions.

## LES COLLECTIONS FOCAL

Mêlant performances et design, les collections Focal sont un éveil aux émotions à travers la qualité ultime d'écoute qu'elles offrent. Et ce, partout: à la maison avec des enceintes acoustiques et intégrées, des systèmes Home Cinéma et des casques ouverts ; en déplacement avec des casques fermés et des kits automobiles ; en studio avec des moniteurs pour les professionnels ; et même en mer avec des solutions dédiées aux yachts.

---

## FOCAL COLLECTIONS

Combining performance and design, Focal's collections are a revelation, awakening the emotions through a supreme listening experience. And it doesn't matter where you are. At home with traditional and in-wall/in-ceiling loudspeakers, Home Cinema systems and open-back headphones; on the go with closed-back headphones and in-car kits; in the studio with professional monitors; and even at sea with specialist yacht solutions.



Home Collection



Motorities Collection



Professional Collection



## INNOVATION

Nos produits se démarquent par leurs technologies brevetées exclusives - vous ne les trouverez nulle part ailleurs -, mais aussi par la façon dont ils ont été pensés et conçus par nos ingénieurs acousticiens. Dans nos ateliers se côtoient réalisations artisanales et techniques de pointe au service de l'audio. Nous cultivons la rigueur, l'inventivité et la précision qui nous mènent à l'excellence.

---

## INNOVATION

Our products stand apart for their exclusive patented technologies - you won't find them anywhere else - as well as for the way in which they have been designed and created by our sound engineers. Our workshops are places where handcrafted creations sit alongside cutting-edge techniques, all in the name of audio. We cultivate fine-tuning and precision, which is what makes us excellent.

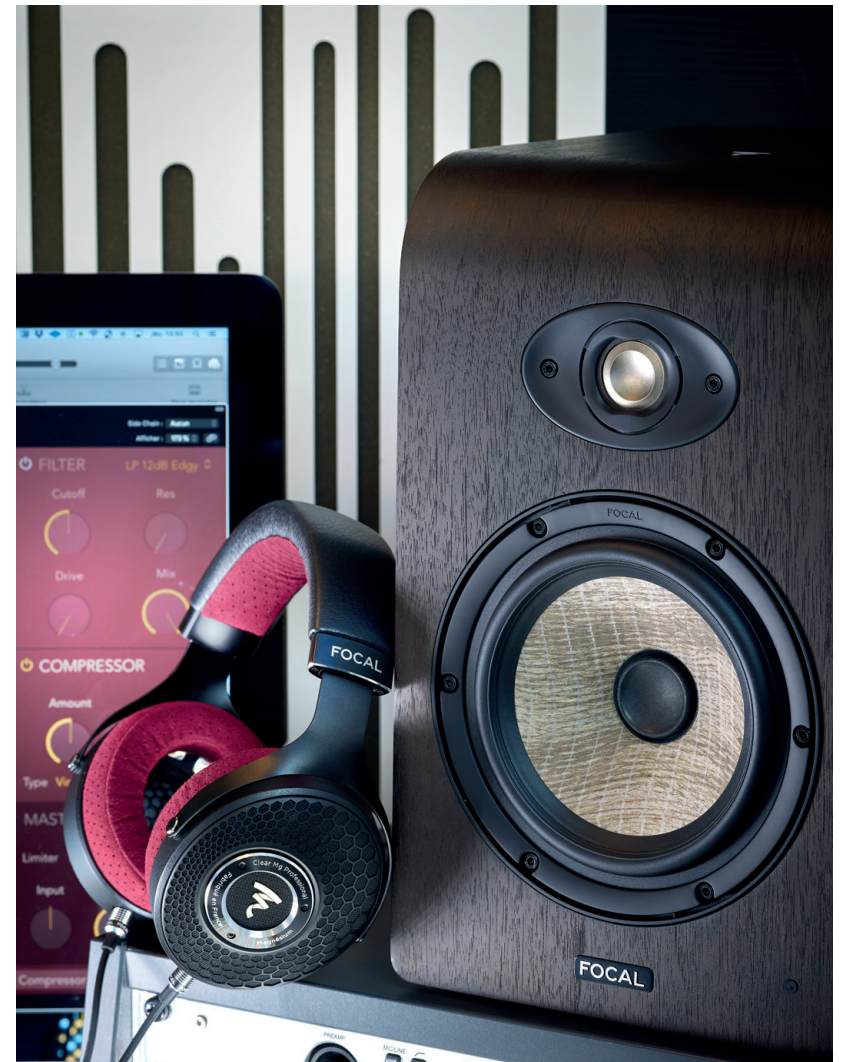

## EXCELLENCE

Réaliser les meilleures solutions pour offrir une expérience d'écoute absolue ; telle est la singularité de notre offre. Nous vous proposons un produit uniquement si nous sommes persuadés qu'il sera une référence dans sa catégorie. Notre savoir-faire en acoustique, associé à la maîtrise de notre fabrication, nous permet de présenter des produits uniques.

---

## EXCELLENCE

Our distinction is to create the very best solutions that deliver the ultimate listening experience. We will only offer you a product if we are convinced that it will be the gold standard in its category. Our expertise in acoustics combined with complete control over our manufacturing process is what enables us to present unique products.



## MANUFACTURÉ EN FRANCE

Depuis 1979, l'histoire de Focal s'écrit chaque jour avec des hommes et des femmes aux savoir-faire uniques. Nous sommes fiers de fabriquer nos produits d'exception dans nos ateliers de production à Saint-Étienne et d'ébénisterie à Bourbon-Lancy. Nous honorons chaque jour cet héritage singulier qui nous vaut aujourd'hui de compter parmi les Entreprises du Patrimoine Vivant français et d'être reconnus mondialement.

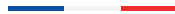

## HANDCRAFTED IN FRANCE

Founded in 1979, Focal continues to write its own history each day, driven by men and women whom possess unique know-how. We are proud to manufacture exceptional products in our production workshops in Saint-Étienne and cabinetry workshops in Bourbon-Lancy, France. Every day we honour this exclusive heritage, which has afforded us certification as a French Living Heritage Company and recognition worldwide.



## UTOPIA

Symboles de l'exception Focal, les lignes Utopia incarnent « l'impossible rendu possible ». L'histoire est née en 1995, avec Grande Utopia. Pari technologique, concentré d'innovations et démesure esthétique, cette enceinte donnera naissance à toute une génération de produits unanimement salués par la presse internationale. Aujourd'hui, l'enceinte acoustique Grande Utopia EM Evo, le casque Utopia, la ligne Utopia M pour l'automobile et les enceintes intégrées 1000 Series Utopia incarnent plus que tout l'excellence Focal.

---

## UTOPIA

Symbolic of Focal exceptionalism, our Utopia lines embody 'the impossible made possible'. The story began in 1995, with Grande Utopia. A technological gamble, packed with innovations and with audacious styling, this loudspeaker would give rise to an entire generation of products universally acclaimed by the international press. Today, the Grande Utopia EM Evo hi-fi loudspeakers, Utopia headphones, the Utopia M line for vehicles and the 1000 Series Utopia integrated loudspeakers embody Focal excellence.



# VERVENT AUDIO

Afin de vous offrir une expérience totale, Focal et Naim Audio - marque anglaise leader en électronique de pointe - sont unies au sein du groupe Vervent Audio. Nous travaillons main dans la main pour vous proposer une gamme de produits complémentaires. Nos solutions audio incarnent ce mélange de haute technologie et d'artisanat de luxe. Au cours des dernières années, nous avons accompli ensemble ce que nos marques n'auraient jamais pu réaliser séparément.

---

# VERVENT AUDIO

Focal and Naim Audio — renowned, cutting-edge English hi-fi brand — have been working together as part of the Vervent Audio group to offer you a complete experience. We work hand-in-hand to offer you a range of complementary products. Our audio solutions perfectly embody this combination of high technology and luxury craftsmanship. Together, we have accomplished things in recent years that our brands would never have been able to achieve on their own.

