

SPEAKMAN®

SM-7410

Installation, Operation & Maintenance Instructions

CASPIAN™ COLLECTION COMBINATION SERIES

DESCRIPTION

Speakman Caspian™ Collection Combination SM-7410 includes: Shower Valve Trim (CPT-7400), Shower Arm with Wall Flange (S-2500) and Multi Function Shower Head (S-3014). This combination does include the Shower Valve.

PB-DV

This combination comes with the following Speakman Sentinel Mark II® Pressure Balance Diverter Shower Valve

CPV-PB-DV: Pressure Balance Diverter Shower Valve
Sweat & Thread Connections

SPECIFICATIONS

CPV-PB-DV SENTINEL MARK II® PRESSURE BALANCE DIVERTER SHOWER VALVE:
COMPLIANCE: ASME A112.18.1 / CSA B125.1 Certified / ASSE 1016 Certified

CPT-7400 CASPIAN™ COLLECTION SHOWER VALVE TRIM:
COMPLIANCE: ASME A112.18.1 / CSA B125.1 Standard

S-2500 CASPIAN™ COLLECTION SHOWER ARM WITH WALL FLANGE:
CONNECTIONS: ½" NPT Male Inlet & Outlet

S-3014 CASPIAN™ COLLECTION MULTI FUNCTION SHOWER HEAD:
CONNECTIONS: ½" NPT Female Inlet
FLOW RATE: 2.5 gpm (9.5 L/min)
COMPLIANCE: ASME A112.18.1 / CSA B125.1 Standard

INSTRUCTIONS

See individual products for installation of the components and warranty information.

SPEAKMAN®

Phone: 800-537-2107 Fax: 800-977-2747
01/03/19 www.speakman.com 92C-SM-7410-01

ROUGH-IN

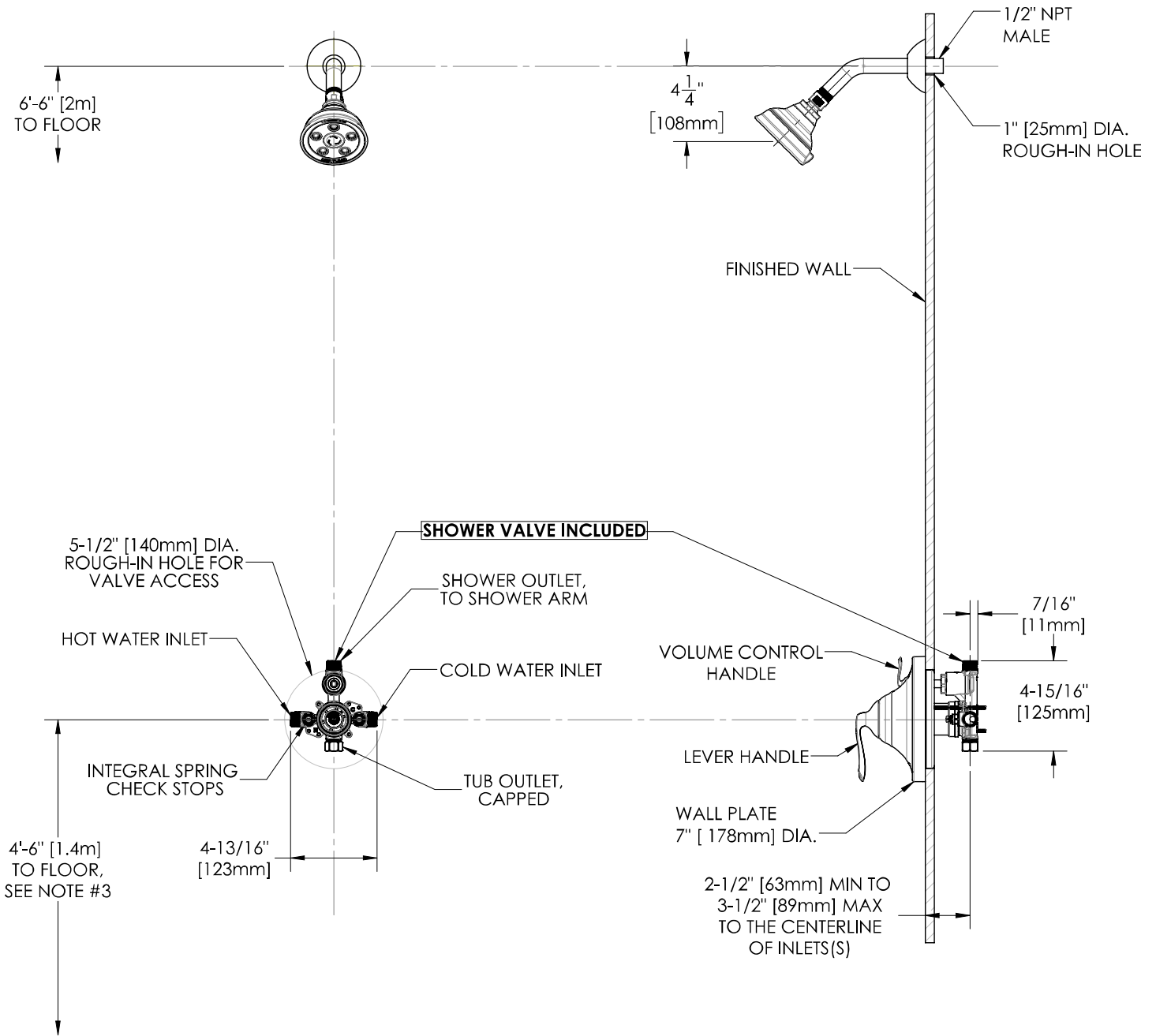

NOTES:

1. ALL DIMENSIONS ARE IN INCHES [MILLIMETERS] UNLESS OTHERWISE SPECIFIED AND ARE SUBJECT TO CHANGE WITHOUT NOTICE.
2. ALL INLETS AND OUTLETS ARE 1/2" FEMALE COPPER SWEAT AND 1/2" MALE NPT UNLESS OTHERWISE SPECIFIED.
3. FOR ADA MOUNTING LOCATIONS CONSULT ADAAG, ANSI A117.1, OR STATE REGULATIONS.

SPEAKMAN®

INSTRUCTIONS FOR MODELS

CPV-PB
CPV-PB-DV

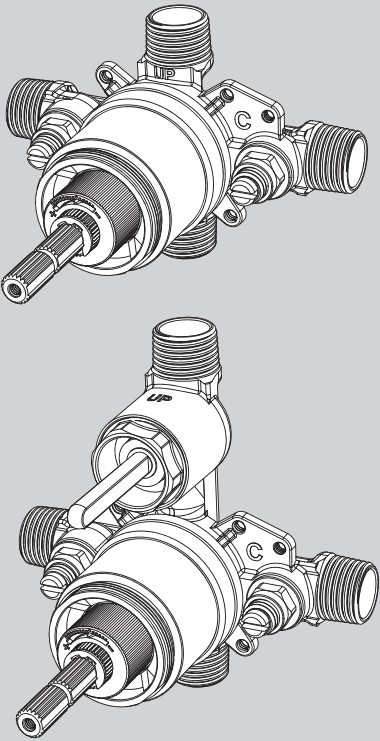

NEED HELP?

For additional assistance or service please contact:

SPEAKMAN® Company
400 Anchor Mill Road
New Castle, DE 19720

800-537-2107

customerservice@speakman.com

www.speakman.com

92-CPV-PB-02

TOOLS AND SUPPLIES

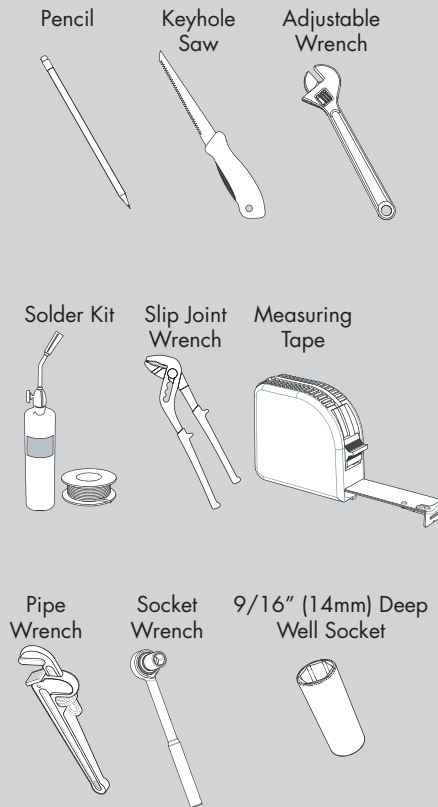

HELPFUL TOOLS & SUPPLIES:

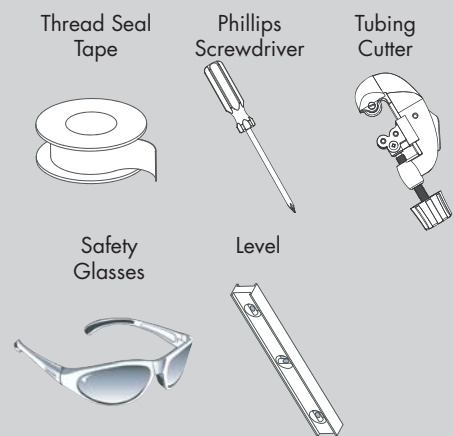

IMPORTANT

- Be sure to read instructions thoroughly before beginning installation.
- Be sure to have properly adjusted the Temperature Limiting Stop (TLS) as outlined in this Installation Manual.
- Inspect all connections after installation of valve.
- This valve has an operating range of 20-80 psi.
- This valve is designed to be used in conjunction with a shower-head rated at 1.75 gpm (6.6 L/min) or higher flow rate.
- **NOTE:** This installation manual covers several models of valves. While the appearance of your valve may differ from those shown, the installation method is the same.
- Maximum water pressure: 125 psi static; minimum water pressure: 20 psi flowing; minimum cold supply temperature: 40 °F; maximum hot supply temperature: 160 °F; minimum hot supply temperature: 5 °F above set point.

SAFETY TIPS

Cover your drain to prevent loss of parts. Be sure to wear eye protection while cutting pipe.

MAINTENANCE

Your new Shower/Bath Valve is designed for years of trouble-free performance. Keep it looking new by cleaning it periodically with a soft cloth. The use of harsh chemicals and abrasives on any of the Speakman custom finish products may damage the finish and void the product warranty. Please be sure to only use approved cleaners. Please contact Speakman for any clarification of acceptable cleaners.

This type of valve must be cleaned and maintained on a regular basis. Periodic maintenance should be performed at least every 12 months or after any changes have been made to the building's plumbing system. This maintenance should include removing and cleaning the spring check stop components. Make sure the stop poppet in each stop moves freely. Valves that are installed outdoors should be winterized by removing all of the internal parts and removing any standing water from the valve. Quarterly the maximum hot temperature setting (TLS) should be checked and adjusted accordingly.

WARRANTY

Warranty information can be found at: www.speakman.com

1 Remove the two Screws with a Philips Head Screwdriver then slide the Rough-In Template off the Valve.

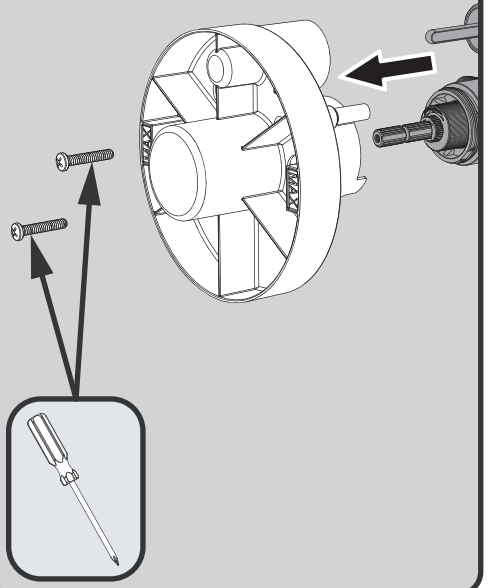

2 Referencing the supplied rough-in dimensions (located at the end of this manual), determine the preferred location of Valve. Align the supplied Rough-In Template with this location and trace outline of Template onto wall. Using a Keyhole Saw or similar tool, cut along traced line and remove this section of wall.

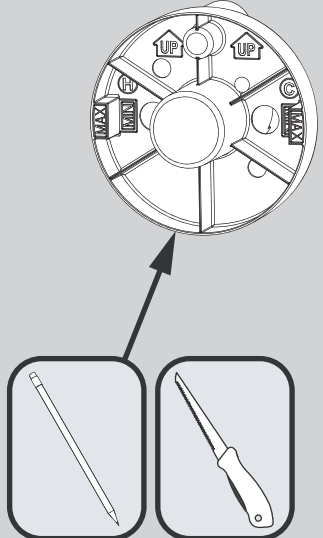

3 Shut off the water supply to the Tub and Shower. Verify that the hole sizes and positions in the wall are correct:

- The shower and tub spout outlet holes should be 1" diameter.
- To determine the Valve mounting depth, see **STEP 4**.
- The recommended Valve depth to the finished wall is 2½" minimum to 3½" maximum. Position the Valve Body **1** correctly in the wall with the "UP" pointing up. The 1'-9" minimum from the Valve Body to the Tub Spout is required for proper operation.

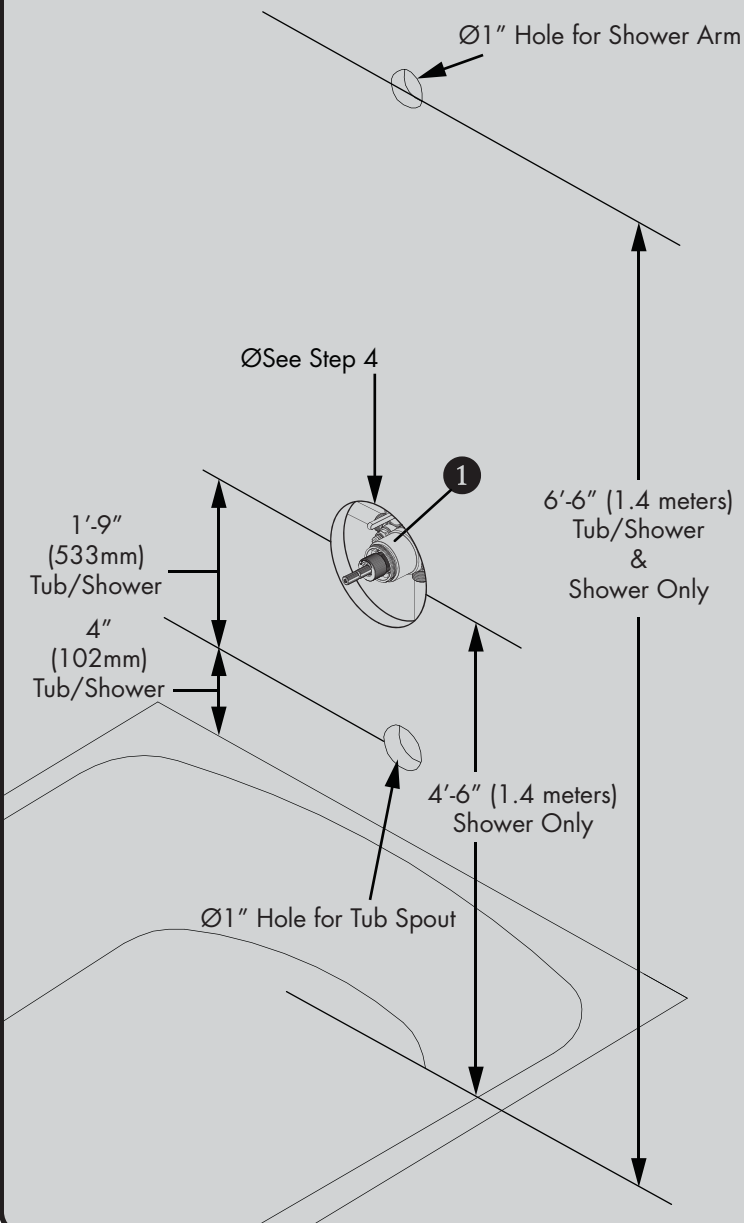

4 Install the Rough-In Template over the Shower Valve being sure the Rough-In Template sits flush against Valve Body. Following the rough-in dimensions for your model of valve (located at the end of this manual) as well as the markings on the supplied Rough-In Template, install valve at proper depth. The distance from the centerline of the inlet/outlet ports of the Valve Assembly to the finished wall **MUST** be between 2½" - 3½". See images below for reference.

MINIMUM MOUNTING DEPTH

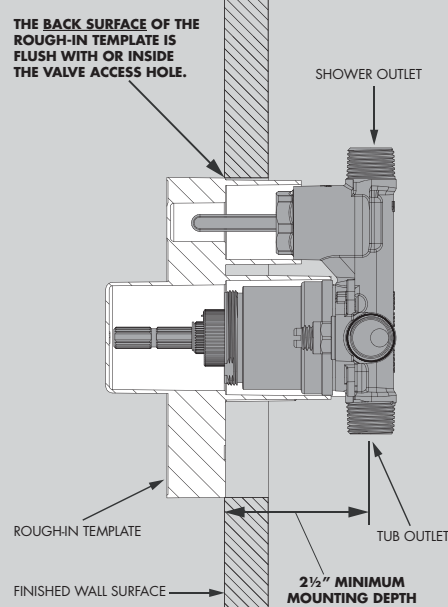

MAXIMUM MOUNTING DEPTH

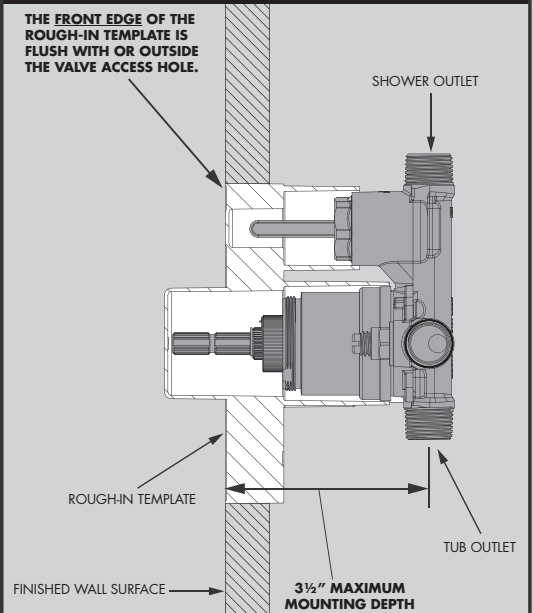

5 If your installation is for a shower only, apply Thread Seal Tape in a clockwise direction to the Tub Outlet Port **1** and install the included Plug Cap. Wrench tighten. If you are performing a pipe fitting installation, apply Thread Seal Tape around the pipe threads in a clockwise direction.

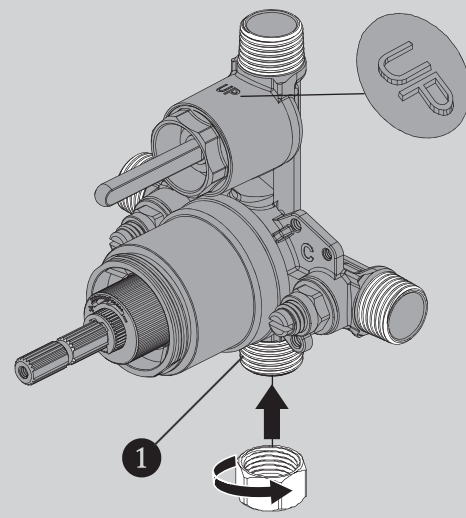
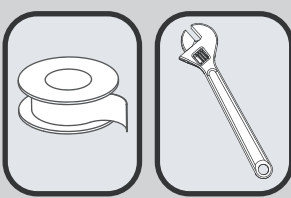

6 PIPE FITTING INSTALLATION

Connect the HOT and COLD Water Supply Lines **2** (not included), the Shower Outlet Pipe **3** (not included), and Tub Outlet Pipe **4** (not included), by threading them into the Valve Body **1** in a clockwise direction. Tighten the pipes to the Valve Body **1** with a Pipe Wrench. Connect the Pipe Elbows **5** (not included), to the end of the shower outlet and tub outlet pipes. If performing a shower only installation, install Plug Cap **6** in place of tub outlet piping, as shown in **STEP 5**.

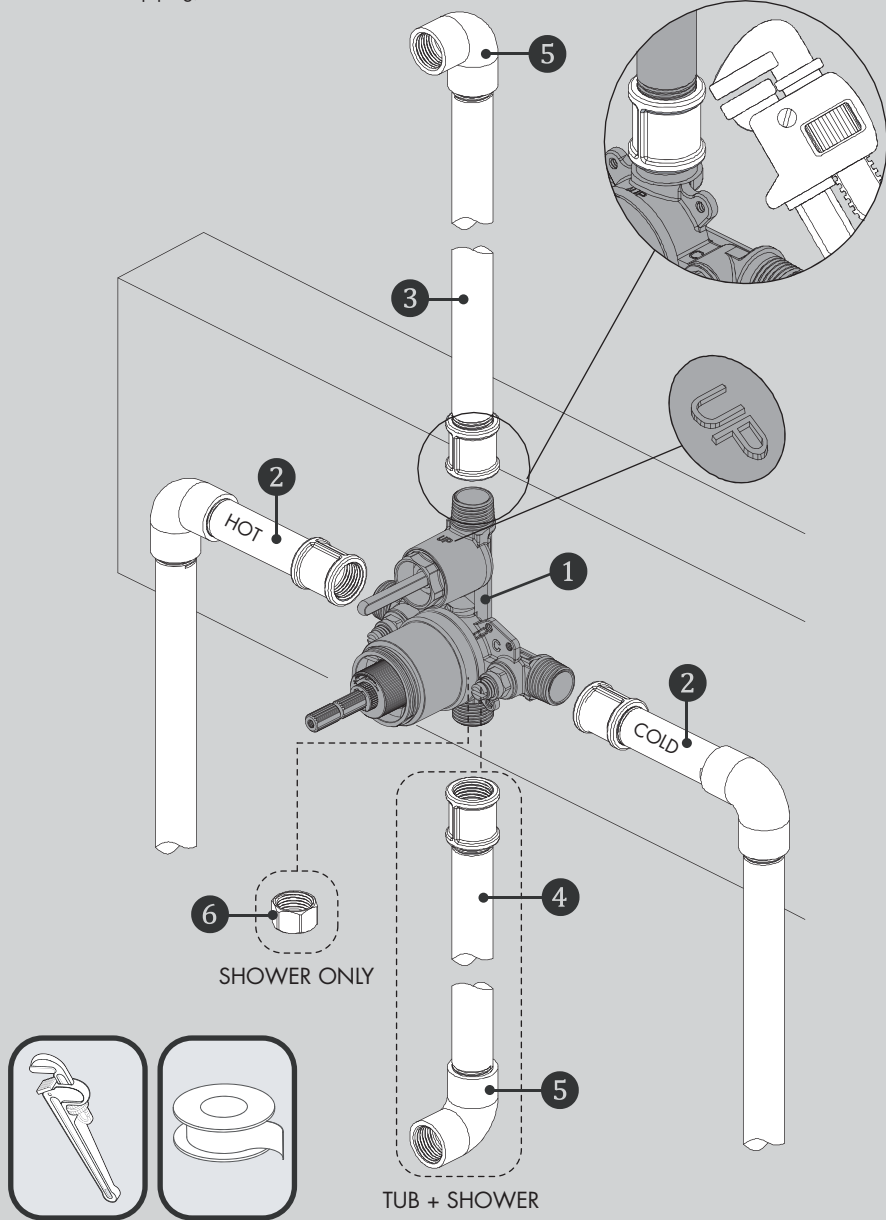

NOTE: The HOT water supply lines go into the H inlet, and the COLD water supply lines go into the C inlet. Do not use PEX or CPVC between the valve and spout.

7 COPPER SWEAT INSTALLATION

When performing a Copper Sweat installation, it is recommended that you remove the Valve Cartridge **4**, Integral Stops **5**, and Diverter Cartridge **2** (where applicable) to prevent damage during soldering. Use a Slip Joint Wrench to unthread and remove the Bonnet **3**. Then remove Valve Cartridge **4**, from Valve Body **6**. Unthread and remove the Integral Stops **5** using a Socket Wrench equipped with a 9/16" (14mm) Deep Well Socket. If your Shower Valve is equipped with an Integral Diverter, remove the Diverter Retaining Nut **1** using an Adjustable Wrench. Remove Diverter Cartridge **2** to prevent damage during soldering.

After soldering (**STEP 8**) is completed, reinstall the Valve Cartridge **4**, making sure that the mounting posts are aligned and engaged to the corresponding holes in the Valve Body **6**, with the "H" marking to the left side as shown below. Slide Bonnet **3** over the Valve Cartridge **4** and thread onto the Valve Body **6**. Tighten securely with Slip Joint Wrench on the machined flats of the Bonnet **3**. Final torque should be 88-106 in*lb. Take care to not over tighten connection or damage may occur. Reinstall the Integral Stops **5** using a Socket Wrench equipped with a 9/16" (14mm) Deep Well Socket. Final torque should be 70-106 in*lb. If your Shower Valve is equipped with an Integral Diverter, reinstall the Diverter Cartridge **2** taking care to align mounting posts of Cartridge with the corresponding holes in the Diverter Valve Body. Install Diverter Retaining Nut **1** and tighten with an Adjustable Wrench. Final torque should be 35-53 in*lb. Take care to not over-tighten connections.

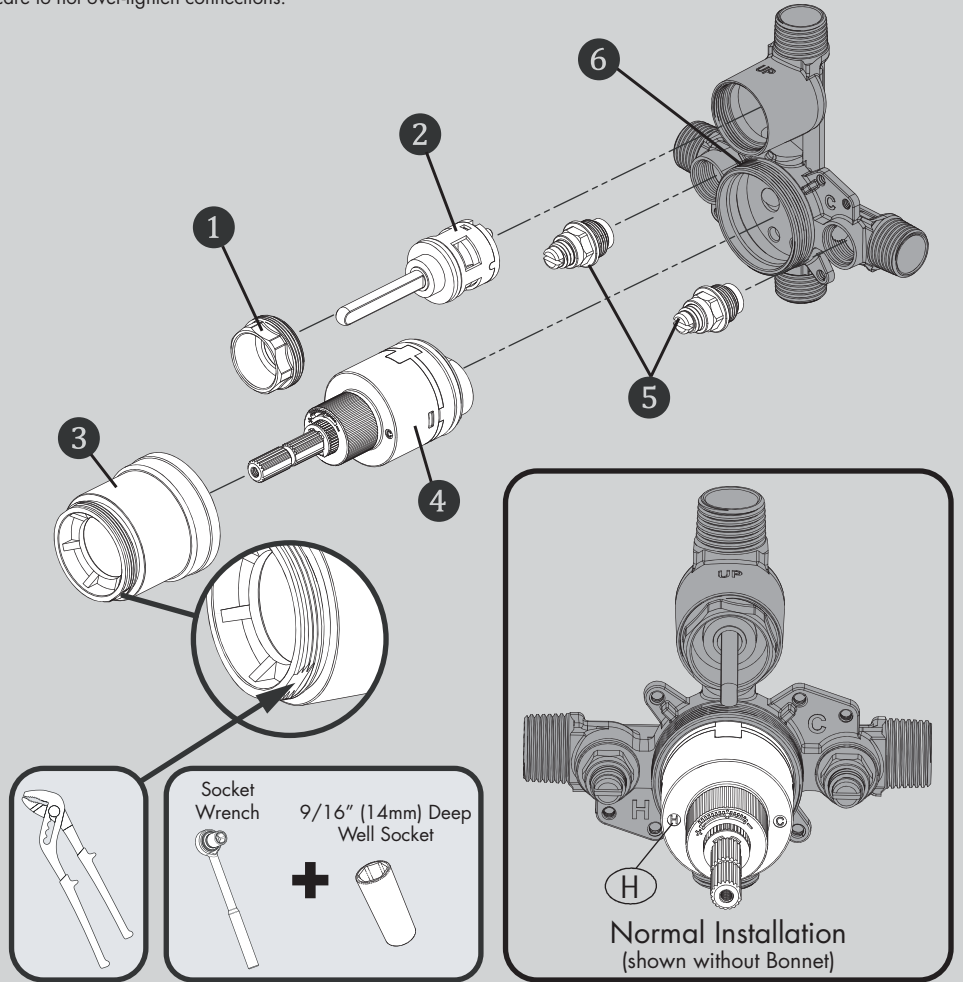

NOTE: Never install the valve body upside down!

8 COPPER SWEAT FITTING INSTALLATION

Connect the HOT and COLD Water Supply Lines **2** (not included), the Shower Outlet Pipe **3** (not included), and Tub Outlet Pipe **4** (not included), by soldering them into the Valve Body **1**. Connect the Pipe Elbows **5** (not included), to the end of the shower outlet and tub outlet pipes. If performing a shower only installation, install Plug Cap **6** in place of tub outlet piping, as shown in **STEP 5**. Verify that all connections are soldered. Reassemble Valve components as outlined in **STEP 7**.

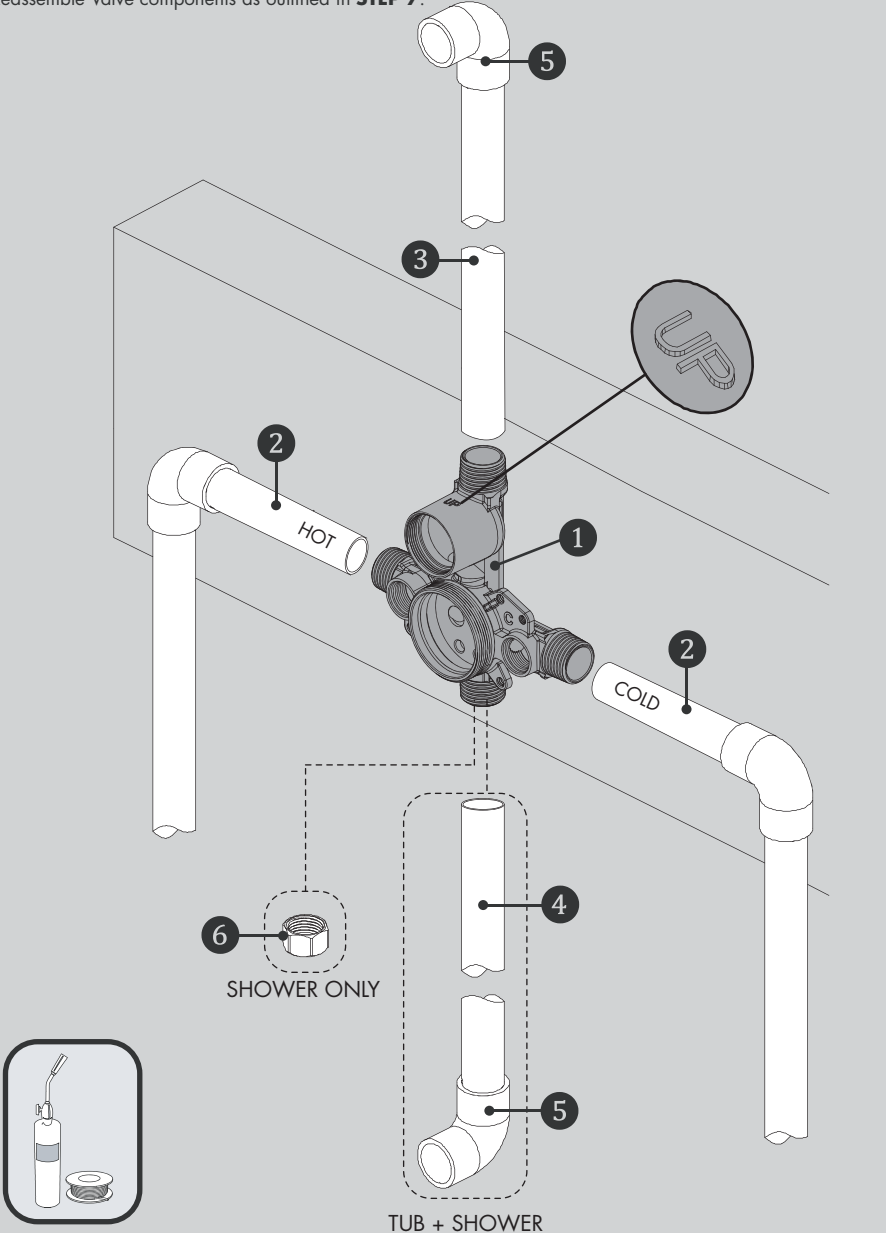

NOTE: The HOT water supply lines go into the H inlet, and the COLD water supply lines go into the C inlet. Do not use PEX or CPVC between the valve and spout.

9 BACK-TO-BACK INSTALLATION

Your Shower Valve has the ability to be mounted back-to-back with another Valve in a shared space. This means the HOT and COLD inlets may be reversed. Please see the following steps to adapt your valve for back-to-back mounting or reversed inlet supplies.

If you are **NOT** making a reverse or back-to-back installation, skip this step, and continue with **STEP 10**. If the HOT and COLD water supplies are reversed (HOT on right and COLD on left), disassemble Valve Cartridge as outlined in **STEP 7**. Rotate Valve Cartridge **2** 180° so "H" appears on the right. Install the Valve Cartridge **2** making sure that the mounting posts are aligned and engaged to the corresponding holes in the Valve Body **3**. Slide Bonnet **1** over the Cartridge and thread onto the body. Tighten securely with Slip Joint Wrench on the machined flats of the Bonnet **1**. Final torque should be 88-106 in*lb. Take care to not over tighten connection or damage may occur.

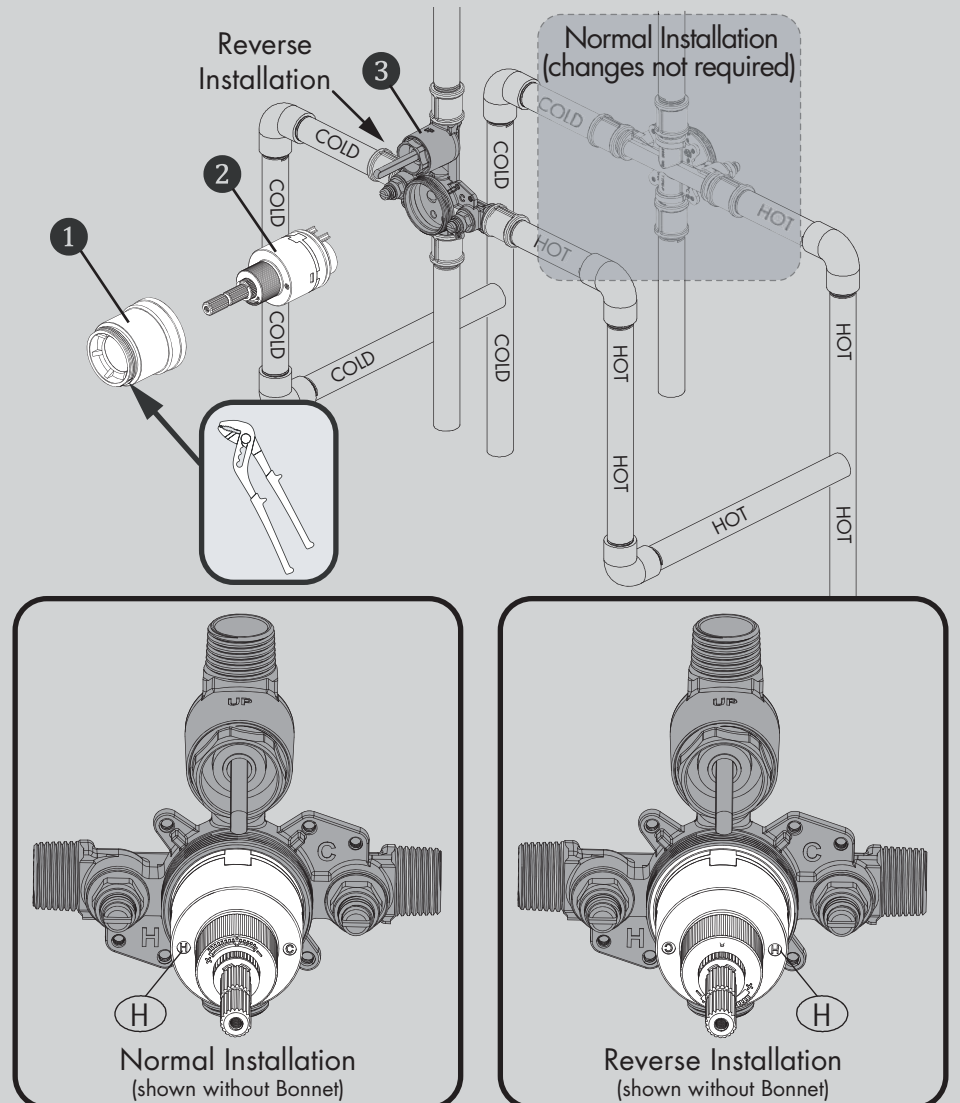

NOTE: Never install the valve body upside down!

10 FLUSHING THE WATER OUTLETS AND CHECKING FOR LEAKS

Place the Handle ① on the Valve Cartridge Spindle ② and turn the Handle ① clockwise to the full on mixed position. Turn on the HOT and COLD water supply lines and allow the water to flow from the outlets for one minute, or until all foreign matter has been flushed out. Check for leaks. Shut off the water at the Valve and supply lines. Remove the Handle ①.

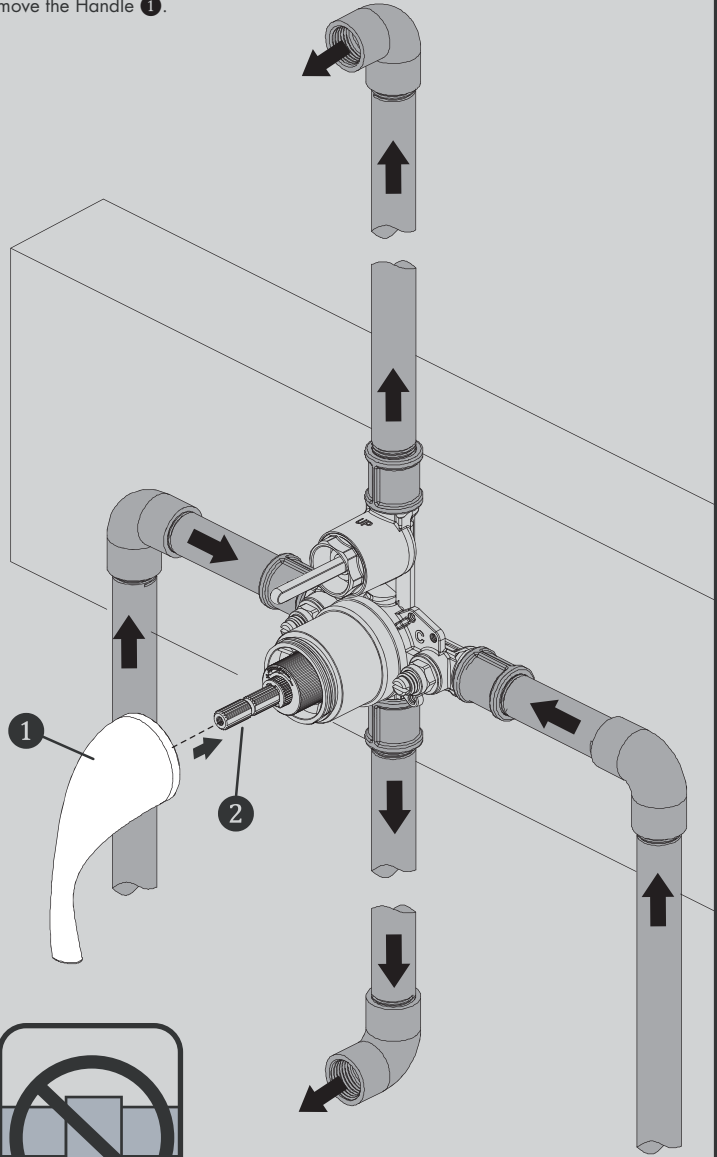

11 ADJUSTING THE TEMPERATURE LIMIT STOP (TLS)

The maximum outlet temperature setting adjustment (Temperature Limit Stop (TLS)) of the Valve has been factory set at 110 °F. To adjust the limit of the maximum outlet temperature the Valve delivers, adjust the Valve's temperature limit stop (TLS) collar by following the steps below.

- With the water supplies "On" and the Valve in the "Off" position, remove the (RED) TLS adjustment collar ① from the Cartridge ②.

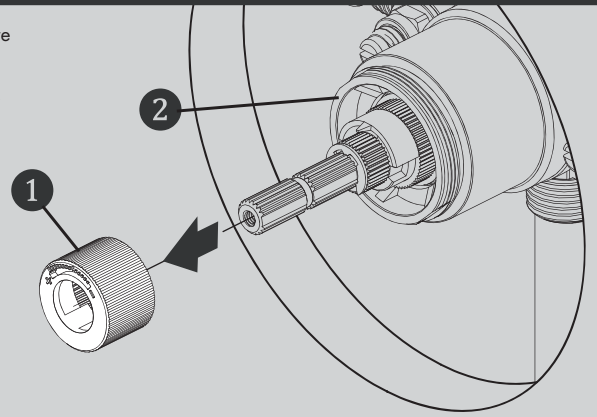

ADJUSTING THE TEMPERATURE LIMITER

• **For Colder setting**, adjust the Temperature Limiting Collar in a counter-clockwise direction and slide it back to the splined section of the Cartridge until fully seated. Rotate the Valve Spindle clockwise to check if desired outlet temperature is achieved. If not, repeat the procedure.

• **For Hotter setting**, adjust the Temperature Limiting Collar in a clockwise direction and slide it back to the splined section of the Cartridge until fully seated. Rotate the Valve Spindle clockwise to check if desired outlet temperature is achieved. If not, repeat the procedure.

- Once desired outlet temperature is achieved, rotate the spindle counter-clockwise to the "Off" position.

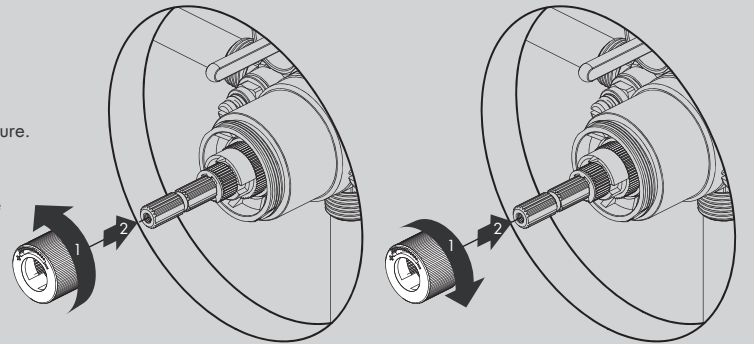

FOR COLDER WATER

FOR HOTTER WATER

NOTE: A thermometer can be held at the Valve outlet to aid in either checking the existing factory setting or reaching the desired outlet temperature.

12 Reinstall Rough-In Template over Valve to protect it during final wall preparation. Secure into position with the included screws.

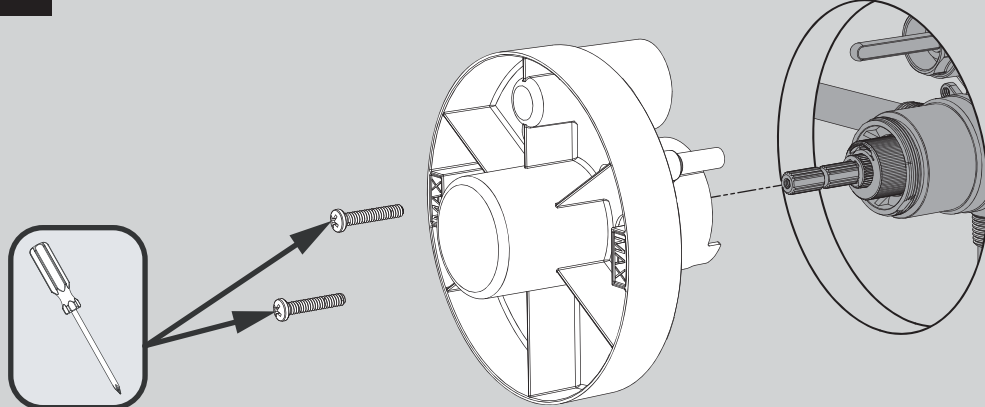

CPV-PB / CPV-PB-DV SERVICE INSTRUCTIONS

Service Instructions

Caution- Any repair or servicing of the Valve may effect the maximum outlet temperature setting of the Valve. After working on the Valve, make sure the maximum outlet temperature is set to the recommended setting of 110 °F.

Pressure Balance Cartridge Removal

- 1) Remove Trim from Valve. Close the Integral Stops of the Valve by turning the Stop Spindles clockwise.
- 2) With the Valve in the "OFF" position, remove the Bonnet by unthreading with a Slip Joint Wrench.
- 3) If necessary, remove the Cartridge from the Valve Body by pulling on the Valve spindle of the Cartridge. Verify that the Lower Cartridge Seal is in place within the Valve Cartridge, and not within the Valve Body.
- 4) Replace the Pressure Balance Cartridge if necessary. When replacing the Pressure Balance Cartridge, verify that the Lower Cartridge Seal is properly installed in the recess on the bottom of the Cartridge. This Lower Cartridge Seal is positioned over the HOT & COLD inlet waterways of the Valve Body.
- 5) Reassemble the Bonnet by threading it into the Valve Body with a Slip Joint Wrench. Final torque should be 88-106 in*lb. **Important-** Adjust the Valve's maximum outlet temperature to the recommended setting of 110 °F. See Temperature Limit Stop adjustment steps within this document.
- 6) Open the Integral Stops of the Valve by turning the Stop Spindles counter-clockwise. Check Valve for leaks.
- 7) Reassemble the Trim parts.

Spring Check Stop Parts Removal

- 1) Remove Trim from Valve. Shut off HOT and COLD water supply lines to the inlets of the Valve.
- 2) Unscrew the Stop's Retaining Nut using a Socket Wrench equipped with a 9/16" (14mm) Deep Well Socket. Carefully remove the Retaining Nut w/Spindle, Spring, and Poppet assembly. Clean and/or replace the necessary parts. Reassemble the parts, reversing the above procedure. Final torque should be 70-106 in*lb. Repeat procedure on the other Stop.
- 3) Turn on the HOT and COLD water supply lines. Check for leaks.
- 4) Reassemble the Trim Parts.

Diverter Cartridge Removal (if present)

- 1) Remove Trim from Valve. Close the Integral Stops of the Valve by turning the Stop Spindles clockwise.
- 2) Remove the Diverter Retaining Nut using an Adjustable Wrench.
- 3) Remove Diverter Cartridge from Valve Body. Verify that the Lower Cartridge Seal is in place within the Diverter Cartridge, and not within the Valve Body.
- 4) Replace the Diverter Cartridge if necessary. When replacing the Diverter Cartridge, make sure that the mounting posts are aligned and engaged to the corresponding holes of the Valve Body.
- 5) Reassemble the Diverter Retaining Nut using an Adjustable Wrench. Final torque should be 35-53 in*lb.
- 6) Open the Integral Stops of the Valve by turning the Stop Spindles counter-clockwise. Check for leaks.
- 7) Reassemble the Trim Parts.

CPV-PB / CPV-PB-DV REPAIR PARTS

SPEAKMAN®

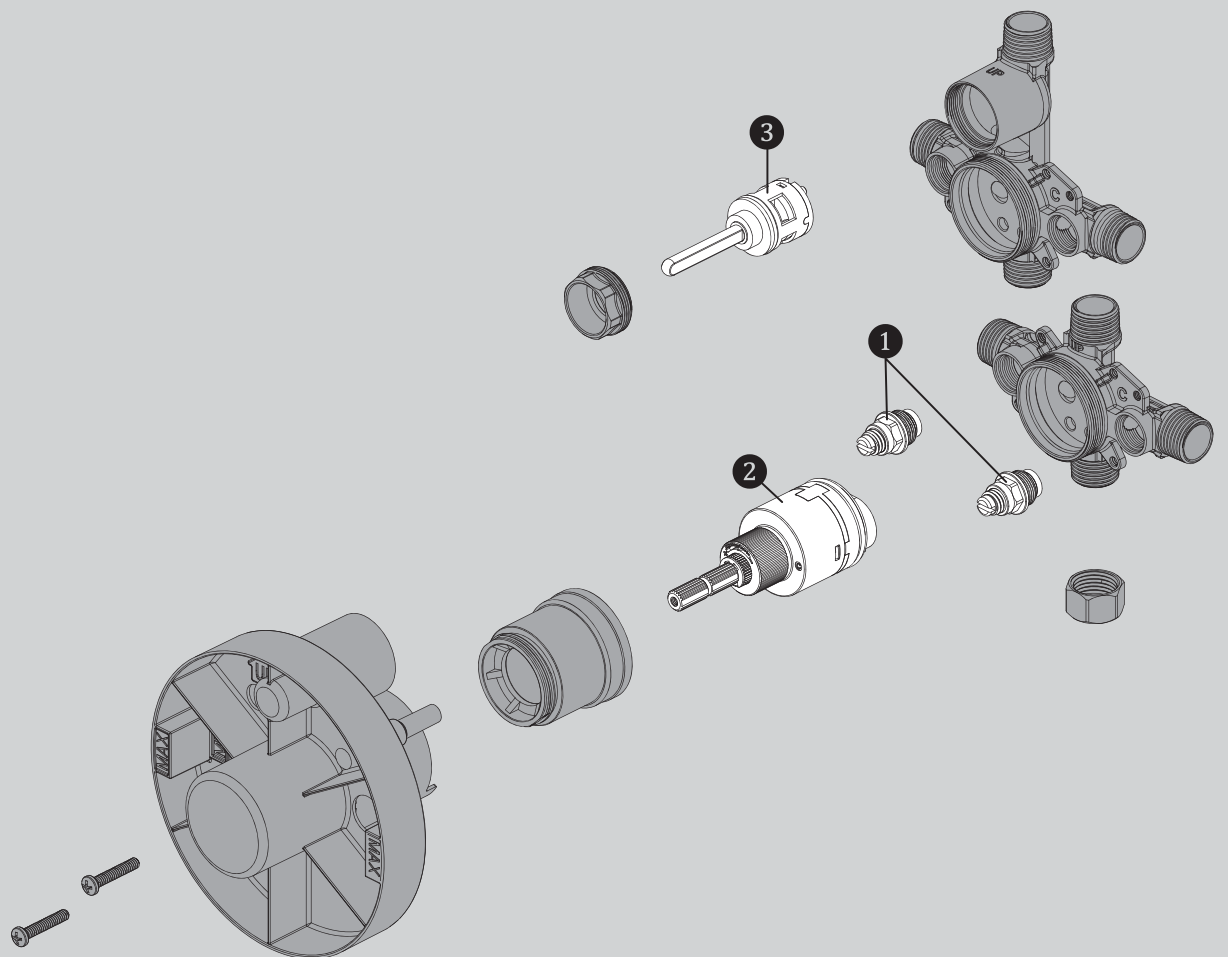

ITEM #	PART #	DESCRIPTION
1	RPG50-21029	CHECK STOP REPAIR KIT
2	RPG05-1124	PRESSURE BALANCE CARTRIDGE
3	RPG05-0897	DIVERTER CARTRIDGE

NOTES:

COMPLIANCE:

ASME A112.18.1/CSA B125.1
 ASSE1016/ASME A112.1016/CSA B125.16

CONNECTIONS:

Hot/Cold Inlets: 1/2" Female Copper Sweat
 1/2" NPT Male

Shower Outlet: 1/2" Female Copper Sweat
 1/2" NPT Male

Tub Outlet: 1/2" Female Copper Sweat
 1/2" NPT Male
 (Cap included for Shower Only Connections)

NOTES:

This valve is designed to be used in conjunction with a shower-head rated at 1.75 gpm (6.6 L/min) or higher flow rate

Contractor to supply necessary inlet connections.

DIMENSIONS SUBJECT TO CHANGE WITHOUT NOTICE. FOR ADA MOUNTING LOCATIONS, CONSULT ADAAG, ANSI A117.1, AND STATE REGULATIONS.

DIMENSIONS SUBJECT TO CHANGE WITHOUT NOTICE.

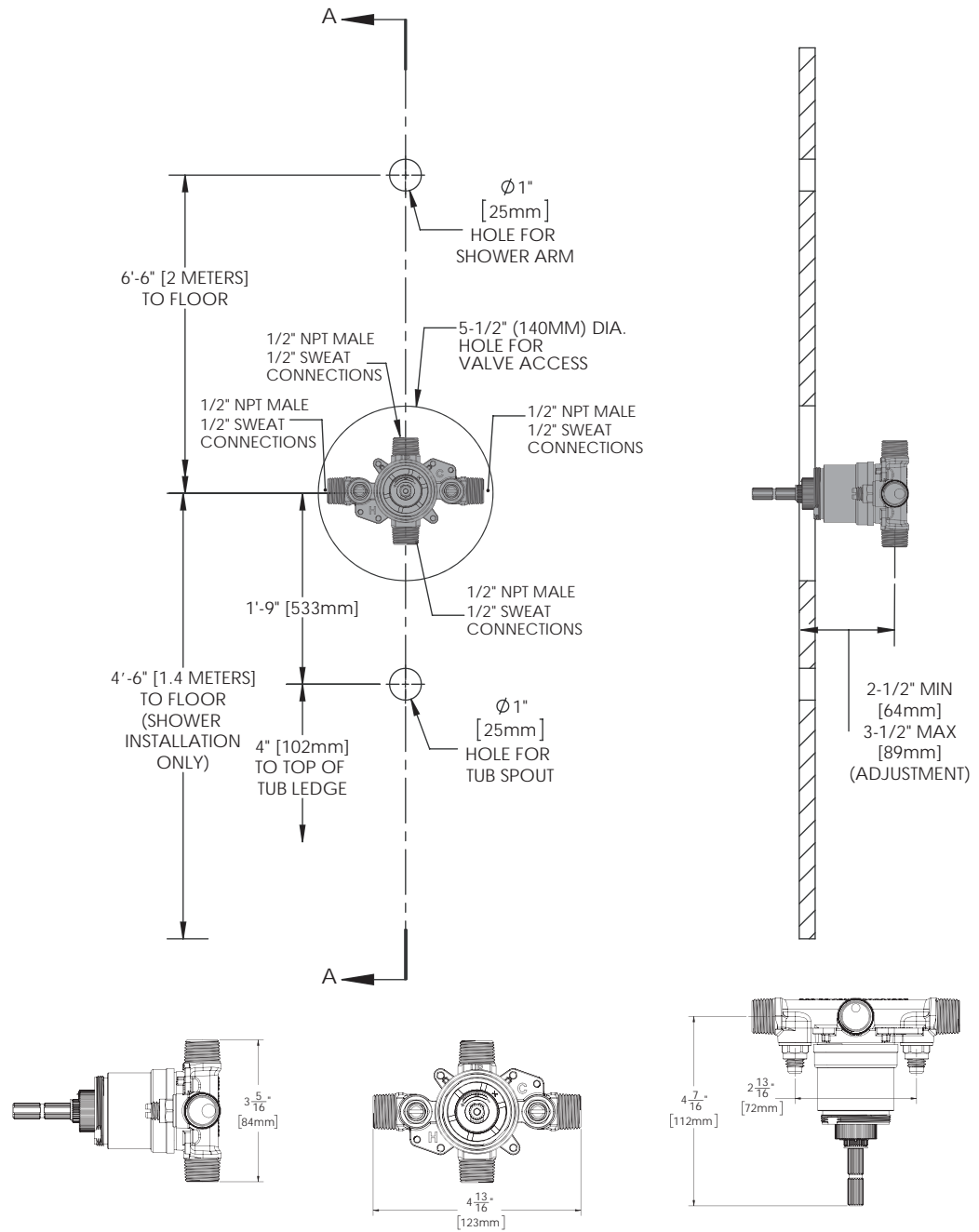

NOTES:

COMPLIANCE:

ASME A112.18.1/CSA B125.1
 ASSE1016/ASME A112.1016/CSA B125.16

CONNECTIONS:

Hot/Cold Inlets: 1/2" Female Copper Sweat
 1/2" NPT Male

Shower Outlet: 1/2" Female Copper Sweat
 1/2" NPT Male

Tub Outlet: 1/2" Female Copper Sweat
 1/2" NPT Male
 (Cap included for Shower Only Connections)

NOTES:

This valve is designed to be used in conjunction with a shower-head rated at 1.75 gpm (6.6 L/min) or higher flow rate

Contractor to supply necessary inlet connections.

DIMENSIONS SUBJECT TO CHANGE WITHOUT NOTICE. FOR ADA MOUNTING LOCATIONS, CONSULT ADAAG, ANSI A117.1, AND STATE REGULATIONS.

DIMENSIONS SUBJECT TO CHANGE WITHOUT NOTICE.

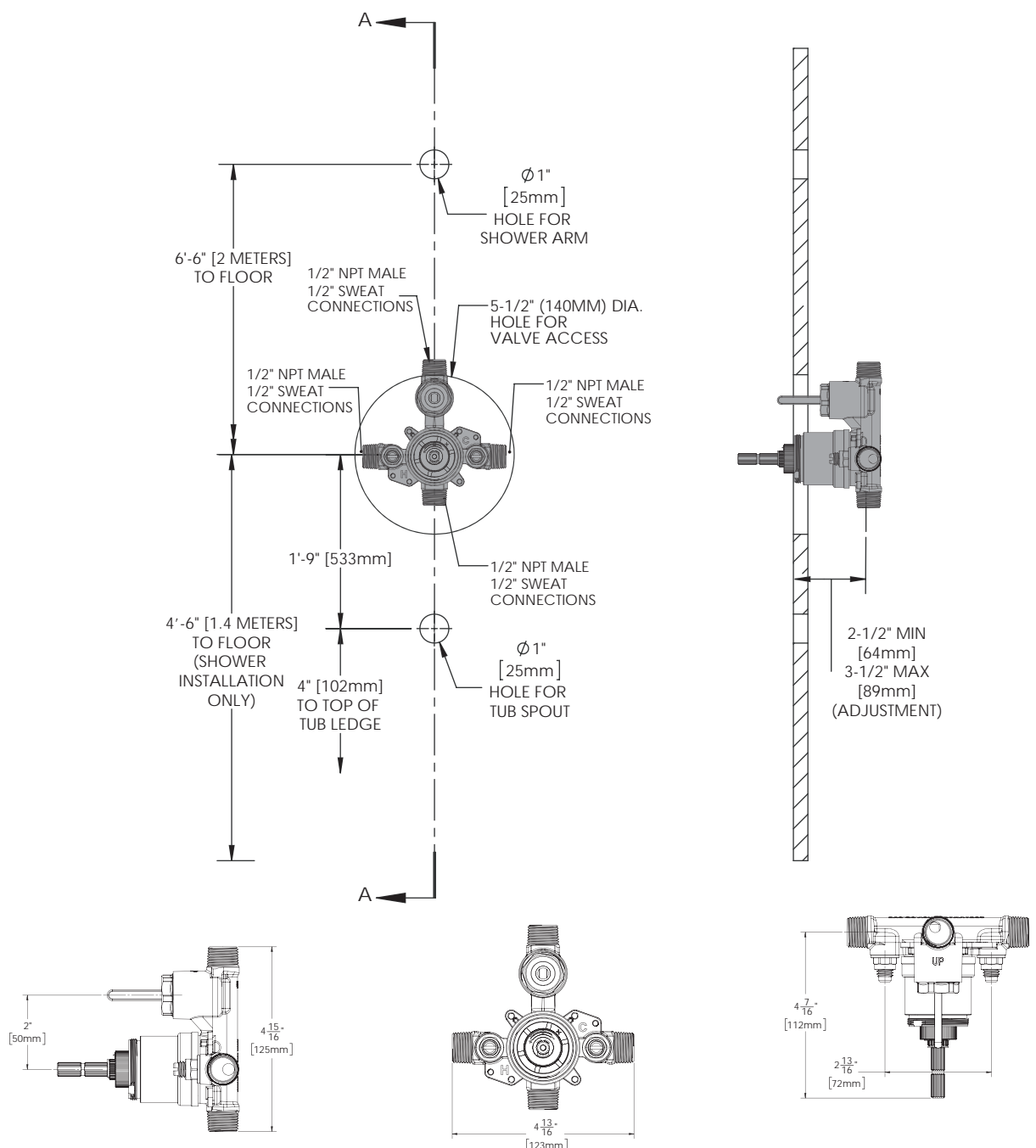

Instructions for Models:

CPT-7400-P
CPT-7400-P-BN
CPT-7400-P-PN

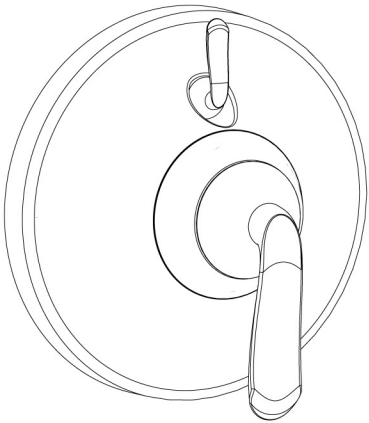

Need Help?

For additional assistance or service call:

SPEAKMAN Company
400 Anchor Mill Road
New Castle, DE 19720

PHONE: 800-537-2107
EMAIL: customerservice@speakmancompany.com
WEB: www.speakmancompany.com

92-3269-R1

What You Need To Know:

Tools:

Required:

*Phillips Screwdriver

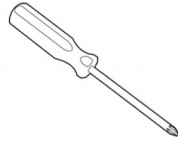

Helpful:

* Tape Measure



Important Notes:

Be sure to read instructions thoroughly before beginning installation. Do not overtighten any connections or damage may occur.

Be sure to have properly adjusted the Temperature Limiting Stop (TLS) as per the Valve Installation Instructions before installing Valve Trim.

Safety Tips:

Cover your drain to prevent loss of parts.

Maintenance:

Your new valve trim is designed for years of trouble-free performance. Keep it looking new by cleaning it periodically with a soft cloth. Avoid abrasive cleaners, steel wool, and harsh chemicals as these will dull the finish and void your warranty.

- 1 Clean wall surface. Place the mounting base (1) on to valve, align mounting holes, and secure with screws (2).

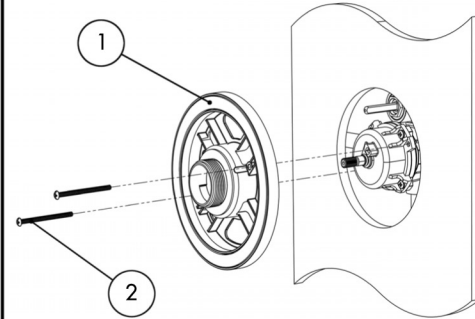

- 2 There are 2 Connectors (3) included to allow for both Shallow and Deep mount applications. Please select Connector appropriate for your installation.

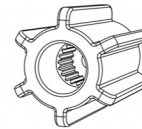

For Shallow Mount Application

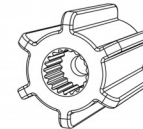
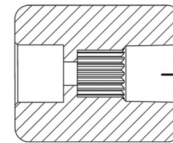

For Deep Mount Application

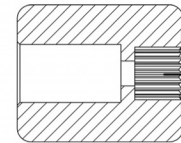

- 3 Confirm that valve is in the "off" position. Place appropriate Connector (3) on spindle of valve making sure to orient the Connector so that one set of splines are in a perfectly vertical position.

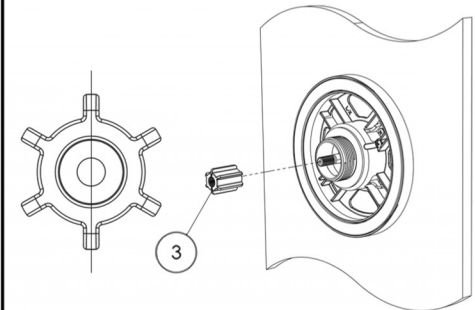

- 4 ***IMPORTANT***
When installed correctly, the Connector (3) should protrude from the Mounting Base inbetween 5/16" and 1". Secure with Screw (4)

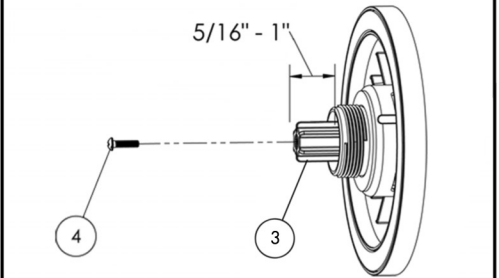

- 5 Place Escutcheon (5) on Mounting Base. Take care to align Diverter Handle assembly (5a) with Diverter Spindle.

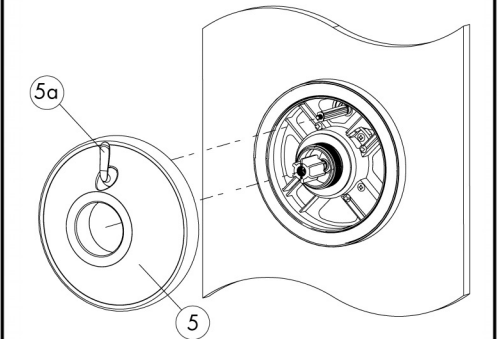

- 6 Align Handle Assembly (6) with Connector and Escutcheon. Keep Handle (6a) in a stationary vertical position as you thread Handle Hub (6b) on Mounting Base. Tighten until snug.

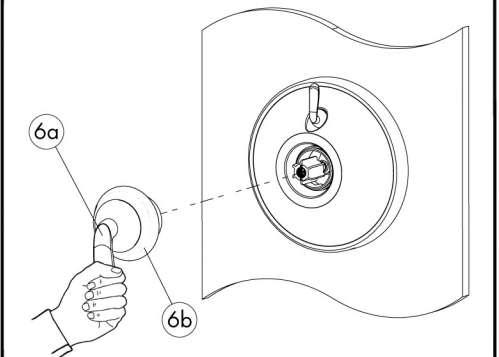

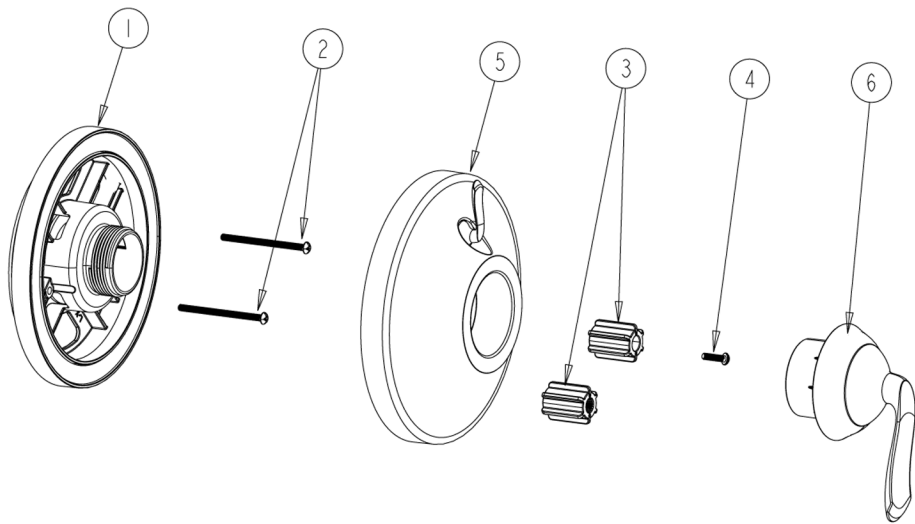

- RPG05-0874 (2) (3) (4)
- RPG10-0102-(PC,BN,PN) (5)
- RPG04-0391-(PC,BN,PN) (6)

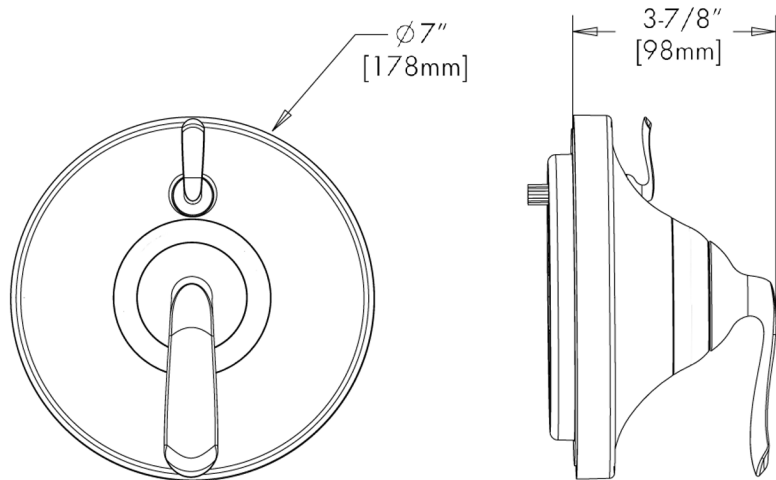

INSTRUCTIONS FOR MODELS

S-2500

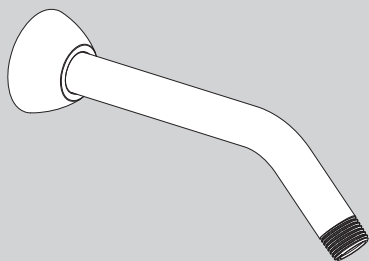

NEED HELP?

For additional assistance or service please contact:

SPEAKMAN® Company
400 Anchor Mill Road
New Castle, DE 19720

800-537-2107

customerservice@speakman.com

www.speakman.com

92-S-2500-R5

TOOLS AND SUPPLIES

Thread Seal
Tape



IMPORTANT



Be sure to read instructions thoroughly before beginning installation. Do not overtighten any connections or damage may occur.

SAFETY TIPS

Cover your drain to prevent loss of parts.

MAINTENANCE

Your new Shower Arm is designed for years of trouble-free performance. Keep it looking new by cleaning it periodically with a soft cloth. Avoid abrasive cleaners, steel wool and harsh chemicals as these will dull the finish and void your warranty.

WARRANTY

Additional warranty information can be found at:
www.speakman.com

- 1** Place the Escutcheon Plate (1) on a flat surface. Push the long end of the Shower Arm (2) down into the plate. This will help the teeth of the plate slide over the arm easier.

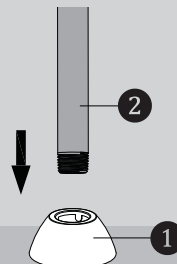

- 4** Position Escutcheon Plate (1) flat against wall.

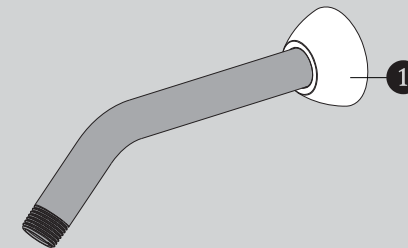

- 2** Once the Escutcheon Plate (1) is on the shower arm, slide the plate over the Shower Arm (2).

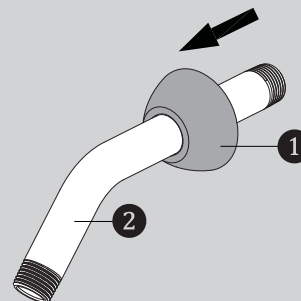

- 3** Apply Teflon Tape to inlet side of Shower Arm (2). Thread Shower Arm (2) into Female Pipe Fitting within the wall. Firmly tighten, and make sure Shower Arm (2) Outlet is pointing in a downward position.

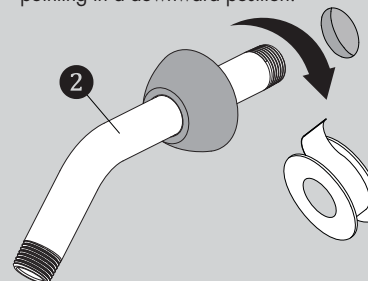

ROUGH IN DIMENSIONS

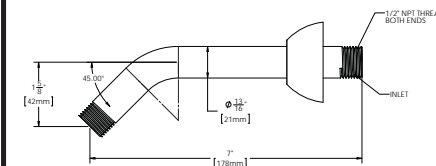
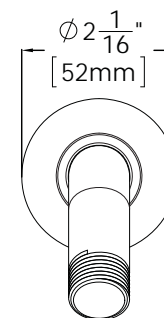

Specifications:

Supply Inlet: 1/2" NPT MALE

Outlet: 1/2" NPT MALE

INSTRUCTIONS FOR MODELS

S-3014
S-3014-E2
S-3014-E175

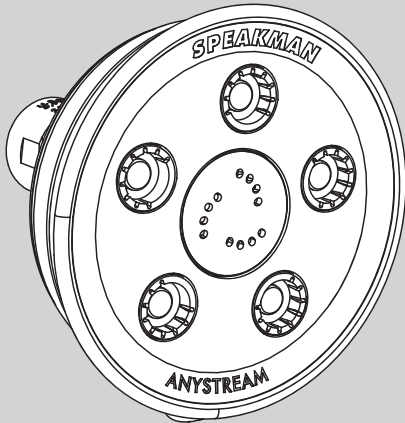

NEED HELP?

For additional assistance or service please contact:

SPEAKMAN® Company
400 Anchor Mill Road
New Castle, DE 19720

800-537-2107

customerservice@speakman.com

www.speakman.com

92-S-3014-04

TOOLS AND SUPPLIES

Thread Seal
Tape
(included)



Adjustable
Wrench



IMPORTANT



Be sure to read instructions thoroughly before beginning installation. Do not overtighten any connections or damage may occur.

SAFETY TIPS

Cover your drain to prevent loss of parts.

MAINTENANCE

Periodic cleaning using a mild soap and warm water will help keep your Showerhead's appearance in its original condition.

For best results, dry immediately with a soft, clean cloth. **DO NOT USE** harsh and/or abrasive cleaners.

To help restore the finish, occasionally apply a non-abrasive wax to your showerhead body (follow manufacturers' instructions).

On **CHROME PLATED SHOWER HEADS**, a two (2) part white vinegar, one (1) part water solution can be used to break down excessive mineral deposits on the sprays. Let the showerhead soak in the solution for about ½ hour then rinse thoroughly. Brush off any remaining mineral deposits if necessary.

DO NOT USE the vinegar/water treatment on any finish other than Chrome.

To reduce mineral build-up, turn the handle to **FLOOD** position to let the water drain out after every use.

WARRANTY

Additional warranty information can be found at:
www.speakman.com

- 1** Apply Thread Seal Tape to the outlet side of shower arm in a clockwise direction.

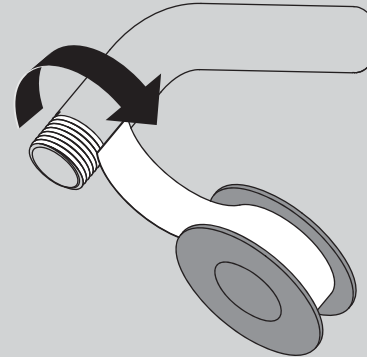

- 2** Thread Shower head onto shower arm by turning it in a clockwise direction. Tighten with adjustable wrench. Turn water supply on and check for leaks.

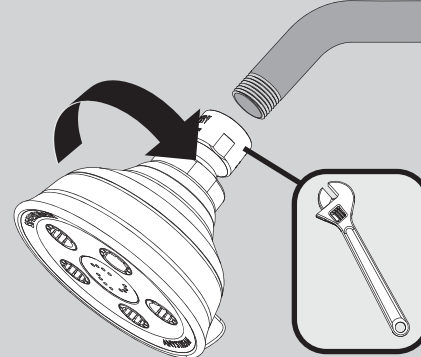

- 3** Adjust spray pattern by rotating faceplate to preferred Anystream® position.

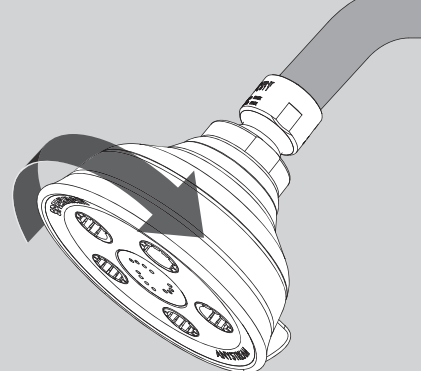

ROUGH IN DIMENSIONS

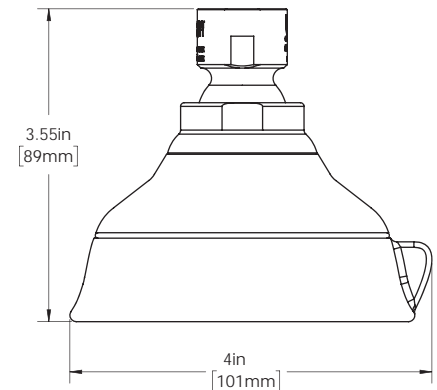
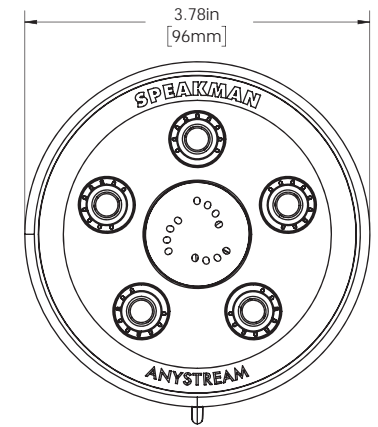

Model: S-3014

Max. Flow Rate: 2.5 gpm (9.5L/min)

Min. Flow Rate: 2.0 gpm (7.6 L/min) @ 45psi
FOR USE WITH AUTOMATIC COMPENSATING VALVES RATED AT 7.6 L/MIN (2.0 GPM) OR LESS.

Model: S-3014-E2

Max. Flow Rate: 2.0 gpm (7.6 L/min)

Min. Flow Rate: 1.5 gpm (5.7 L/min) @ 45psi
FOR USE WITH AUTOMATIC COMPENSATING VALVES RATED AT 6.6 L/MIN (1.75 GPM) OR LESS.

Model: S-3014-E175

Max. Flow Rate: 1.75 gpm (6.6 L/min)

Min. Flow Rate: 1.3 gpm (4.9 L/min) @ 45psi
FOR USE WITH AUTOMATIC COMPENSATING VALVES RATED AT 5.7 L/MIN (1.5 GPM) OR LESS.

Specifications:

Inlet: 1/2" NPT FEMALE