











Thank you for purchasing this quality product. Be sure to unpack carefully looking for small parts which may have come loose during shipment.

Read all instruction and study the drawing carefully before starting the assembly process.

HARDWARE PACK				
NO.	DRAWING	DESCRIPTION	SIZE	Q'TY
A		Bolt	5/16"x19MM	4 PCS
B		Lock Washer	5/16"	14 PCS
C		Flat Washer	5/16"	14 PCS
D		Allen Wrench	73*29*5mm	1 PC
E		Bolt	5/16"x35MM	4 PCS
F		Bolt	5/16"x60MM	6 PCS
G		Anti - Tip Kit		1 PC

PARTS LIST			
NO.	DRAWING	DESCRIPTION	Q'TY
1		Case Body	1 PC
2		Center Base Frame	1 PC
3		Left Leg 2 Right Leg 2	4 PCS
4		Base Shelf	1 PC

Tipping Restraint

Anti-tip kit is included for use. We recommend installing for safety reason.

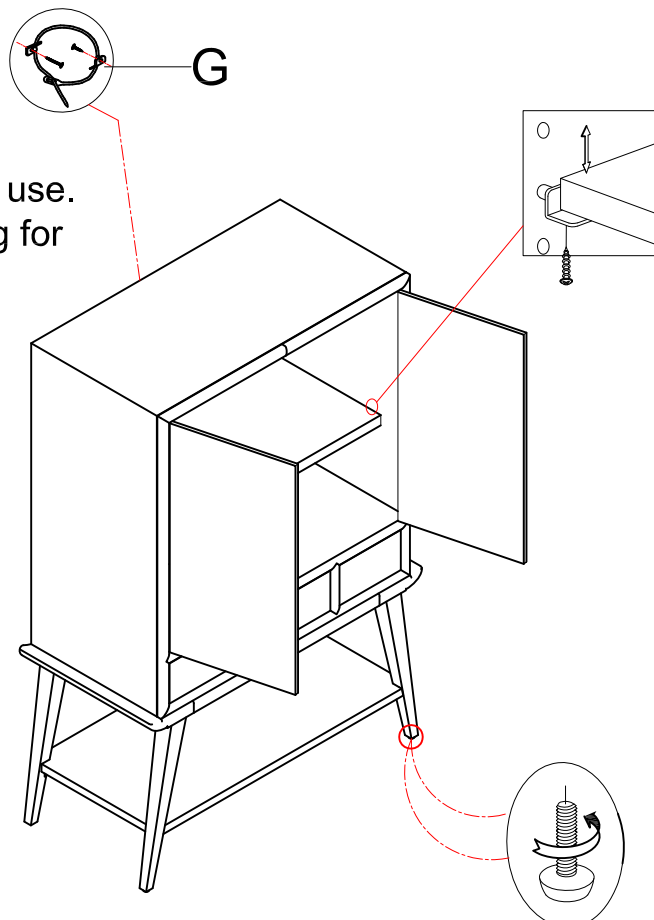

Adjust leveler if needed to level case on uneven floor.

Note: Anti-tip kit restraint is provided. Please follow the instructions enclosed with the pack.

Thank you for purchasing this quality product. Be sure to unpack carefully looking for small parts which may have come loose during shipment.

Read all instruction and study the drawing carefully before starting the assembly process.

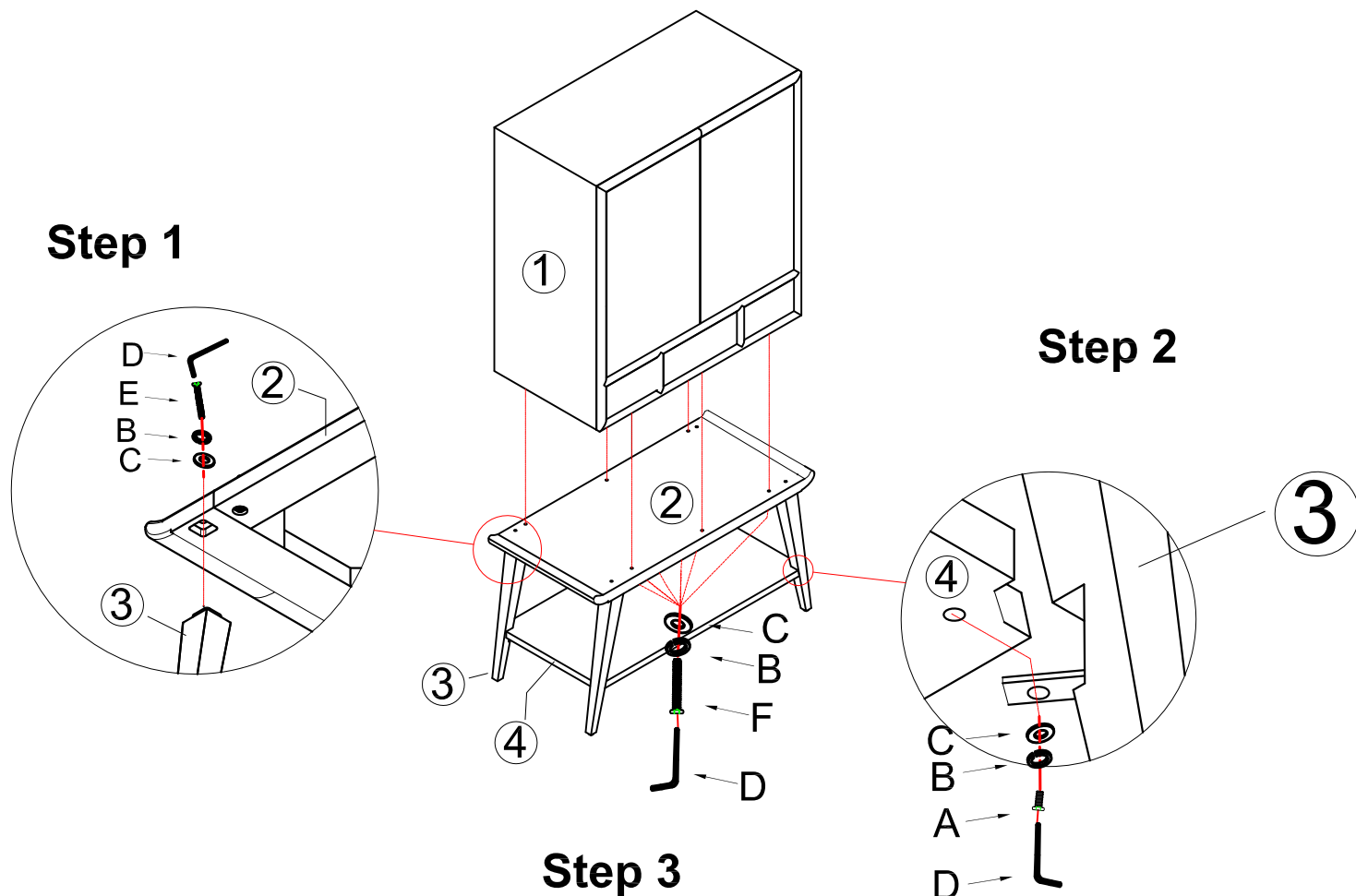

Note:

Please follow numbers and letters on legs when assemble.

Step1: Attached legs (3) to center base frame (2) by using flat washers (C), lock washers (B) and blots (E), do not fully tighten blots (E) at this step.

Step 2: Attached legs (3) to base shelf (4) by using flat washers (C), lock washers (B) and blots (A), tighten them with allen wrench (D).

Step 3: Attached base to case body (1) by using flat washers (C), lock washers (B) and blots (F), fully tighten them with allen wrench (D).