

Sentry ride-on scrubbers are versatile and efficient cleaning machines, designed to tackle large areas with ease. Their compact design strikes a balance between productivity and maneuverability, ensuring optimal performance. Ideal for education, retail, and healthcare environments, these scrubbers promise years of dependable service, meeting diverse cleaning needs with reliability.

- **Exceptional Productivity:** Scrub for up to four hours on a single fill of the 29-gallon solution tank.
- **User-Friendly:** Streamlined and intuitive controls facilitate easy training. Simple levers to manage water flow, adjust brush head position, and operate the squeegee.
- **Complete Feature Set:** All the essential features are included. Among these are a recovery tank designed for easy cleaning, non-marking wheels both in the front and rear, an hour meter, a break-away squeegee to protect the machine and the facility, a shock-resistant scrub deck protecting from accidental impacts, and a range of additional features to ensure cleaning efficiency.



SPECIFICATIONS

SENTRY 261R/301R/341R

Model	Sentry 261R	Sentry 301R	Sentry 341R
Item Number	HIL56103WET	HIL56104WET	HIL56105WET
Cleaning Path	26"	30"	34"
Productivity (up to sqft/hr)	41,979	48,438	54,896
Squeegee Width (in)	39	39	43.5
Disc Brushes (No.) In	(2) 13	(2) 15	(2) 17

Specifications		
Solution Tank	Gal	29
Recovery Tank	Gal	33
Battery Pack Voltage	V	24
Acoustic Level (Iso 11201)	Db (A)	62
Traction Motor	V/W	24 / 400
Forward Speed	MPH	2.5
Brush Motor(s)	(No.) V/W	(2) 24 / 500
Vacuum Motor	V/W	24 / 410
Brushes RPM	RPM/Min.	140
Brush Pressure	Lb	66 / 132
Battery Compartment Dimensions (L,H,W)	In	15.1 x 20.4 x 13.3
Battery Type		Flooded Lead-Acid
Batteries	(no) V/Ah	(4) 6V/240
Charging System		Onboard
Machine Dimensions (L,H,W)	In	59.4 x 52.0 x 27.0
Machine Weight (Without Battery)	Lb	490
Contents		2 - Medium Polypropylene Brush 2 - Pad holders 1 - Set of Battery Cables
Warranty		- Lifetime Tanks - Parts: 3 years - Service: 1 year - Travel: 1 year

Brushes	Sentry 261R	Sentry 301R	Sentry 341R
Soft PPL Brush (0.3mm)	HIL422189	HIL427715	HIL430696
Med PPL Brush (0.6 mm)	HIL422971	HIL427716	HIL430697
Firm PPL Brush (0.9 mm)	HIL422972	HIL427717	HIL430698
Abrasive 80 Grit Brush	HIL422981	HIL427719	HIL430699

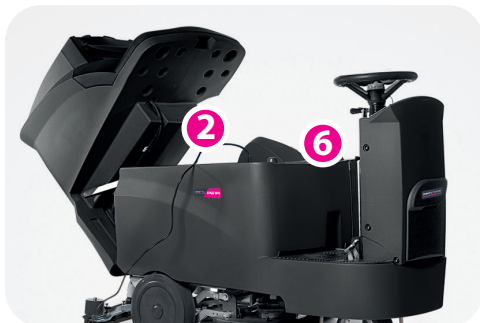

1. Simple controls for easy training.
2. Fully accessible recovery tank allows thorough cleaning.
3. The scrub deck swings inward to avoid damage to the machine and surroundings.
4. Non-marking, anti-slip front and rear wheels.
5. Break-away squeegee prevents damage to the machine and surroundings.
6. The seat flips upwards to reveal the battery compartment for easy inspection and maintenance.
7. Anti-roll bar protects against accidental tipping.

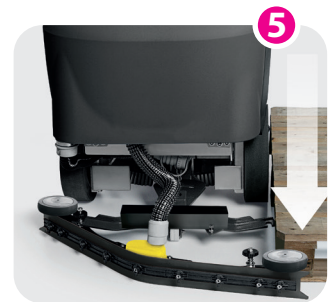

SCAN FOR INFO



HILLYARD
The Cleaning Resource®

PO Box 909
St. Joseph, MO 64502
www.hillyard.com

LIT-SENTRY-261R-0324

Subject to change without notice.