



Extended Warranty  
Sign Up

E-1

# Welcome home!

**FT6324BKS**

Teamson Home  
38 inch Height  
Fountain

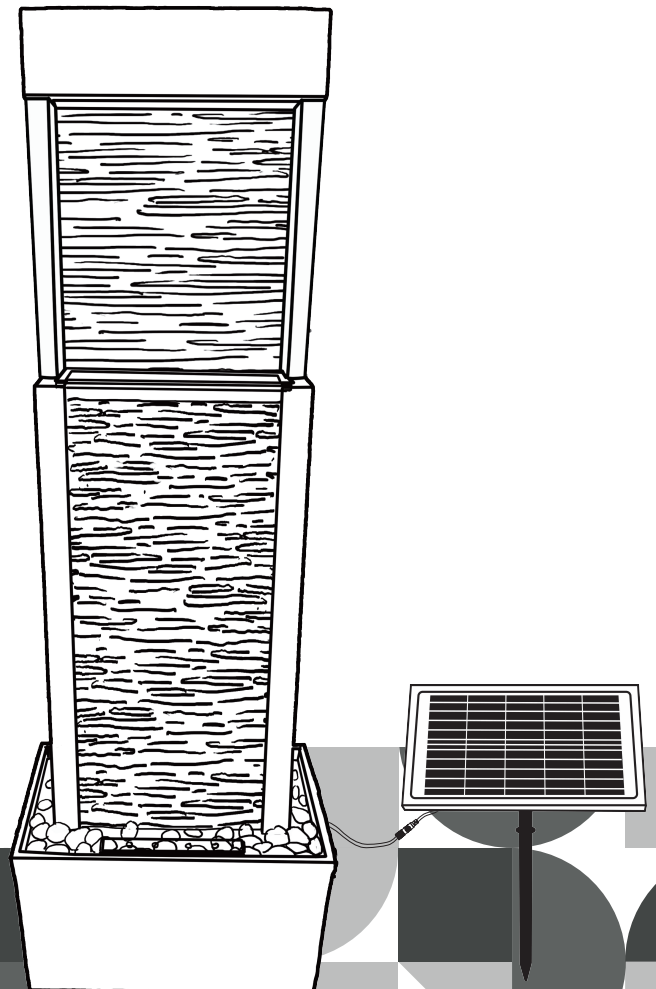

# Warranty

All components are warranted by the manufacturer for a period of 30 days after the date of purchase by the original owner against defects in materials & workmanship under normal use. If it is appropriate to replace your product due to specific defects, the manufacturer will replace the purchase with the same product or a comparable product.

For specific instructions on how to obtain warranty service for your product, please contact Customer Service using the contact information provided.

## Global Customer Service

**USA / CA** — ✉ [support@teamson.com](mailto:support@teamson.com)  
+1(770) 246-4898  
Mon - Fri 9 AM - 4 PM EST



**EU / UK** — ✉ [support@teamson.co.uk](mailto:support@teamson.co.uk)  
+44(0)1952-916-050  
Mon - Thur 9 AM - 5 PM GMT  
Fri 9 AM - 4 PM GMT



**ASIA** — 深圳办公室：  
✉ [sales\\_ec@teamson.com](mailto:sales_ec@teamson.com)  
+86(0755)8885-3558.分机号108  
Mon - Sat 9 AM - 5 PM GMT+8

台北辦公室：

✉ [support@teamson.com.tw](mailto:support@teamson.com.tw)  
+886(2)2556-6268  
Mon - Fri 9 AM - 5 PM GMT+8



**AU** — ✉ [support@teamson.com.au](mailto:support@teamson.com.au)

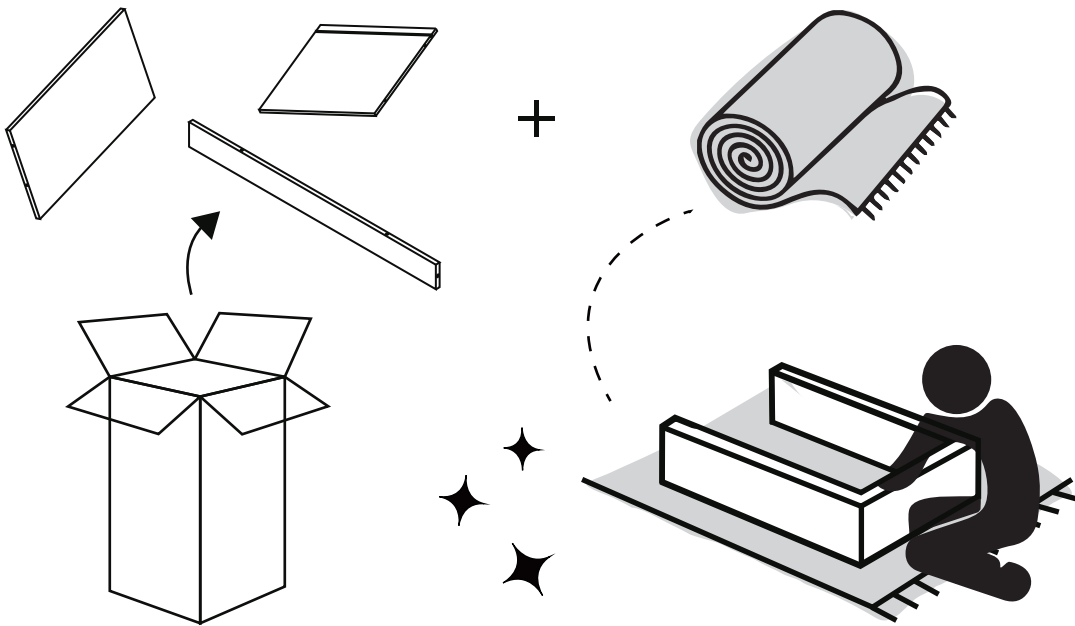
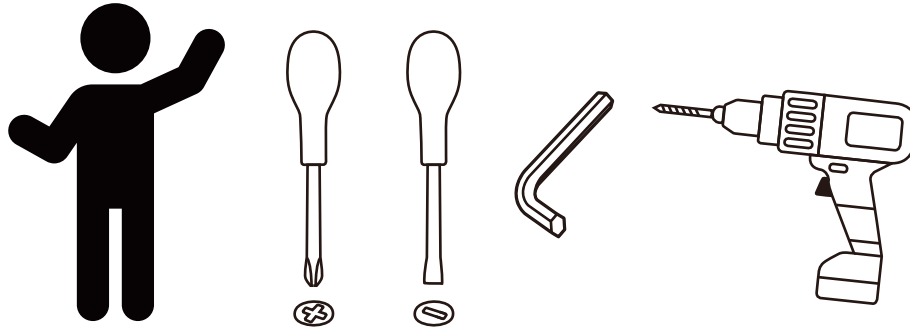

Any questions? Please contact our customer support team by email or phone. We are always ready to assist you! Please have the product item number ready, (located on the first page of this instruction manual) and your order number available.

**NOTE:**

- 1.CHARGE THE SOLAR UNIT FOR AT LEAST 2 DAYS BEFORE ASSEMBLY WATER CONTROL UNIT FOR USING.
- 2.TH WORKING TIME PER DAY WILL BE VARIOUS AFFECTED BY DIRECT SUNSHINE TIMING UPON WEATHER AND SEASON.

## Overview

- 1.The solar panel needs to be in direct sunlight for full power to operate the water control unit. When the solar panel is in the shadow or the sunlight is weak, the water control unit will not operate.
- 2.This solar panel is also equipped with a battery pack and is charged by the sunlight as a power source when there is not enough sunlight to power the fountain during the night.
- 3.Please disconnect the water control unit from the solar panel when it is not in use for a long period of time. The switch does not need to be turned off for normal charging once the steps for first uses have been executed on page 6 of this manual.
- 4.To power the water control unit, press the button (switch) on the back of the solar panel.  
Turn ON: fountain will work.  
Turn OFF: to charge the batter; water control unit and LED light will not work.

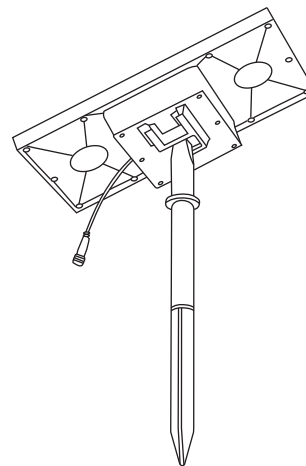
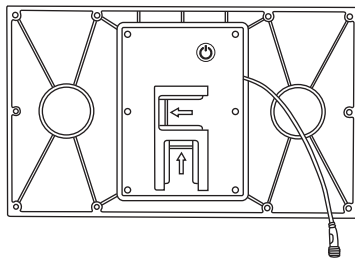

## Assembling and Using Your Product

1. Unpack all components carefully.
2. Assemble the fountain on a surface that will not be damaged by water.
3. Lead the water tube and LED light cables through the hole in the back of the fountain.
4. Connect the water tube to the water control unit outlet on top of the fountain.
5. Connect the LED lights to the LED light cables, then connect the LED light cables to the water control unit.
6. Place the water control unit upright into the fountain basin at the bottom of the fountain.
7. Connect the water control unit power cord to the solar panel.
8. Secure the fountain top onto the fountain.
9. Place the completed fountain in the desired location.
10. Attach the support to the solar panel and insert the stake.  
Place the solar panel where it will receive direct sunlight.
11. Add approximately 3.5 gallons / 13.25 liters of water to the fountain basin at the bottom.
12. Switch the solar panel to "ON" and enjoy!

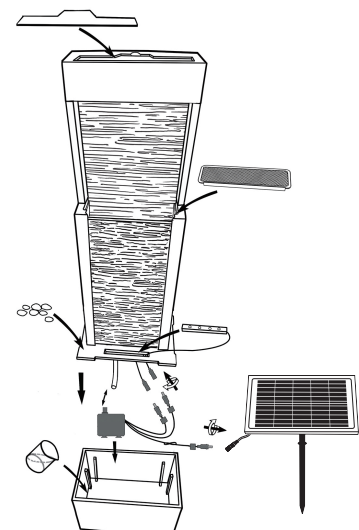

**Scan for assembly instructions.**

## Cleaning and Maintenance

**Water Control Unit:** If the water control unit starts to lose power or stops working, check for the build-up of sediment, scale, or dirt in the water control unit. Remove the water control unit filter, the gland, and the rotor. Clean them with a stream of fresh water and a small brush if needed to remove the debris.

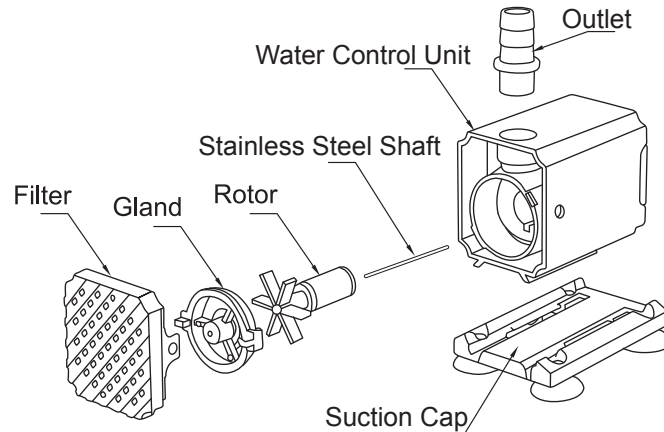

**Water raining drainage hole cleaning:** When finding the water raining do not fall smoothly, please take out the top water bin to clean and use a pin to clean the drainage hole.

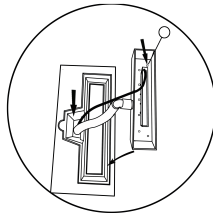

**Solar Panel:** The panel should be cleaned periodically with a soft tissue. Regular cleaning of the panel is advised to maintain optimum conversion of the sun's energy into direct current.

## Troubleshooting Guide

1. If the water control unit does not operate when the solar panel is in full sunlight, follow instructions below:
  - a. If the connection to the solar unit is compromised: Check the connection and reattach.
  - b. If the rotor is blocked: Clean the water control unit (see above for instructions) and remove any debris from the rotor with a small brush or stream of water.
2. The water control unit is operating, but there is no water running through the fountain:
  - a. Check the tubes or water control unit for sediment or scale build-up. Clean with water or a small brush (if applicable)





## Technical Data

Solar Panel:	11W
Water Control Unit Operation Voltage:	12V DC
Water Control Unit:	8W
Water Flow Max:	600L/H
Water Lift Max:	1.15M
LED Light:	2 LED Yellow Light
Lithium Battery:	3.7V/4800mAH
Water Control Unit Waterproof Rate:	IPX8
Panel Waterproof Rate:	IP64

## Caution

1. Do not strike the solar panel.
2. Do not let the water control unit run dry.
3. If the fountain is not in use for a long period of time:
  - a. Always disconnect the water control unit from the solar panel.
  - b. Fully charge the panel for 2 days before turning it back on again.
4. Do not lift the water control unit by the power cord.
5. Use freshwater only.

Water control unit performance in different weather conditions.

Weather	Performance of the water control unit	Charging of the battery
	Solar energy runs the water control unit and charges the battery at the same time.	Battery will be fully charged in 1 day.
	Solar energy runs the water control unit and supplies very little extra energy to the battery.	Battery will be fully charged in 2 to 3 days.
	Water control unit could only run by using the stored energy in the battery pack.	Battery will not be charged.
	Water control unit could only run by using the stored energy in the battery pack.	Battery will not be charged.

The working time per day of the water control unit will vary depending on the amount of direct sunlight exposure, weather conditions, and time of year.



**Scan for assembly instructions.**

## Instruction for Solar Panel

Solar lights and water control unit work by using electricity generated by the solar panel to charge internal batteries. These batteries are then used to power the light and water control unit when there is no sunlight. When switched "ON", the lights and water control unit are triggered by a light sensor. The duration of illumination and power will depend on the amount of sunlight and the charge received by the solar panels.

### POSITION

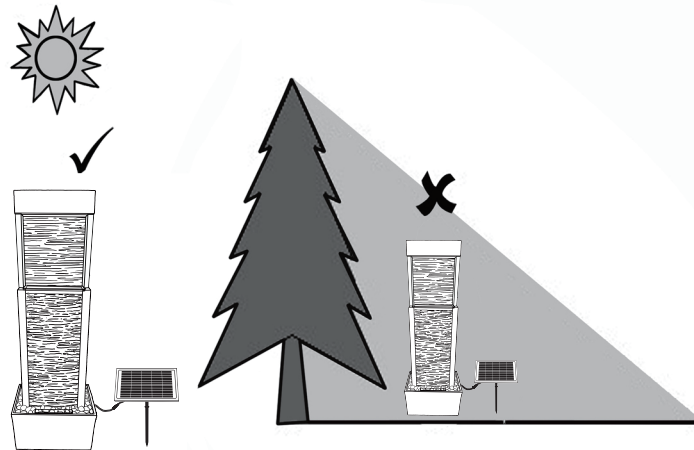

Position the solar panel to receive the maximum amount of sunlight

### FIRST USE

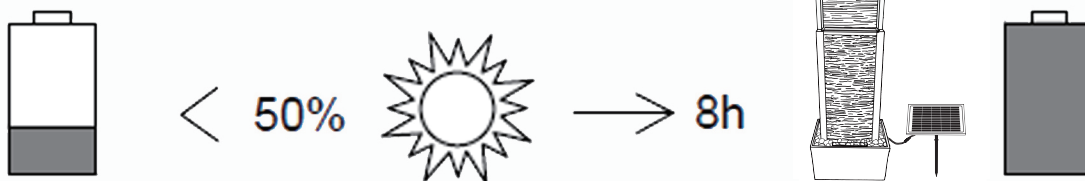

While there may be some initial charge in the battery, fully charging it before first use is recommended. Leave the switch in the "OFF" position for 2 sunny days to ensure that the battery is fully charged. Once fully charged, switch to "ON" position and the lights and water will come on automatically. For best performance, make sure the solar panel has been fully charged in direct sunlight for approximately 6-7 hours.

NOTE: The diagrams shown are for illustrative purposes only and are not to scale.



Scan for assembly instructions.

# Warranty

## LIMITATIONS

All components are warranted by the manufacturer for a period of 30 days after the date of purchase by the original owner against defects in materials & workmanship under normal use. If it is appropriate to replace your product due to specific defects, the manufacturer will replace the purchase with the same product or a comparable product.

## GENERAL TERMS & CONDITIONS

1. Proof of purchase is required to request a claim under this warranty.
2. This warranty applies only to manufacturer errors & defects. The warranty applies to the following:
  - a. Breaks and cracks in the product that originated with the manufacturer
  - b. Missing pieces
  - c. Stains that occurred during the manufacturing process
3. This warranty does not apply to the following:
  - a. Damage due to improper loading, handling, or transportation
  - b. Any costs associated with the installation and removal of products or parts subject to this warranty
  - c. Acts of God
  - d. Products which have been subject to negligence, abuse, accident, misapplication, tampering, alteration, or modification
  - e. Products which have been subject to improper installation, operation, maintenance, repair, or storage
  - f. Products which have been subject to defects that occur when this product is used incorrectly and/or outside of normal application purposes
  - g. Products which have had, including but not limited to, operational failures caused by corrosion, rust, or other foreign materials in the system, or operation at pressures in excess of recommended maximums
  - h. All other possible defects not mentioned here that would not have occurred during manufacturing or during correct, routine use of the item

## INSTRUCTIONS

For specific instructions on how to obtain warranty service for your product, please contact Customer Service using the contact information provided. In most circumstances, you will need to return your product either in its original packaging or in equally protective packaging to the address specified by Customer Service.

Before delivering your product for warranty service, it is your responsibility to remove all personal items and belongings you may have stored in your product. Teamson is not responsible for the possible loss, destruction, or damage of any personal items or belongings that have been sent alongside the product.

## DISCLAIMER

Any oral statements made about the product by the seller, the manufacturer, the representatives, or any other parties do not constitute warranties, should not be relied upon by the user, and are not part of the contract for sale. The sellers and manufacturers only obligation, and buyers only remedy shall be for the manufacturer to either replace and /or repair at the manufacturers sole discretion, the product as described above. Neither seller nor the manufacturer shall be liable for any injury, loss or damages for lost profits, lost sales, injury to person or property, or any other incidental or consequential loss arising from any cause whatsoever, no matter whether based upon warranty, contract, negligence or other misuse, and the buyer and user agree that no other remedy shall be available to them. Before using, the buyer and user shall determine the suitability of the product for intended use, and assume all risk and liability whatsoever in connection therewith. The warranty and remedy described in this limited warranty is an exclusive warranty and remedy in lieu of any other warranty or remedy expressed or implied. All other warranties and remedies are hereby expressly excluded, including but not limited to any implied warranty of merchantability of fitness for any particular purpose.

## OTHER LEGAL RIGHTS

This warranty gives the buyer and user specific legal rights, and buyer and user may also have other rights which vary from state to state. Some states do not allow exclusions or limitation of incidental or consequential damages, so the above limitations or exclusions may not apply to you.

## THANK YOU

We appreciate the trust and confidence you have placed in Teamson through the purchase of this product. We strive to continually create quality products designed to enhance your home and life. Visit us online to see our full line of products available for your home décor, toy, and pet needs. Thank you for choosing Teamson!



Scan for assembly instructions.



FR  
Pensez à donner ou recycler.



Association



Magasin



Déchèterie

<https://quefairedelesdechets.fr>

# Exploded Drawing

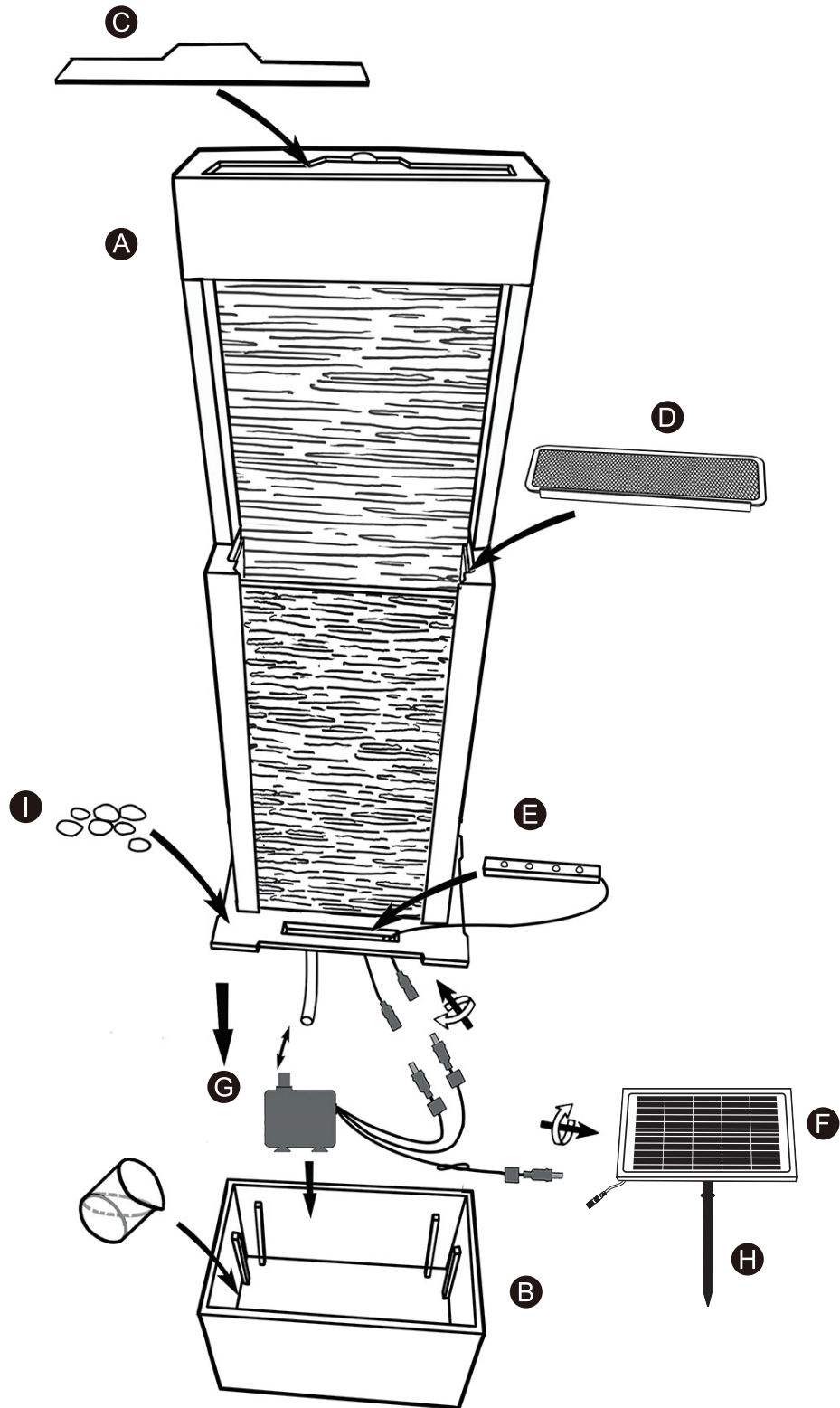

Scan for assembly instructions.

# Product Parts

A

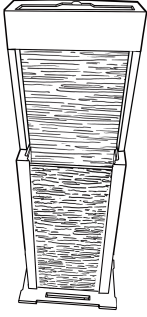

Fountain  
1 PC

B

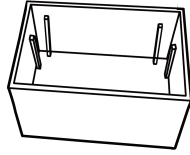

Basin  
1 PC

C



Cover  
1 PC

D

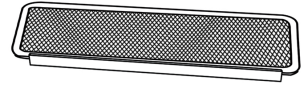

Water splashing  
proof screen  
1 PC

E

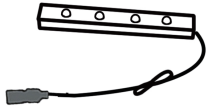

LED Light (Pre-assembled)  
1 PC

F

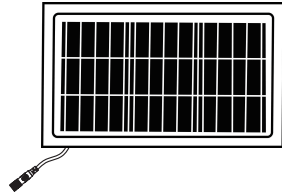

Solar Panel  
1 PC

G

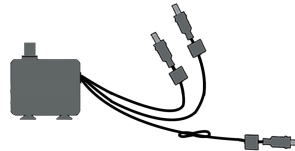

Water Control Unit  
1 PC

H



Stake  
1 PC

I

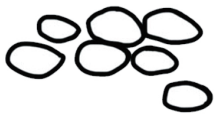

Pebble  
1 BAG

J



Brush  
(Cleaning water control unit)  
1 PC



Scan for assembly  
instructions.

## Step 1

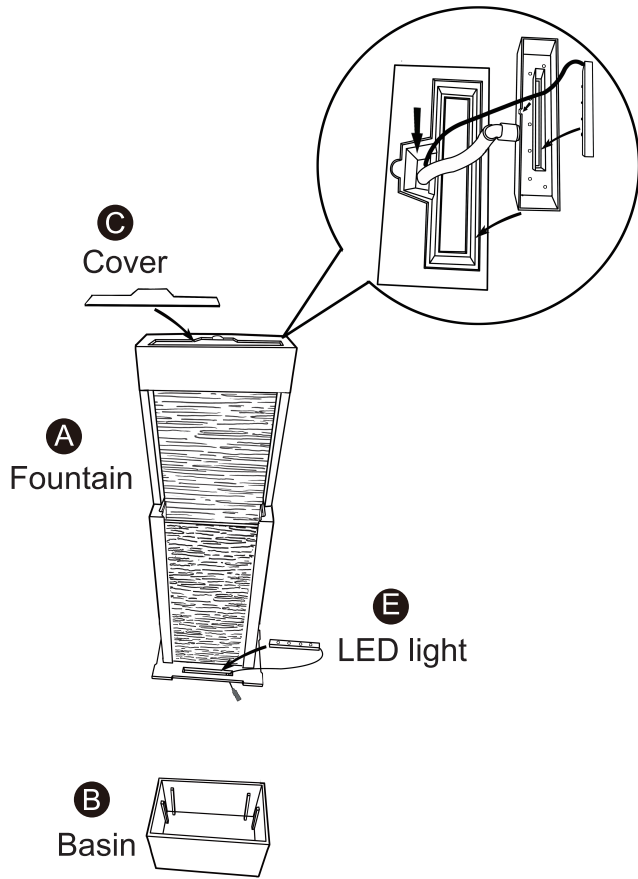

## Step 2

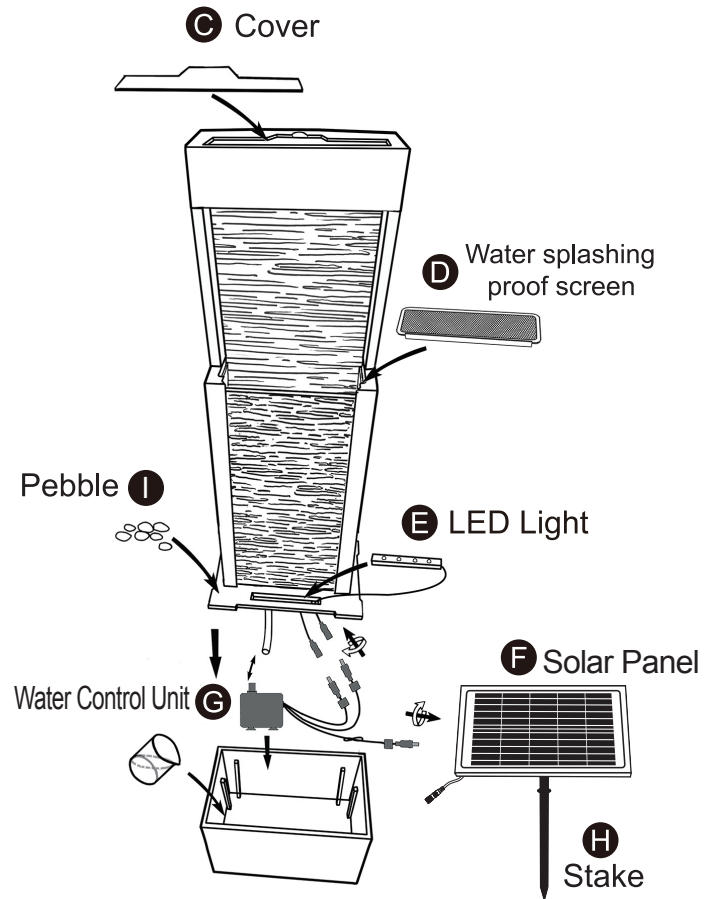

Scan for assembly instructions.

