

CyberPower

Automatic Transfer Switch

USER'S MANUAL

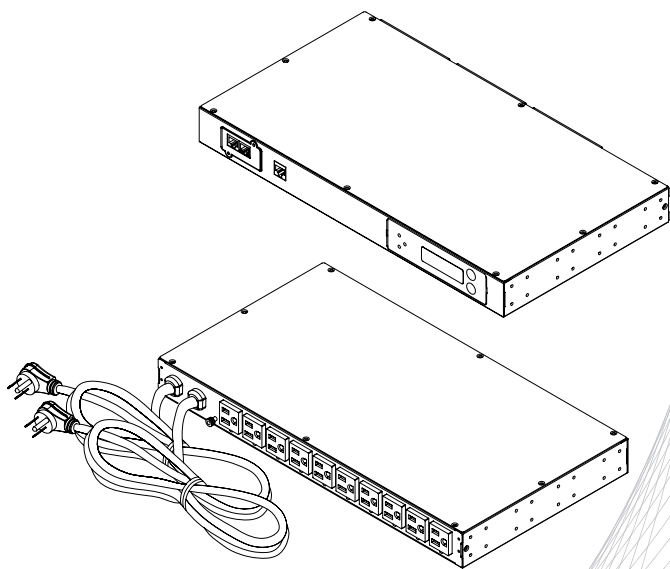

Table of Contents

Overview	1
Model List	1
Product Contents	2
For 1U Models	2
For 2U Models	3
Product Features	4
Front/Rear Panel Description (1U 15A Models)	4
Technical Specifications	4
Front/Rear Panel Description (1U 20A Models)	5
Technical Specifications	5
Front/Rear Panel Description (2U 30A Models)	6
Technical Specifications	6
Front/Rear Panel Description (2U 32A Models)	7
Technical Specifications	7
Installation Guide	8
ATS PDU Configuration	8
Front Mounting	9
For 1U Models	9
For 2U Models	10
Rear Mounting	11
For 1U Models	11
For 2U Models	13
Replacing LCD Panel	15
Electrical Installation	15
Power Cord Locking - For IEC Type ATS PDU	16
Input Power Cord	16
Output Power Cord	16
Network Installation	17
Operation	18
Remote Management	18
Web	18
Telnet and SSH	18
SNMP	18
Local Management	18
LCD Operation	18
LED Indicators	19
Environmental Monitoring (optional)	19
Device Reset	19
Unattended/Automatic Shutdown	19
Firmware Upgrade	20
ATS PDU	20
LCD	21
RMCARD	23
Troubleshooting	25
Conformance Approvals	26
Customer Service & Warranty	27
Appendix A-Hyper Terminal	28
Appendix B-Power Device Network Utility	29

Overview

CyberPower Automatic Transfer Switches PDUs with dual input for power provide redundant and increased reliability for critical devices with a single power plug. Users can define the preferred input power source. When a selected source is unstable or unavailable, the ATS PDU will switch to the second power source to constantly provide power to connected devices. The entire ATS PDU series are designed with LED and LCD interfaces for users to easily observe power status and device load. On-site power management is accomplished as users can configure power settings, via LCD interface, according to local power condition. Available in both switched and metered/monitored configurations, users have a broad base of options to select the ATS PDU that best fits their needs.

WARNING: This automatic transfer switch has dual power cords (A & B) to provide redundant power sources to devices with single power supplies and can be plugged into separate compatible sources* to ensure continuous access. Users select the preferred source as the primary input. CyberPower Smart App Online and Sinewave series UPS are highly recommended for use as the power source.

***Note:** Only sine wave AC power sources are compatible with this ATS PDU. Simulated sine wave AC power sources are NOT compatible.

Model List

Switched Series	Metered/Monitored Series
1U	1U
PDU15SW10ATNET	PDU15M10AT
PDU20SW10ATNET	PDU20M10AT
PDU20SWT10ATNET	PDU20MT10AT
PDU20SWHV10ATNET	PDU20MHV10AT
PDU15SWHVIEC12ATNET	PDU15MHVIEC12AT
PDU20SWHVIEC10ATNET	PDU20MHVIEC10AT
PDU20SWHVCEE10ATNET*	PDU20MHVCEE10AT*
2U	2U
PDU30SWT17ATNET	PDU30MT17AT
PDU30SWHV19ATNET	PDU30MHV19AT
PDU32SWHVCEE18ATNET*	PDU32MHVCEE18AT*

*Selected models may not be available in certain regions. Please contact your CyberPower sales team for more information.

Safety Precautions

Read the following before installing or operating the Automatic Transfer Switches (ATS) PDU:

- Use only the supplied hardware to attach the mounting brackets.
- The ATS PDU must be plugged into a single phase three-wire, grounded outlet on a circuit that is protected by a fuse or circuit breaker. For PDU15xxxxx series, please use a 15A circuit protector. For PDU20xxxxx series, please use a 20A circuit protector. For PDU30xxxxx series, please use a 30A circuit protector. Connection to any other type of power outlet may result in a electrocution hazard.
- Do not use extension cords or adapters with these ATS PDUs.
- Never install an ATS PDU or associated wiring or equipment during a lightning storm.
- Ensure that the power cord, plug, and socket are in good condition.



To prevent the risk of fire or electrocution, this ATS PDU should be installed in a temperature and humidity controlled indoor area free of conductive contaminants. Do not install this ATS PDU where excessive moisture or heat is present.



Before using, please check to ensure the package contains all the items shown below. If there are missing parts, please contact your local CyberPower sales team for technical support.

Product Contents

For 1U Models

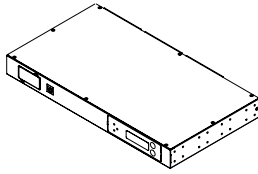

ATS PDU

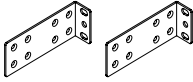

Mounting Bracket x 2



24 (M4x8) Bracket Mounting Screws
(Includes eight spares)

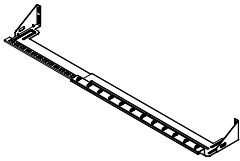

Cord Retention Tray



4 (M3x4) Cord Retention Tray
Mounting Screws

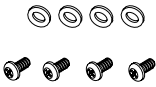

6 (M5x12) Rack Mounting Screws/
6 Washers (Includes two spares for each)

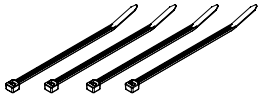

Cable Ties
Qty.: 18 (NEMA Outlet)
Qty.: 30 (IEC Outlet)

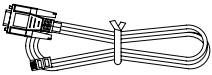

RJ45/DB9 Serial Port
Connection Cable



Jumper (Switched type only)

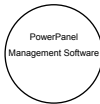

User's Manual, Registration & Software Download Cards

Below items only provided with IEC type ATS PDU

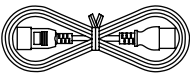

Power Cord 10 feet
IEC-320 C13/C14 x 2
(PDU15SWHVIEC12ATNET/
PDU15MHVIEC12AT Model Only)

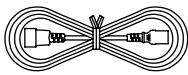

Power Cord 10 feet
IEC-320 C19/C20 x 2
(PDU20SWHVIEC10ATNET/
PDU20MHVIEC10AT Model Only)

Product Contents

For 2U Models

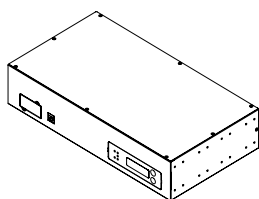

ATS PDU

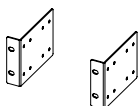

Mounting Bracket x 2



24 (M4x8) Bracket Mounting Screws
(Includes eight spares)

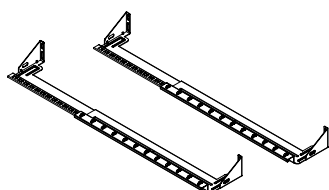

Cord Retention Tray X 2



8 (M3x4) Cord Retention Tray
Mounting Screws



6 (M5x12) Rack Mounting Screws/
6 Washers (Includes two spares for each)

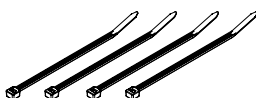

Cable Ties
Qty.: 30 (NEMA Outlet)
Qty.: 50 (IEC Outlet)

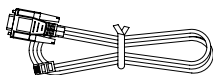

RJ45/DB9 Serial Port
Connection Cable



Jumper (Switched type only)

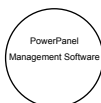
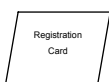

User's Manual, Registration & Software Download Cards

Product Features

Front/Rear Panel Description (1U 15A Models)



NEMA Type

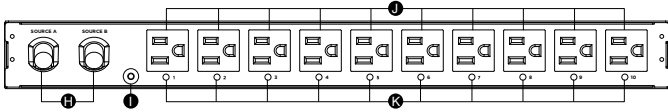

IEC Type

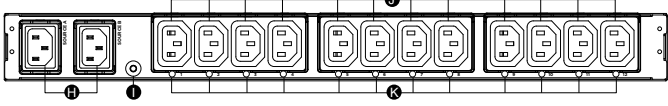

- A. SNMP/HTTP Network Slot
Allows users to remotely control and monitor the ATS PDU when installed with CyberPower's Remote Management Card.
- B. Serial Port (RJ45 modular port)
Use serial port to connect with PC and execute local control of the ATS PDU.
- C. Source Indicator
Indicates Source A or B is in use. When both sources are normal, selected source shows constant green LED while another source shows blinking green LED.
- D. Output Indicator
Indicates load condition of the ATS PDU.
- E. Multifunction LCD Readout
Displays various ATS PDU information such as power and load conditions.
- F. Select Button
Use to control the LCD screen and toggle through the available informational options.
- G. Enter Button
Use to choose selected items, enter to next level menu or return to previous menu.
- H. AC Inlet/AC Power Cord
Use to connect ATS PDU to utility power or UPS.
- I. Ground Stud
Use to ground the ATS PDU.
- J. AC Output Receptacles
Provides power distribution for connected equipment.
- K. Outlet Indicator (switched series only)
When the LED is on, the outlet is providing power to connected equipment.

Technical Specifications

	Switched Series		Metered Series	
Model Name	PDU15SW10ATNET	PDU15SWHVIEC12ATNET	PDU15M10AT	PDU15MHVIEC12AT
Input				
Nominal Voltage	100-120V	200-240V	100-120V	200-240V
Frequency	50/60Hz			
Derated Input Current	12A	12A(UL)/10A(CE)	12A	12A(UL)/10A(CE)
Plug Type	(2) NEMA 5-15P	(2) IEC-320 C14	(2) NEMA 5-15P	(2) IEC-320 C14
Power Cord Type	SR (14 AWG)	Socket	SR (14 AWG)	Socket
Power Cord Length	10 ft/3.05 m			
Output				
Nominal Voltage	100-120V	200-240V	100-120V	200-240V
Derated Output Current	12A	12A(UL)/10A(CE)	12A	12A(UL)/10A(CE)
Outlet Type	NEMA 5-15R	IEC-320 C13	NEMA 5-15R	IEC-320 C13
Outlet Number	10	12	10	12
Transfer Time	Typical: 8-12ms 16ms max @ 60Hz/ 18ms max @ 50Hz			
Management and Communications				
Multifunction LCD Readout	Voltage, Frequency, Load, Current, HW/FW Version, Network Information			
Software	PowerPanel® Business Edition			
SNMP/ HTTP Capable	Yes, with RMCARD		Yes, with optional RMCARD	
Connectivity	RJ45 (Serial Port)			
Sensor Capable	Optional			
Physical				
Dimension (W x H x D)	17.05" x 1.75" x 9.3"/433mm x 44mm x 236mm			
Environmental				
Humidity	0 to 95% Non-condensing			
Altitude	13100 ft/4000 m			
Temperature	32°F to 113°F/0°C to 45°C			
Safety Approvals				
Certifications	UL 60950-1 FCC Class A	UL 60950-1 CE, FCC Class A	UL 60950-1 FCC Class A	UL 60950-1 CE, FCC Class A

* All specifications are subject to change without notice.

Product Features

Front/Rear Panel Description (1U 20A Models)



NEMA Type

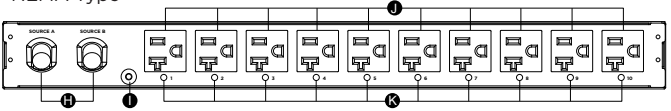

IEC Type

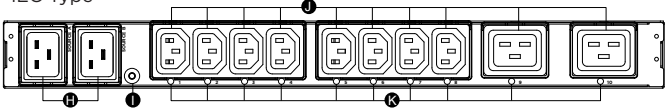

- A. SNMP/HTTP Network Slot
Allows users to remotely control and monitor the ATS PDU when installed with CyberPower's Remote Management Card.
- B. Serial Port (RJ45 modular port)
Use serial port to connect with PC and execute local control of the ATS PDU.
- C. Source Indicator
Indicates Source A or B is in use. When both sources are normal, selected source shows constant green LED while another source shows blinking green LED.
- D. Output Indicator
Indicates load condition of the ATS PDU.
- E. Multifunction LCD Readout
Displays various ATS PDU information such as power and load conditions.
- F. Select Button
Use to control the LCD screen and toggle through the available informational options.
- G. Enter Button
Use to choose selected items, enter to next level menu or return to previous menu.
- H. AC Inlet/AC Power Cord
Use to connect ATS PDU to utility power or UPS.
- I. Ground Stud
Use to ground the ATS PDU.
- J. AC Output Receptacles
Provides power distribution for connected equipment.
- K. Outlet Indicator (switched series only)
When the LED is on, the outlet is providing power to connected equipment.

Technical Specifications

	Switched Series		Metered Series	
Model Name	PDU20SW10ATNET PDU20SWT10ATNET	PDU20SWHVT10ATNET PDU20SWHVCEE10ATNET PDU20SWHVIEC10ATNET	PDU20M10AT PDU20MT10AT	PDU20MHVT10AT PDU20MHVCEE10AT PDU20MHVIEC10AT
Input				
Nominal Voltage	100-120V	200-240V	100-120V	200-240V
Frequency	50/60Hz			
Derated Input Current	16A			
Plug Type	(2) NEMA 5-20P (2) NEMA L5-20P	(2) NEMA L6-20P (2) IEC 309 16A (2) IEC-320 C20	(2) NEMA 5-20P (2) NEMA L5-20P	(2) NEMA L6-20P (2) IEC 309 16A (2) IEC-320 C20
Power Cord Type	SR (12AWG)	SR (12AWG) Socket	SR (12 AWG)	SR (12AWG) Socket
Power Cord Length	10 ft/3.05 m			
Output				
Nominal Voltage	100-120V	200-240V	100-120V	200-240V
Derated Output Current	16A	C13: 12A (UL) 10A (CE) C19: 16A	16A	C13: 12A (UL) 10A (CE) C19: 16A
Outlet Type	NEMA 5-20R	(8) IEC C13 (2) IEC C19	NEMA 5-20R	(8) IEC C13 (2) IEC C19
Outlet Number	10	8+2	10	8+2
Transfer Time	Typical: 8-12ms 16ms max @ 60Hz/ 18ms max @ 50Hz			
Management and Communications				
Multifunction LCD Readout	Voltage, Frequency, Load, Current, HW/FW Version, Network Information			
Software	PowerPanel® Business Edition			
SNMP/ HTTP Capable	Yes, with RMCARD		Yes, with optional RMCARD	
Connectivity	RJ45 (Serial Port)			
Sensor Capable	Optional			
Physical				
Dimension (W x H x D)	17.05" x 1.75" x 9.3"/433mm x 44mm x 236mm			
Environmental				
Humidity	0 to 95% Non-condensing			
Altitude	13100 ft/4000 m			
Temperature	32°F to 113°F/0°C to 45°C			
Safety Approvals				
Certifications	UL 60950-1 FCC Class A	UL 60950-1 FCC Class A UL 60950-1 CE, FCC Class A	UL 60950-1 FCC Class A	UL 60950-1 FCC Class A UL 60950-1 CE, FCC Class A

* All specifications are subject to change without notice.

Product Features

Front/Rear Panel Description (2U 30A Models)

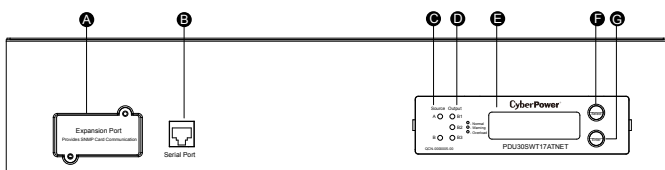

NEMA Type

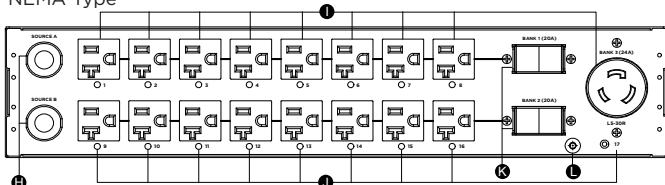

IEC Type

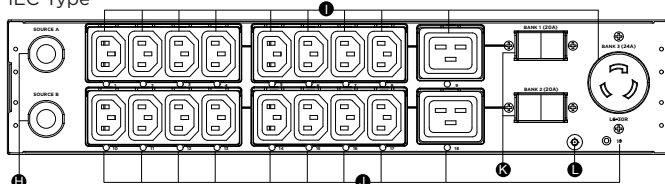

- A. SNMP/HTTP Network Slot
Allows users to remotely control and monitor the ATS PDU when installed with CyberPower's Remote Management Card.
- B. Serial Port (RJ45 modular port)
Use serial port to connect with PC and execute local control of the ATS PDU.
- C. Source Indicator
Indicates Source A or B is in use. When both sources are normal, selected source shows constant green LED while another source shows blinking green LED.
- D. Output Indicator
Indicates load condition of the ATS PDU.
- E. Multifunction LCD Readout
Displays various ATS PDU information such as power and load conditions.
- F. Select Button
Use to control the LCD screen and toggle through the available informational options.
- G. Enter Button
Use to choose selected items, enter to next level menu or return to previous menu.
- H. AC Inlet/AC Power Cord
Use to connect ATS PDU to utility power or UPS.
- I. AC Output Receptacles
Provides power distribution for connected equipment.
- J. Outlet Indicator (switched series only)
When the LED is on, the outlet is providing power to connected equipment.
- K. Circuit Breaker
Provides output overload protection.
- L. Ground Stud
Use to ground the ATS PDU.

Technical Specifications

	Switched Series		Metered Series	
Model Name	PDU30SWT17ATNET	PDU30SWHVT19ATNET	PDU30MT17AT	PDU30MHVT19AT
Input				
Nominal Voltage	100-120V	200-240V	100-120V	200-240V
Frequency	50/60Hz			
Derated Input Current	24A			
Plug Type	(2) NEMA L5-30P	(2) NEMA L6-30P	(2) NEMA L5-30P	(2) NEMA L6-30P
Power Cord Type	SR (10 AWG)			
Power Cord Length	10 ft/3.05 m			
Output				
Nominal Voltage	100-120V	200-240V	100-120V	200-240V
Derated Output Current	5-20R: 16A L5-30R: 24A	C13: 12A C19: 16A L6-30R: 24A	5-20R: 16A L5-30R: 24A	C13: 12A C19: 16A L6-30R: 24A
Derated Output Current (each bank)	20A			
Bank Number	2			
Outlet Type	(16) NEMA 5-20R (1) NEMA L5-30R	(16) IEC C13 (2) IEC C19 (1) NEMA L6-30R	(16) NEMA 5-20R (1) NEMA L5-30R	(16) IEC C13 (2) IEC C19 (1) NEMA L6-30R
Outlet Number	17	19	17	19
Circuit Breaker	Yes			
Transfer Time	Typical: 8-12ms 16ms max @ 60Hz/ 18ms max @ 50Hz			
Management and Communications				
Multifunction LCD Readout	Voltage, Frequency, Load, Current, HW/FW Version, Network Information			
Software	PowerPanel® Business Edition			
SNMP/ HTTP Capable	Yes, with RMCARD		Yes, with optional RMCARD	
Connectivity	RJ45 (Serial Port)			
Sensor Capable	Optional			
Physical				
Dimension (W x H x D)	17.05" x 3.5" x 9.3"/433mm x 88mm x 236mm			
Environmental				
Humidity	0 to 95% Non-condensing			
Altitude	13100 ft/4000 m			
Temperature	32°F to 113°F/0°C to 45°C			
Safety Approvals				
Certifications	UL 60950-1, FCC Class A			

* All specifications are subject to change without notice.

Product Features

Front/Rear Panel Description (2U 32A Models)

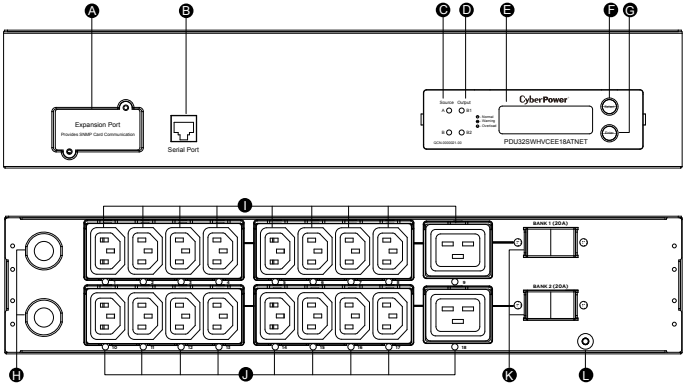

- A. SNMP/HTTP Network Slot
Allows users to remotely control and monitor the ATS when installed with CyberPower's Remote Management Card.
- B. Serial Port (RJ45 modular port)
Use serial port to connect with PC and execute local control of the ATS PDU.
- C. Source Indicator
Indicates Source A or B is in use. When both sources are normal, selected source shows constant green LED while another source shows blinking green LED.
- D. Output Indicator
Indicates load condition of the ATS PDU.
- E. Multifunction LCD Readout
Displays various ATS PDU information such as power and load conditions.
- F. Select Button
Use to control the LCD screen and toggle through the available informational options.
- G. Enter Button
Use to choose selected items, enter to next level menu or return to previous menu.
- H. AC Inlet/AC Power Cord
Use to connect ATS PDU to utility power or UPS.
- I. AC Output Receptacles
Provides power distribution for connected equipment.
- J. Outlet Indicator (switched series only)
When the LED is on, the outlet is providing power to connected equipment.
- K. Circuit Breaker
Provides output overload protection.
- L. Ground Stud
Use to ground the ATS PDU.

Technical Specifications

	Switched Series	Metered Series
Model Name	PDU32SWHVCEE18ATNET	PDU32MHVCEE18AT
Input		
Nominal Voltage	200-240V	
Frequency	50/60Hz	
Max. Input Current	32A	
Plug Type	(2) IEC 309 32A	
Power Cord Type	SR (10 AWG)	
Power Cord Length	10 ft/3.05 m	
Output		
Nominal Voltage	200-240V	
Derated Output Current	C13: 10A C19: 16A	
Derated Output Current (each bank)	20A	
Bank Number	2	
Outlet Type	(16) IEC C13 (2) IEC C19	
Outlet Number	18	
Circuit Breaker	Yes	
Transfer Time	Typical: 8-12ms 16ms max @ 60Hz/ 18ms max @ 50Hz	
Management and Communications		
Multifunction LCD Readout	Voltage, Frequency, Load, Current, HW/FW Version, Network Information	
Software	PowerPanel® Business Edition	
SNMP/ HTTP Capable	Yes, with RMCARD	Yes, with optional RMCARD
Connectivity	RJ45 (Serial Port)	
Sensor Capable	Optional	
Physical		
Dimension (W x H x D)	17.05" x 3.5" x 9.3"/433mm x 88mm x 236mm	
Environmental		
Humidity	0 to 95% Non-condensing	
Altitude	13100 ft/4000 m	
Temperature	32°F to 113°F/0°C to 45°C	
Safety Approvals		
Certifications	CE, FCC Class A	

* All specifications are subject to change without notice.

Installation Guide

ATS PDU Configuration

WARNING: This automatic transfer switch has dual power cords (A & B) to provide redundant power sources to devices with single power supplies and can be plugged into separate compatible sources* to ensure continuous access. Users select the preferred source as the primary input. CyberPower Smart App Online and Sinewave series UPS are highly recommended for use as the power source.

***Note:** Only sine wave AC power sources are compatible with this ATS PDU. Simulated sine wave AC power sources are NOT compatible.

Best Configuration

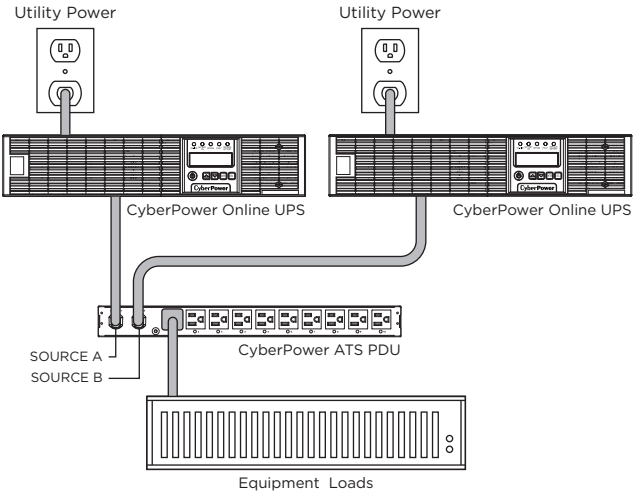

Minimum Acceptable Configuration

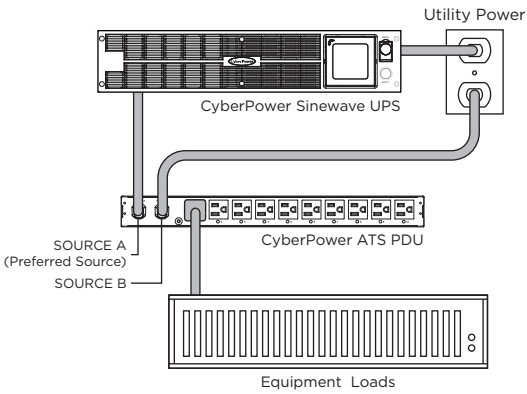

Installation Guide

CAUTION!! Please only use the provided screws for the entire installation process.

Front Mounting

For 1U Models

Step 1. Mounting Bracket Installation

Use the provided Mounting Bracket Screws (16) to attach the Mounting Brackets (2) to the ATS PDU.

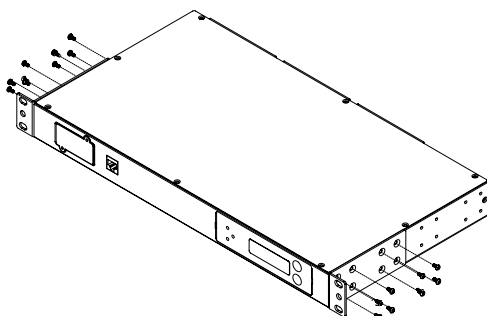

Step 2. Cord Retention Tray Installation (optional)

Adjust the length of the Cord Retention Tray till the screw hole on the Tray and ATS PDU are aligned. Attach the Cord Retention Tray to the ATS PDU with the 4 supplied Cord Retention Tray Mounting Screws. Tighten the Cord Retention Tray with the screw on it.

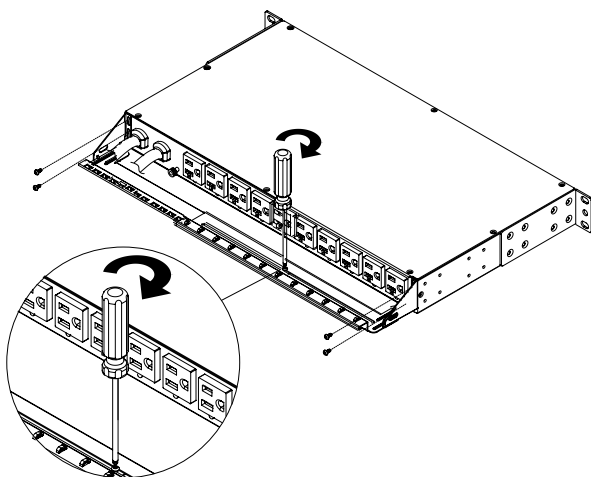

Step 3. ATS PDU Mounting

Use the provided Washers (4) and Screws (4) to secure the ATS PDU to your existing rack system.

Note: You may also use the screw sets provided by the rack to secure the ATS PDU.

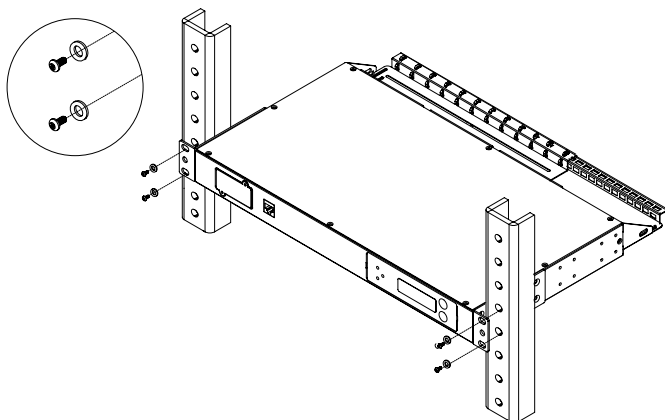

Installation Guide

Front Mounting

Step 4. Cable Ties (Optional)

Use the provided Cable Ties to fasten each cord to the Cord Retention Tray.

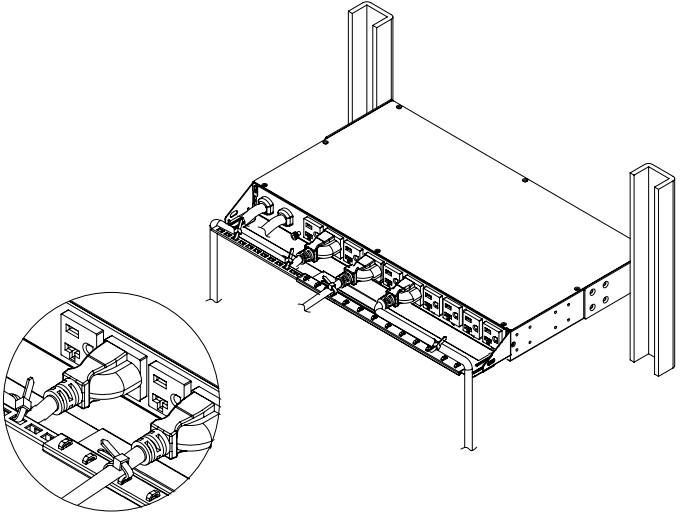

For 2U Models

Step 1. Mounting Bracket Installation

Use the provided Mounting Bracket Screws (16) to attach the Mounting Brackets (2) to the ATS PDU.

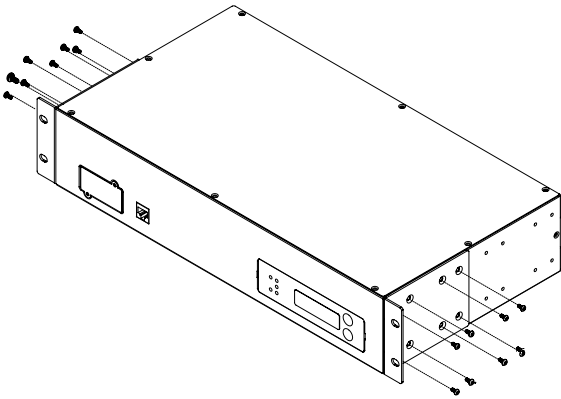

Step 2. Cord Retention Tray Installation (optional)

Adjust the length of the Cord Retention Trays till the screw hole on the Trays and ATS PDU are aligned. Attach the Cord Retention Trays to the ATS PDU with the 8 supplied Cord Retention Tray Mounting Screws. Tighten the Cord Retention Trays with the screw on it.

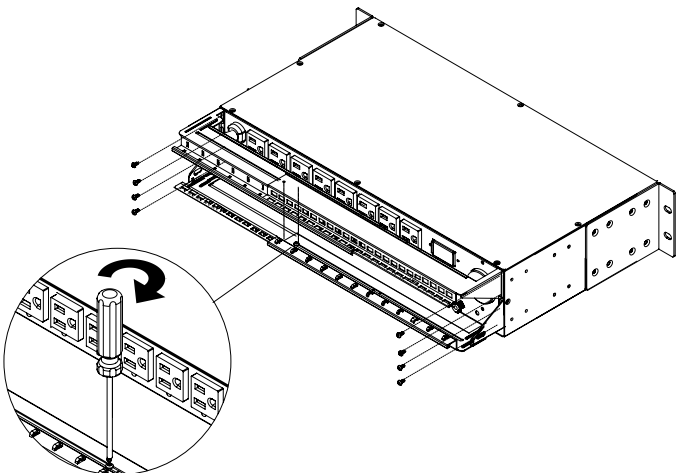

Installation Guide

Front Mounting

Step 3. ATS PDU Mounting

Use the provided Washers (4) and Screws (4) to secure the ATS PDU to your existing rack system.

Note: You may also use the screw sets provided by the rack to secure the ATS PDU.

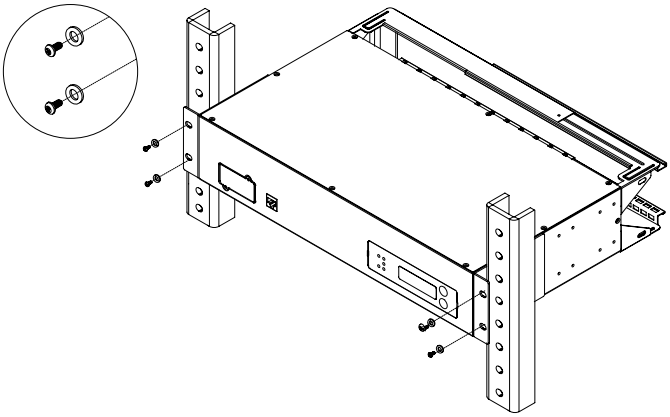

Step 4. Cable Ties (Optional)

Use the provided Cable Ties to fasten each cord to the Cord Retention Tray.

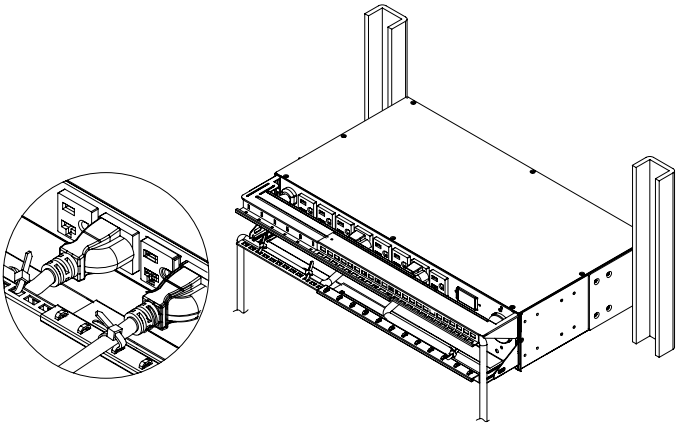

Rear Mounting

For 1U Models

Step 1. Mounting Bracket Installation

Use the provided Mounting Bracket Screws (16) to attach the Mounting Brackets (2) to the ATS PDU.

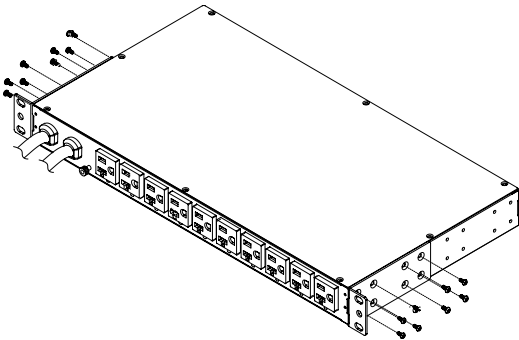

Installation Guide

Rear Mounting

If you plan on attaching the Cord Retention Tray to the ATS PDU, use the provided Mounting Bracket Screws (8) to attach the Mounting Brackets (2) to the ATS PDU.

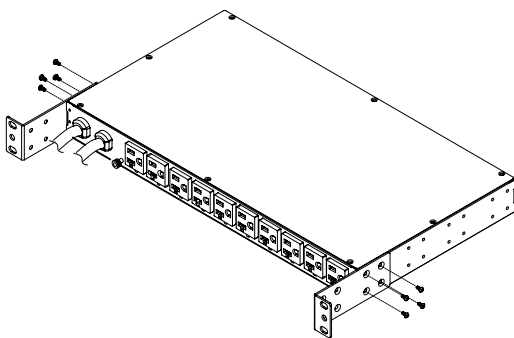

Step 2. Cord Retention Tray Installation (optional)

Adjust the length of the Cord Retention Tray till the screw hole on the Tray and ATS PDU are aligned. Attach the Cord Retention Tray to the ATS PDU with the 4 supplied Cord Retention Tray Mounting Screws. Tighten the Cord Retention Tray with the screw on it.

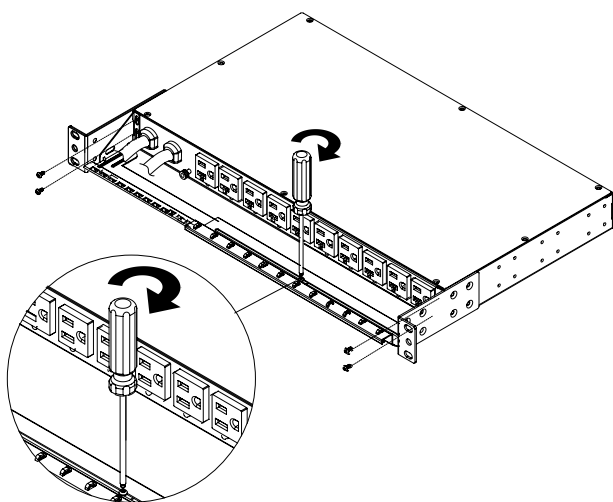

Step 3. ATS PDU Mounting

Use the provided Washers (4) and Screws (4) to secure the ATS PDU to your existing rack system.

Note: You may also use the screw sets provided by the rack to secure the ATS PDU.

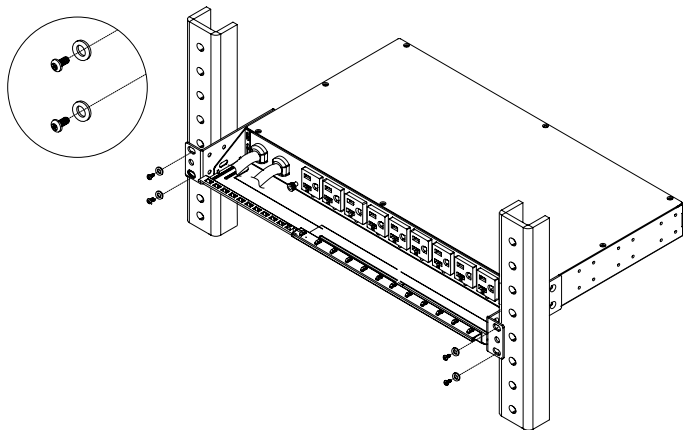

Installation Guide

Rear Mounting

Step 4. Cable Ties (Optional)

Use the provided Cable Ties to fasten each cord to the Cord Retention Tray.

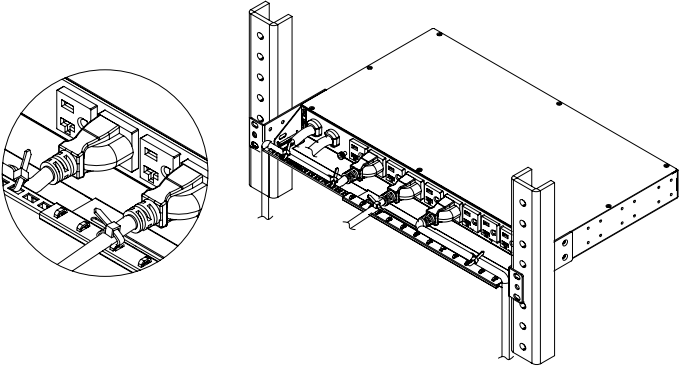

For 2U Models

Step 1. Mounting Bracket Installation

Use the provided Mounting Bracket Screws (16) to attach the Mounting Brackets (2) to the ATS PDU.

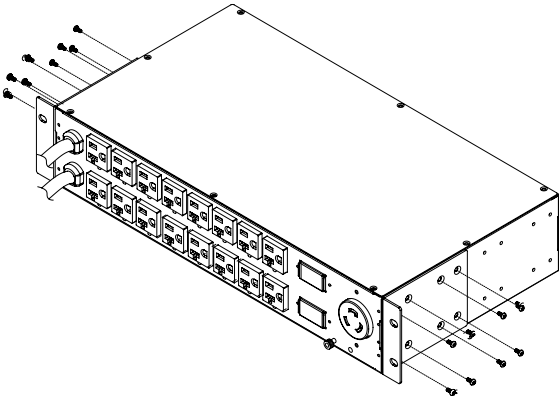

If you plan on attaching the Cord Retention Tray to the ATS PDU, use the provided Mounting Bracket Screws (8) to attach the Mounting Brackets (2) to the ATS PDU.

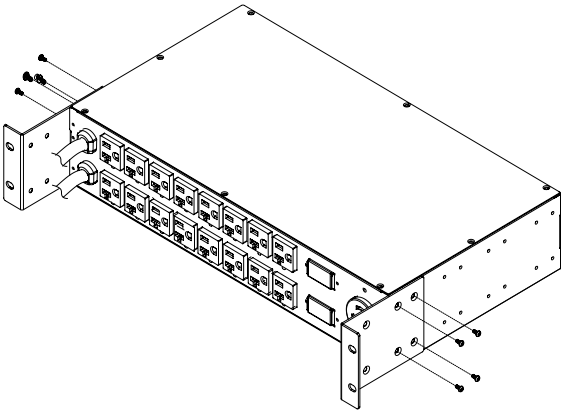

Installation Guide

Rear Mounting

Step 2. Cord Retention Tray Installation (optional)

Adjust the length of the Cord Retention Trays till the screw hole on the Trays and ATS PDU are aligned. Attach the Cord Retention Trays to the ATS PDU with the 8 supplied Cord Retention Tray Mounting Screws. Tighten the Cord Retention Trays with the screw on it.

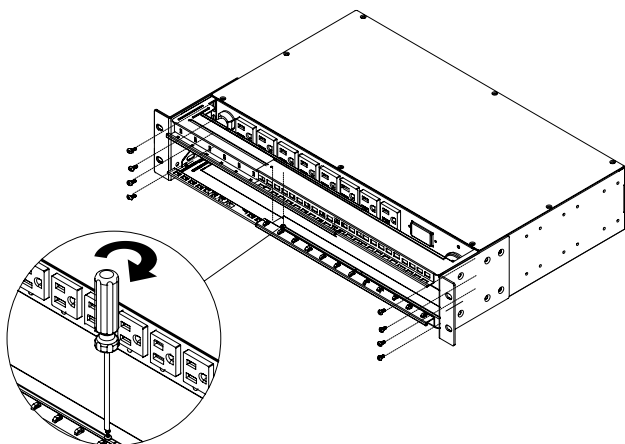

Step 3. ATS PDU Mounting

Use the provided Washers (4) and Screws (4) to secure the ATS PDU to your existing rack system.

Note: You may also use the screw sets provided by the rack to secure the ATS PDU.

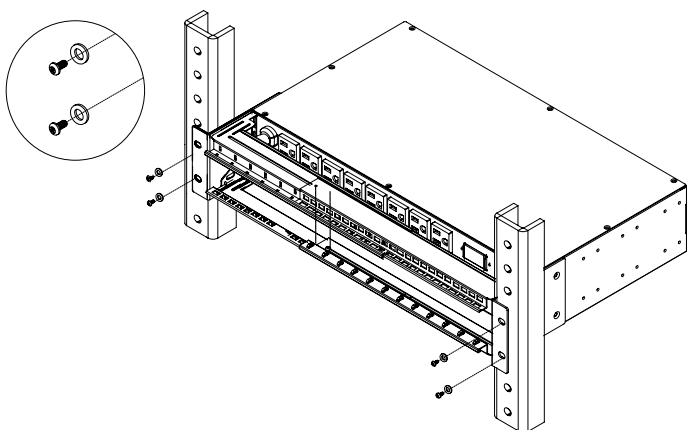

Step 4. Cable Ties (Optional)

Use the provided Cable Ties to fasten each cord to the Cord Retention Tray.

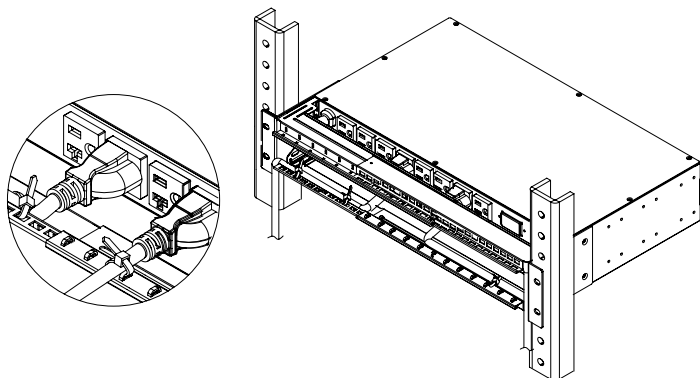

Installation Guide

Replacing the LCD Panel

Step 1. Use a slotted screwdriver to gently lift out the LCD panel.

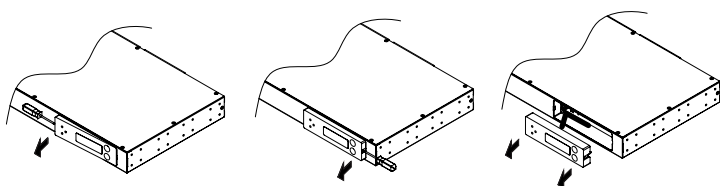

Step 2. Disconnect the cable connector.

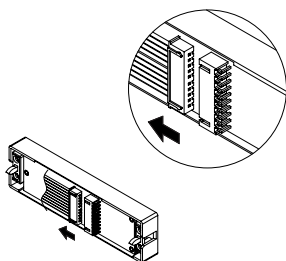

Electrical Installation

Step 1. Receptacle evaluation

Ensure that the plug type of your ATS PDU unit matches the receptacles that you are using.



The ATS PDU must be plugged into a three-wire, grounded utility receptacle or a UPS that is connected to a grounded utility receptacle. The utility receptacle must also be connected to an appropriate branch circuit/main with fuse or circuit breaker protection. Connection to any other type of receptacle may result in an electrocution hazard.

Step 2. Plug the ATS PDU into the utility receptacle and/or UPS.

For configuration details, refer to ATS PDU Configuration on page 8.

Step 3. Attach equipment

It is extremely important not to exceed the ATS PDU's maximum current load (as outlined in the Specifications section). In order to determine total load, use the LCD screen on the front of the ATS PDU to monitor the load being attached.

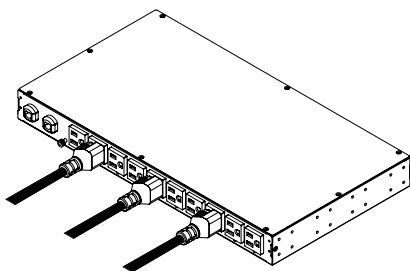

Installation Guide

Power Cord Locking - For IEC Type ATS PDU

Input Power Cord

Step 1. Align and insert the Cable Tie from the upper side of the Fixed Stand and fasten it as shown below.

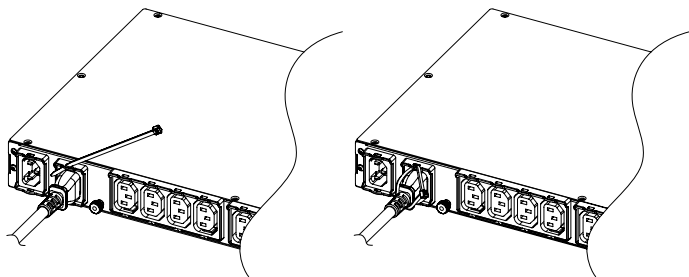

Step 2. Align and insert the Cable Tie from the bottom side of the Fixed Stand and fasten it as shown below.

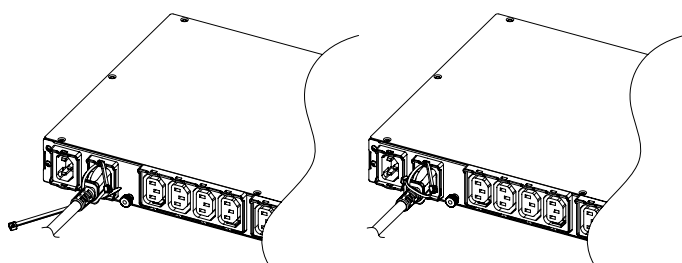

Output Power Cord

Step 1. Align and insert the Cable Tie from the upper side of the Fixed Stand and fasten it as shown below.

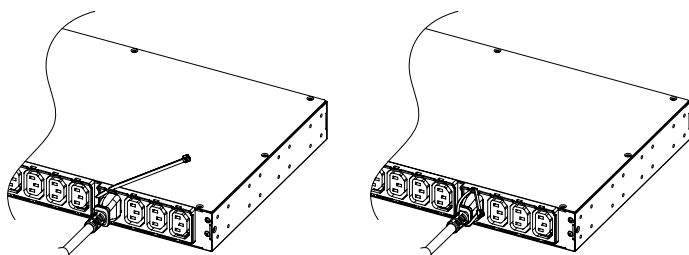

Operation

Remote Management

The remote management function via the RMCARD205 provides for monitoring of the ATS PDU operational information, controlling outlets and utilizing SNMP functionality.

Web

Remote management can be performed via web interface. To access the web interface, please follow the instructions below:

1. Enter the IP address of the ATS PDU into a web browser.
2. Enter the user name and password of the ATS PDU device at the authentication screen.

Note: The default username is “**cyber**” and the default password is “**cyber**”.

Telnet and SSH

The CyberPower ATS PDU provides Telnet and Secure Shell (SSH) as Remote Management methods. Telnet uses user name and password as basic security while SSH has a higher security level with encryption of the transmitted packets including user name, password, and data. Configure the Setting of Telnet and SSH on the Web Interface. The default user name and password is **cyber/cyber**.

Note: When user logs in with the admin username and admin password through Telnet or SSH, there are two types of interfaces available. One is the command line interface (CLI) and the other is a menu interface. The default is CLI. If the user wants to change to the menu interface, type in the [menumode] command. To switch back to CLI, it is necessary to logout and login to the RMCARD.

SNMP

The CyberPower ATS PDU supports SNMPv1 and SNMPv3 protocols. Download the CyberPower MIB file and add it to a SNMP-supported management software. Default read/write community is public/private for SNMPv1. SNMPv3 provides a higher security level than SNMPv1 by encrypting the transmitted packet. Configure the settings of the SNMPv1/SNMPv3 on Web Interface. For more details, please see the RMCARD205 User Manual.

Local Management

LCD Operation

The LCD screen provides instant information, such as source condition, voltage and current, for the ATS PDU. In addition, users can use the interface to configure each PDU parameters and control each outlet on the switched ATS PDU.

A. Scroll Mode: The ATS PDU information will display in following order automatically when “Scroll Mode On” is configured.

Source A information
Source B information
Device Load
Bank 1 Current (2U series)
Bank 2 Current (2U series)
Bank 3 Current (2U series)
Environment Status (Displays when the ENVIROSENSOR is connected)

B. Main Menu Map

About	Hardware Version
	Firmware Version
	Network Information
	Serial Number

Settings	Preferred Source	A/B/None			
	Source Configuration	Nominal Voltage			
		Voltage Range			
		Freq. Deviation			
		Sensitivity			
	Load Configuration	Device Bank/1/2/3	Overload Threshold		
			Near Overload Threshold		
			Low Load Threshold		
	Outlet Control	Device Bank/1/2/3	All/Outlet 1-N	Immediate On	
				Delay On	
				Immediate Off	
				Delay Off	
				Reboot	
LCD Settings	Brightness	Screen Off	Delay Reboot		
			Scroll Mode		
			Screen Off		

Operation

Local Management

Reset/Reboot	Reset All (ATS PDU, RMCARD and LCD)
	Reset Except TCP/IP
	Reset Account (User Name and Password)
	Reboot

LED Indicators

Indicator	Status	Description
Source	Solid Green	Selected source and power condition is normal.
	Flashing Green	Backup source and power condition is normal.
	Orange	Power condition is abnormal.
Load	Green	The aggregate current of each bank is normal.
	Orange	Near overload.
	Red	Overload.
Tx/Rx	Off	The ATS PDU power is off.
	On (Green)	The ATS PDU power is on.
	Flashing	Receiving/transmitting data packet. Reset finished.
LINK	On	Indicates the ATS PDU is connected to the LAN.
	Off	Indicates the ATS PDU is not connected to the LAN.
Outlet	On	The outlet is on and providing power.
	Off	The outlet is off.

Environmental Monitoring (optional)

The CyberPower ATS PDU with an environmental sensor (ENVIROSENSOR) installed, provides remote temperature and humidity monitoring in a server closet and/or datacenter. To connect ATS PDU with ENVIROSENSOR, use RJ45 Ethernet Cable included with the ENVIROSENSOR. Plug one end into the Universal port on the RMCARD205 and the other end into the RJ45 port on the ENVIROSENSOR (as shown in figures below). When the ATS PDU connected correctly to the ENVIROSENSOR, users can see the temperature and humidity data via the Web Interface.

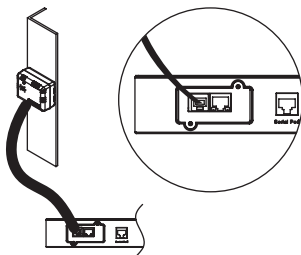

Device Reset

- To reset all the settings to default locally, use Reset function in the LCD screen.
- To reset all the settings to default remotely, log in Web interface, enter the Reset page and apply the function.

Unattended/Automatic Shutdown

PowerPanel Business Edition software automatically initiates a graceful shutdown on the connected computer's operating system in an orderly fashion.

PowerPanel must be installed on every computer or server for which the shutdown is to take place. The computer will receive a device status message from the RMCARD205 and will perform the shutdown according to the instructions provided, including shutdowns at exact times and dates.

Follow the directions below for setting up Unattended/Automatic Shutdown.

Step 1. Computer Configuration

1. Install PowerPanel Business Edition Client on every computer/server that will be part of the shutdown process (Follow the instructions in the PowerPanel Business Edition Client User Manual).
2. Configure the settings in PowerPanel Business Edition Client. See the PowerPanel Business Edition Client User Manual for detailed instructions.

Step 2. ATS PDU Network Configuration

Verify that the IP address of all computers, that will be part of the shutdown process, are included in the Client List of the web interface (Follow the instructions in the PowerPanel Business Edition User Manual).

Step 3. Notification

Notifying the computers of potential outlet shutdowns can be accomplished using the following functions:

- Outlets Control Menu: Performing the task of turning off or rebooting outlets
- Scheduling Menu: Setting the application to perform the task of turning off or rebooting outlets. The notification will occur prior to the scheduled date/time.
- Outlet Overload: In the event of ATS PDU overload, notification will be sent prior to the ATS PDU shutting down.

Firmware Upgrade

By upgrading the Firmware, you can obtain new features, updates and improvements to existing functionality. To ensure the firmware is kept up to date, please regularly visit our website to see if there is any updated firmware version available.

Note: Please do not turn the ATS PDU off when processing the firmware upgrade. ATS PDU outlets will remain powered on while the firmware update takes place. Only the ATS PDU LCD screen will reboot.

ATS PDU

Update the following file to upgrade the firmware.

- cpsatsmaf_w_xxx.bin

Note that the XXX is not part of the file name but is where the version number in the filename is given.

Use the following steps to upgrade the firmware.

1. Download the latest firmware from www.cyberpower.com.
2. Extract the file to "C:\".
3. Open Hyper Terminal to connect the ATS PDU and use the command "@NEW".

Note: In order for Hyper Terminal to interact with the ATS PDU, the PC/server must be connected directly to the ATS PDU via the serial port.

- (1). Use the included RJ45/DB9 serial port connection cable. Attach one end to the serial port on the front of the ATS PDU, and the other end to the PC/server.
- (2). Open the Hyper Terminal software on your PC and select a name and icon for the connection.
- (3). Setup the COM port settings using the following values.
 - * Bits per second: 38400
 - * Data bits: 8
 - * Parity: None
 - * Stop bits: 1
 - * Flow control: None

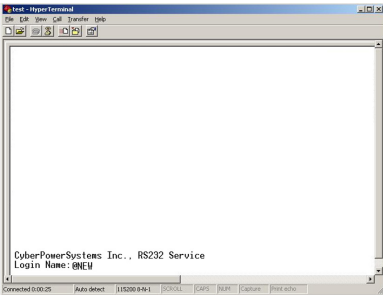

4. The ATS PDU will reboot and show main menu on Hyper Terminal.

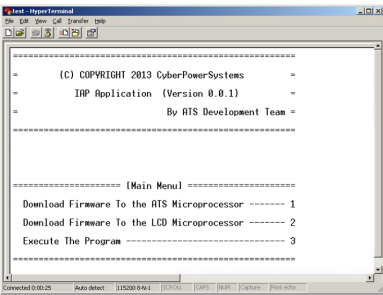

5. Press "1" to select ATS PDU upgrade.

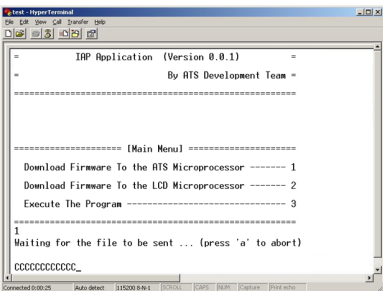

Firmware Upgrade

6. Select Transfer > Send File.

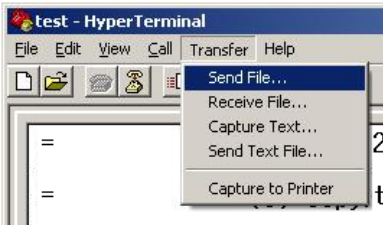

7. Note that the Ymodem protocol and file "C:\cpsatsmaf_w_xxx.bin" are selected in Hyper Terminal.

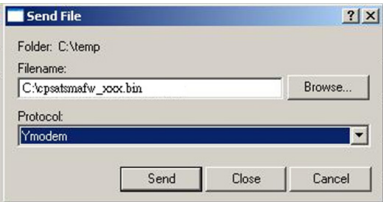

8. The download progress window will open after you click the Send button.

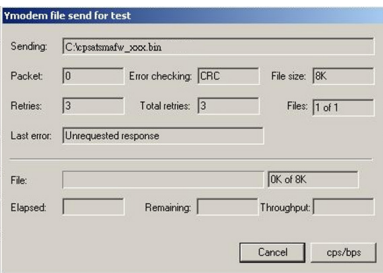

9. After uploading the binary file Hyper Terminal will show as below.

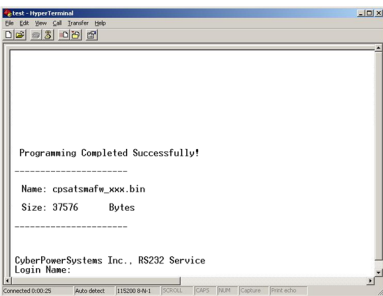

LCD

Update the following file to upgrade the firmware.

- cpsatslafw_xxx.bin

Note that the XXX is not part of the file name but is where the version number in the filename is given.

Use the following steps to upgrade the firmware.

1. Download the latest firmware from www.cyberpower.com.
2. Extract the file to "C:\".
3. Open Hyper Terminal to connect the ATS PDU and use the command "@NEW".

Note: In order for Hyper Terminal to interact with the ATS PDU, the PC/server must be connected directly to the ATS PDU via the serial port.

- (1). Use the included RJ45/DB9 serial port connection cable. Attach one end to the serial port on the front of the ATS PDU, and the other end to the PC/server.
- (2). Open the Hyper Terminal software on your PC and select a name and icon for the connection.
- (3). Setup the COM port settings using the following values.
 - * Bits per second: 38400
 - * Data bits: 8
 - * Parity: None
 - * Stop bits: 1
 - * Flow control: None

Firmware Upgrade

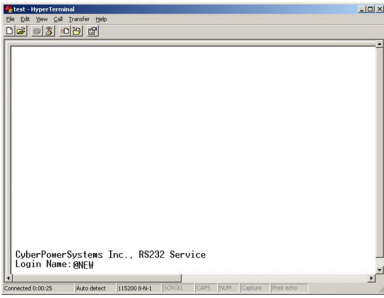

4. The ATS PDU will reboot and show main menu on Hyper Terminal.

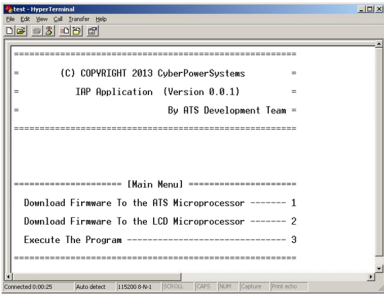

5. Press "2" to select LCD upgrade.

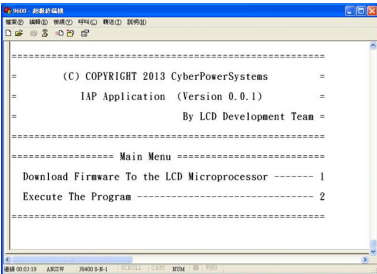

6. Press "1".

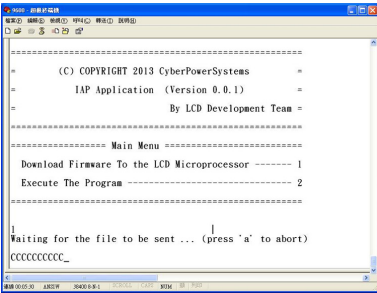

7. Select Transfer > Send File.



8. Note that the Ymodem protocol and file "C:\cpsatslafw_XXX.bin" are selected in Hyper Terminal.

Firmware Upgrade

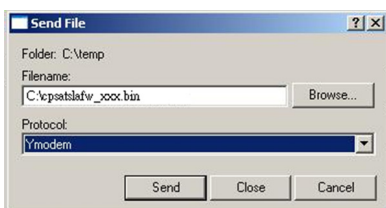

9 The download progress window will open after you click the Send button.

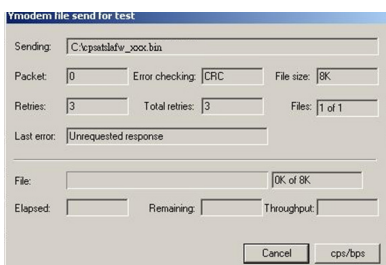

10. After uploading the binary file, Hyper Terminal will be shown as below.

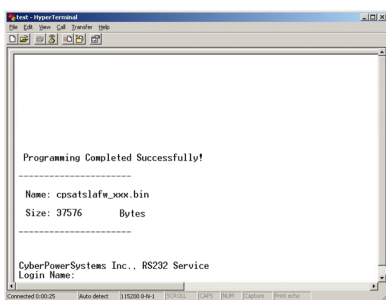

You can see if the firmware upgrade is successful by checking the “CyberPower System Firmware Version” after login.

- Note :**
1. Please do not turn the ATS PDU off and ensure the quality of selected source power when processing firmware upgrade. The ATS PDU will not perform the ATS function when upgrading firmware.
 2. Press “3” to exit the main menu of firmware upgrade.

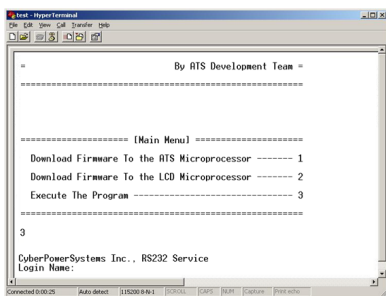

RMCARD

There are two files to update in order to upgrade the firmware:

- cpsrm2scfw_XXX.bin
- cpsrm2scdata_XXX.bin

Note that the XXX is not part of the file name but is where the version number in the filename is given.

Option 1: Using FTP Command

Use the following steps to upgrade the firmware.

1. Download the latest firmware.
2. Extract the downloaded files to “C:\”.
3. Open a command prompt window.
4. Login to the CyberPower Remote Management Card with FTP command, in the command prompt type:

Firmware Upgrade

- (1) ftp
- (2) ftp > open
- (3) To [current IP address of RMCARD] [port]; e.g., To 192.168.22.126 21
- (4) Input USER NAME and PASSWORD (same as the administrator account in web user interface)

5. Upload the cpsrm2scfw_XXX.bin, type:

```
ftp > bin
ftp > put cpsrm2scfw_XXX.bin
```

6. Upgrade is now complete, type:

```
ftp > quit
```

7. The system will reboot after you type “quit”.

8. Login to the FTP again as step 4.

9. Upload cpsrm2scdata_XXX.bin, type:

```
ftp > bin
ftp > put cpsrm2scdata_XXX.bin
```

10. Upgrade complete, type

```
ftp > quit
```

11. The system will reboot after you type “quit”.

Option 2: Using Upgrade and Configuration Utility Tool
(Bulk Firmware Upgrade Tool)

Use the following steps to upgrade the firmware.

1. Install the CyberPower Upgrade and Configuration Utility tool available for download at www.cyberpower.com.
2. After installation completes, run the “Upgrade and Configuration Utility”.
3. The main window of the Upgrade and Configuration Utility tool program is shown in below figure. The configuration tool will display all CyberPower Remote Management devices present on the local network subnet. The “Discover” button is used to search the local network subnet again.

Note: You can click “View” to select the items you want to view.

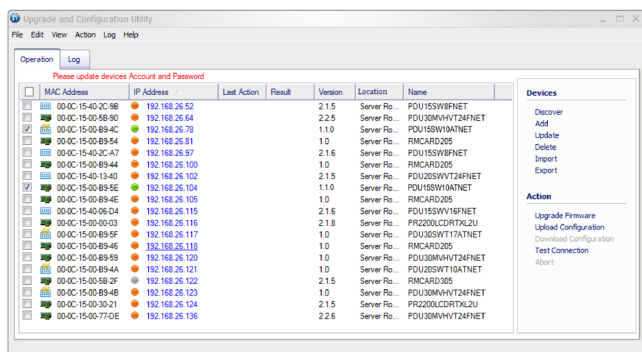

The main window of the “Upgrade and Configuration Utility” program

4. Check the boxes to select the devices you wish to upgrade, and select “Update” on the right to update the device user account and password. Once the update is confirmed, the status icon next to the IP Address will change from orange to green.

Note: You must update the device user account and password credentials before firmware upgrade.

5. Select the devices you wish to upgrade by checking their respective checkbox and select “Upgrade Firmware”.

Note: You can upgrade the firmware of multiple devices that use the same firmware files (Bulk firmware upgrade).

6. Select the Firmware and Data files and click “OK”, as shown in below figure.

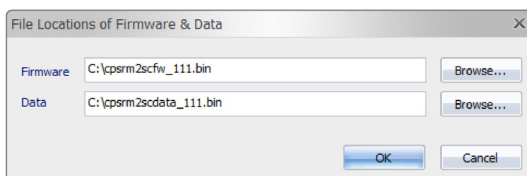

The File Locations of Firmware & Data window

7. Click “Yes” to start firmware upgrade on selected devices, as shown in below figure.

Firmware Upgrade

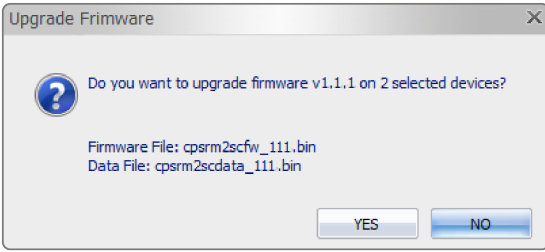

Confirm Upgrade Firmware message window

8. If the firmware upgrade is implemented, you will see the Result in the main window, as shown in below figure.

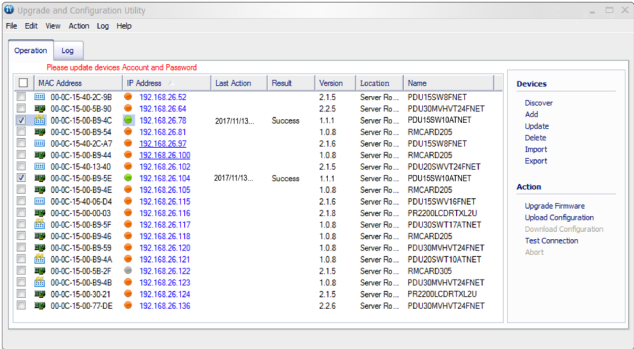

Firmware upgrade success in the main window

Troubleshooting

Problem	Possible Cause	Solution
ATS PDU outlets do not provide power to connected equipment	<ol style="list-style-type: none"> 1. Breaker tripped 2. Power cord is not properly plugged in 	Reset Breaker, check the plug to insure its connected correctly. If the problem remains, contact technical support.
Amperage displayed on LCD screen exceeds the units capability	Overload	The load indicator shows red when overload. Reduce the load on the ATS PDU until the overload is gone. If the problem remains, contact technical support.
Circuit breakers have tripped	<ol style="list-style-type: none"> 1. Sustained overload 2. Excessive ambient or internal temperatures 3. Faulty breaker 	Reset Breaker. If the problem remains, contact technical support.

Conformance Approvals

FCC Warning

WARNING!! This equipment has been tested and found to comply with the limits for a Class A Digital Device, pursuant to Part 15 of the FCC Rules. These limits are designed to provide reasonable protection against harmful interference in residential installation. This equipment generates, uses and can radiate radio frequency energy and, if not installed and used in accordance with the instruction manual, may cause harmful interference to radio communications. Operation of this equipment in a residential area is likely to cause harmful interference in which case the user will be required to correct the interference at their own expense.

Any special accessories needed for compliance must be specified in the instruction.

This device complies with part 15 of the FCC Rules. Operation is subject to the following two conditions: (1) This device may not cause harmful interference, and (2) this device must accept any interference received, including interference that may cause undesired operation.

Notice: (1) An unshielded-type power cord is required in order to meet FCC emission limits and also to prevent interference to the nearby radio and television reception. It is essential that only the supplied power cord is used. (2) Use only shielded cables to connect I/O devices to this equipment.

Note: THE MANUFACTURER IS NOT RESPONSIBLE FOR ANY RADIO OR TV INTERFERENCE CAUSED BY UNAUTHORIZED MODIFICATIONS TO THIS EQUIPMENT. SUCH MODIFICATIONS COULD VOID THE USER'S AUTHORITY TO OPERATE THE EQUIPMENT.

The Class A digital apparatus meets all requirements of the Canadian Interference-Causing Equipment Regulation.

Cet appareil numérique de la class A respecte toutes les exigences du Règlement sur le matériel brouilleur du Canada.

European Union

This is a class A product. In a domestic environment this product may cause radio interference in which case the user may be required to take adequate measures.

Customer Service & Warranty

Product Registration

Thank you for purchasing a CyberPower product. Prompt product registration entitles coverage under the Limited Warranty and also allows the opportunity to be notified of product enhancements, upgrades, and other announcements.

Registration is quick and easy at www.cyberpower.com/registration.

CyberPower International

Feel free to contact our Tech Support department with installation, troubleshooting, or general product questions.

Cyber Power Systems, Inc.
www.cyberpower.com

For USA and Canada:

4241 12th Ave East, Suite 400
Shakopee, MN 55379
Toll-free: (877) 297-6937

For all other regions:

Please visit our website for local contact information.

Customer Service & Warranty

Limited Warranty

Read the following terms and conditions carefully before using the CyberPower ATS PDU series. By using the Product, you consent to be bound by and become a party to the terms and conditions of this Limited Warranty. If you do not agree to the terms and conditions of this Warranty, you should return the Product for a full refund prior to using it.

Who Is Providing This Warranty?

Cyber Power Systems, Inc. provides this Limited Warranty.

What Does This Warranty Cover?

This warranty covers defects in materials and workmanship in the Product under normal use and conditions.

What Is The Period of Coverage?

For USA and Canada, CyberPower provides a 3-Year limited warranty to the original purchaser who owns the Product. For other regions, please contact your local CyberPower sales team for more information.

Who Is Covered?

This warranty only covers the original purchaser. Coverage ends if you sell or otherwise transfer the Product.

How Do You Get Service?

1. You can use the contact information mentioned above for instructions.
2. When you contact CyberPower, identify the Product, the Purchase Date, and the item(s) of Connected Equipment.
3. You must provide a purchase receipt (or other proof of the original purchase) and provide a description of the defect.

What Will We Do To Correct Problems?

CyberPower will inspect and examine the Product.

If the Product is defective in material or workmanship, CyberPower will repair or replace it at CyberPower's expense, or, if CyberPower is unable to or decides not to repair or replace the Product (if defective) within a reasonable time, CyberPower will refund to you the full purchase price you paid for the Product (purchase receipt showing price paid is required).

Who Pays for Shipping?

We pay when we send items to you; you pay when you send items to us.

What Are Some Things This Warranty Does Not Cover?

1. This Warranty does not cover any software that is damaged or needs to be replaced due to the failure of the Product or any data that is lost as a result of the failure or the restoration of data or records, or the reinstallation of software.
2. This Warranty does not cover or apply to: misuse, modification, operation or storage outside environmental limits of the Product or the equipment connected to it, nor for damage while in transit or in storage, nor if there has been improper operation or maintenance, or use with items not designed or intended for use with the Product, such as laser printers, appliances, aquariums, medical or life support devices, etc.

What Are The Limitations?

1. This Warranty does not apply unless the Product and the equipment that was connected to it were connected to properly wired and grounded outlets (including compliance with electrical and safety codes of the most current electrical code), without the use of any adapters or other connectors.
2. The Product must have been plugged directly into the power source and the equipment connected to the Product must be directly connected to the Product and not "daisy-chained" together in serial fashion with any extension cords, another Product or device similar to the Product, surge suppressor, or power tap. Any such installation voids the Limited Warranty.
3. The Product and equipment connected to it must have been used properly in a suitable and proper environment and in conformance with any license, instruction manual, or warnings provided with the Product and the equipment connected to it.
4. The Product must have been used at all times within the limitations on the Product's VA capacity.
5. The sole and exclusive remedies of the Initial Customer are those provided by this Warranty

Appendix A-Hyper Terminal

Hyper Terminal software can be used for basic ATS PDU configuration. In order for Hyper Terminal to interact with the ATS PDU, the PC/server must be connected directly to the ATS PDU via the serial port with the included RJ45/DB9 serial port connection cable. It utilizes a text-based interface and menu system. Navigation through the interface is done by typing the number of the menu option and pressing the Enter key. Setup the COM port settings using the following values.

- * Bits per second: 38400
- * Data bits: 8
- * Parity: None
- * Stop bits: 1
- * Flow control: None

Note: The session will timeout and logout after 3 minutes of inactivity. Menu options are shown below:

[Main Menu]

1. Utility Configuration
2. Outlet Manager (Switched Series Only)
3. Load Configuration
4. Network Settings
5. System Configuration
6. Account Settings
7. Configure System to Default
8. Logout

[Utility Configuration]

1. Preferred Source: A
2. Sensitivity: High
3. Voltage Range: Medium
4. Frequency Deviation: 1 Hz
5. Nominal Voltage: 230 V
6. Wide Voltage Range: 30 V
7. Medium Voltage Range: 23 V
8. Narrow Voltage Range: 16 V
9. Set Load Restriction (Switched Series Only)

[Outlet Manager]

1. Outlet Control
2. Outlet Configuration

[Load Configuration]

1. Device Threshold Configuration
2. Bank 1 Threshold Configuration
3. Bank 2 Threshold Configuration
4. Bank 3 Threshold Configuration

[Network Setting]

Physical MAC Address: 00-0C-15-00-00-01

1. System IP: 192.168.20.240
2. Subnet Mask: 255.255.255.0
3. Default Gateway: 192.168.20.254
4. DHCP: Enabled
5. Http Port: 80
6. Http Access: Enabled

[System Configuration]

1. Name: PDU15SW10ATNET
2. Location: Server Room
3. Contact: Administrator

[Account Setting]

1. Administrator

[Configure System to Default]

Sure to Configure System to Default

1. Reset ATS PDU
2. Reset ATS PDU (TCP/IP Settings Reserved)

Appendix B-Power Device Network Utility

Overview

The CyberPower Power Device Network Utility is an easy-to-use interface which is used for establishing IP addresses on CyberPower ATS PDUs.

Installation

Step 1. Download the Power Device Network Utility software available at www.cyberpower.com.

Step 2. Select **Next** in the software wizard (Shown in Figure 1).



Figure 1

Step 3. Choose an installation directory. Select **Next** (Shown in Figure 2).

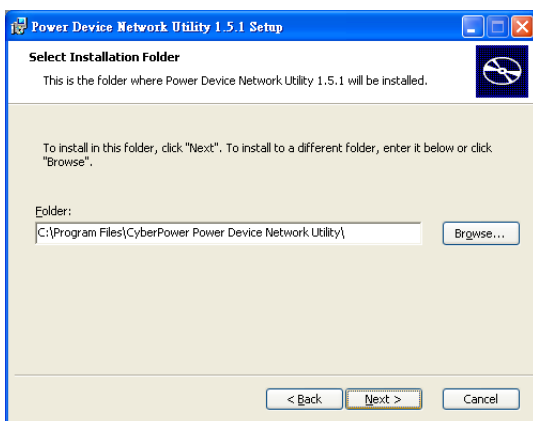

Figure 2

Step 4. Select **Install** to confirm the settings and install (Shown in Figure 3).

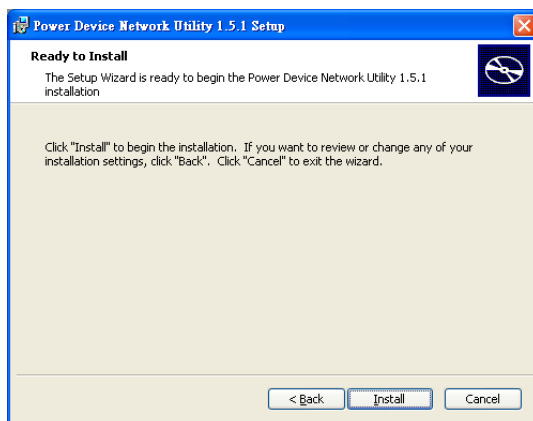

Figure 3

Appendix B-Power Device Network Utility

Step 5. Select **Finish** to finalize the installation (Shown in Figure 4).



Figure 4

Launch Program

To launch the Power Device Network Utility and get started, select Programs from the Start menu in Windows and locate the new folder and icons for Power Device Network Utility. Select Power Device Network Utility from the program folder (Shown in Figure 5).

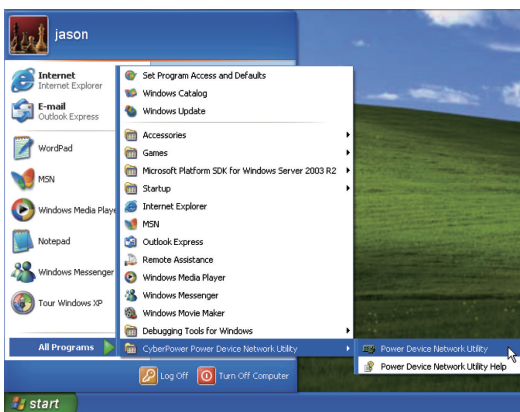

Figure 5. Power Device Network Utility

Getting Started

The Power Device Network Utility scans the network for devices with MAC addresses that match CyberPower network hardware. Once found, the device(s) can then be figured with a specific IP address, subnet mask, and gateway address. This allows the device(s) to function properly on the network and interface with CyberPower Management Console.

Step 1. Select the appropriate ATS PDU from the Equipment List (Shown in Figure 6).

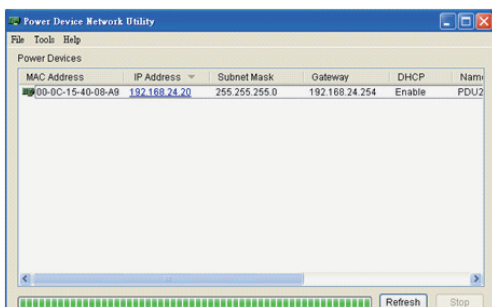

Figure 6. Equipment List

Note: If the ATS PDU does not appear on the list, click the Refresh button to rescan the network. If it still does not appear, ensure that the ATS PDU is turned on and is installed correctly. Pressing Stop will cancel the scan/refresh process.

Note: If your computer has a software firewall installed, you may see a Windows Security Alert message (Shown in Figure 7).

In Windows XP SP2, the default firewall alert message is shown as Figure 7. You need to allow the Power Device Network Utility access through the firewall.

Appendix B-Power Device Network Utility



Figure 7. Windows Security Alert

Step 2. Assign a valid IP Address to the ATS PDU.

With the appropriate device selected from the Equipment List, open the Network Settings menu (shown in Figure 8) [Tools=>Device Setup]. In the Device Network Setting Menu, enter a valid IP address, subnet mask, and gateway address to setup the ATS PDU device.



Figure 8. Network Setting Menu (Device Setup)

Step 3. Authentication

Enter the user name and password of the ATS PDU at the Authentication menu (shown in Figure 9).

Note: The default username is "cyber" and the default password is "cyber".

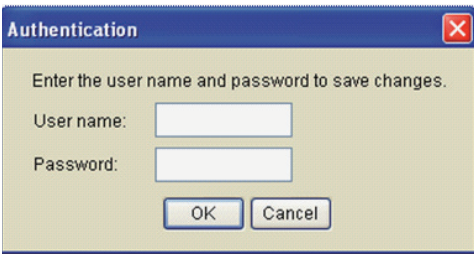

Figure 9. Authentication screen

Advanced Settings

Timeout Settings

The Timeout Setting (Shown in Figure 10). [Edit=>Timeout Settings] is used to specify the wait time when scanning for network ATS PDUs. When there are many devices on the local network, it may take extended periods of time to locate all the devices. The timeout function is used to limit the search time. The default setting is 3 seconds. Valid values are 3 to 60 seconds.

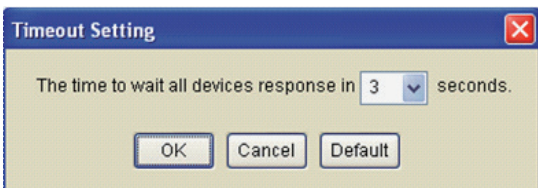

Figure 10. Timeout Setting



CyberPower

Cyber Power Systems, Inc.
www.cyberpower.com