

GIBRALTAR

SPECIFICATIONS

WEATHER VENT™

#63000

26 Gauge Galvanized Steel • Off Ridge Vent • N.F.V.: 104 sq. in. • Rough Opening: 2½ in. x 42 in. • Patent 7,044,852

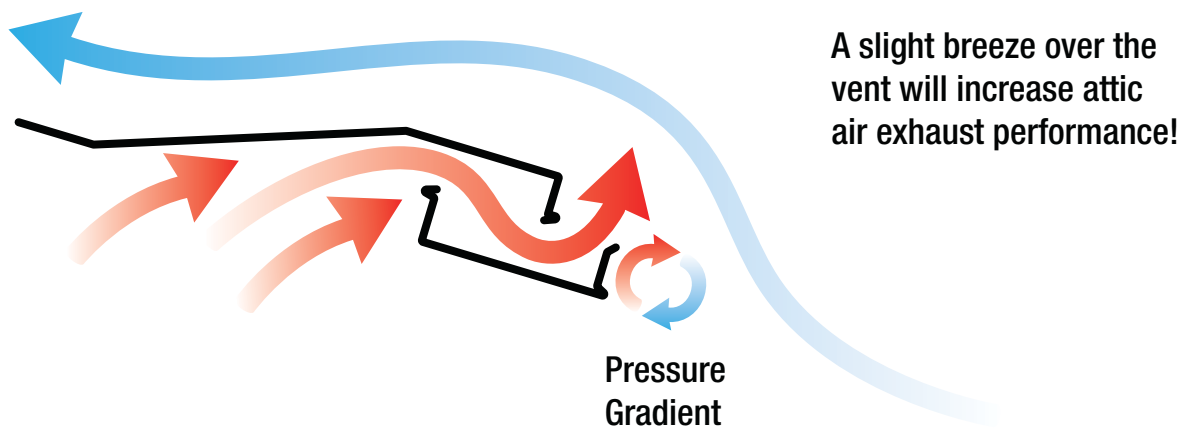
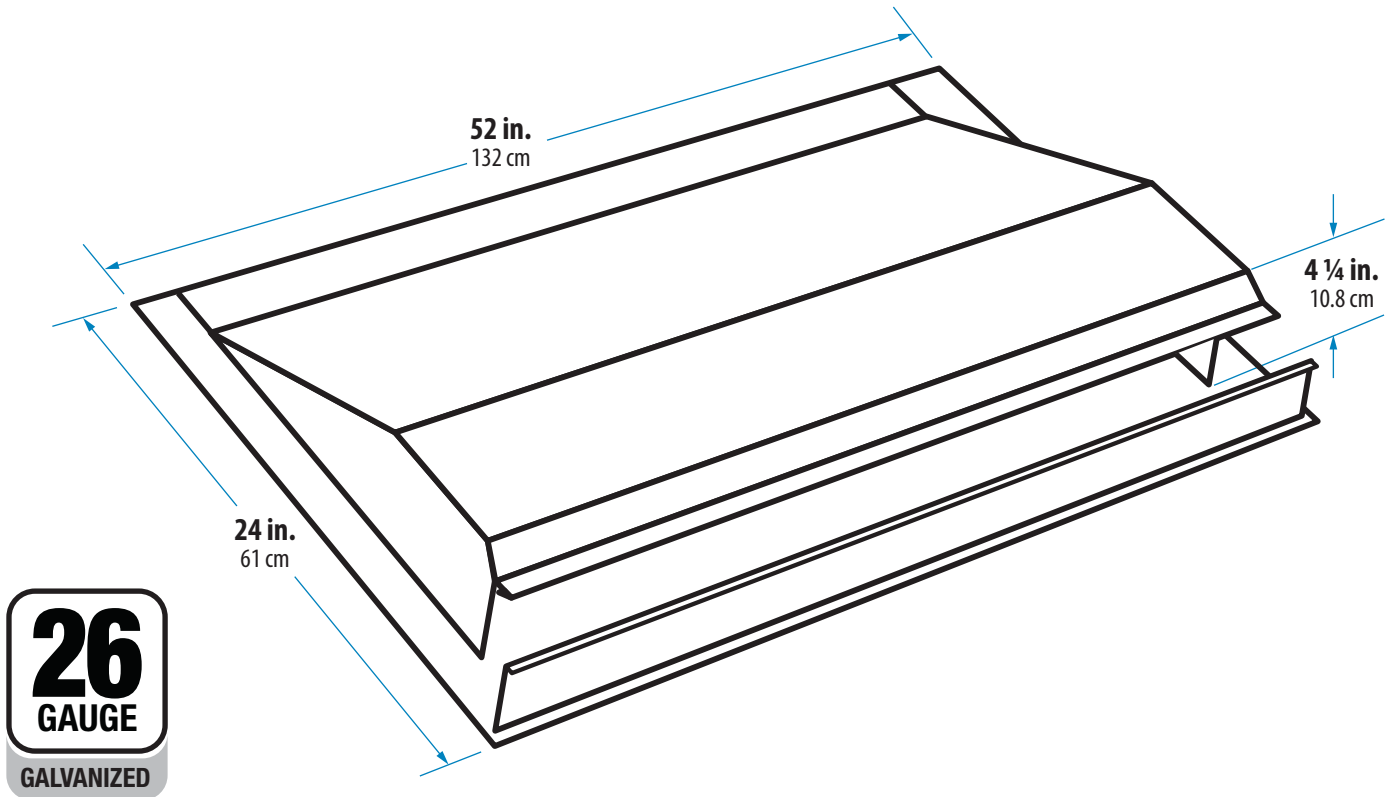

Code Approvals¹

UL Fire Resistant Directory #R20735
Florida Building #FL-16994.2
Miami Dade #: NOA No.: 18-1212.10

Testing Data & Specifications

Accelerated Testing 2000 hours - ASTM G23
Salt Spray Testing 1000 hours - ASTM B117
Fire Testing - ASTM E108 or UL 790
Wind Driven Rain - TAS 100

1. Code Approval numbers may have changed since publication. For the most recent code approval numbers, contact our Technical Department or refer to the appropriate code agency.