

Technical Instructions

Description ■

The HydroGuard® XP SH1430 and LFSH1430 series is a temperature actuated mixing valve designed for use in hot water distribution systems, in compliance with ASSE 1017.

Specifications ■

- Maximum Operating Pressure 125 psi (861 kPa)
- Maximum Hot Water Temperature 200°F (93°C)
- Minimum Hot Water Supply Temp. 5°F (3°C) Above Set-Point*
- Hot Water Inlet Temperature Range 120 -180°F (49 - 82°C)
- Cold Water Inlet Temperature Range 40 - 80°F (4 - 27°C)
- Temp. Adjustment Ranges **Standard: 90 - 160°F (32 - 71°C)
Low: 60 - 90°F (16 - 32°C)
- Listing ASSE 1017
- Certified CSA B125

* With Equal Pressure

** **NOTE:** Low limit cannot be less than the cold water temperature. For best operation, hot water should be at least 5°F (3°C) above desired set point.

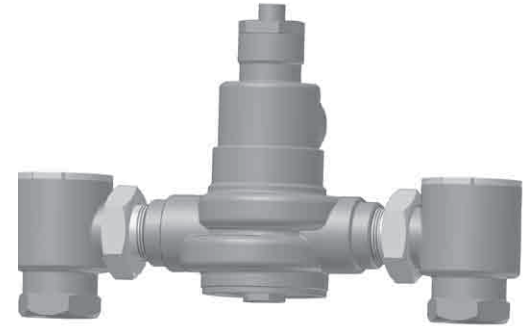

Advanced Thermal Actuation

⚠ WARNING

You are required to thoroughly read all installation instructions and product safety information before beginning the installation of this product. Powers is not responsible for damages resulting from improper installation and/or maintenance.

Local building or plumbing codes may require modifications to the information provided. You are required to consult the local building and plumbing codes prior to installation. If this information is not consistent with local building or plumbing codes, the local codes should be followed.

Capacity ■

Capacity Table, presents the HydroGuard discharge capacity in gpm and lpm for various pressure drops across the valves (the difference between the lowest inlet pressure and the discharge pressure at the HydroGuard.)

⚠ WARNING

FAILURE TO COMPLY WITH PROPER INSTALLATION AND MAINTENANCE INSTRUCTIONS COULD CONTRIBUTE TO THE VALVE FAILURE.

This Hot Water Master Tempering Valves cannot be used for tempering water temperature at fixtures. Severe bodily injury (i.e., scalding or chilling) and/or death may result depending upon system water pressure changes and/or supply water temperature changes. ASSE standard 1016, 1069 or 1070 listed devices should be used at fixtures to prevent possible injury.

These Hot Water Tempering Valves are designed to be installed at or near the boiler or water heater. They are not designed to compensate for system pressure fluctuations and should not be used where ASSE standard 1016, 1069 or 1070 devices are required. These Powers valves should never be used to provide "anti-scald" or "anti-chill" service.

The components of the system must be of materials with a construction capable of withstanding the high limit output temperatures of the water heating source.

⚠ WARNING

Need for Periodic Inspection: Periodic inspection by a licensed contractor is required. Corrosive water conditions, temperatures over 210°F, and or unauthorized adjustments or repair could render the valve ineffective for service intended. Regular checking and cleaning of the valve's internal components and check stops helps assure maximum life and proper product function. Frequency of cleaning and inspection depends upon local water conditions and water temperature.

Flow Capacity at 50-50 mixed ratio

Model	Min. Flow Rate*	Min. Flow to ASSE 1017	C _v	Pressure Drop Across Valve						
				5psi (34 kPa)	10psi (69 kPa)	20psi (138 kPa)	30psi (207 kPa)	45psi (310 kPa)	60psi (414 kPa)	70psi (517 kPa)
SH1432 & LFSH1432	0.5 gpm 1.89 lpm	1 gpm 4 lpm	8.54	19 gpm 72 lpm	27 gpm 102 lpm	38 gpm 144 lpm	47 gpm 178 lpm	57 gpm 216 lpm	66 gpm 250 lpm	71 gpm 269 lpm
SH1434 & LFSH1434	0.5 gpm 1.89 lpm	1 gpm 4 lpm	19.00	42 gpm 159 lpm	60 gpm 227 lpm	85 gpm 322 lpm	104 gpm 394 lpm	127 gpm 481 lpm	147 gpm 556 lpm	159 gpm 602 lpm
SH1435 & LFSH1435	0.5 gpm 1.89 lpm	5 gpm 19 lpm	30.00	67 gpm 254 lpm	95 gpm 360 lpm	134 gpm 507 lpm	164 gpm 621 lpm	201 gpm 761 lpm	232 gpm 878 lpm	251 gpm 950 lpm

* Minimum flow when HydroGuard is installed at or near hot water source with recirculated tempered water with continuously operating recirculating pump.

Operation ■

Typical Flow

Hot and cold water supplies enter HydroGuard at indicated ports, (see Figure 1) then flow past their respective seats. Next, hot and cold water flow is directed to the mixing chamber where the thermostatic motor is located.

Temperature Change

With a rise in discharge temperature due to pressure or temperature fluctuation on the inlet, the actuator expands, decreasing flow of hot water. The reverse occurs with a drop in discharge temperature.

Responses

Temperature adjustment screw moves the actuator to the desired discharge temperature.

- Cold water supply failure – causes actuator to expand drastically reducing the flow of hot water*.
- Hot water supply pressure failure – causes actuator to contract drastically reducing the flow of cold water*.

*When tested in accordance to conditions described in ASSE 1017.

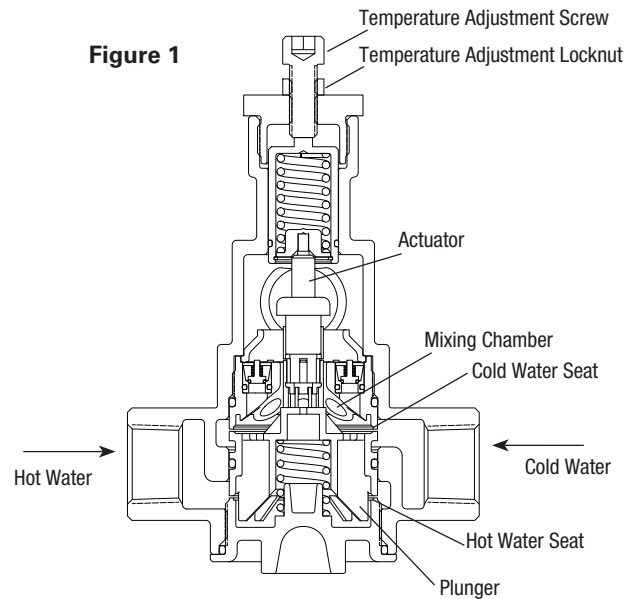

Installation Instructions ■

1. **IMPORTANT:** Installation should be in accordance with acceptable plumbing practices. Flush all piping thoroughly before installation. Installation and field adjustment are the responsibility of the installer.
2. Valves are to be installed as close to building inlet supply as possible to prevent/minimize pressure fluctuations.
3. Valve body can be rotated to install in multiple positions due to union inlets (see Figure 2). Make sure that union nuts are tightened securely.
4. Connect inlets and outlet and check for leaks.

5. **CAUTION:** When the HydroGuard supplies tempered water to self-closing and/or solenoid valves, provide a shock absorber (Powers Part No. 460-353) on the discharge line.

6. **Before use, check discharge temperature. Reset if necessary.**

OPERATION CHECK:

After HydroGuard is installed, make certain the supply stop valves and strainers are free of debris, clean and ready for operation by disassembling checkstops as shown in servicing.

Figure 2

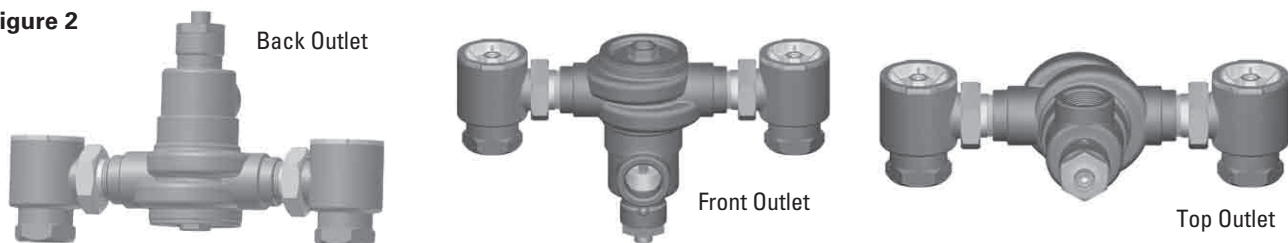

Maintenance and Troubleshooting ■

What to look for if:

- **The flow of water is less than desired...**
 - a. Stop valves or supply to HydroGuard not fully open.
 - b. Clogged checkstop strainer screens.
 - c. Accumulation of lime deposits around valve seats.
 - d. Low supply pressures.
- **The flow of water is completely shut off...**
 - a. Stop valves or supply valves are completely closed.
 - b. Valves downstream from HydroGuard fully closed.
 - c. Loss of either hot or cold water supply pressure.
- **Discharge temperature varies...**
 - a. Very large restriction in outlet flow.
 - b. Very large drop in inlet pressure.
 - c. Very large fluctuation of hot water supply temperature.
 - d. Worn valve seats.
 - e. Minimum flow requirement not achieved.
 - f. Lime deposits around motor, poppets and/or seat.

Parts List - SH1432, LFSH1432, SH1434, LFSH1434 ■

Index	Description	Part #			
		SH1432	LFSH1432	SH1434	LFSH1434
1	Checkstop Rebuild Kit	390 800	LF390 800	390 801	LF390 801
2	Plunger Kit	390 802	390 802	390 803	390 803
3	Adjusting Screw	390 688	390 688	390 688	390 688
4	O-Ring	390 805	390 805	390 806	390 806
5	Actuator - Standard Temperature	390 807	390 807	390 809	390 809
6	Actuator - Low Temperature	390 808	390 808	390 810	390 810
7	Funnel Kit	390 829	LF390 829	390 830	LF390 830
8	Locknut	1051117	1051117	1051117	1051117

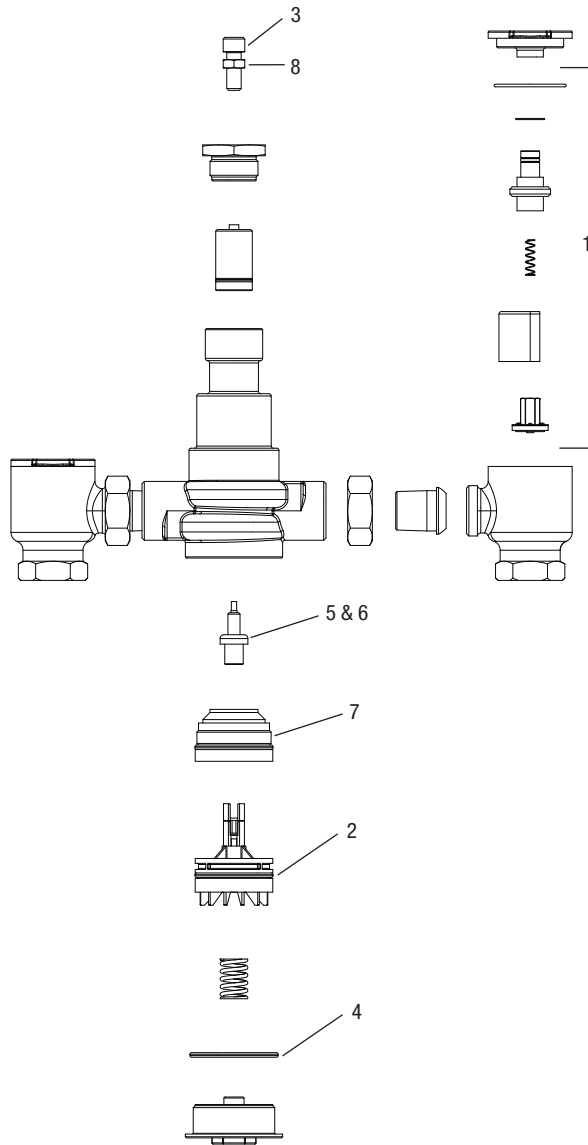

Parts List - SH1435, LFSH1435 ■

Index	Description	Part #	
		SH1435	LFSH1435
1	Checkstop Rebuild Kit	390 811	LF390 811
2	Plunger Kit	390 812	390 812
3	O-Ring	390 813	390 813
4	Actuator - Standard Temperature	390 814	390 814
5	Actuator - Low Temperature	390 815	390 815
6	Funnel Kit	390 831	LF390 831
7	Adjusting Screw	390 688	390 688
8	Locknut	105 1117	105 1117

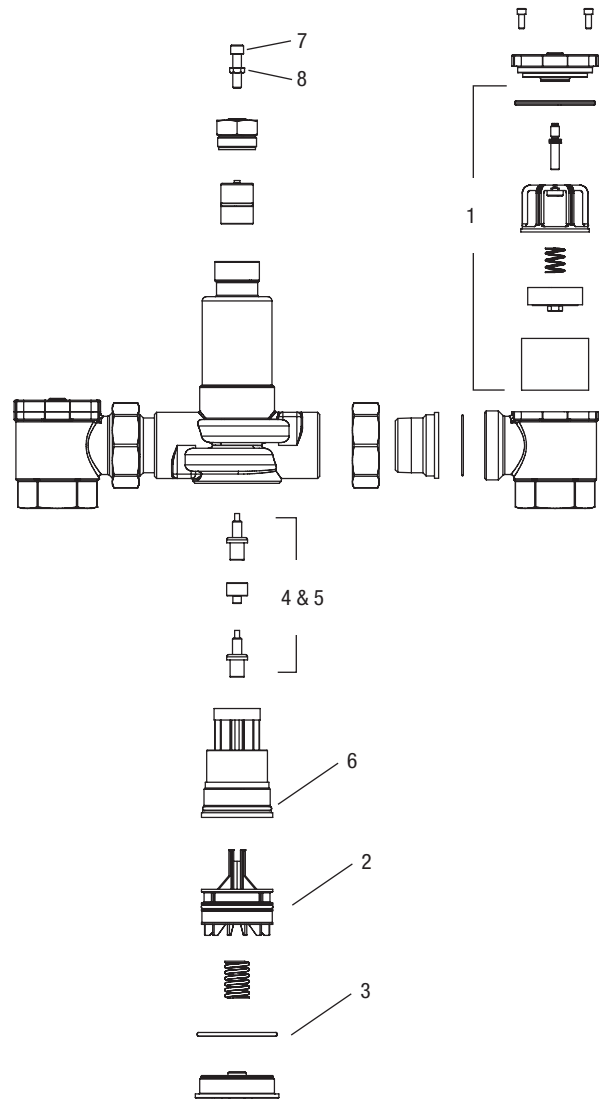

Servicing ■

NOTE: Before disassembling, make certain both hot and cold water supplies are shut off.

Checkstop Disassembly

1. Remove bonnet with socket wrench.
2. Lift out strainer screen.
3. Reassemble in reverse order.

Valve Disassembly

To Remove Thermal Actuator from Top

1. Loosen locknut.
2. Remove bonnet and pull out overload assembly by using standard pliers.
3. Lift out thermal actuator by using a needle nose plier.
4. Reassemble in reverse order.
- 5. Temperature setting must be checked by an installer before use. See temperature adjustment below.**

To Remove The Plunger Assembly Or Funnel from Bottom

1. Remove the bottom cap. **Caution:** spring is under tension.
 2. Pull out spring.
 3. Pull out plunger using a pair of pliers.
 4. To remove Funnel, you will need a deep socket wrench and funnel removal tool.
 5. Reassemble in reverse order.
 - 6. Temperature setting must be checked by an installer before use. See temperature adjustment below.**
- Note: After reassembling go back to thermal actuator section and make sure it is sitting in its holder properly.

Temperature Adjustment ■

Temperature setting for SH1430 or LFSH1430 Series Valves:

1. Turn off re-circulation pump (if one is in the system).
2. Open up enough fixtures to meet minimum flow requirement of:
 - SH1432 and LFSH1432 = 1 gpm (4 Lpm)
 - SH1434 and LFSH1434 = 1 gpm (4 Lpm)
 - SH1435 and LFSH1435 = 5 gpm (19 Lpm)
3. Loosen locknut (see Fig. 1)
4. Turn temperature adjusting screw counterclockwise to increase or clockwise to decrease the outlet temperature. (see Fig. 1)

NOTE: Please allow valve temperature to settle in before making your next adjustment.

5. When desired temperature is set, tighten the locknut. Turn re-circulation pump back on. Close open fixtures.

CALIFORNIA PROPOSITION 65 WARNING

WARNING: This product contains chemicals known to the State of California to cause cancer and birth defects or other reproductive harm. (California law requires this warning to be given to customers in the State of California.)

For more information: www.watts.com/prop65

ATTENTION INSTALLER: After installation, please leave this Instruction Sheet for occupant's information.

WARNING

NOTE: AFTER COMPLETING REPAIRS, CHECK DISCHARGE TEMPERATURE. (115°F [46°C]). RESET IF NECESSARY.

WARNING: FAILURE TO PERFORM THIS OPERATION COULD RESULT IN UNSAFE DISCHARGE TEMPERATURE, WHICH MAY CAUSE INJURY OR DEATH.

POWERS™

A Watts Water Technologies Company

**ISO 9001-2008
CERTIFIED**

USA: Phone: 1.800.669.5430 • Fax 1.847.229.0526 • www.powerscontrols.com
Canada: Phone: 1.888.208.8927 • Fax 1.888.479.2887 • www.powerscontrols.ca