

FLEXSTEEL®

W1042-860

Dresser

IMPORTANT

Carefully remove all parts from the carton, and put them individually on a soft cloth to prevent damage to the parts.

We have taken great care in the design of this product and request that you carefully and accurately follow our assembly instructions to ensure proper set-up.

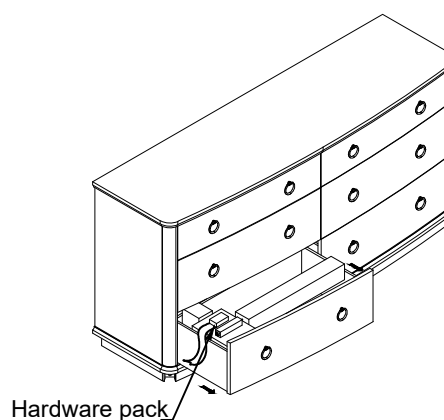
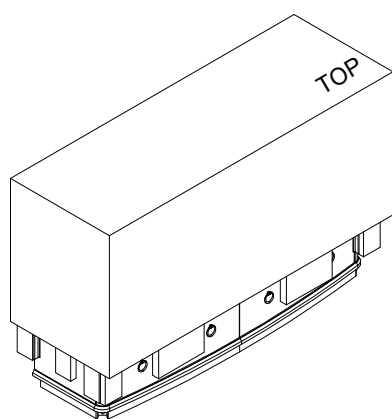
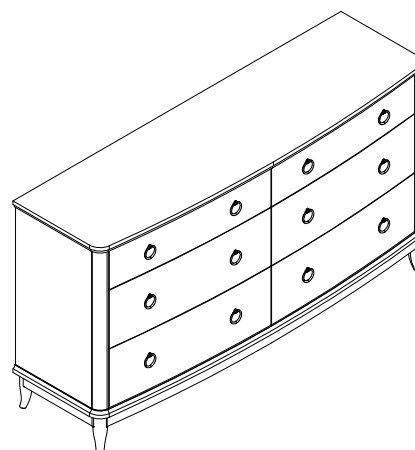

Part List

Assembly Instructions 1/3

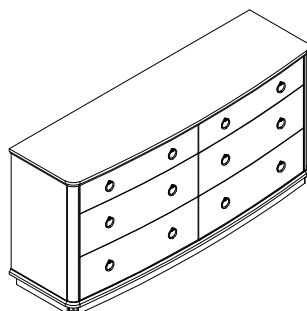

A. Dresser
1 piece



B. Leg
4 pieces



C. Support Leg
1 piece

Hardware List

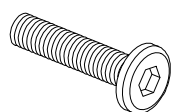

Bolt
Ø5/16" x 18 UNC x 1-3/4"
8 pieces



Spring Washer
Ø5/16" x 1.5mm
8 pieces



Flat Washer
Ø5/16" x Ø19 x 1.5mm
8 pieces

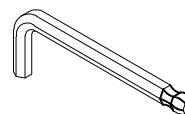

Hex Key
5/32"
1 piece

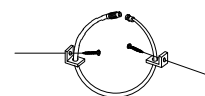

Anti-Tipping
1set

FLEXSTEEL®

Assembly Instructions 2/3

IMPORTANT NOTES

- Do not tighten up all the bolts until each part is properly assembled.
- Keep the Hex Key in a safe place as you may need to tighten up the bolts in the future.
- Use a soft cloth between these parts and the floor.
- We recommend this product be assembled by at least two adults.

STEP 1

Pull out the bottom drawer box to get out the assembly parts - legs (B) and support leg (C) . (See Figure 1)

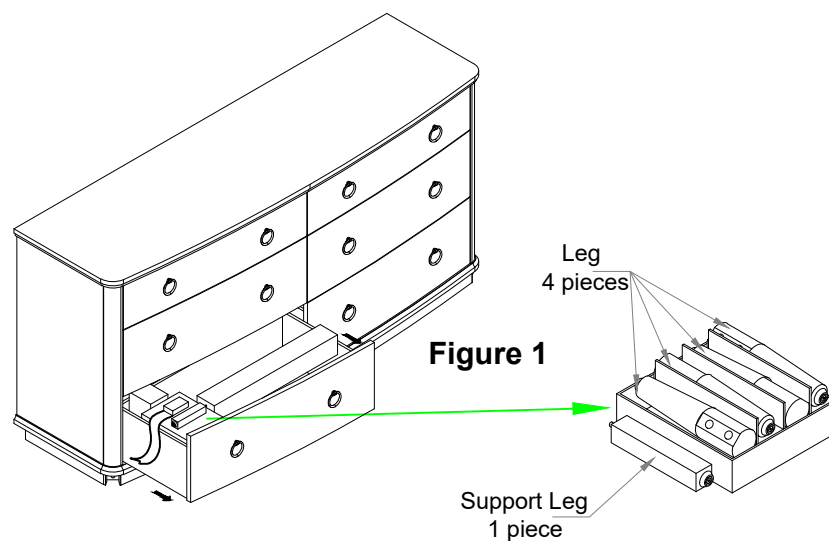

STEP 2

Fix Legs (B) to each corner of the Dresser (A). Insert Bolt, Spring Washer, Flat Washer and fully tighten bolts with Hex Key. (See Figure 2), Connect the Support Leg (C) to Dresser (A). (See Figure 3)

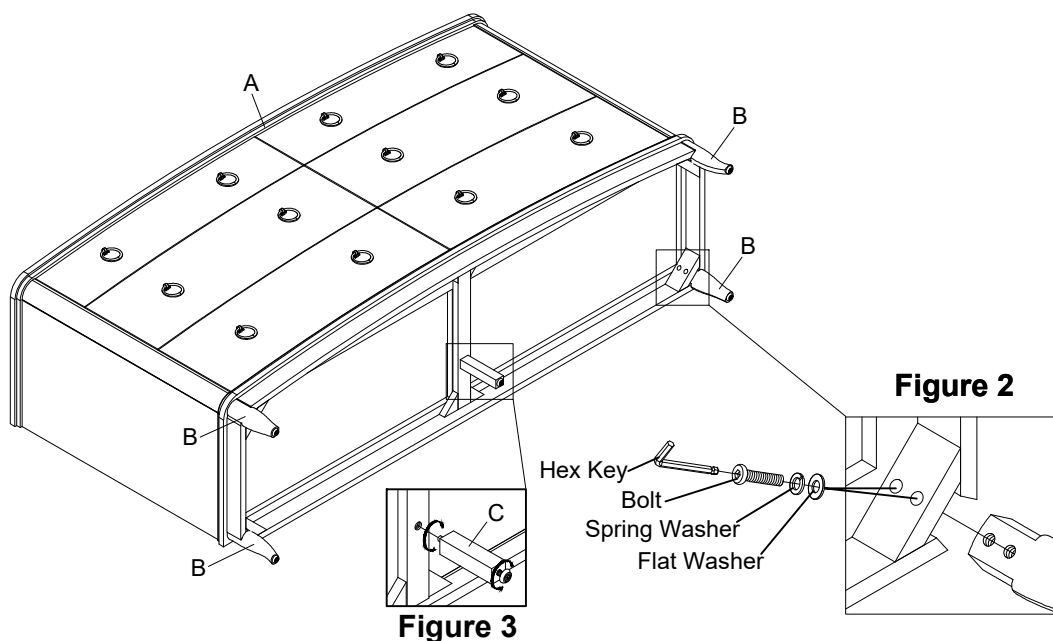

FLEXSTEEL®

Assembly Instructions 3/3

IMPORTANT NOTES

- Do not tighten up all the bolts until each part is properly assembled.
- Keep the Hex Key in a safe place as you may need to tighten up the bolts in the future.
- Use a soft cloth between these parts and the floor.
- We recommend this product be assembled by at least two adults.

STEP 3

Adjust the levelers on the legs until the furniture is leveled. (See Figure 4)

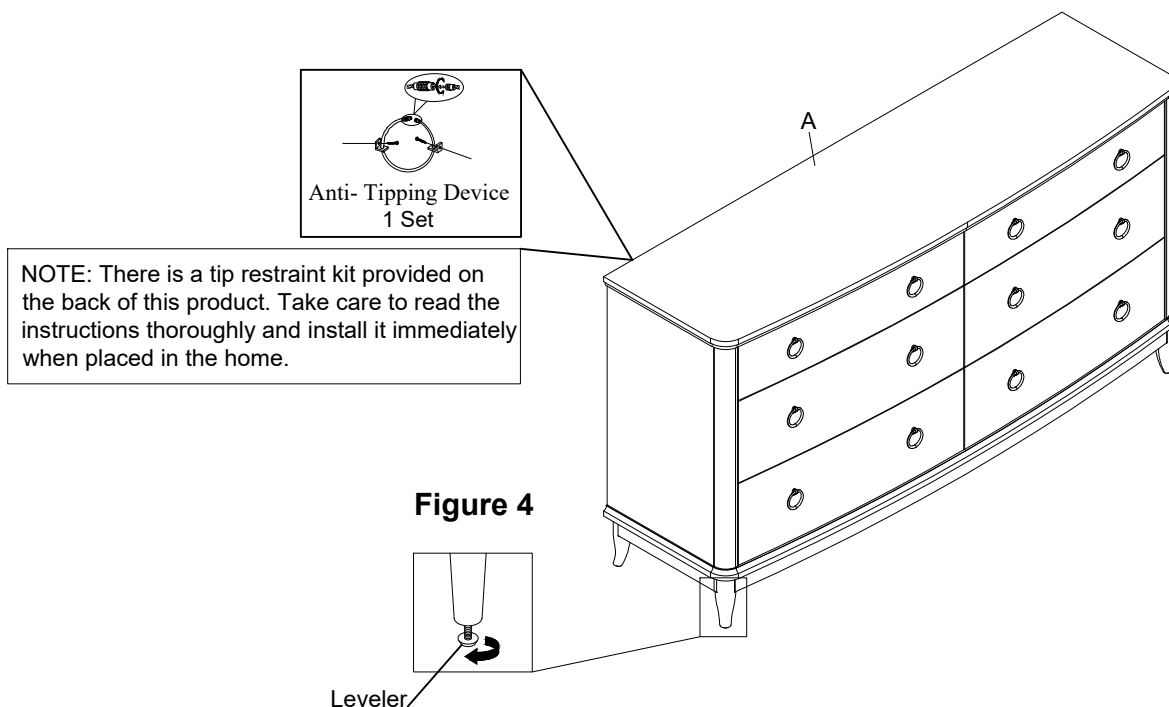

CARE INSTRUCTIONS

- To avoid scratches, do not place sharp or jagged objects directly on the cabinet.
- Do not place hot items directly on the cabinet.
- Use placemats or trivets under hot items and coasters under beverages to prevent marks and stains.
- Avoid the use of harsh chemicals or abrasive cleaning materials.
- Wipe the cabinet clean with a soft, dry cloth after each use.
- Wipe up spills quickly with a soft, dry cloth.

Flexsteel Industries, Inc.

For Parts or Customer Service call

toll-free:

1-888-415-3979

Monday-Friday

8:00 a.m. -5:00 p.m.

(Central Time)

Email:

customersolutions@flexsteel.com

www.flexsteel.com