

Figure 1 - Base

Base Hardware Parts List:

- 2 - Leg & Rail Assembly
- 2 - End Rail
- 10 - Screws
- 10 - Washers
- 1 - Allen Wrench

**CAUTION:** Use care when handling your Clock. We recommend two people for the following assembly procedure. Perform this procedure prior to installing pendulum.

1. Locate and unpack the Base Hardware Parts.
2. Assemble the End Rails to the Leg & Rail Assemblies using Screws and Washers as shown in Figure 1 at four locations.
3. Choose a location for the Clock and gently lay it on its back.
4. Locate the Threaded Inserts on the bottom of the Clock and align with the holes on the Base. Attach the Base with Screws and Washers as shown in Figure 2 at six locations.
5. Carefully set the Clock upright and ensure stability on the floor. Refer to your set-up instructions for proper leveling procedures and safety strap assembly.

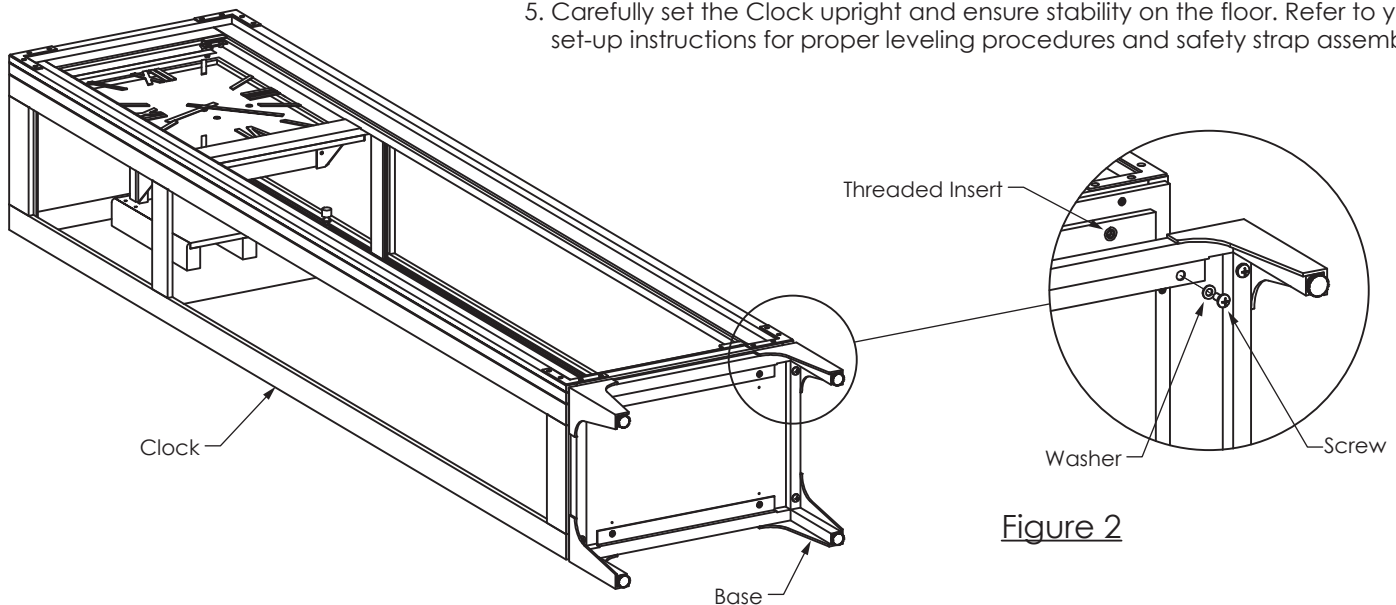

Figure 2