

SMART APP ONLINE UPS SYSTEM

BP36VL2U01TAA / BP48VL2U01TAA

INSTALLATION AND OPERATION MANUAL

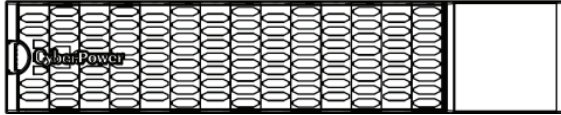

Front Panel

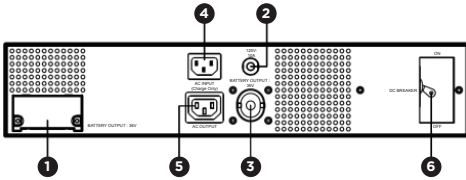

Back Panel: BP36VL2U01TAA

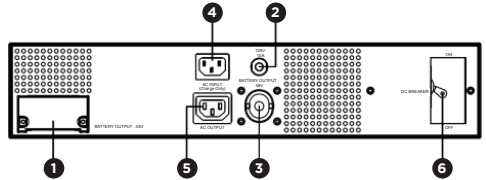

Back Panel: BP48VL2U01TAA

FEATURES

1. EBM DC Input Connector
2. AC Circuit Breaker
3. EBM DC Output Cable
4. AC Fast Charge Input (IEC320 C14)
5. AC Fast Charge outlet (IEC320 C13)
6. DC Breaker

Cyber Power Systems (USA), Inc.

TABLE OF CONTENTS



PRODUCT REGISTRATION	3
IMPORTANT SAFETY WARNINGS (SAVE THESE INSTRUCTIONS)	3
INTRODUCTION	4
Extended Battery Modules	4
Unpacking	4
Battery Module Features	5
INSTALLATION	5
Connection With UPS	5
Scenario #1: UPS with One Extended Battery Module (EBM)	5
Scenario #2: UPS with Multiple Extended Battery Modules (EBMs)	6
Extended Battery Modules Configuration	7
Rackmount Installation for 4-Post Rack	8
Rackmount Installation for 2-Post Rack	10
Vertical/Tower Installation	12
MAINTENANCE	13
Storage	13
Battery Replacement	13
Safety Precautions	13
Replacement Batteries	13
Battery Disposal	13
Battery Replacement	14
TECHNICAL SPECIFICATIONS	16
TROUBLESHOOTING	17
FCC COMPLIANCE STATEMENT	18
LIMITED WARRANTY AND CONNECTED EQUIPMENT GUARANTEE	18

PRODUCT REGISTRATION

CyberPower requests that you complete and return the Warranty Registration Card enclosed with the Product or register the Product at its website (www.cyberpowersystems.com/registration) to establish that you are the Initial Customer of the Product, and therefore entitled coverage under the Limited Warranty and the Connected Equipment Guarantee. (Registration is not required for coverage, but note: if you do not register your purchase, you will be required to provide proof of purchase.)

IMPORTANT SAFETY WARNINGS (SAVE THESE INSTRUCTIONS)

This manual contains important instructions that should be followed during installation and maintenance of the UPS Extended Battery Modules and batteries. The Smart App Online UPS Extended Battery Modules that are covered in this manual are intended for installation in an environment within 32°F to 104°F (0°C to 40°C), free of conductive contaminants.

	Warning: High Voltage - Risk of Electric Shock
	Do Not Discard Batteries in Trash

RISK OF ELECTRIC SHOCK

See Installation Instructions Before Connecting To The Supply. Do Not Disconnect Battery Connector Under Load. Batteries replaceable by SERVICE PERSONNEL (Non-Isolated Battery Supply): Risk of electric shock, battery circuit is not isolated from AC power source; hazardous voltage may exist between battery terminals and ground. Test before touching.

BATTERY PRECAUTIONS

CAUTION - Do not dispose of batteries in fire as the battery may explode.

CAUTION - Do not open or mutilate the battery, released electrolyte is harmful to the skin and eyes. It may be toxic.

CAUTION - RISK OF EXPLOSION IF BATTERY IS REPLACED BY AN INCORRECT TYPE. DISPOSE OF USED BATTERIES ACCORDING TO THE INSTRUCTIONS.

CAUTION - When replacing batteries, replace with the same number of the following battery: CyberPower RB1290X3D for BP36VL2U01TAA and RB1290X4N for BP48VL2U01TAA.

CAUTION - Risk of Energy Hazard, 36V (BP36VL2U01TAA) and 48V (BP48VL2U01TAA), maximum 18.8 Ampere-hour battery. Before replacing batteries, remove conductive jewelry such as chains, wrist watches, and rings. High energy through conductive materials could cause severe burns.

CAUTION - A battery can present a risk of electric shock and high short circuit current. The following precautions should be observed when working on batteries:

- Remove watches, rings, or other metal objects.
- Use tools with insulated handles.
- Wear rubber gloves and boots.
- Do not lay tools or metal parts on top of batteries.
- Disconnect charging source prior to connecting or disconnecting battery terminals.
- Remove battery grounds during installation and maintenance to reduce likelihood of shock. Remove the connection from ground if any part of the battery is determined to be grounded.

INTRODUCTION

Extended Battery Modules

Extended Battery Modules (EBMs) from CyberPower (BP36VL2U01TAA / BP48VL2U01TAA) increase battery runtimes during power outages. Each rack/tower convertible EBM uses 2U of rack space, depending upon the model, and can be installed in a tower form factor to match the UPS installation. The DC plug-and-play power connectors allow to daisy-chain additional EBMs to a UPS system. EBMs compatible with Smart App Online UPS systems also have a built-in battery charger, providing Fast Charge Technology to quickly restore the backup power supply. Every CyberPower EBM has a three-year warranty.

Unpacking

Inspect the unit upon receipt. The box should contain the following:

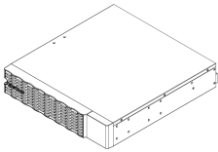

A



B



C

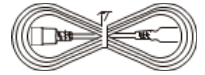

D



E



F

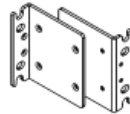

G



H



I



J



K



L



M



N



O

- A. Extended Battery Module
- B. 1 x Rackmount left rail
- C. 1 x Rackmount right rail
- D. 1 x IEC320 C14 to IEC320 C13 power cord
- E. 1 x IEC320 C14 to NEMA 5-15P power cord
- F. 1 x Tie plate
- G. 2 x Rackmount ears
- H. 2 x Rackmount handles
- I. 10 x Black M5X8L pan head screws
- J. 4 x Black M4X7L pan head screws
- K. 8 x Black M4X8L flat head screws
- L. 4 x Black M3X6L flat head screws
- M. 12 x rubber pads
- N. 10 x Cage nuts
- O. 18 x Screw hole dust covers
- P. Installation and Operation manual
- Q. Registration Warranty Card

INTRODUCTION

Battery Module Features

1. EBM DC Input Connector

Use this input connector to daisy-chain the next EBM. Remove the connector cover for access.

2. AC Circuit Breaker

Provides overload and fault protection.

3. EBM DC Output Cable

Use this output cable to connect the EBM to a UPS or to the next EBM.

4. AC Fast Charge Input (IEC320 C14)

Connect to a 208V, 30A, AC power source, or connect to the AC Fast Charge output from an upstream EBM.

5. AC Fast Charge outlet (IEC320 C13)

Use this outlet to connect to the Fast Charge AC input of a downstream EBM.

6. DC Breaker

Use the DC breaker to disconnect battery output.

INSTALLATION

Connection With UPS

Scenario #1: UPS with One Extended Battery Module (EBM)

Step 1: Turn off the DC breaker of the EBM.

Step 2: Loosen the two screws to remove the battery cable retention bracket of the UPS.

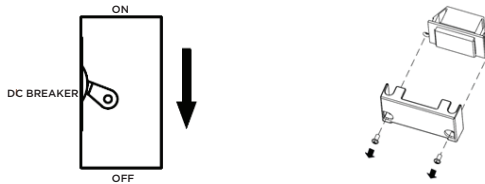

Step 3: Use the output cable of the EBM to connect the EBM to the UPS.

Step 4: Rotate the battery cable retention bracket and tighten the two screws to fix battery cable.

Step 5: Use a power cord to plug AC input inlet of the EBM into a wall receptacle.

Step 6: Turn on the DC breaker of the EBM.

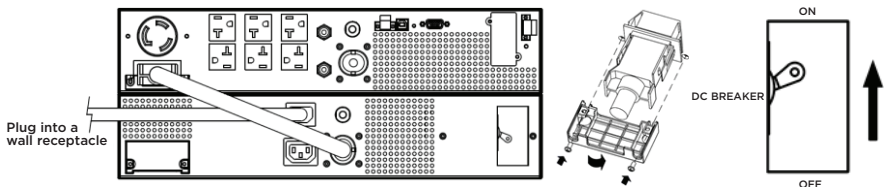

INSTALLATION

Scenario #2: UPS with Multiple Extended Battery Modules (EBMs)

- Step 1: Connect the first EBM to the UPS using the instructions above.
- Step 2: Turn off the DC breaker of the EBM.
- Step 3: Loosen the two screws to remove the battery cable retention bracket of the UPS.

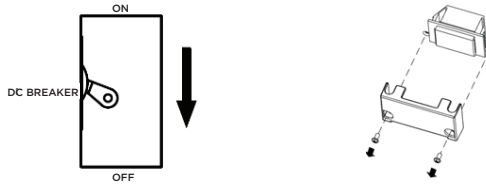

- Step 4: Use the output cable of the EBM to connect the EBM to the UPS.
- Step 5: Rotate the battery cable retention bracket and tighten the two screws to fix battery cable.
- Step 6: Use a power cord to plug AC input inlet of the EBM into a wall receptacle.
- Step 7: Turn on the DC breaker of the second EBM.
- Step 8: Set the EBM number to the respective setting to match the number of installed units. To do this via the LCD control panel, go to the Configuration Menu, then scroll to the EBM Number setting, select the appropriate number and save the configuration.

This operation can also be done via the RMCARD web UI or via PowerPanel Business Agent software. Please see their respective User Manual for instructions.

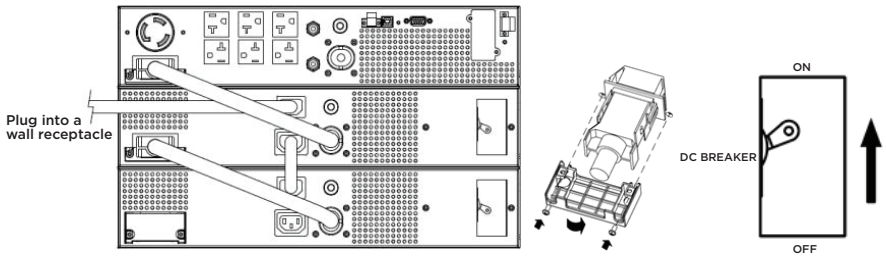

INSTALLATION

Extended Battery Modules Configuration

Extended Battery Modules can be configured by the user to display correct estimated battery runtimes.

- Step 1: Select **Main Menu** and press the **ENTER** button to activate the **Main Menu**.
- Step 2: Press the **UP** and **DOWN** buttons to select the **SET UP** icon.
- Step 3: Press the **ENTER** button to enter the **External Batt** option.
- Step 4: Press the **UP** and **DOWN** buttons to scroll to the **External Batt** option.
- Step 5: Press the **ENTER** button to enter the **External Batt** option.
- Step 6: Press the **UP** and **DOWN** buttons to select the number of EBM installed then press the **ENTER** button to set.
- Step 7: You may be prompted **Save Change?** to save the selection. If so, press the **ENTER** button to save the setting.
- Step 8: Press the **ESC** button to cancel or return to the previous **SET UP** menu.

Set Up Items	Available Settings	Default Settings
External Batt	= [0] [1] [2] [3] [4] [5] [6] [7] [8] [9] [10] Sets the actual EBM (extended battery modules) number to get the correct estimated runtime.	0

INSTALLATION

CyberPower Extended Battery Module (EBM) can be installed in a rackmount or vertical/tower orientation. This versatility is especially important to growing organizations with changing needs that value having the option to position an EBM on the floor or in a rackmount system. Note that the included rack mounting hardware is only compatible with square hole racks. Please follow the instructions below for the respective mounting methods.

Rackmount Installation for 4-Post Rack

	Caution: To prevent the risk of fire or electric shock, only use the supplied hardware to attach the mounting brackets.
--	--

Step 1: Screw the handles and install rackmount ear

Screw the handles on the rackmount ears using four black M3X6L flat head screws as shown below. Attach two rackmount ears to the EBM using eight black M4X8L flat head screws.

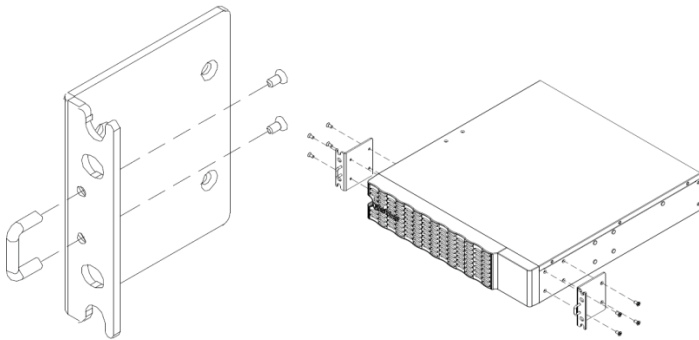

Step 2: Rackmount rail installation

Select the proper holes in the rack for positioning the EBM in the rack. The EBM takes up two rack units: rack hole positions 1 through 6.

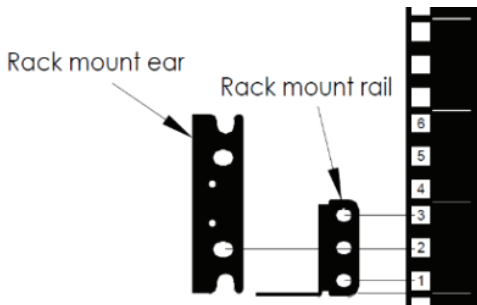

INSTALLATION

Step 3: Select the proper holes to insert the cage nuts

Select the proper holes in the rack for positioning the unit in the rack. Insert the cage nuts (Not needed for threaded rack)

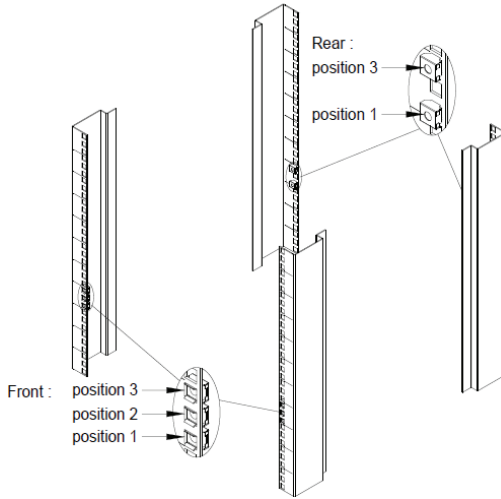

Step 4: Adjust rackmount rails to fit your rack

The mounting depth of the included rackmount rails can adjust from 18.1 inches to 29 inches (46 cm to 73.5 cm). Adjust the rail depth to match your rack depth. Attach each rackmount rail to your rack with two black M5X8L pan head screws at the front of the rack (square holes 1 and 3 as shown below). Secure each rail to the rear of the rack with two black M5X8L pan head screws.

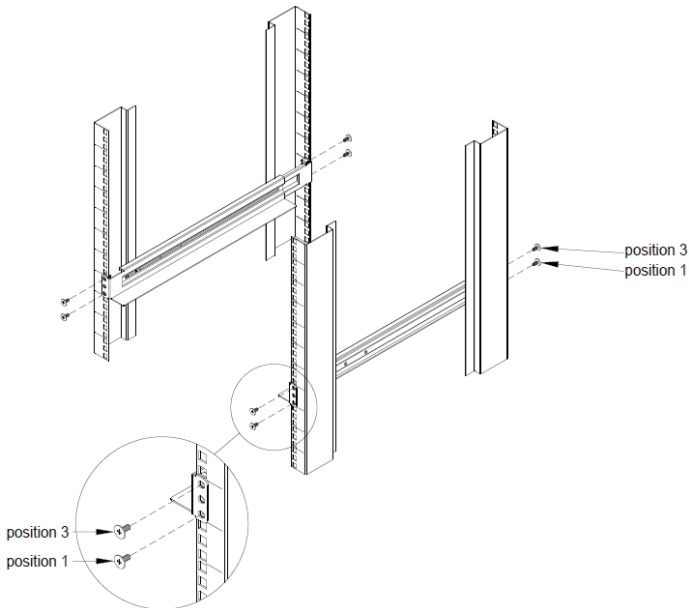

INSTALLATION

Step 5: Place and secure the EBM on the rails

Slide the hanging brackets on the EBM on to the rails mounted in the rack with the front of the unit facing toward you. Secure the EBM to your rack with two black M5X8L pan head screws at the front of the rack (square holes 2 and 5 as shown above).

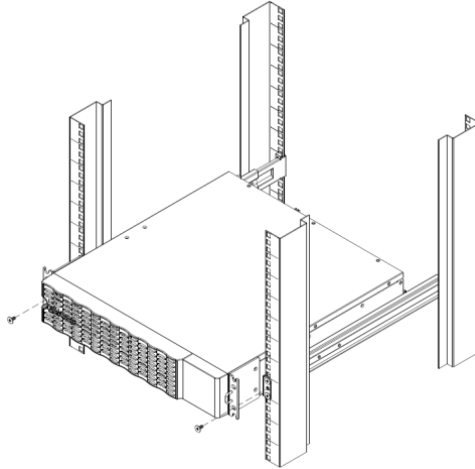

Rackmount Installation for 2-Post Rack

	CAUTION! Due to the weight of this unit, it is strongly recommended to install it at the bottom of the rack.
	CAUTION! Prior to installing the unit, remove internal batteries to reduce the weight of the unit. Refer to the battery replacement section in this user manual for instructions.
	CAUTION! It is strongly recommend having two to three people assist during the installation process.
	CAUTION! It is strongly recommended that the 2-post rack be bolted to the floor prior to the installation of the UPS.

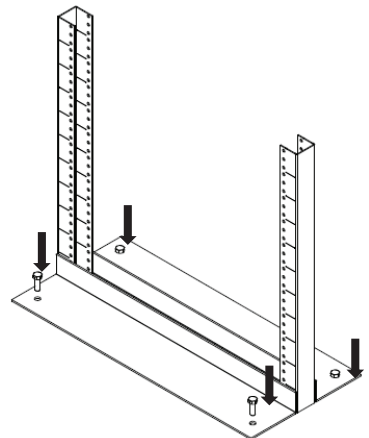

INSTALLATION

Step 1: Remove side dust covers and install rackmount ears

Remove eight dust covers from screw holes as shown below. Attach the included rackmount ears to the center holes on the sides of the EBM using eight black M4X8L flat head screws as shown below.

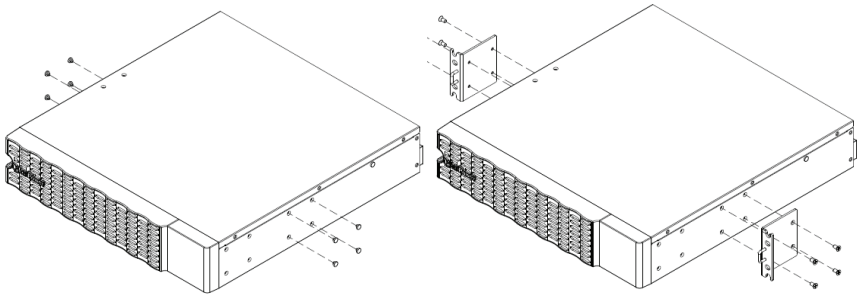

Step 2: Secure the EBM to the rack

Secure the EBM to your rack with four black M5X8L screws at the front of the rack (square holes 2 and 5 as shown below).

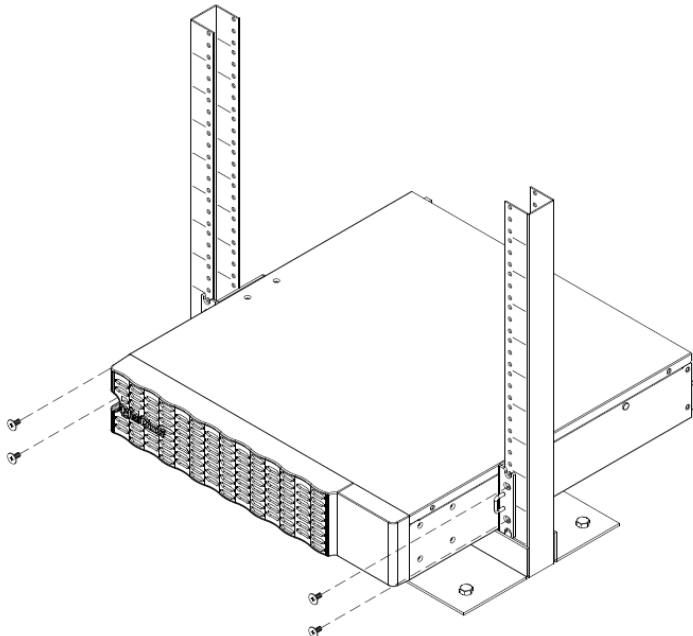

INSTALLATION

Vertical/Tower Installation

Step 1: Adhere rubber pads

Adhere the circular rubber pads to the stands and to the left-hand side of the UPS and EBM as shown below. This will become the bottom of the EBM. Insert the dust covers into the open screw holes on bottom.

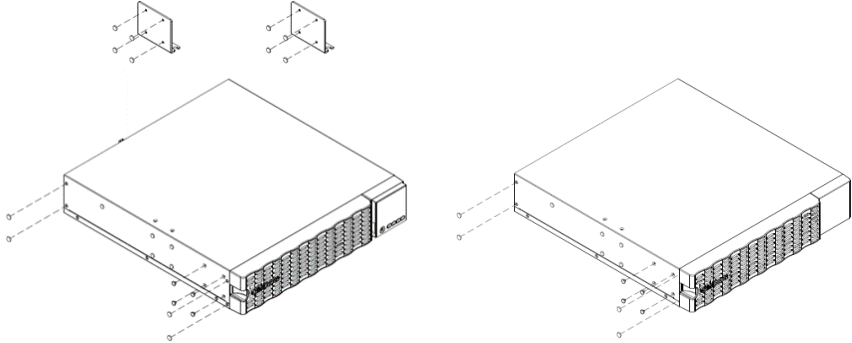

Step 2: Attach the base stands and attach the dust covers

Stand the EBM on its side with the rubber pads facing down. If installing the EBM together with a UPS, remove the four dust covers first and secure the tie plate between the UPS and the EBM using four black M4X7L pan head screws. Adhere four circular rubber pads to each tower stand and screw on to the EBM and UPS using four black M4X7L pan head screws for added stability as shown below. Insert the dust covers into the open screw holes on top.

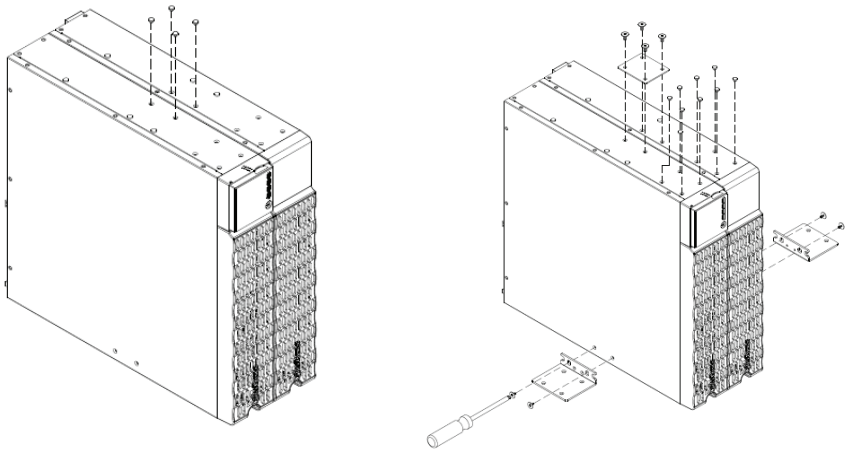

MAINTENANCE

Storage

To store your UPS for an extended period of time, cover and store it with the battery fully charged. Recharge the battery every three months to ensure battery life.

Battery Replacement

Please read and follow the Safety Instructions before servicing the battery. Battery replacement should be performed by trained personnel who are familiar with the procedures and safety precautions. Make a note of the Replacement Battery part number. When replacing batteries, replace with the same type and number of batteries or battery packs.

Safety Precautions

	Warning: High Voltage - Risk of Electric Shock
--	---

Only use replacement batteries that are certified by Cyber Power Systems. Use of incorrect battery type is an electrical hazard that could lead to explosion, fire, electric shock, or short circuit. Batteries contain an electrical charge that can cause severe burns. Before servicing batteries, please remove any conductive materials such as jewelry, chains, wrist watches, and rings. Do not open or mutilate the batteries. Electrolyte fluid is harmful to the skin/eyes and may be toxic.

To avoid electric shock, turn off and unplug the UPS from the wall receptacle before servicing the battery. Only use tools with insulated handles. Do not lay tools or metal parts on top of the UPS or battery terminals.

Replacement Batteries

Please refer to the front side of the EBM for the model number of the correct replacement batteries. For battery procurement, go to www.CyberPowerSystems.com, or contact your local dealer. When the Replace Battery the LCD displays Service Battery, use PowerPanel Business software or log on to the RMCARD to perform a runtime calibration to verify battery capacity is sufficient and acceptable.

Battery Disposal

	Do Not Discard Batteries in Trash
--	--

Batteries are considered hazardous waste and must be disposed of properly. Contact your local government for more information about proper disposal and recycling of batteries. Do not dispose of batteries in fire. Cyber Power Systems encourages environmentally sound methods for disposal and recycling of its UPS products. Please dispose and/or recycle your UPS and batteries in accordance with local regulations.

MAINTENANCE

Battery Replacement

Step 1: Remove the front panel and unscrew the battery access door.

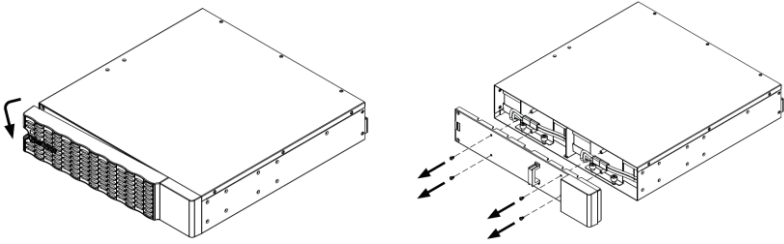

Step 2: Disconnect the internal battery connectors and unscrew the thumbscrew on the battery retention bracket and then remove it. This screw is designed to be fixed on the door, do not remove it from the metal cover.

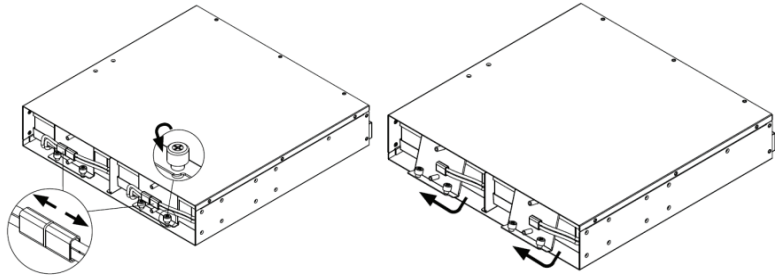

Step 3: Pull the battery trays out slowly and then put the new battery trays into the compartment.

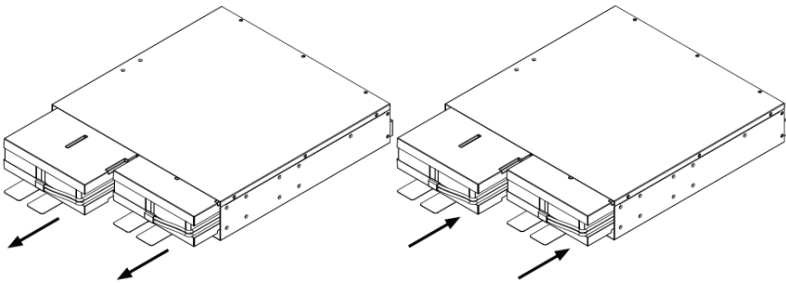

MAINTENANCE

Step 4: Assemble the battery retention bracket and tighten the thumbscrew. Connect the internal battery connector. Ensure that they are seated properly (connector will click into place).

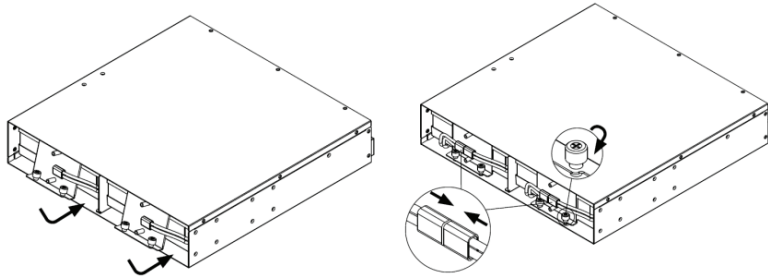

Step 5: Screw the battery access door and install the front panel.

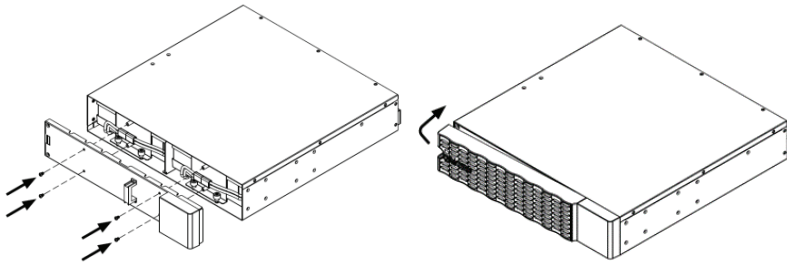

Step 6: Execute a battery test via the LCD control panel. To do this go to the Main Menu and select the Diagnostics Icon, then select Battery Test and Activate. After Battery test, go back to the Main Menu then select the Set Up icon, then select Batt Install Date to set the battery installation date. This operation can also be done via PowerPanel Business or the RMCARD web interface. Please see their respective User Manuals for detailed instructions.

TECHNICAL SPECIFICATIONS

MODEL	BP36VL2U01TAA	BP48VL2U01TAA
Configuration		
AC Input Voltage	100 - 125 VAC	
DC Output Voltage	36 VDC	48 VDC
DC Output Current	63 A	71 A
Physical		
Dimensions Length/Width/Height	14.96 x 17.05 x 3.4 in 38 x 43.3 x 8.65 cm	18.5 x 17.05 x 3.4 in 47 x 43.3 x 8.65 cm
Net Weight	51.15 lbs. / 23.2 Kg	65.26 lbs. / 29.6 Kg
Battery		
Specifications	6 x 12 V / 9 Ah	8 x 12 V / 9 Ah
Replacement Battery Cartridge	2 x RB1290X3D	2 x RB1290X4N
Recharge time 0-90% (typical)	4 hours	
Hot-Swappable	Yes	
Built-in Charger	Yes	
Environment		
Operating Temperature	32 °F to 104 °F / 0 °C to 40 °C	
Operating Relative Humidity	0 to 90% Non-Condensing	
Safety		
Conformance Approvals	UL1778 CSA C22.2 NO.107.3 FCC part 15 Class B	UL1778 CSA C22.2 NO.107.3 FCC part 15 Class A
Environmental	RoHS Compliant	

TROUBLESHOOTING

Problem	Possible Cause	Solution
WARNING		
BAT Disconnected	No battery power is being detected by the UPS.	Check the battery connector and the battery breaker.
Battery Failure	UPS has failed a Battery Test.	Check the battery connector and the battery breaker. Contact technical support to replace battery if under the warranty period.
Service Battery	The battery replacement date has reached the recommended maintenance period.	Perform a runtime calibration to verify battery capacity is sufficient and acceptable. If batteries have been recently replaced, then reset the Battery Replacement Date using PowerPanel Business Agent software, RMCARD web interface or through the LCD control panel on the UPS (See LCD Configuration Settings).
FAULT		
Over Charge	Battery is overcharged.	Remove the battery connector and check charger voltage.
Charger Failure	Charger has failed.	Contact CyberPower Systems at: cyberpowersystems.com for repair.

Additional troubleshooting information can be found at www.cyberpowersystems.com.

FCC COMPLIANCE STATEMENT

This device complies with part 15 of the FCC rules. Operation is subject to the following two conditions: (1) this device may not cause harmful interference, and (2) this device must accept any interference received, including interference that may cause undesired operation.



Warning: Changes or modifications not expressly approved by the party responsible for compliance could void the user's authority to operate the equipment. This document is believed to be accurate, but CyberPower reserves the right to change or correct the contents and does not assume any responsibility for omissions or errors.

For BP48VL2U01TAA with 2200VA, 3000VA Online UPS Models:

NOTE: This equipment has been tested and found to comply with the limits for a Class A digital device, pursuant to part 15 of the FCC Rules. These limits are designed to provide reasonable protection against harmful interference when the equipment is operated in a commercial environment. This equipment generates, uses, and can radiate radio frequency energy and, if not installed and used in accordance with the instruction manual, may cause harmful interference to radio communications. Operation of this equipment in a residential area is likely to cause harmful interference in which case the user will be required to correct the interference at his own expense.

The Class A digital apparatus meets all requirements of the Canadian Interference-Causing Equipment Regulation.

Cet appareil numérique de la class A respecte toutes les exigences du Règlement sur le matériel brouilleur du Canada.
CAN ICES-3(A)/NMB(A)

Shielded signal cables must be used with this product to ensure compliance with the Class A FCC limits.

For BP36VL2U01TAA with 1000VA, 1500VA Online UPS Models:

NOTE: This equipment has been tested and found to comply with the limits for a Class B digital device, pursuant to part 15 of the FCC Rules. These limits are designed to provide reasonable protection against harmful interference in a residential installation. This equipment generates, uses, and can radiate radio frequency energy and, if not installed and used in accordance with the instructions, may cause harmful interference to radio communications. However, there is no guarantee that interference will not occur in a particular installation. If this equipment does cause harmful interference to radio or television reception, which can be determined by turning the equipment off and on, the user is encouraged to try to correct the interference by one or more of the following measures:

- Reorient or relocate the receiving antenna.
- Increase the separation between the equipment and receiver.
- Connect the equipment into an outlet on a circuit different from that to which the receiver is connected.
- Consult the dealer or an experienced radio/TV technician for help.

The Class B digital apparatus meets all requirements of the Canadian Interference-Causing Equipment Regulation.

Cet appareil numérique de la class B respecte toutes les exigences du Règlement sur le matériel brouilleur du Canada.
CAN ICES-3(B)/NMB(B)

LIMITED WARRANTY AND CONNECTED EQUIPMENT GUARANTEE

Please visit www.CyberPowerSystems.com for a copy of the Limited Warranty and Connected Equipment Guarantee.

Where Can I Get More Information?

The application of the United Nations Convention of Contracts for the International Sale of Goods is expressly excluded. CyberPower is the warrantor under this Limited Warranty. For further information please feel free to contact CyberPower at: Cyber Power Systems (USA), Inc. 4241 12th Ave E., STE 400, Shakopee, MN 55379; call us at (877) 297-6937; or submit a web ticket online at cyberpowersystems.com/support.

Disposal

Cyber Power Systems (USA), Inc. encourages environmentally sound methods for disposal and recycling of its UPS products. Please dispose and/or recycle your UPS and batteries in accordance to the local regulations of your state.

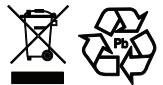

The Waste Electrical and Electronic Equipment (WEEE) Directive aims to contribute to sustainable production and consumption by contributing to the efficient use of resources and the retrieval of secondary raw materials through re-use, recycling, and other forms of recovery. The symbol on this product and/or its packaging indicates that the product must be disposed of separately from ordinary household wastes at its end of life. Contact your related WEEE management authority, local office, or your household waste disposal service about information on the recycling drop off site.

This product contains non-spillable lead acid batteries. The used batteries are considered hazardous waste and must be disposed through recycling. Do not dispose of used batteries with your ordinary household wastes. Dispose of the batteries according to local regulations. Note: Most retailers that sell lead-acid batteries collect used batteries for recycling, as required by local regulations.

WARNING: This product can expose you to chemicals including bisphenol A (BPA) and styrene, which is known to the State of California to cause reproductive harm and cancer. For more information, go to www.P65Warnings.ca.gov.