

Safety 1st®



See our full line of crash tested accessories at
www.safety1st.com

Safety 1st®

Alpha Elite 65

rear-facing child restraint

5-40 lbs (2.3-18 kg) and 19-40 in. (48-101.6 cm)

forward -facing child restraint

22-65 lbs (10.1-29 kg) and 29-49 in. (73.6-125 cm)

and at least 1 year old

belt-positioning booster

40-100 lbs (18.1-45.4 kg) and 43-52 in. (110.1-132.1 cm)

**KEEP INSTRUCTIONS
FOR FUTURE USE.**

Read all instructions before
using this child restraint.



⚠ WARNING:

**Failure to follow the warnings on the labels and
in the instruction manual can result in serious
injury or death to your child.**

4358-7077A 1.6.17



© 2016 Dorel Juvenile.

A. Before You Begin.....Pages 3-8

- A-1 Thank You...
- A-2 Registration and Safety Notices
- A-3 Understanding Your Child Restraint

B. Safety Information..... Pages 9-10

- B-1 Vehicle Seating Position
- B-2 Installation in Vehicle
- B-3 Child Restraint Use

C. Basic UsePages 11-27

- C-1 Choose Position for Your Child
- C-2 Preparing Child Restraint to Fit Your Child
- C-3 Securing Child in Child Restraint
- C-4 Removing Child From Child Restraint
- C-5 Accessories on Select Models
- C-6 Reclining Child Restraint
- C-7 Removing Harness System
- C-8 Installing Harness System
- C-9 Removing Seat Pad for Cleaning

D. General Vehicle InstallationPages 28-37

- D-1 Vehicle Seating Position
- D-2 Choosing Lower Anchor or Vehicle Belts
- D-3 Knowing Your Vehicle Belts
- D-4 Using Locking Clip
- D-5 Installing on Aircraft

E. Installing Rear-Facing..... Pages 38-46

E-1 Preparing to Install Rear-Facing

E-2 Preparing to Install Lower Anchor Belt Rear-Facing

E-3 Install Rear-Facing with Lower Anchor Belt



E-4 Install Rear-Facing with Vehicle Belts



F. Installing Forward-Facing Pages 47-54

F-1 Preparing to Install Forward-Facing

F-2 Adjusting Top Anchorage Strap (Tether)

F-3 Preparing to Install Lower Anchor Belt Forward-Facing

F-4 Install Forward-Facing With Lower Anchor Belt



F-5 Install Forward-Facing with Vehicle Belts



G. Installing Belt-Positioning Booster Pages 55-58

G-1 Preparing to Install Belt-Positioning Booster

G-2 Installing Using the Lap and Shoulder Belts



General Information.....Pages 59-62

- Troubleshooting
- Replacement Parts Order Form
- Warranty

A-1 Thank You...

Thank you for choosing this car seat, referred to throughout this manual as a child restraint. The DJG family is committed to creating a child restraint with the most comfort and convenience available today.

Remember, parents are a child's first teachers and examples. If you always buckle your seat belt, your child will think it is the natural thing to do. Make it a firm rule that the vehicle does not go until everyone is buckled up. Make no exceptions.

No one can predict if use of a child restraint will prevent injury or death in a particular crash. However, combined with careful driving, proper use of a child restraint can lower a child's risk of injury or death in most crashes.

Your child's safety is worth the time it will take to read and follow these instructions. After reading, if you still have questions or have any problems with this child restraint, please contact our Consumer Care Department at:

Dorel Juvenile Group, Inc.

Website: www.djgusa.com
Mailing Address: Dorel Juvenile Group, Inc.
Attn: Consumer Care
P.O. Box 2609
Columbus, IN 47202-2609
Telephone: 1-800-544-1108
8 A.M. to 6 P.M. EST M-TH
8 A.M. to 4:30 P.M. EST FRI

A-2 Registration and Safety Notices

Please complete the postage-paid registration card that came with your child restraint, and send it to us. Child restraints could be recalled for safety reasons. You must register this restraint to be reached in a recall. Send your name, address, email address if available and the restraint's model number and manufacturing date to:

Dorel Juvenile Group, Inc.
PO Box 2609, Columbus, IN 47202-2609
Attn: Consumer Care

or call 1-800-544-1108 or register online at www.djgusa.com/registration/carseat/us.

For recall information, call the U.S. Government's Vehicle Safety Hotline at 1-888-327-4236 (TTY: 1-800-424-9153), or go to <http://www.NHTSA.gov>

A. Before You Begin

Consumer: Just fill in your name, address and email. Please print (use dark ink).

Your Name _____

Your Street Address _____

State _____ ZIP _____

Address (optional) _____

BC027-ASW SF 1 BOOST AIR PROTECT 08/05/2010

P522 B 061950

If you don't have the card or if your address changes, you will find the model number and manufactured date on the label located on side of plastic shell.



A-3 Understanding Your Child Restraint

Front View

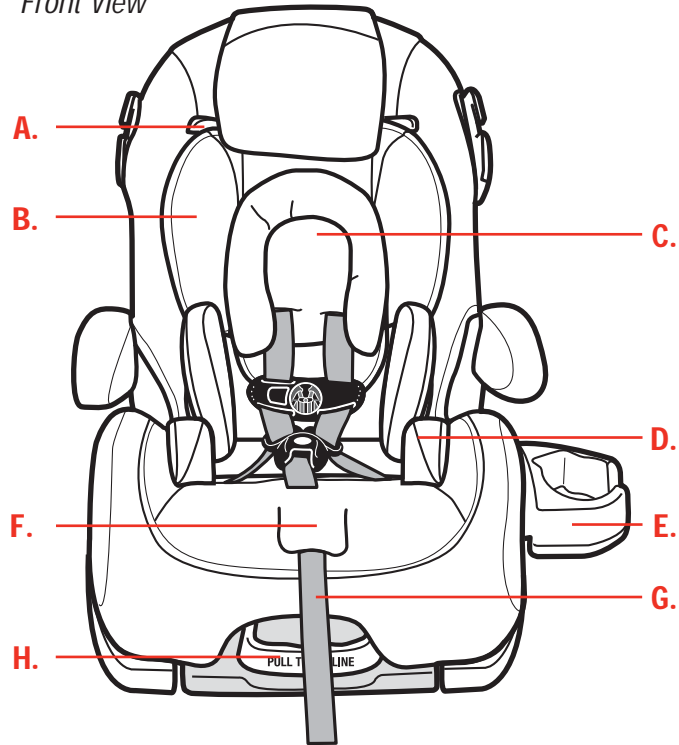

- A. Headrest/Harness Height Adjustment Levers**
- B. Adjustable Headrest**
- C. Infant Insert**
(on select models)
- D. Lumbar Support**
(on select models)
- E. Cup Holder**
(on select models)
- F. Harness Release Lever** (under flap)
- G. Harness Tightening Strap**
- H. Recline Lever**

Harness System Detail

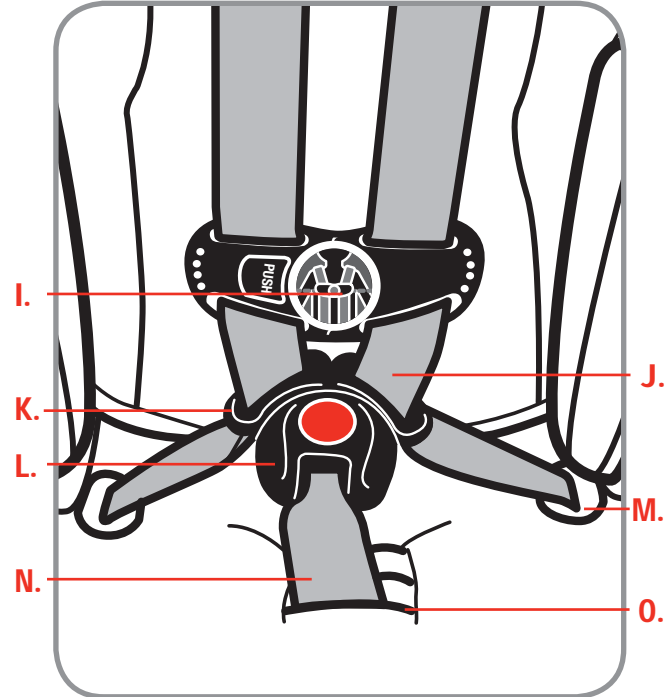

- I. Chest Clip**
- J. Harness Straps**
- K. Buckle Tongue**
- L. Buckle**
- M. Harness Guides**
- N. Buckle Strap**
- O. Buckle Strap Slots**

A. Before You Begin

Back View

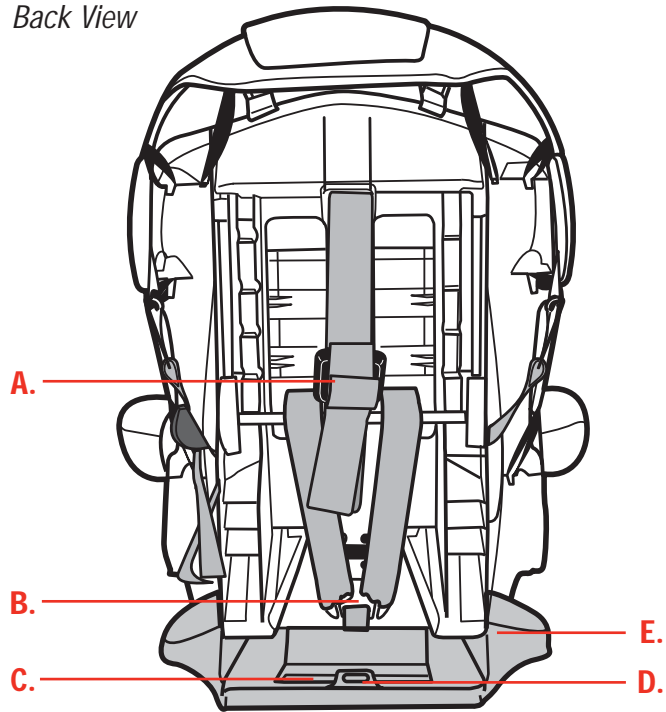

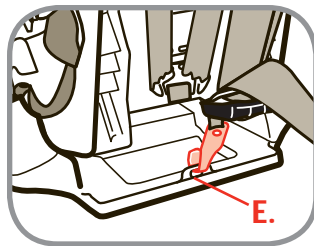

- A.** Top Anchorage (Tether) Strap 
- B.** Splitter Plate
- C.** Instructions (in bottom of base)
- D.** Top Anchorage (Tether) Hook Storage
- E.** Non Removable Base

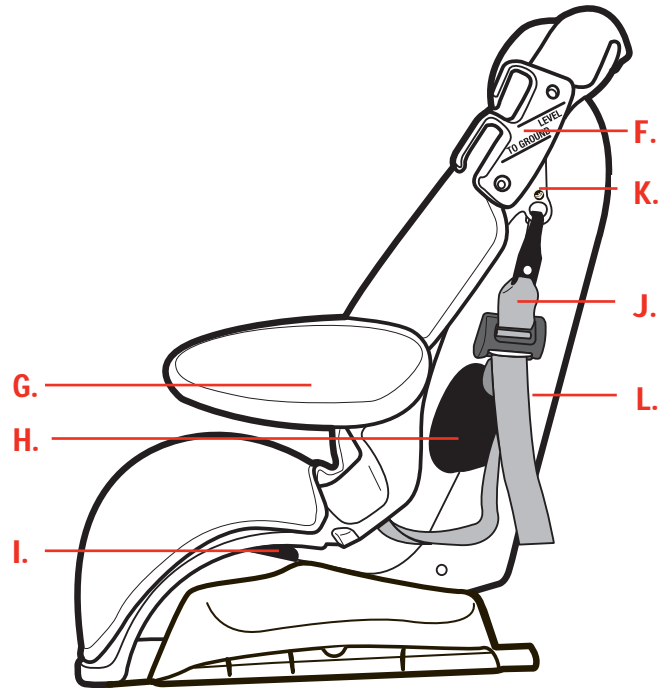

Side View



- F.** Shoulder Belt Positioning Guide & Rear Facing Level To Ground Line
- G.** Rotating Armrests
- H.** Forward-Facing Belt Path
- I.** Rear-Facing Belt Path
- J.** Lower Anchor Belt 
- K.** Lower Anchor Belt Storage 
- L.** Rear-Facing Level to Ground Lines

A. Before You Begin

B-1 Vehicle Seating Position



- ▲ Never place a child rear-facing in a seating position with an active frontal airbag.
- ▲ Check the vehicle owner's manual for more information about air bag/child restraint use.
- ▲ For vehicles without a back seat, refer to your vehicle owner's manual.

B-2 Installation in Vehicle

- ▲ Check the vehicle belt or lower anchor belt before each use. Use only if the belt is tightened properly and securely.
- ▲ This child restraint should be securely belted in the vehicle even when not in use. In a crash or sudden stop, an unsecured child restraint could injure occupants.
- ▲ Do not use a child restraint that has been in a crash. You must get a new child restraint.

B-3 Child Restraint Use

- ▲ Never take your child out of the child restraint while the vehicle is moving. Never leave child unattended.
- ▲ Placing your child in a hot child restraint may result in burns.
- ▲ Do not use a child restraint with damaged or missing parts.
- ▲ Do not use cut, frayed or damaged harnesses.
- ▲ Do not lubricate buckles and fasteners.
- ▲ Do not substitute parts or try to modify the child restraint in any way.
- ▲ Do not use any car seat accessory except those approved by Dorel Juvenile Group.
- ▲ Never allow any child to play with this child restraint; it is not a toy.
- ▲ Do not remove or cover up any of the warning labels or other labels on the child restraint.
- ▲ Read all instructions for additional warnings.
- ▲ On the side of the child restraint there is a date of manufacture label. Do not use this child restraint more than 10 years after the date of manufacture.

C-1 Choose Position for Your Child

Your child's height, weight, and age determine how your child restraint should be placed in the vehicle.

Please talk to your doctor about the best option for your child.

⚠️ WARNING: Verify your child's weight and height (do not guess) before choosing the child restraint's placement.



5-40 lbs (2.3-18 kg)
and 19-40 in. (48-101.6 cm)

Rear-Facing using 5-point harness
Child and child restraint are placed in the
back seat, facing the back of the vehicle.

Children up to 1 year of age must ride rear facing.

The American Academy of Pediatrics recommends that children remain rear facing until they are at least 2 years old.

In this child restraint, your child can remain rear facing up to 40 lb (18 kg) and up to 40 in. (101.6 cm).



22-65 lbs (10.1-29 kg)
and 29-49 in. (73.6-125 cm)
and at least 1 Year Old

Forward-Facing using 5-point harness
Child and child restraint are placed in the back
seat, facing the front of the vehicle.

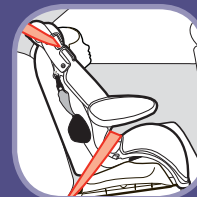

40-100 lbs (18.1-45.4 kg)
and 43-52 in. (110.1-132.1 cm)

Belt-positioning booster using vehicle lap/
shoulder belt combination

Child and child restraint are placed in the
back seat, facing the front of the vehicle.
5-point harness is removed.

The American Academy of Pediatrics recommends that children remain in a five-point harness until they outgrow their forward-facing harnessed child restraint.

This typically occurs around age 4, but some children outgrow them sooner and others not until later.

C-2 Preparing Child Restraint to Fit Your Child

You **MUST** make these adjustments with your child before you install the child restraint in the vehicle.

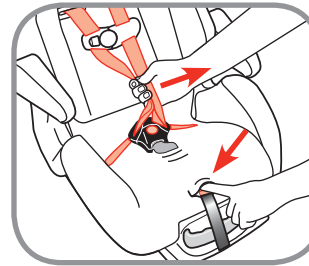

1. Loosen Harness

Push down on the harness release lever (under flap on the front of restraint) while pulling out on the harness.

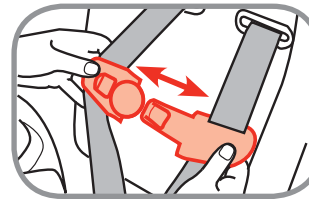

2. Release Chest Clip

Press on chest clip release button and pull apart.

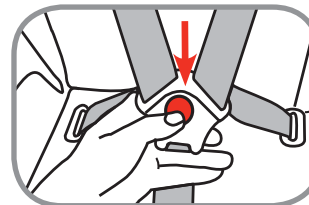

3. Unbuckle Harness

Press red button. Pull buckle tongues out. Place harness straps out of the way.



4. Place Child in Restraint

Place the child's bottom and back flat against the restraint. This will increase comfort and allow the harness straps to be properly tightened.

C. Basic Use

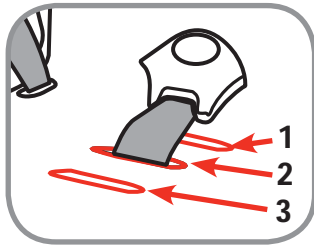

5. Check Buckle Position

Determine which of the available buckle positions will be comfortable and provide a snug fit for your child.

You MUST use the 1st or 2nd buckle strap slots when rear-facing. Any slot can be used for forward-facing.

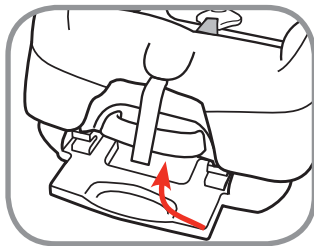

To Change Buckle Position

a. Fully recline the child restraint. Reach under the seat between base and shell.

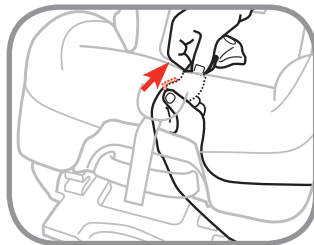

b. Locate buckle's metal retainer under the shell. Rotate metal retainer, then insert retainer up through the shell and pad.

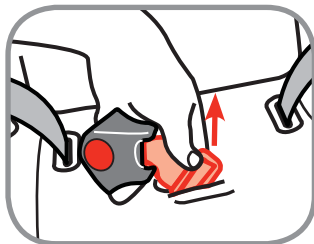

c. From the top, pull buckle free from shell and pad.

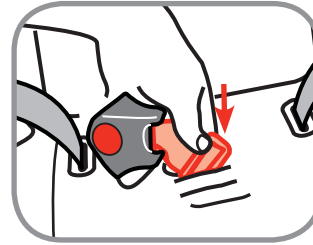

d. Reposition buckle location. Insert the buckle's metal retainer through the desired slot. Make sure buckle is facing forward.

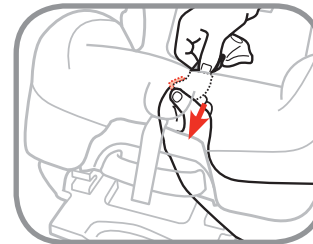

e. Reach under seat between base and shell. Pull buckle's metal retainer **completely through pad and shell.**

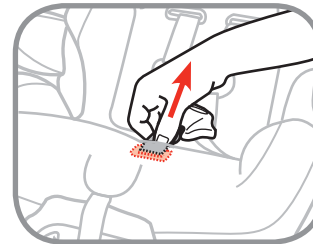

f. Pull up on buckle to make sure it is secured. **The buckle must not pull out.**

C. Basic Use

⚠ WARNING:

Failure to place buckle's metal retainer completely through pad and shell can result in serious injury or death.



6. Check Harness/Headrest Height

With child in the seat, check the location of the harness guide.

Follow the guidelines below to determine the correct harness/headrest height.

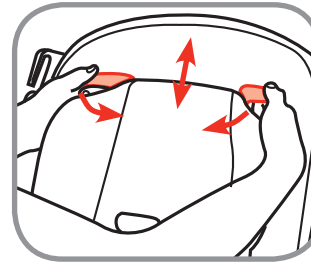

7. To Adjust Harness/Headrest Height

Loosen harness straps. Rotate headrest/harness height adjustment levers inward. Move headrest to the proper height and lock into place.



Rear-Facing Position

Harness strap **MUST** be at or slightly below shoulders.

If the harness strap is above the child's shoulders with the headrest in the lowest position, **do not** use this child restraint.



Forward-Facing Position

Harness strap **MUST** be at or slightly above shoulders.

If the harness strap is below the child's shoulders with the headrest in the highest position and the child weighs at least 40 lbs. (18.1 kg), you must convert the seat to a belt-positioning booster.

⚠ WARNING:

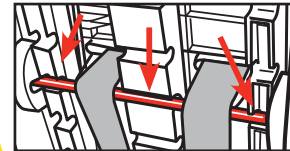

Make sure **metal bar is locked** into position. Failure to do this can result in serious injury or death.

⚠ WARNING:

Make sure that the harness height is correct for your child's size.



Do not use this child restraint rear facing unless the top of your child's head is at least 1 in. (2.5 cm) below the top of the child restraint's headrest.

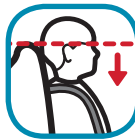

Do not use this child restraint forward facing if the tops of your child's ears are above the top of the child restraint's headrest.

Failure to follow these steps can result in serious injury or death.

C. Basic Use

C-3 Securing Child in Child Restraint



1. **Position Harness Straps Over the Child's Shoulders.**

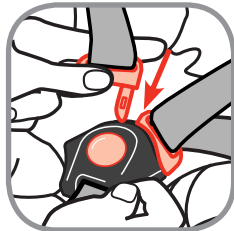

2. **Buckle Harness**

Push each buckle tongue into buckle until you hear a "click". Remember to always pull up on harness straps to make sure buckle is locked.

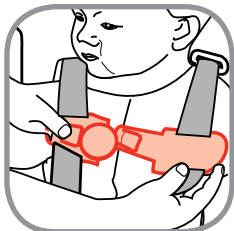

3. **Close Chest Clip**

Insert right half of chest clip into left half and snap together.

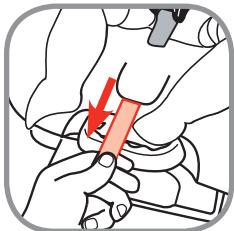

4. **Tighten Harness**

Pull on harness tightening strap to tighten harness snugly.

NOTE: A snug strap should not allow any slack. It lies in a relatively straight line without sagging. It does not press on the child's flesh or push the child's body into an unnatural position.

17



5. **Check Harness Tightness**

Try to pinch the harness at the shoulders. If you can pinch the harness strap, tighten more. If your fingers slip off, the harness is tight enough.



6. **Position Chest Clip**

The chest clip must be placed at mid-chest (even with armpits) and away from the child's neck.

For small infants, you may have to remove the harness covers.

⚠ WARNINGS: Failure to fasten and tighten the harness system correctly may allow the child to be ejected from the child restraint in a crash or sudden stop causing serious injury or death.

Do not mistake comfort for safety. Harness system must be snugly adjusted.



DO NOT put snowsuits or bulky garments on your child when placing them in the child restraint.

Bulky clothing can prevent the harness straps from being tightened properly.

18

C-4 Removing Child From Child Restraint

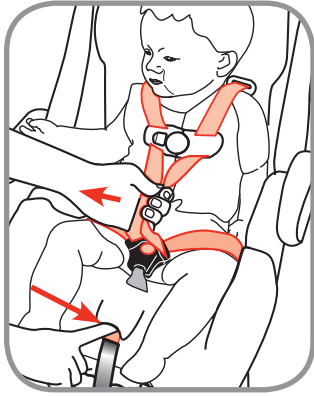

1. Loosen Harness

Press on harness release lever while pulling on harness straps above the the buckle to loosen.

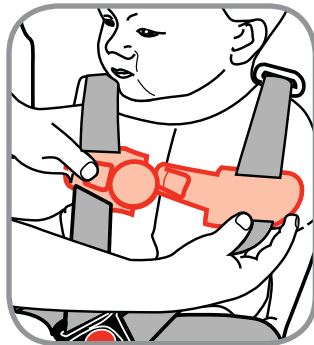

2. Release Chest Clip

Press on release button and pull apart.

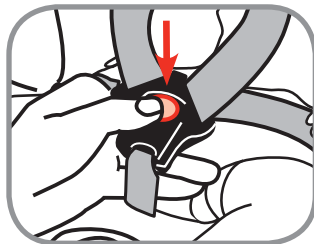

3. Unbuckle

Press red button on buckle to release the buckle tongues. Move harness away from child and remove child.

C-5 Accessories on Select Models

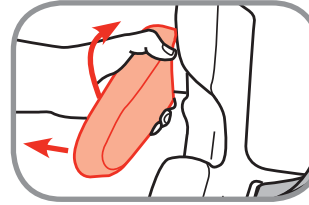

Rotating Armrests

Pull out arm, rotate and lock into place.

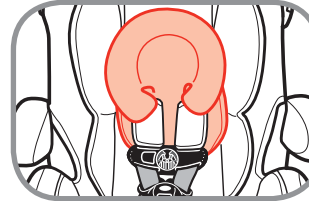

Infant Insert (on select models)

Insert must not cover the infant's face. Remove the insert for older babies and toddlers.

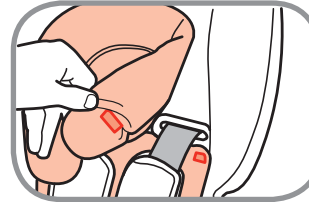

To remove the insert, undo the fastening strips and slide the insert out.

Reverse to replace insert.

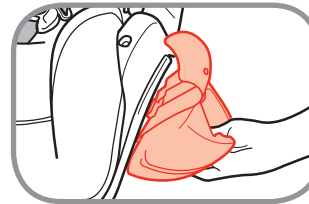

Install Cup Holder (on select models)

Pull pad off corner. Hook bottom of cup holder to edge of shell.

Rotate cup holder up until it snaps into the hole on the shell. Replace pad.

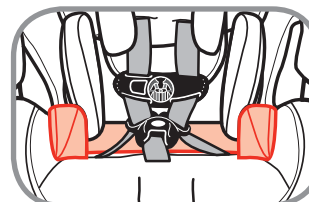

Lumbar Support (on select models)

To remove the lumbar support, loosen harness system and pull the lumbar support out from behind the harness system.

C-6 Reclining Child Restraint

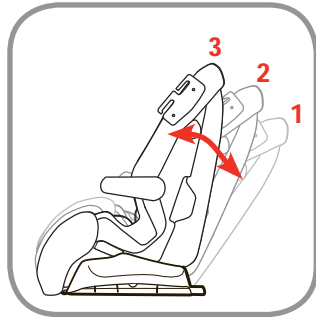

This child restraint has 3 positions:

Rear-Facing - Recline restraint so that the level lines on shoulder belt-positioning guide are level with ground.

Forward-Facing - 2 Semi-reclined or 3 upright.

NOTE: When forward-facing, the semi-reclined position is to be used only to install the child restraint flush against the back of vehicle seat back.

To Recline

Pull out on handle.

For upright position, pull out on handle and position the child restraint upright.

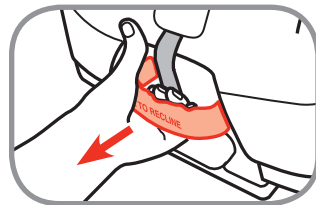

C-7 Removing Harness System

Harness system **MUST** be removed to use this child restraint as a Belt-Positioning Booster.

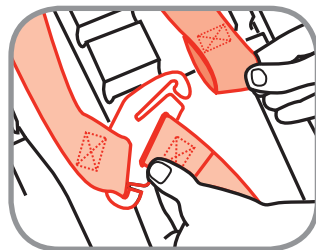

1. Remove Harness Straps from Splitter Plate

Fully loosen harness straps. Locate splitter plate on the back of the seat and unfasten the harness straps.

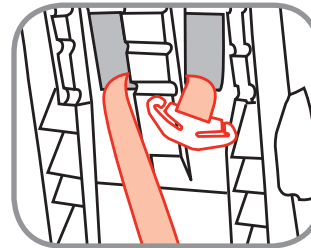

2. Store Splitter Plate

Raise headrest all the way up. Store splitter plate by pushing it through one opening and out the other.

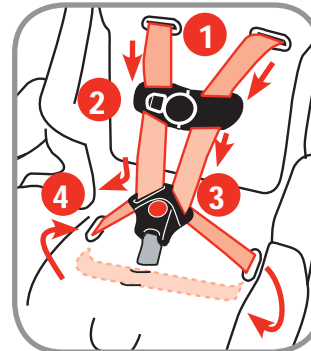

3. Remove Harness Straps

Pull harness through the slots from the front (1).

Unthread harness from the chest clip (2).

Unthread harness from the buckle tongues (3).

Pull harness out of shell (4).

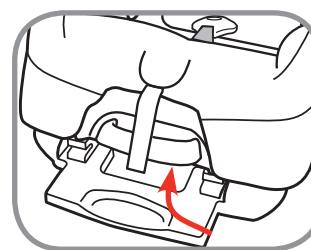

4. Locate Buckle's Metal Retainer

Fully recline the child restraint. Reach under the seat between base and shell.

C. Basic Use

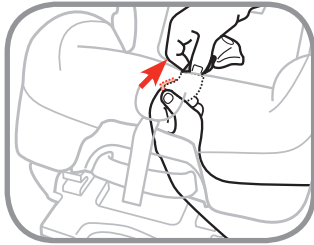

5. Insert Metal Retainer Through Shell and Pad

Locate buckle's metal retainer under the shell.

Rotate metal retainer, then insert retainer up through the shell and pad.

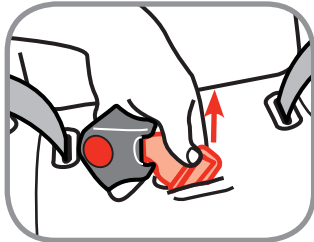

6. Remove Buckle from Child Restraint

From the top, pull buckle free from shell and pad.

C-8 Installing Harness System

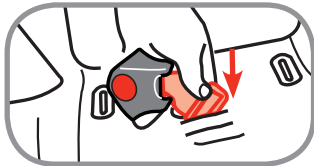

1. Install Buckle

Fit the buckle's metal retainer through the slot in the seat. Red button must face out.

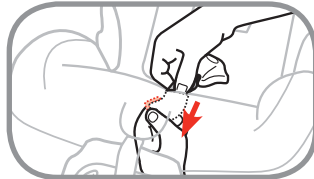

Pull buckle's metal retainer **completely through pad and shell** from bottom of seat.

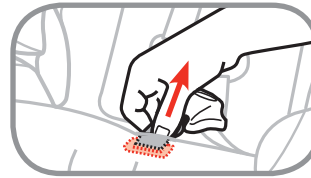

2. Check Buckle

Pull up on buckle to make sure it is secured. **The buckle must not pull out.**

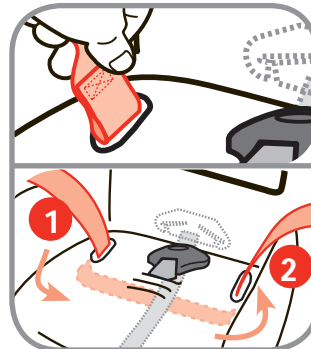

3. Thread Harness Strap

Thread the harness down through slot on left side of plastic shell (1) and up through slot on right side (2).

NOTE: Make sure sewn end of the harness strap loop faces the buckle before starting.

Take both ends of the harness and make them even in length.

NOTE: Make sure harness tightening strap is between the harness strap and shell as shown.

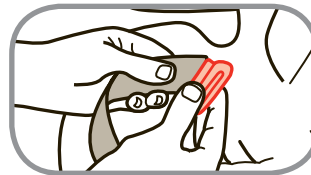
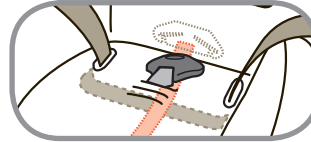

4. Thread Harness Guides on Harness Strap

If you have removed the harness guide, slide one harness guide on each harness strap end.

C. Basic Use

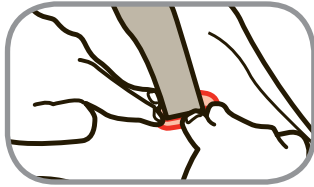

5. Secure Harness Guides
Press harness guides into the holes in the pad and shell.

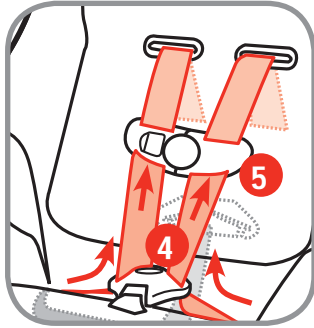

6. Thread harness strap through the back of the buckle tongue (4). Thread the chest clip front to back as shown (5). Do the same to the other harness end. **Do Not twist harness straps.**

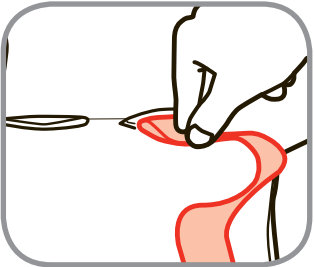

7. Push harness ends through slot in headrest. Repeat for the other harness strap.

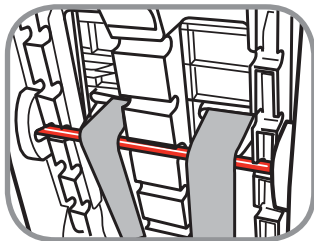

8. Thread Harness OVER Metal Bar

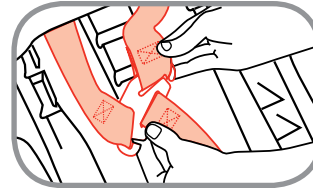

9. Attach Harness Straps to Splitter Plate
Fit loops on harness ends **completely** on the splitter plate.

⚠ WARNING:
Harness **MUST** be threaded over the metal bar.
Harness system must be reattached correctly.
Buckle's metal retainer must be completely through pad and shell.
Failure to follow these warnings can result in serious injury or death.

C. Basic Use

C-9 Removing Seat Pad for Cleaning

You must remove the harness system to remove the pad.

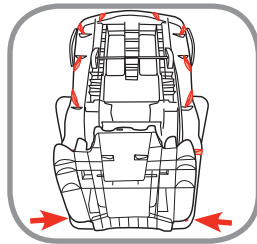

1. Remove the Elastic Straps

Release the elastic straps on the back and under side of the seat.

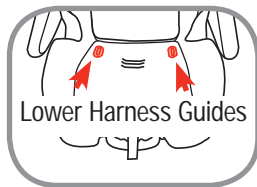

2. Remove Harness Guides

Remove both lower harness guides in bottom of seat.

From the back of the seat, locate the lower harness guides that are between the bottom of the seat and base. Remove both lower harness guides (A) in bottom of seat.

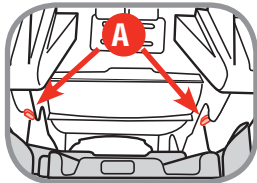

Push harness guide lip toward outside of shell with one hand while pulling harness guide from the front with the other.

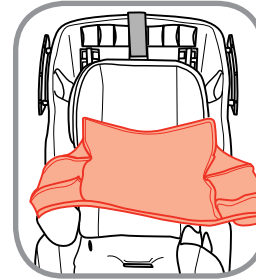

3. Remove Seat Pad

Adjust backrest to lowest position. Pull pad off the top of seat and around headrest. Slip off armrest and headrest pads.

Cleaning Seat Pad

If your seat pad has a machine washable tag:

Machine wash separately with cold water on a gentle cycle. Make sure infant insert is closed so fastening strips are not exposed. Tumble dry separately for 10-12 minutes on low heat. Remove immediately.

If your seat pad does not have a machine washable tag:

Hand wash pad with warm sudsy water, rinse clean and air dry.

Do not use bleach or use other harsh cleaners. Do not dry clean.

Cleaning Harness Strap

Spot clean the harness straps.

⚠ WARNING:

Do not use child restraint without the seat pad.

Replace seat pad by reversing order; put pad on headrest. Starting from bottom of child restraint, slip pad on shell; pull harness tightening strap through pad. Make sure pad is under headrest. Attach all of the elastic straps. Rethread harness (see section C-9).

D-1 Vehicle Seating Position



Never place a child rear facing in a seating position with an active frontal air bag.

Check the vehicle owner's manual for more information about air bag/child restraint use.



Use the child restraint only on vehicle seats that face forward.

Do not use on seats that face the sides or rear of the vehicle.



Use the center seating position if possible.

For vehicles without a back seat, refer to your vehicle owner's manual.

If you are not sure where to place the child restraint in your vehicle, consult your vehicle owner's manual, contact Dorel Juvenile Group Consumer Care Department (see page 58), or visit your local Child Passenger Inspection Station. Go to <http://www.safercar.gov/cpsApp/cps/index.htm> to find your closest station.



Children are safer when properly restrained in rear seating positions than in the front seating positions.

According to National Highway Traffic Safety Administration information, children in rear seating positions are statistically safer, whether you have air bags, advanced air bags, or no air bags at all.

To avoid your child being seriously burned, take the following precautions:

1. Park in the shade or where sun does not directly hit the child restraint.
2. Cover the child restraint with a sheet or blanket when not in use.
3. Check for hot seat and buckles before placing child in child restraint.

To help protect your vehicle seat's upholstery from damage, use a single layer towel underneath and behind child restraint.

D-2 Choosing Lower Anchor or Vehicle Belts

Your vehicle's features may be considerably different than those pictured here.

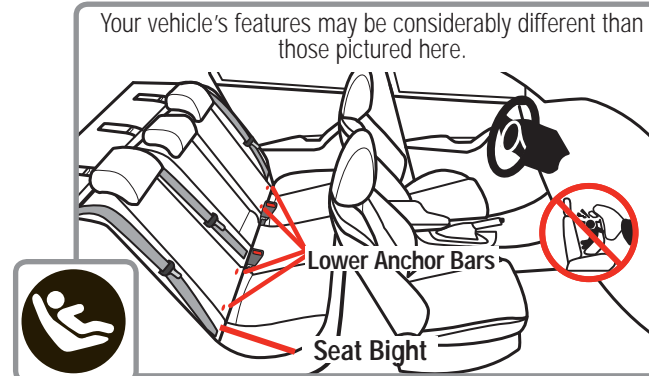

The LATCH System

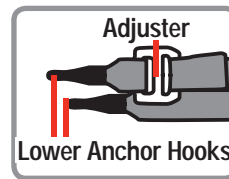

The lower anchors of LATCH (Lower Anchors and Tethers for Children) is a universal system for installing child restraints without using vehicle seat belts. The lower anchor system can ONLY be used in vehicles that have the lower anchor bars installed and designated

LATCH seating positions. Most vehicles manufactured after September 2002 are equipped with lower anchor bars.

Check your vehicle owner's manual to see which seating positions may be equipped with the LATCH system.

When installing this child restraint with vehicle belts or when using as a booster seat, the lower anchor hooks and belt MUST be properly stored.

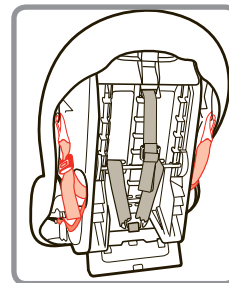

Storing Lower Anchor Belt

Thread lower anchor belt through forward-facing belt path. Then attach hooks to attachment as shown.

Gently pull free end of belt to remove slack.

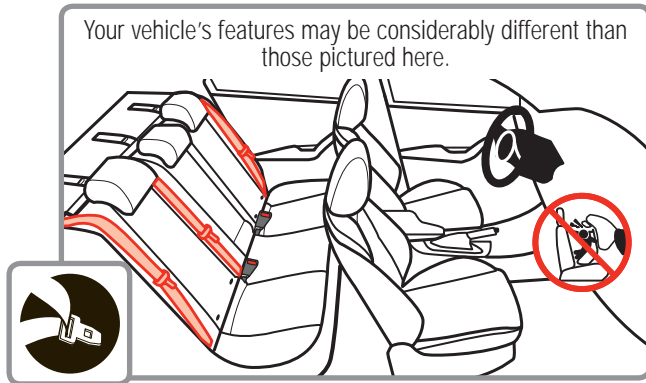

Vehicle Belts

If lower anchors are not an option or if your child weighs more than 40 lb (18 kg), you must use the vehicle seat belt system to install the child restraint.

There are some vehicle belts that will not work with a child restraint or will require special attention.

Check your vehicle owner's manual for specific instructions.

⚠ WARNINGS: When used correctly the lower anchor belt or vehicle belts are equally safe. Do not use both the lower anchor belt and vehicle belt at the same time.

D-3 Knowing Your Vehicle Belts

Not all vehicle belts and seating positions will work with child restraints. Please follow the following steps to understand how to lock a child restraint with a vehicle belt.

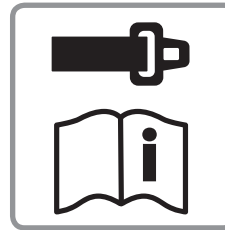

1. You MUST Review Your Vehicle Owner's Manual

Your vehicle owner's manual will let you know what vehicle belts and seating positions child restraints can be installed in.



2. Determine How the Child Restraint Will Be Locked Into Place

The vehicle belt MUST NOT loosen after tightening.

This means there needs to be a way to lock the vehicle belt.

The ways this can be done are:

- By using the seat belt's retractor; or
- By using the seat belt's latch plate.

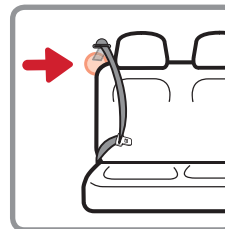

3. Check the Retractor

Retractors pull seat belts into stored positions and lock the belt to hold passengers in place.

A retractor is most likely how you will be locking a child restraint into place.

See the next page for some common types of vehicle belt retractors that will work with this child restraint.

Types of Retractors

Switchable Retractor
(most vehicles have this type)



This retractor can be switched to a locking mode.

You **MUST** have the retractor in the locking mode to use the seat belt with this child restraint.

Switching to locking mode: Slowly pull the shoulder belt all the way out, then let it go back in an inch or two.

As it goes back in, you will most likely hear a ratcheting sound.

Gently pull the belt to see if it has locked. You will not be able to pull any more belt out if the lock has engaged.

Automatic Locking Retractor



This retractor always locks.

It will automatically lock after slowly pulling the seat belt out at least halfway and letting the belt go back into the retractor an inch or two.

Emergency Locking Retractor

See Step 4, "Check the Latch Plates," on next page.

If the retractor does not lock, it is most likely an Emergency Locking Retractor. These retractors only lock during a sudden stop or collision.

You will need to determine if your seat belt's latch plate can lock the belt. See Step 4, "Check the Latch Plates," on next page.



4. Check the Latch Plates

Latch plates are the part of the seat belt that goes into the buckle.

Hold the lap belt with one hand and with your other hand grasp the tongue of the latch plate (the part that goes inside the buckle). Pull the latch plate straight out in line with the lap belt.

If the latch plate does not slide up and down the vehicle belt, it is a **locking latch plate**.

If the latch plate slides up and down the vehicle belt, it is a **sliding latch plate**.

Sliding latch plates easily slip between the lap and shoulder portions of the belt.

If you have an Emergency Locking Retractor with a Sliding Latch Plate, you **MUST** use a locking clip to install the child restraint. See section D-4.

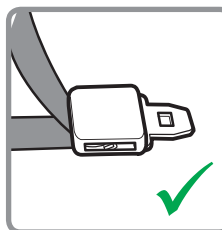

Locking Latch Plate

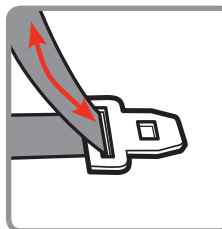

Emergency Locking Retractor with a Sliding Latch Plate

Never Use With This Child Restraint

Emergency Locking Retractor Lap Only Belt



Inflatable Seat Belts



D-4 Using the Locking Clip

You will rarely need to use a locking clip except in some older vehicles. Built in child restraint locking systems have been required in vehicles since 1996, and many vehicles had these features even earlier.

Check your vehicle owner's manual to learn how to use the systems in your vehicle. If you need a locking clip, return to the store where you purchased this child restraint to purchase a locking clip or call us at 1-800-544-1108 to order one.

Locking clips from any child restraint manufacturer are okay to use.

Remove the locking clip when the vehicle seat belt is not being used with the child restraint. A locking clip will not fix all types of seat belt problems. You **MUST** have a lap and shoulder belt to use a locking clip. **Do not use the locking clip when using this seat as a booster seat.** Refer to section D-3 to determine if your vehicle belts require a locking clip.

For Rear Facing installation, follow section E-4 Warnings and Steps 1-7 before starting locking clip installation.

For Forward Facing installation, follow section F-5 Warnings and Steps 1-7 before starting locking clip installation.

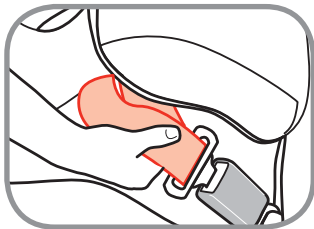

1. Locate Locking Clip Location

Grasp both vehicle belts together just behind the latch plate and unbuckle.

NOTE: If the latch plate ends up just at the belt path opening, grasp the belts on

the opposite side of the child restraint, as close to the latch plate as possible.

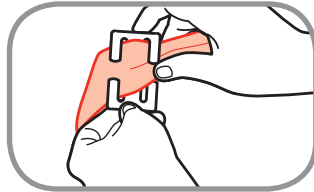

2. Attach Locking Clip

Thread both portions of the vehicle belt onto the locking clip, as close to the latch plate as possible.

35

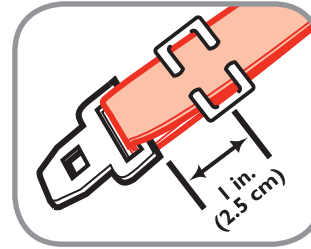

3. Position Locking Clip

Position locking clip about 1 in. (2.5 cm) from vehicle belt's latch plate.

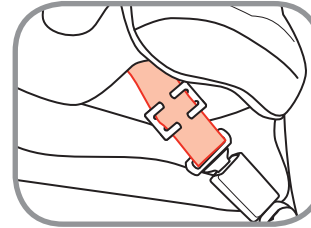

4. Rebuckle Vehicle Belt

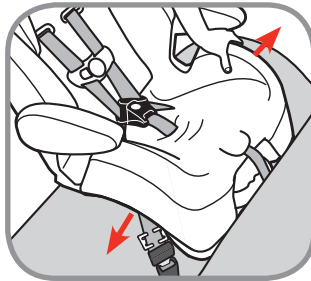

5. Check Belt Tightness

Grasp the child restraint at the belt path with one hand. Push and pull the child restraint from side to side, forward and back. The child restraint should not move more than 1 inch (2.5 cm).

NOTE: If it moves more than 1 inch (2.5 cm), redo the steps 5 through 9 again or try another seating location.

Recheck the recline angle to make sure it is reclined according to your child's weight. Repeat steps if not reclined correctly.

Remove the locking clip when the seat belt is not being used with a child restraint.

36

D-5 Installing on Aircraft



This restraint is certified for aircraft use when used with the internal harness.

This restraint is not certified for aircraft use when used as a booster

seat because aircraft seats do not have shoulder belts.

Use only on forward-facing aircraft seats.

Follow instructions for vehicle installation.

Contact the airline their specific policies.

E-1 Preparing to Install Rear-Facing

5-40 lbs (2.3-18 kg) and 19-40 in. (48-101.6 cm)
Rear-Facing using 5-point harness



Lower Anchor Belt



Lap/Shoulder Belt



Lap Belt

⚠ WARNING:



Never install a rear facing child restraint in the front seat of a vehicle equipped with an active frontal airbag.

This child restraint **MUST** always face the rear of the vehicle when the child is less than 1 year old.

The American Academy of Pediatrics recommends that children remain rear facing until they are at least 2 years old.

Please talk to your doctor about the best option for your child.



E-2 Preparing to Install Lower Anchor Belt Rear-Facing

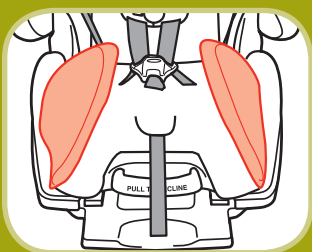

1. Pull Pad Off Corners of Child Restraint

Pull the seat pad off the front corners of shell.

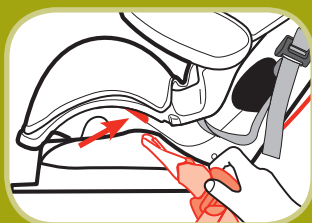

2. Routing Lower Anchor Belt

Insert the hook with adjuster through the rear-facing belt path.

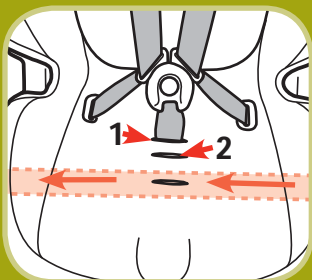

3. Pull Hook Across to Opposite Side

Reach under pad and pull the lower anchor hook across the shell. Lower anchor belt **MUST** be under pad and in front of buckle strap.

NOTE: You must use the 1st or 2nd buckle strap slots when rear-facing.

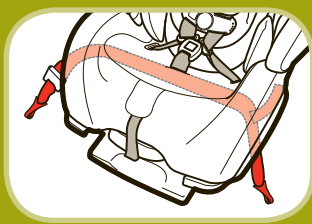

4. Replace Pad Over Corners

Make sure the belt is not twisted.



E-3 Install Rear-Facing with Lower Anchor Belt

⚠ WARNING:

Do not use the lower anchor belt along with the vehicle lap or lap/shoulder belt. Check lower anchor belt before each use. Use only if the belt can be tightened properly and securely.

Do not fasten multiple lower anchor hooks on the same lower anchor bar in the vehicle.

Store the tether hook when used rear facing. Attach the tether hook to storage attachment and gently tighten to remove slack.

Failure to follow these warnings can result in serious injury or death.



1. Store Top Anchorage Hook (Tether)

Attach the top anchorage hook (tether) to base as shown. Tighten tether to remove the slack.



2. Fully Recline and Place Child Restraint in the Back Seat Rear-Facing

For children between 5-22 lbs (2.3-10 kg), the bottom level to ground line **MUST** be level to the ground.



For children 22-40 lbs (10.1-18 kg) and can sit up unassisted, rotate the child restraint between the 2 level to ground lines. Start by making the bottom level to ground line level, then rotate seat up. DO NOT rotate past the top most upright level to ground line.



Adjust child restraint if needed. You may need to place a large rolled towel(s) or foam pool noodle(s) (A) under the front of the child restraint to help achieve the correct recline. Check often to be sure padding is still in place and the lower anchor belt is tight.

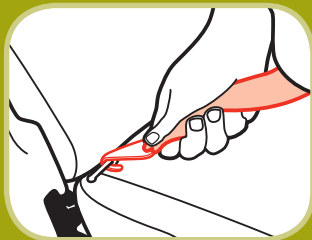

3. Hook Lower Anchor to Vehicle Lower Anchor

Fasten one lower anchor belt hook to the anchor in the vehicle seat located in the vehicle seat bight. Repeat for other side of child restraint.

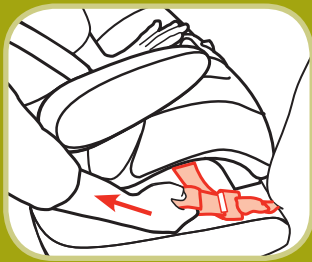

4. Tighten Lower Anchor Belt

Push down firmly on the child restraint and pull up on the free end of belt to tighten.

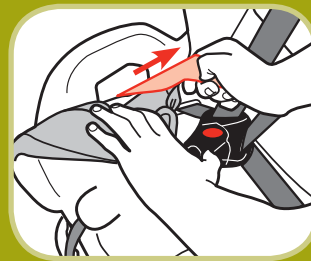

It maybe easier to tighten the belt through the belt path opening as shown.

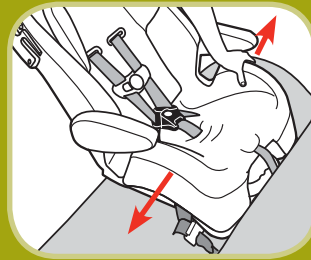

5. Check Belt Tightness

Grasp the child restraint at the belt path with one hand. Push and pull the child restraint from side to side, forward and back. The child restraint should not move more than 1 inch (2.5 cm).

NOTE: If it moves more than 1 inch (2.5 cm), try reinstalling the child restraint or try another seating location.



Secure your child in the child restraint. Recheck the recline angle to make sure it is reclined according to your child's weight. Repeat steps if not reclined correctly.



To Remove Lower Anchor Belt From Vehicle Anchor

Remove child from child restraint. Press down firmly on adjuster side of child restraint and press release button to release tension. Unhook lower anchor from bar by squeezing spring lever and twist hook.



E-4 Install Rear-Facing with Vehicle Belts

⚠ WARNING:

Do not use the lower anchor belt along with the vehicle lap or lap/shoulder belt. Secure lower anchor belt when using the vehicle belts.

Check the vehicle belt before each use. Use only if the belt is tightened properly and securely.

Attach the top anchorage hook (tether) to the base when used rear-facing.

Failure to follow these warnings can result in serious injury or death.



1. **Secure Lower Anchor Belts**

You **MUST** fasten the lower anchor belt connectors to the side of shell as shown when using the vehicle seat belts.

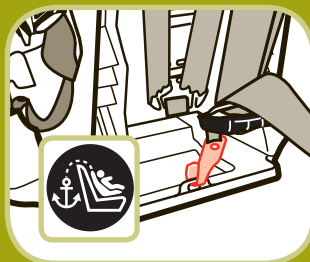

2. **Store Top Anchorage Hook (Tether)**

Attach the top anchorage hook (tether) to the base as shown. Tighten tether to remove the slack.



3. **Fully Recline and Place Child Restraint in the Back Seat Rear-Facing**

For children between 5-22 lbs (2.3-10 kg), the bottom level to ground line **MUST** be level to the ground.

For children 22-40 lbs (10.1-18 kg) and can sit up unassisted, rotate the child restraint between the 2 level to ground lines. Start by making the bottom level to ground line level, then rotate seat up. **DO NOT** rotate past the top most upright level to ground line. Adjust child restraint if needed.



You may need to place a large rolled towel(s) or foam pool noodle(s) (A) under the front of the child restraint to help achieve the correct recline. Check often to be sure padding is still in place and the vehicle belt is tight.

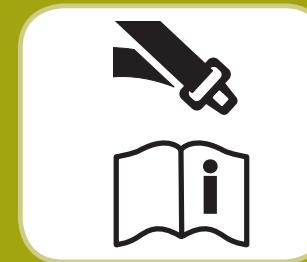

4. **Check if Your Vehicle Belts Will Work With This Child Restraint**

This is very important because not all vehicle belts will work with child restraints.

Review section D-3 and your vehicle owner's manual to determine what kind of vehicle belt you have and how to lock a child restraint in place.

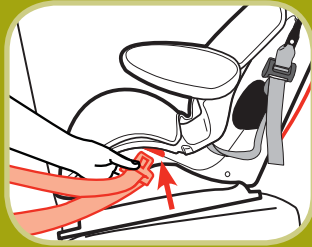

5. Thread Vehicle Belt

Thread the vehicle lap or lap/shoulder belt combination through the rear-facing belt path.

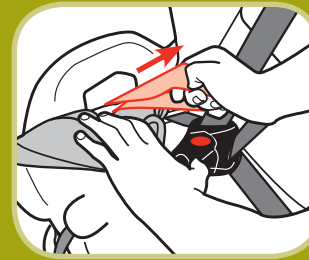

It maybe easier to tighten the belt through the belt path opening as shown.

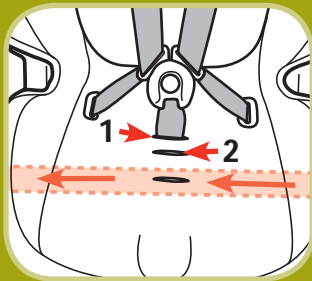

6. Pull Latch Plate Across to Opposite Side

Reach under pad and pull the vehicle belt across the shell. Vehicle belt **MUST** be under pad and in front of buckle strap.

Do not place vehicle belt over child's legs.

NOTE: You must use the 1st or 2nd buckle strap slots when rear-facing.

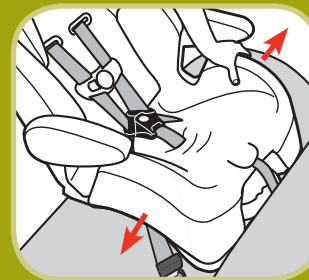

8. Check Belt Tightness

Grasp the child restraint at the belt path with one hand. Push and pull the child restraint from side to side, forward and back. The child restraint should not move more than 1 inch (2.5 cm).

NOTE: If it moves more than 1 inch (2.5 cm), try reinstalling the child restraint or try another seating location.

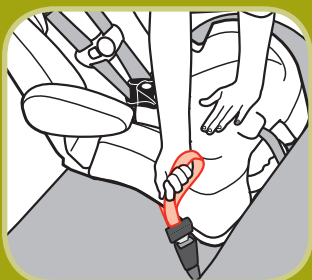

7. Tighten Vehicle Belt

Push down firmly on the child restraint and pull on the shoulder belt to tighten.



Secure your child in the child restraint. Recheck the recline angle to make sure it is reclined according to your child's weight. Repeat steps if not reclined correctly.

F-1 Preparing to Install Forward-Facing

22-65 lbs (10.1-29 kg) and 29-49 in. (73.6-125 cm) and at least 1 Year Old.

Forward-Facing using 5-point harness



Lower Anchor Belt with tether



Do not install by this method for a child weighing more than 40 lbs (18 kg).



Lap Belt with tether



up to 65 lbs. (29 kg)



Lap/Shoulder Belt with tether
up to 65 lbs. (29 kg)



⚠ WARNING:

In this child restraint your child **MUST** be at least 1 year old before they sit forward facing.

The American Academy of Pediatrics recommends that children remain rear facing until they are at least 2 years old and remain in a five-point harness until they outgrow their forward-facing harnessed child restraint.

Please talk to your doctor about the best option for your child.



F-2 Adjusting Top Anchorage Strap (Tether)

You **MUST** always attach, adjust, and secure the top anchorage (tether) strap when installing the child restraint forward facing with internal harness. Tethers improve the installation and stability of child restraints and reduce the risk of injury.

Attach the tether hook to the tether anchor designated by your vehicle manufacturer for that seating position. Check your vehicle owner's manual for more information.

If the seating position does not have a tether anchor, use a different seating position or see your dealer or a qualified mechanic and have one installed.

⚠ WARNING: Do not fasten multiple tether hooks on the same tether anchor in the vehicle.

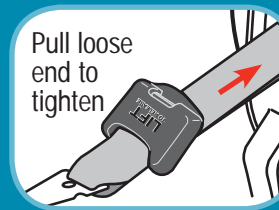

Pull loose end to tighten

Adjusting Tether Strap

To tighten: After the child restraint is locked into place with lower anchor belt or vehicle belt, push down on child restraint and gently pull on free end of tether.

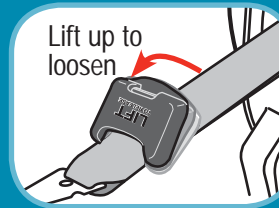

Lift up to loosen

To loosen: Lift up on tether lock adjuster and push it towards tether hook.



Storing Tether Strap

When installing rear facing, using as a booster, or when not in use, attach the tether hook to its storage attachment on the base as shown. Gently tighten to remove slack.



F-3 Preparing to Install Lower Anchor Belt Forward-Facing



WARNING:

Do not use the lower anchorage system (LATCH system) to attach this child restraint when restraining a child weighing more than 40 lbs (18 kg).

NOTE: Pull the lower anchor belt out of the rear-facing belt path if you have used this child restraint rear-facing.

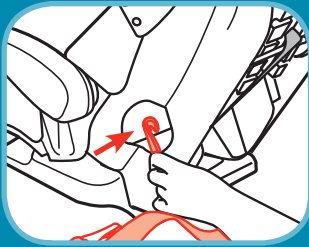

1. *Routing Lower Anchor Belt*

Insert the hook that has the adjuster closest to it, through the forward-facing belt path.

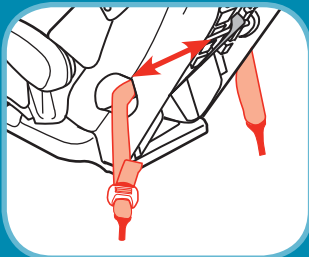

2. *Thread Lower Anchor Across*

Pull the lower anchor hook across the back and out the other side as shown. Do not twist the belt.



F-4 Install Forward-Facing With Lower Anchor Belt



NOTE: Review your vehicle's owner manual for lower anchor belt use.

WARNING:

Do not use the lower anchors of the child restraint anchorage system (LATCH system) to attach this child restraint when restraining a child weighing more than 40 lbs (18 kg).

The vehicle belt must be used for installation if your child weighs more than 40 lb (18 kg).

Do not use the lower anchor belt along with the vehicle lap or lap/shoulder belt.

Check the lower anchor belt before each use. Use only if the belt can be tightened properly and securely.

Do not fasten multiple lower anchor hooks on the same lower anchor bar in the vehicle.

Failure to follow these warnings can result in serious injury or death.



1. *Place Child Restraint in the Back Seat Forward-Facing*

Place child restraint **flush** against the vehicle seat back **forward-facing**.

Only use the recline position to install the child restraint flush against the back of the vehicle seat.

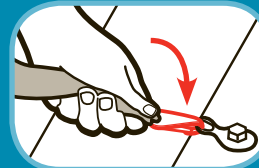

2. *Loosely Attach Tether Hook to Vehicle's Anchor*

Consult vehicle's owner manual for specific location.

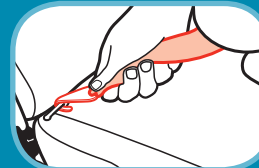

3. *Hook Lower Anchor to Vehicle Anchor*

Fasten one lower anchor belt hook to the anchor in the vehicle seat bight. Repeat for other side of child restraint.

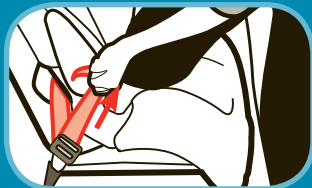

4. **Tighten Lower Anchor Belt**

Place hand or knee in the child restraint. Push down firmly while pulling up on the loop to tighten belt.

It may be easier to tighten the belt through the belt path opening as shown.

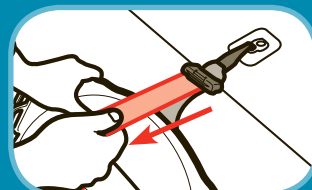
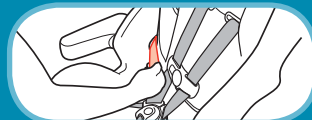

5. **Tighten Top Anchorage Strap**

Push firmly on the back of the seat and tighten top anchorage strap.

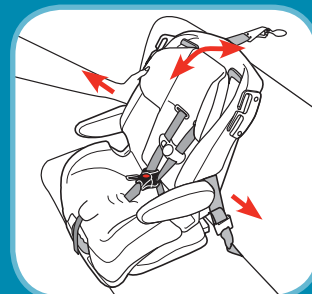

6. **Check Belt Tightness**

Grasp the child restraint at the belt path with one hand. Push and pull the child restraint from side to side, forward and back. The child restraint should not move more than 1 inch (2.5 cm).

NOTE: If it moves more than 1 inch (2.5 cm), try

reinstalling the child restraint or try another seating location.

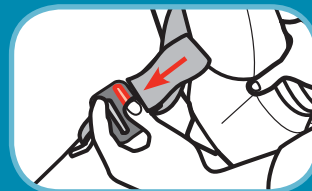

To Remove Lower Anchor Belt From Vehicle Anchor

Press down firmly on adjuster side of child restraint and press release button to release tension. Unhook lower anchor from bar by squeezing spring lever and twist hook.



F-5 Install Forward-Facing With Vehicle Belts

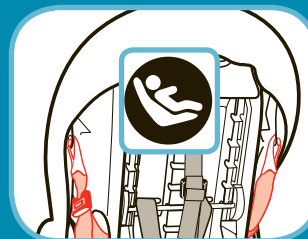

1. You **MUST** fasten the lower anchor belt hooks together behind seat when using the vehicle seat belts.

⚠ WARNING:

Do not use the lower anchor belt along with the vehicle belt. Secure lower anchor belt when using the vehicle belts.

Check the vehicle belt before each use. Use only if the belt is tightened properly and securely.

Failure to follow these warnings can result in serious injury or death.



2. **Place Child Restraint in Vehicle Forward-Facing**

Place child restraint **flush** against the back of the vehicle seat **forward-facing** in the back seat.

The recline position is to be used only to install the child restraint flush against the back of the vehicle seat.

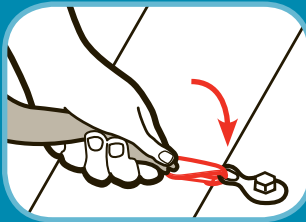

3. Loosely Attach Tether Hook to Vehicle's Anchor

Consult vehicle's owner manual for specific location.

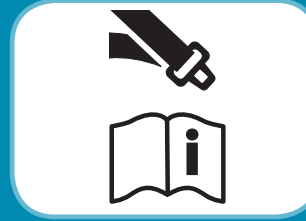

4. Check if Your Vehicle Belts Will Work With This Child Restraint

This is very important because not all vehicle belts will work with child restraints.

Review section D-3 and your vehicle owner's manual to determine what kind of vehicle belt you have and how to lock a child restraint in place.

5. Thread Vehicle Belt

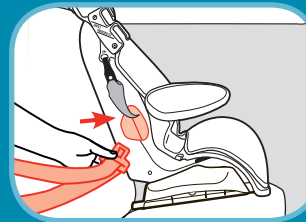

Thread the vehicle lap or lap/shoulder belt combination through the forward-facing belt slot and out the other side. Buckle vehicle belt.

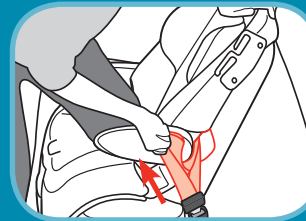

6. Tighten Vehicle Belt

Place hand or knee in the child restraint. Push down firmly on the child restraint and pull on the shoulder belt or lap belt adjuster to tighten.

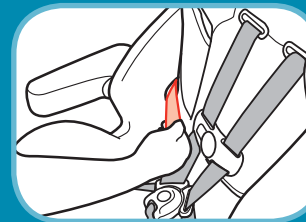

It maybe easier to tighten the belt through the belt path opening as shown.

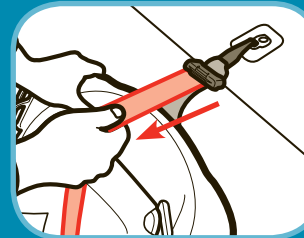

7. Tighten Top Anchorage Strap

Push firmly on the back of the seat and tighten top anchorage strap.

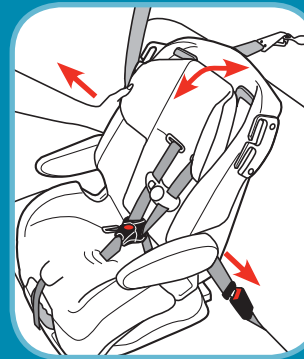

8. Check Belt Tightness

Grasp the child restraint at the belt path with one hand. Push and pull the child restraint from side to side, forward and back. The child restraint should not move more than 1 inch (2.5 cm).

NOTE: If it moves more than 1 inch (2.5 cm), try reinstalling the child restraint or try another seating location.

G-1 Preparing To Install Belt-Positioning Booster

40-100 lbs (18.1-45.4 kg) and 43-52 in. (110.1-132.1 cm)
Belt-positioning booster using only vehicle lap/
shoulder belt.



Lap/Shoulder Belt

You **MUST** remove the harness system (C-8) to use this seat as a belt-positioning booster. **DO NOT** remove the base.

⚠ WARNING:

Use only the vehicle's lap and shoulder belt system when restraining the child in this booster seat.

Do not use the lower anchor belts or top anchorage strap (tether) when using as a belt-positioning booster.

Secure both lower anchor belt and top anchorage strap.

Do not use the harness system when using as a belt-positioning booster.

Failure to follow these warnings can result in serious injury or death.

The American Academy of Pediatrics recommends that children remain in a five-point harness until they outgrow their forward-facing harnessed child restraint.

This typically occurs around age 4, but some children outgrow them sooner and others not until later.

Please talk to your doctor about the best option for your child.

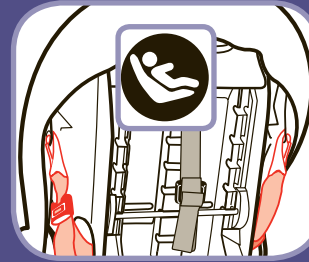

Store Lower Anchor Belts

Fasten the lower anchor belt hooks together behind seat.



Store Top Anchorage Strap (Tether)

Attach the top anchorage hook (tether) to the base as shown. Tighten tether to remove the slack.



G-2 Installing Using the Lap and Shoulder Belts

You **DO NOT** use a locking clip when using this seat as a belt-positioning booster.



1. Place Child Restraint Forward-Facing in Vehicle

Place child restraint in the back seat, **flush** against the back of the vehicle seat.



2. Place Child in Seat

Tops of the child's ears should never be above the top of the headrest.

Adjust headrest if needed, see section C-2.

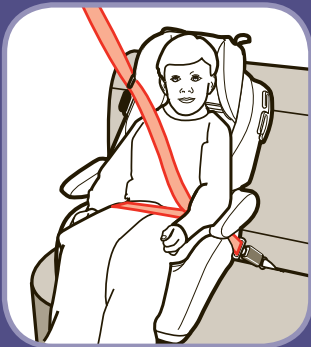

3. Buckle Lap and Shoulder Belt

Lap belt should cross the child's thighs. The shoulder belt should lay snugly across the center of the child's shoulders and across the chest (not on the face or neck). Both belts should be under the armrest.

Pull up on the shoulder belt to tighten.

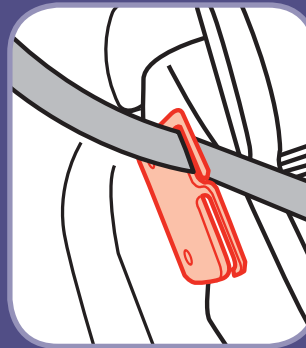

4. Position Shoulder Belt

To help position the shoulder belt, you may need to secure the shoulder belt through one of the notches in the shoulder belt-positioning guide.

Check periodically to ensure your child has not moved out of position and loosened the shoulder belt.

⚠ WARNING:

Use only the vehicle's lap and shoulder belt system when restraining the child in this booster seat.

Do Not Use only the lap belt when using this seat as a belt-positioning booster.

The shoulder belt must always be adjusted snugly across the child's chest.

NEVER place the shoulder belt under the child's arms.

Failure to follow these warnings can result in serious injury or death to your child.



Troubleshooting

- 1. Locate a Child Safety Seat Inspection Station for hands on training on how to use your child restraint:** Visit your local Child Passenger Inspection Station or go to <http://www.safercar.gov/cpsApp/cps/index.htm> to find your closest station.
- 2. If the child restraint buckle or harness release lever sticks or you cannot get the straps tight enough around child:** DO NOT LUBRICATE. Check around lever and retractor for dropped food, sticky spilled drinks, dirt, leaves, etc. Clean with warm water and/or remove object with tweezers. If you cannot get the harness to adjust and remain tight with the buckle securely locked, do not use the child restraint.
- 3. If your harness twists:** Straighten the harness each time you put your child in the child restraint to help prevent twisting. Lock the buckle and tighten harness so it will be ready for next use.

Replacement Parts Order Form

Complete the form below. Your model number with color code and manufacturer date code MUST be included on the form to ensure proper replacement parts. Your model number with color code and the date code can be found on a sticker on the side of child restraint. Payment in U.S. dollars must accompany your order. Choose parts needed from the list on the next page.

Return the form with payment to:

Dorel Juvenile Group, Inc.
Consumer Care Department
P.O. Box 2609
Columbus, IN 47202-2609

Please make money orders payable to Dorel Juvenile Group, Inc. Fill in the area below to charge to Visa or Mastercard. We do not accept personal checks or Discover Card. All outside of U.S. and Canada MUST use credit card.

Ship To (Please Print): _____

Name: _____

Address: _____

City: _____

State/Province: _____ Zip _____

Telephone: _____

Email Address: _____

We MUST have this information to process your order:

Model Number (5 digits & 3 letters): _____

Manufacture Date (mm/dd/yyyy): _____

Replacement Parts List

NOTE: If requested color is not available, similar color will be substituted. Prices are subject to change.

Part	Cost	Quantity	Total Cost
Buckle Strap/Buckle.....	\$4.99	X _____	= \$ _____
Harness Strap	\$2.00	X _____	= \$ _____
Pad Set	\$35.99	X _____	= \$ _____
Chest Clip.....	\$1.50	X _____	= \$ _____
Locking Clip	\$2.50	X _____	= \$ _____
Tether Kit	\$9.99	X _____	= \$ _____
Lower Anchor Kit.....	\$17.99	X _____	= \$ _____
Instructions	\$0.00	X _____	= \$ _____

Merchandise Total: \$ _____

Shipping and handling: \$ _____

Up to \$25.00.....	\$5.95	\$100.01 to \$150.00	\$10.95
\$25.01 to \$50.00	\$6.95	\$150.01 to \$200.00	\$11.95
\$50.01 to \$75.00	\$8.95	\$200.01 and up	\$13.95
\$75.01 to \$100.00	\$9.95	Outside Continental USA	\$10.00

Sales Tax: \$ _____
(Indiana, California, and Massachusetts residents add applicable sales tax.)

Grand Total: \$ _____

No shipping and handling on instructions for quantities under 6. Add \$.50 for each instruction over 6, then add applicable shipping and handling.

Fill Out For Credit Card
 Visa Mastercard

Card Exp. Date: _____

Cardholder's Name: _____

Card Number: _____

Signature: _____

Warranty

Dorel Juvenile Group, Inc. (DJG) warrants this product to the original retail purchaser as follows:

This product is warranted against defective materials or workmanship for one year from the date of original purchase. **An original receipt is required to validate your warranty.** DJG will, at its option, provide replacement parts or replace this product. DJG reserves the right to substitute if the part or model has been discontinued.

To make a claim under this warranty you may write to DJG, Consumer Care Department, P. O. Box 2609, Columbus, IN 47202-2609; or call 1-800-544-1108 from 8:00 a.m. to 6:00 p.m. EST Monday through Thursday and from 8:00 a.m. to 4:30 p.m. on Friday.

Proof of purchase is required and shipping charges are the responsibility of the consumer.

Warranty Limitations: This warranty does not include damages which arise from misuse or abuse of this product.

Limitation of Damages: The warranty and remedies as set forth are exclusive and in lieu of all others, oral or written, expressed or implied. In no event will DJG or the dealer selling this product be liable to you for any damages, including incidental or consequential damages, arising out of the use or inability to use this product.

Limitation of warranties and other warranty terms and state law rights:

Any implied warranties, including implied warranties of the merchantability and fitness for a particular purpose, shall be limited to the duration and terms of the express written warranty. Some states do not allow limitations as to how long an implied warranty lasts or the exclusion or limitation of incidental or consequential damages, so the above limitations may not apply to you.

This warranty gives you specific legal rights, and you may have other rights, which vary from state to state. Neither DJG nor the dealer selling this product authorized any person to create for it any other warranty, obligation, or liability in connection with this product.